

VICINITY MAP
N.T.S.

General Provisions:
These Development Standards form part of the Rezoning Plan associated with the Rezoning Petition filed by Trade Street Townhomes, LLC (the "Petitioner") to accommodate the development of a residential community on an approximate 3.21 acre site located at 4528 Wildwood Avenue, which is more particularly depicted on the Rezoning Plan (the "Site"). The Site is composed of three parcels identified as tax parcel numbers, 06310433, 06310445, and 06310432.

Development of the Site shall be governed by the Rezoning Plan, these Development Standards and the applicable provisions of the City of Charlotte Zoning Ordinance (the "Ordinance"). Unless the Rezoning Plan or these Development Standards establish more stringent standards, the regulations established under the Ordinance for the "R-8" Zoning District (as more specifically described and restricted below) shall govern all development taking place on the Site. The configurations, placements and sizes of the buildings, parking areas, tree save area, common open space, private roads and ancillary site elements depicted on the Rezoning Plan are schematic in nature and therefore are subject to refinements as part of the total design process. Since the project has not undergone the design development and construction phases, it is intended that this Rezoning Plan provide flexibility in allowing some alterations or modifications from the graphic representations of the Development/Site Elements.

Permitted Uses:
1) Uses allowed within the rezoning area shall be limited to residential uses allowable within the R-8 zoning district. Allowable residential uses shall be limited on site as described within the following descriptions and as generally illustrated within the Site plan.
a) A maximum of up to nine (9) buildings which may be any combination of single-family or duplex buildings but shall not exceed eighteen (18) total residential units, as generally depicted on the Site plan.
b) Allowable maximum height shall not exceed forty (40) feet as measured the Zoning Ordinance.

Transportation:
1) Vehicular and pedestrian access to the site from Wildwood Avenue may utilize the existing public right of way as generally depicted on the Rezoning Plan by development of a local residential medium street (L-02) standard as generally depicted on the Rezoning Plan, which shall be dedicated as a public street.
2) The placement and configuration of the vehicular access points shown on the Rezoning Plan is subject to any minor modifications required to accommodate final site and construction plans and designs.
3) Internal vehicular access to the site provided as generally depicted on the Site Plan.
4) Public sidewalk improvements shall include 6' landscape strip and 6' sidewalk along Wildwood Avenue and the internal street as generally depicted on the Site plan.
5) All transportation improvements within the public right of way shall be approved and constructed before the site's first building certificate of occupancy is issued.
6) The petitioner shall either dedicate fee simple conveyance of all rights of way and sidewalks to the City of Charlotte, or, provide an easement of all rights of way and sidewalks to the City of Charlotte prior to the Site's first building certificate of occupancy is issued.
7) A minimum of two (2) parking spaces per residential unit on site as generally depicted on the site plan, however, additional parking may be provided.

Architectural and Design Standards:
1) In addition to design provisions contained within the district regulations of the Zoning Ordinance, the development of the site will be governed by the following provisions and standards produced by the Petitioner and which will be binding on the development of the site. The proposed single-family attached building on site shall be designed to provide architectural elements that follow the design provisions noted below.
a) Maximum building height shall be a maximum of three (3) stories and forty (40) feet in height as measured by the applicable Ordinance standards.
b) To provide privacy, all residential entrances within 15 feet of the sidewalk shall be raised from the average sidewalk grade a minimum of 24 inches.
c) Pitched roofs, if provided, shall be symmetrically sloped no less than 5:12, except that roofs for porches and attached sheds shall be no less than 2:12, unless a flat roof architectural style is employed.
d) Usable porches and/or stoops shall form a predominant feature of the building design and be located on the front and/or side of the building. Usable front porches, when provided, shall not be at least 6 feet deep. Stoops and entry-level porches may be covered but shall not be enclosed.
e) The maximum blank wall expanse shall be limited to 15 feet on all building levels.
f) Garage doors visible from public or private streets shall minimize the visual impact by providing additional architectural treatments of either translucent windows or projecting elements over the garage door opening.
g) Walkways shall be provided to connect all residential entrances to sidewalks along public and private streets.

Streetscape and Landscaping:
1) The Petitioner shall provide 8 ft planting strip and 6 ft sidewalks as generally shown on the site plan.
2) Petitioner shall comply with the City of Charlotte Tree Ordinance.

Environmental Features:
1) The petitioner shall comply with the City of Charlotte Post Construction Ordinance and also provide peak control for the 50-year design storm event.
2) The location, size, and type of storm water management systems depicted on the Rezoning Plan are subject to review and approval as part of the full development plan submittal and are not implicitly approved with this rezoning. Adjustments may be necessary in order to accommodate actual storm water treatment requirements and natural site discharge points.

Lighting:
1) All attached and detached lighting will be full cutoff fixtures and downward directed, however, upward facing architectural and landscape accent lighting shall be permitted.

Amendments to Rezoning Plan:
1) Future amendments to the Technical Data Sheet or these Development Standards may be applied for by the then Owner or Owners of the parcel or parcels within the Site involved in accordance with the provisions of Chapter 6 of the Ordinance. Further alterations or modifications to the Rezoning Plan which, in the opinion of the Planning Director, substantially alter the character of the development or significantly alter the approved Technical Data Sheet or any of its conditions or which increase the intensity of development shall not be deemed to be minor and may only be made in accordance with the provisions of Subsections 6.207(1) or (2) of the Ordinance, as applicable.

Binding Effect of the Rezoning Documents and Definitions:
1) If this Site Plan Amendment is approved, all conditions applicable to development of the Site imposed under the Technical Data Sheet will, unless amended in the manner provided under the Ordinance, be binding upon and inure to the benefit of the Petitioner and the current and subsequent owners of the Site and their respective successors in interest and assigns.
2) Throughout these Development Standards, the terms, "Petitioner" and "owner" and "owners" shall be deemed to include the heirs, devisees, personal representatives, successors in interest or assigns.



SITE DEVELOPMENT TABLE:	
TAX MAP NUMBER: 06310433, 06310445, & 06310432	REQUIRED PARKING: 1.5 SPACES PER UNIT
EXISTING ZONING: R-5	SETBACKS & YARDS:
PROPOSED ZONING: R-8(CD)	FRONT: 17 FT
	SIDE: 5 FT.
	REAR: 20 FT.
	MIN. LOT SIZE: 6,500 SQ. FT
SITE AREA: 3.21 AC.	MAX HEIGHT OF BUILDING: 40 FT.
DEED INFORMATION: DB 31082 PG 314, DB 31448 PG 683, & DB 31082 PG 314	MIN. LOT WIDTH: 40 FT.
PROPOSED USE: DUPLEXES	WATER: CHARLOTTE WATER (PUBLIC)
PROPOSED UNITS: 18 (9 LOTS)	SEWER: CHARLOTTE WATER (PUBLIC)
DENSITY: 5.6 UNITS/ACRE	UTILITIES: ALL UTILITIES WILL BE UNDERGROUND AS REQUIRED BY CURRENT LAND DEVELOPMENT STANDARDS
GARBAGE COLLECTION: ROLL OUT CONTAINERS	POST CONSTRUCTION DISTRICT: CENTRAL CATAWBA
MIN. RECYCLING STATIONS REQUIRED: 1 - 144 SF STATION PER 80 UNITS	WATERSHED: IRWIN
RECYCLING STATIONS PROVIDED: 1 - 144 SF STATION	FLOOD DATA: ZONE 'X' PER COMMUNITY PANEL 371045-3500K, EFF. 9/2/2015
TREE SAVE REQUIRED: 10% (0.321 AC.)	DENSITY: HIGH
TREE SAVE PROVIDED: 10% (0.321 AC.)	
OPEN SPACE REQUIRED: 50% (1.605 AC.)	
OPEN SPACE PROVIDED: 50% (1.605 AC.)	

NOTE:
STORMWATER BMP SHALL BE DESIGNED IN ACCORDANCE WITH CHARLOTTE-MECKLENBURG BMP DESIGN MANUAL.

NOTE:
THIS SITE PLAN IS DEPICTIVE / CONCEPTUAL IN NATURE. MINOR ADJUSTMENTS TO THE LAYOUT MAY BE ALLOWED / NEEDED DURING SITE DESIGN AND DEVELOPMENT AFTER THE REZONING IS APPROVED. THIS SHALL BE ACCEPTABLE AS LONG AS THE INTENT OF THE REZONING IS UPHOLD.

NOTE:
UNIT SIZES SHOWN ARE APPROXIMATE. ACTUAL UNIT SIZES MAY VARY WITHIN BUILDING ENVELOPE.

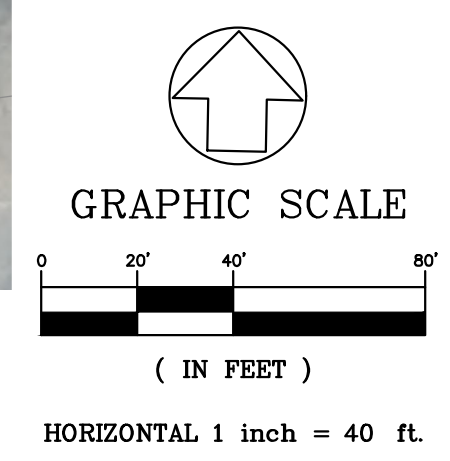

GATEWAY DESIGN GROUP, PLLC

15126 CASTLEBRIDGE LANE MATTHEWS, NC 28104
910-840-2861
NC FIRM # P-2147

PRELIMINARY NOT FOR CONSTRUCTION

WILDWOOD AVENUE TOWNHOMES
PROJECT ADDRESS: 4528 Wildwood Avenue Charlotte, NC 28208

NO.	BY	DATE	REVISION
1	JWB	11/4/22	REVISED PER CITY COMMENTS
2	JWB	2/23/22	REVISED PER CITY COMMENTS

PROJECT # 2021-017 DATE: 2/23/2022
DRAWN BY: JB CHECKED BY: JB

TITLE: **REZONING PLAN**

SHEET NO. **RZ-1.0**

C:\Users\jashw\Gateway Design Group\Projects\Projects\2021\017 - Wildwood Ave\CAD\References\X-input-wildwood.dwg_JOSH.W

© ALL RIGHTS ARE RESERVED. ANY POSSESSION, REPRODUCTION OR OTHER USE OF THIS DOCUMENT WITHOUT PROPER PERMISSION, IS EXPRESSLY PROHIBITED.