

### SITE DEVELOPMENT DATA

ACREAGE: ± 3.65 AC

TAX PARCELS: PORTION OF 183-141-13  
PORTION OF 183-141-17

EXISTING ZONING: MUDD-O

PROPOSED ZONING: MUDD-O SPA

EXISTING USES: Commercial

PROPOSED USES: Uses permitted by right and under prescribed conditions together with accessory uses, as allowed in the MUDD zoning district not otherwise limited in the Rezoning Plan.

MAX. DEVELOPMENT: Up to 250,000 square feet of office uses; and  
Up to 20,000 square feet of retail, EDEE or personal service or other commercial uses.

MAX. BLDG. HEIGHT: Up to 250 feet, per the Optional Provision in Section II

PARKING: As required by the Ordinance for the MUDD zoning district.

### LEGEND

- SETBACK
  - EXISTING OPEN SPACE
  - ADDITIONAL OPEN SPACE
  - DEVELOPMENT AREA
  - EXISTING ACCESS TO REMAIN
  - REZONING BOUNDARY\*\*
  - PARCEL BOUNDARY
  - EASEMENT
  - PRIMARY FACADE
- \*\*REZONING BOUNDARIES TO FOLLOW PARCEL LINES U.N.O.

### VICINITY MAP NTS

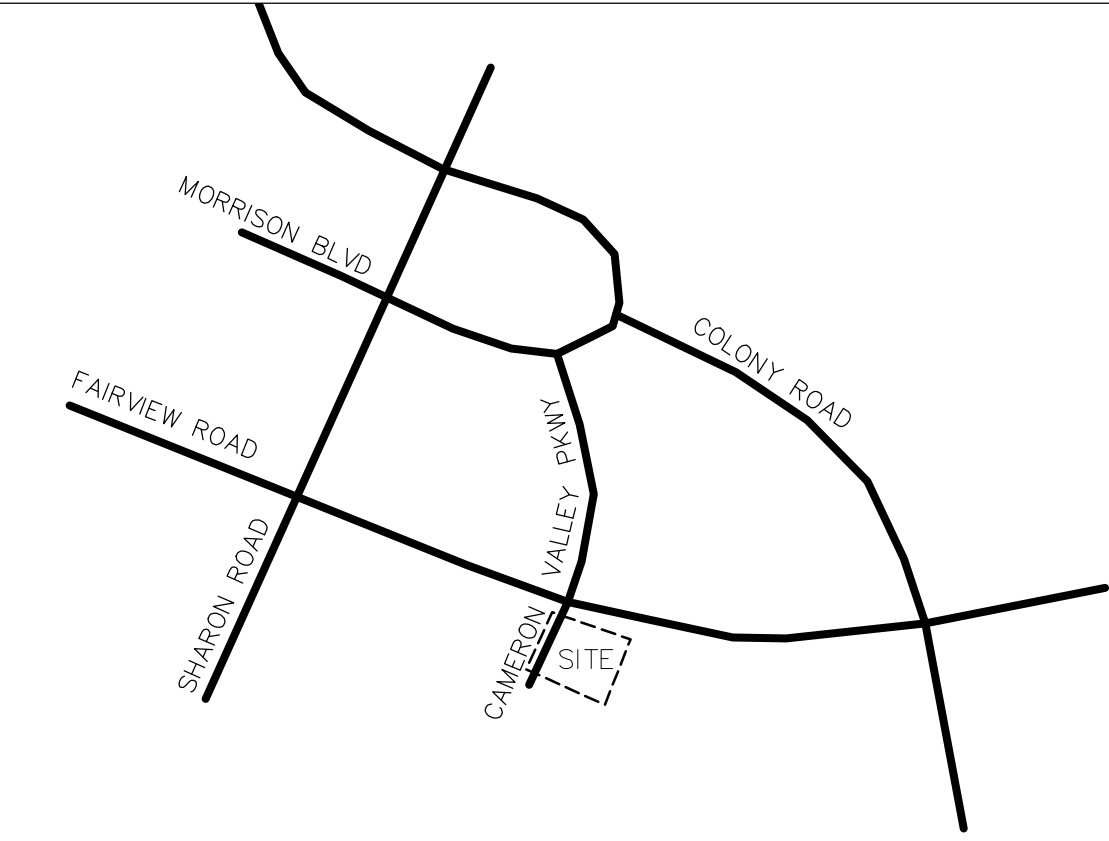

227 WEST TRADE STREET SUITE 700  
CHARLOTTE, NORTH CAROLINA 28202  
TEL. 704.333.6686 FAX 704.333.2926  
WWW.LS3P.COM

### PHILLIPS PLACE REZONING

DATE: 8 APRIL 2022  
PETITION NO: 2021-151

#### REVISIONS:

No.	Description	Date
1	REVISIONS PER STAFF REVIEW COMMENTS	11/15/21
2	REVISIONS PER STAFF REVIEW COMMENTS	12/13/21
3	REVISIONS PER STAFF REVIEW COMMENTS	01/17/21
4	REVISIONS PER STAFF REVIEW COMMENTS	02/14/21
5	REVISIONS PER STAFF REVIEW COMMENTS	03/24/22
7	REVISIONS PER STAFF REVIEW COMMENTS	04/11/22

### TECHNICAL DATA SHEET

# RZ-1A

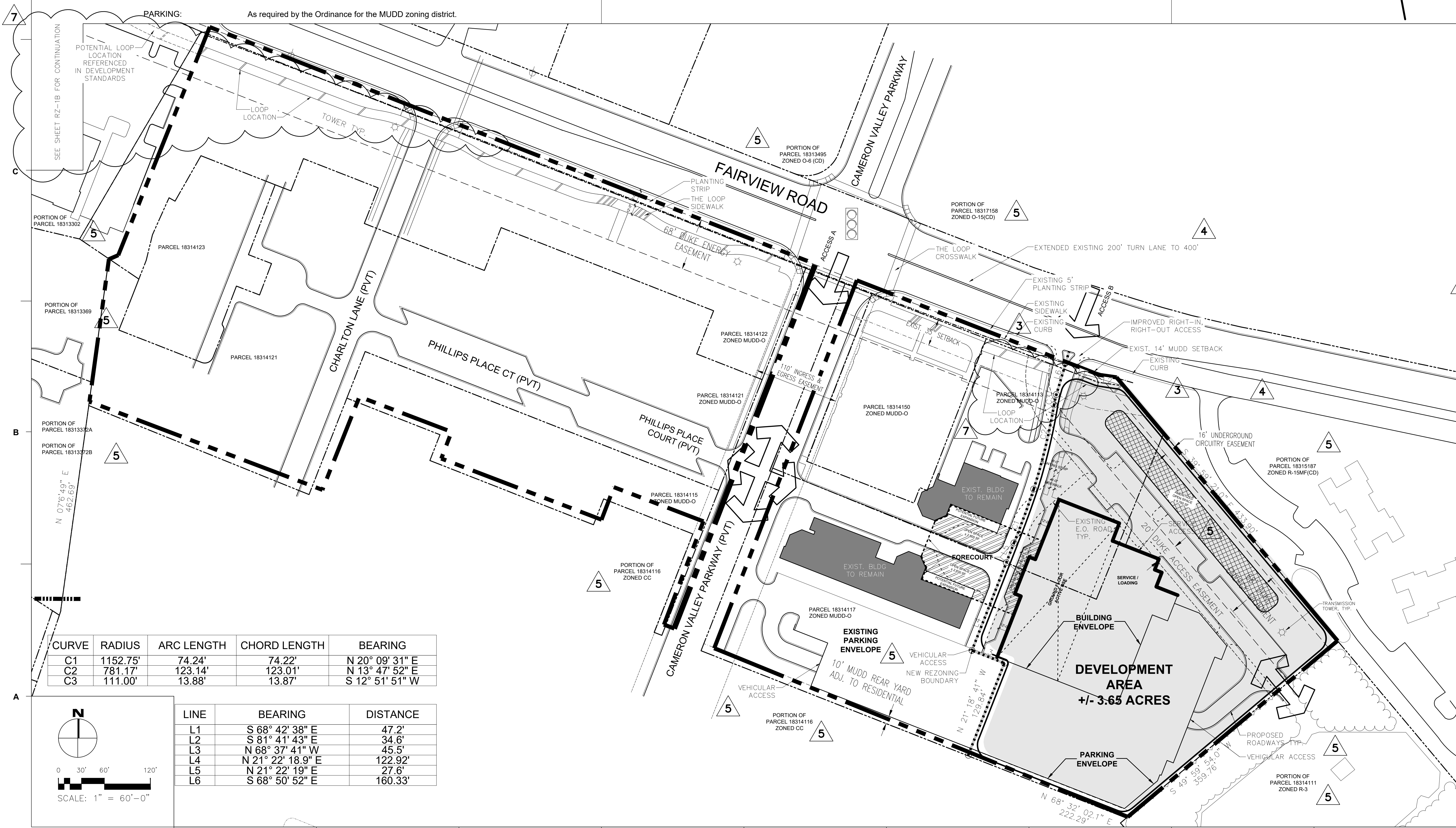

CURVE	RADIUS	ARC LENGTH	CHORD LENGTH	BEARING
C1	1152.75'	74.24'	74.22'	N 20° 09' 31" E
C2	781.17'	123.14'	123.01'	N 13° 47' 52" E
C3	111.00'	13.88'	13.87'	S 12° 51' 51" W

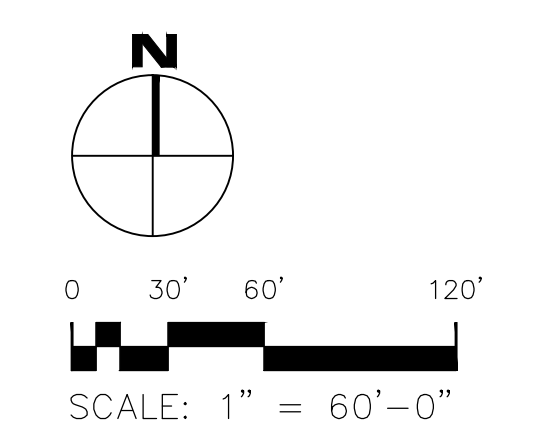

LINE	BEARING	DISTANCE
L1	S 68° 42' 38" E	47.2'
L2	S 81° 41' 43" E	34.6'
L3	N 68° 37' 41" W	45.5'
L4	N 21° 22' 18.9" E	122.92'
L5	N 21° 22' 19" E	27.6'
L6	S 68° 50' 52" E	160.33'

### SITE DEVELOPMENT DATA

ACREAGE: ± 3.65 AC

TAX PARCELS: PORTION OF 183-141-13  
PORTION OF 183-141-17

EXISTING ZONING: MUDD-O

PROPOSED ZONING: MUDD-O SPA

EXISTING USES: Commercial

PROPOSED USES: Uses permitted by right and under prescribed conditions together with accessory uses, as allowed in the MUDD zoning district not otherwise limited in the Rezoning Plan.

MAX. DEVELOPMENT: Up to 250,000 square feet of office uses; and  
Up to 20,000 square feet of retail, EDEE or personal service or other commercial uses.

MAX. BLDG. HEIGHT: Up to 250 feet, per the Optional Provision in Section II

PARKING: As required by the Ordinance for the MUDD zoning district.

### LEGEND

- SETBACK
  - ▨ EXISTING OPEN SPACE
  - ▩ ADDITIONAL OPEN SPACE
  - DEVELOPMENT AREA
  - EXISTING ACCESS TO REMAIN
  - REZONING BOUNDARY\*\*
  - PARCEL BOUNDARY
  - EASEMENT
  - PRIMARY FACADE
- \*\*REZONING BOUNDARIES TO FOLLOW PARCEL LINES U.N.O.

### VICINITY MAP NTS

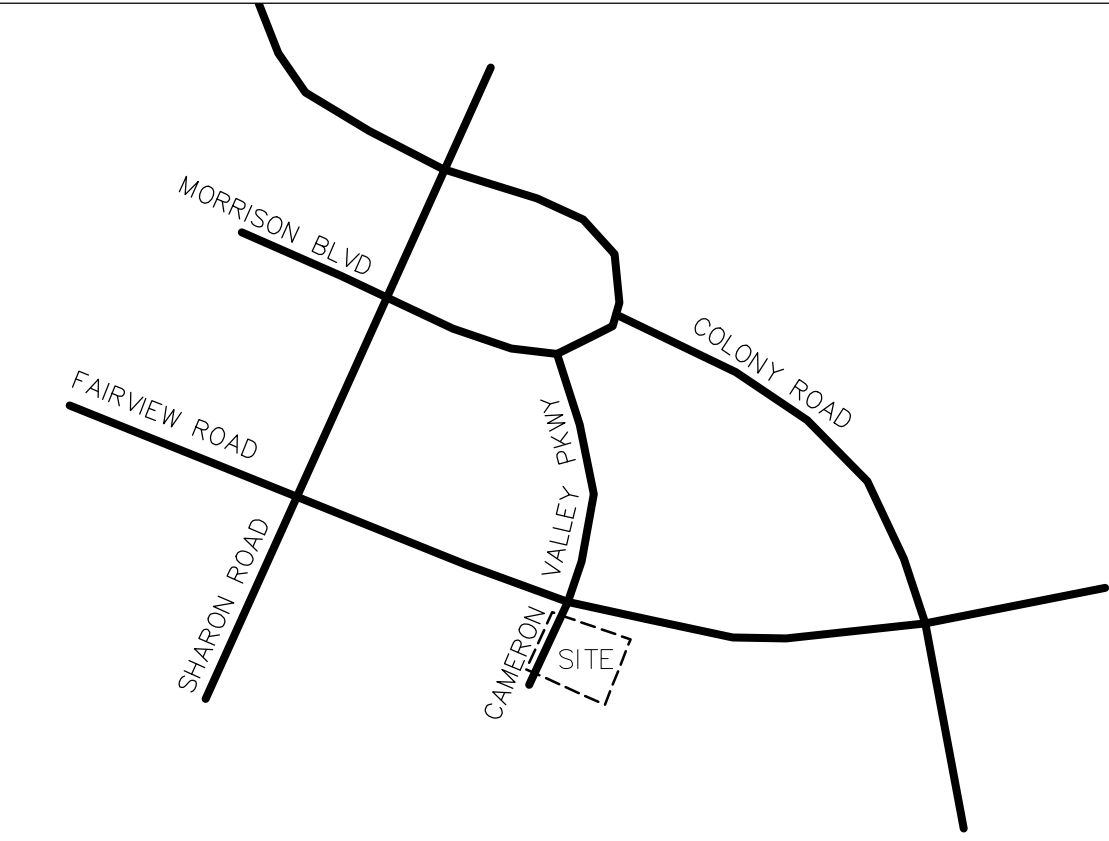

**LINCOLN HARRIS**  
4725 PIEDMONT ROW DRIVE  
SUITE 800  
CHARLOTTE, NC 28210  
(704) 714-7600  
www.lincolnharris.com

227 WEST TRADE STREET SUITE 700  
CHARLOTTE, NORTH CAROLINA 28202  
TEL. 704.333.6686 FAX 704.333.2926  
WWW.LS3P.COM

### PHILLIPS PLACE REZONING

DATE: 8 APRIL 2022  
PETITION NO: 2021-151

REVISIONS:

No.	Description	Date
1	REVISIONS PER STAFF REVIEW COMMENTS	11/15/21
2	REVISIONS PER STAFF REVIEW COMMENTS	12/13/21
3	REVISIONS PER STAFF REVIEW COMMENTS	01/17/22
4	REVISIONS PER STAFF REVIEW COMMENTS	02/14/22
5	REVISIONS PER STAFF REVIEW COMMENTS	03/24/22
7	REVISIONS PER STAFF REVIEW COMMENTS	04/11/22

TECHNICAL DATA SHEET

**RZ-1B**

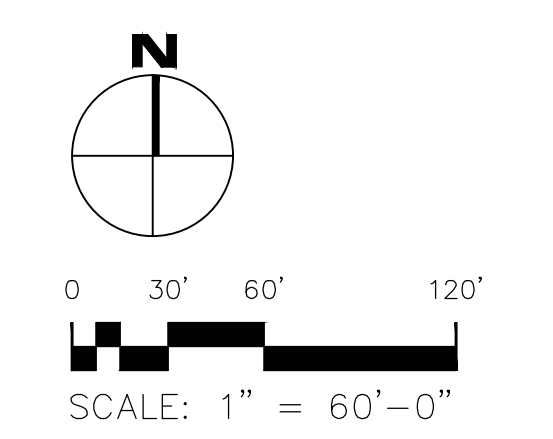
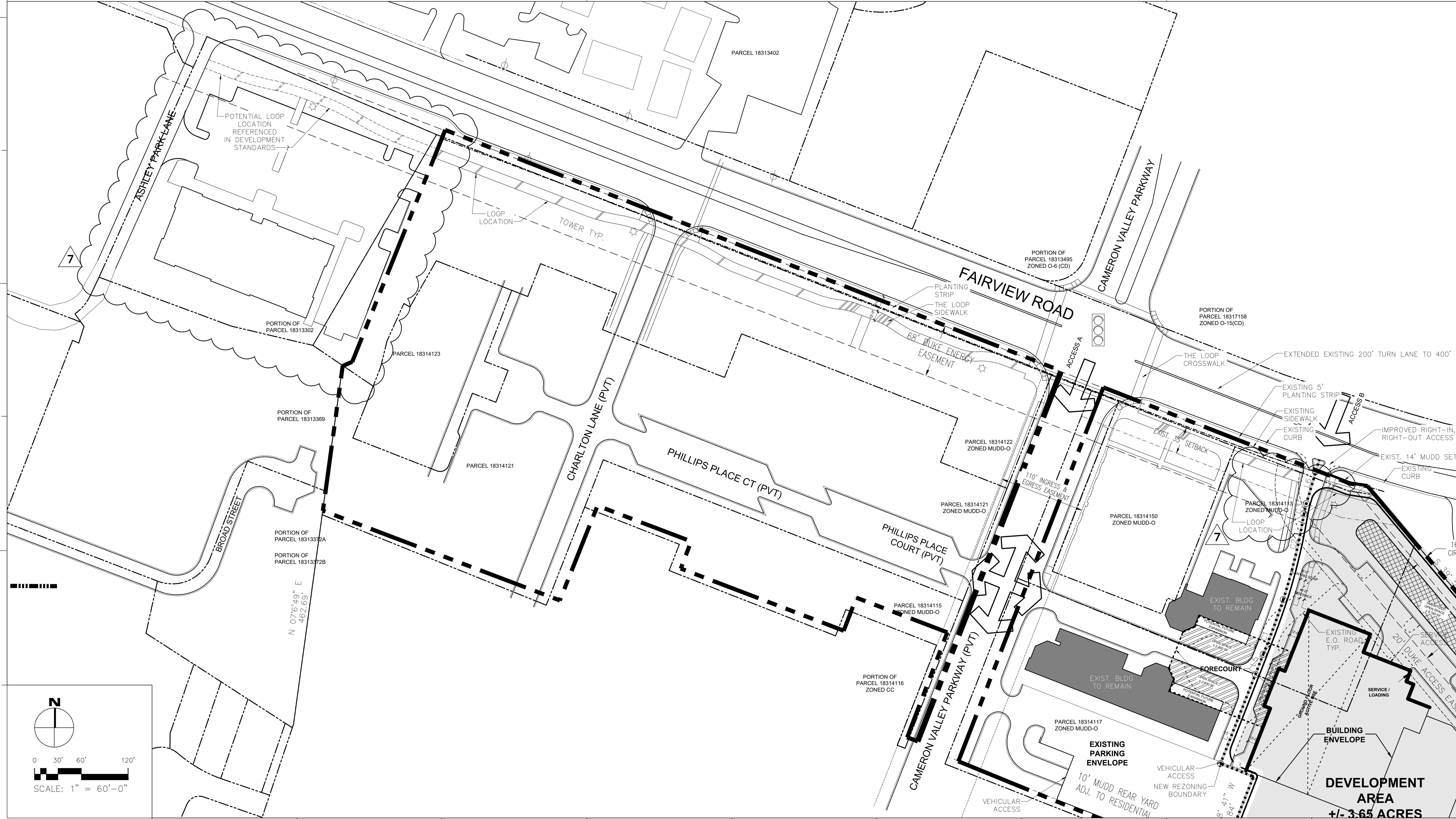

1 2 3 4 5

DEVELOPMENT AREA  
±/- 3.65 ACRES

**Site Development Data:**

- Acreage: ± 3.65
- Tax Parcels: Portions of parcels 183-141-13 and 183-141-17
- Existing Zoning: MUDD-O
- Proposed Zoning: MUDD-O SPA
- Existing Uses: Commercial
- Proposed Uses: Uses permitted by right and under prescribed conditions together with accessory uses, as allowed in the MUDD zoning district not otherwise limited in the Rezoning Plan.
- Maximum Development:
  - Up to 250,000 square feet of office uses; and
  - Up to 20,000 square feet of retail, EDEE or personal service or other commercial uses.
- Maximum Building Height: 250 feet, per the Optional Provision in Section II
- Parking: As required by the Ordinance for the MUDD zoning district.

**I. General Provisions:**

- Site Description.** These Development Standards and the Technical Data Sheet form the rezoning plan (hereafter collectively referred to as the "Rezoning Plan") associated with the Rezoning Petition filed by Lincoln Harris ("Petitioner") to accommodate development of a mixed-use building on an approximately 3.65-acre site located at the eastern terminus of Phillips Place Court, more particularly described as portions of Mecklenburg County Tax Parcel Numbers 183-141-13 and 183-141-17 (the "Site").
- Intent.** This Rezoning is intended accommodate development on the Site of a pedestrian-focused mixture of MUDD-permitted uses including but not limited to office, retail and other commercial uses integrated in the Phillips Place development.
- Zoning Districts/Ordinance.** Unless otherwise requested in the Optional Provisions, below, development of the Site will be governed by the Rezoning Plan as well as the applicable provisions of the City of Charlotte Zoning Ordinance (the "Ordinance").

**II. Optional Provisions**

The Petitioner requests the ability to exceed the height provisions in Section 9.8505(5) for a total of 250 feet of building height within the building envelope, measured from Phillips Place Court at front of building. For the sake of clarity, this height request does not apply to the proposed parking deck area outside of the building envelope.

**III. Permitted Uses**

Subject to the Maximum Development provisions set forth under Section IV below, the Site may be devoted to any non-residential uses permitted by right or under prescribed conditions in the MUDD Zoning District, together with any incidental or accessory uses associated therewith.

**IV. Maximum Development and Restrictions**

- Subject to the restrictions, limitations, and conversion rights listed below, the principal buildings constructed may be developed with up to: (i) 250,000 square feet of gross floor area of office uses (which, for the sake of clarity, shall also include club uses) and (ii) 20,000 square feet of retail, personal service, EDEE, and other non-residential uses permitted by right and under prescribed conditions in the MUDD zoning district, along with any accessory uses allowed in the MUDD zoning district (collectively, the "Building").
- Prohibited Uses:** Car washes (except for residential car wash stations); Automobile Service Stations; EDEEs with accessory drive-through service windows.
- Conversion Rights:**
  - Unused office uses may be converted to specialty retail at an equal rate of one (1) square foot to one (1) square foot, however the total amount of retail shall not exceed 40,000 square feet.
  - Unused office space may be converted to lodging uses at a rate of 500 square feet to 1 room so converted.

**V. Transportation**

- Vehicular access will be as generally depicted on the Rezoning Plan. The placements and configurations of the vehicular access points shown on the Rezoning Plan are subject to any minor modifications required to accommodate final site and construction plans and designs and to any adjustments required by CDOT for approval.
- The Petitioner shall incorporate the following transportation improvements as outlined in the Traffic Impact Study (TIS):
  - Extend the existing westbound left turn lane on Fairview Road from two hundred (200) feet to four hundred (400) feet;
  - Construct an additional southbound left turn lane on Colony Road with 250 feet of storage or provide an alternative transportation improvement of equal or lesser value, to be coordinated during permitting pending approval by CDOT; and
  - Extend the existing southbound left turn lane on Colony Road from 250 feet to 350 feet of storage.
- Petitioner shall construct a bus shelter pad and waiting pad per Land Development Standard 60.03A along Fairview Road. The final location of the pads shall be coordinated with CATS through the permitting process.
- Petitioner shall provide an internal sidewalk and planting strip where not already provided.
- Petitioner shall extend the Loop as generally depicted on the Rezoning Plan, in coordination with Planning Staff and CDOT.
  - In the areas shown as "Potential Loop Location," the Petitioner shall work with the adjacent property owner to provide the Loop extension toward Sharon Road to the west (across the property frontage of parcel 183-133-02, the "Allen Tate" building). Should Petitioner be unable to reasonably obtain appropriate approval, agreement and/or easements from the adjacent property owner (parcel 183-133-02, currently owned by Allen Tate at Phillips Place LLC), Petitioner shall invest an additional \$100,000 to the City of Charlotte for other Loop segments. Such contribution will be made after the Petitioner has made good faith efforts to obtain the appropriate easements and approvals from the adjacent property owner and at such time the Building is being constructed. It is expected that the Loop segments to benefit from this contribution will be in the SouthPark area and the contribution will be expended within thirty-six (36) months of receipt by the City of Charlotte.
    - This improvement shall serve as a contribution in lieu of the proposed bicycle and pedestrian connection to Broad Street contained in Rezoning Petition 2017-110, as administratively amended.
  - Petitioner shall complete the Loop installation as shown within twelve (12) months after receipt of the proposed office building permit. However, in the event of delays outside of the Petitioner's control (e.g., recognizing the potential for delays due to the responsibility of utility companies who are required to move utilities prior to Loop construction), Petitioner shall coordinate with CDOT and Planning Staff to demonstrate expeditious work is being planned to complete the Loop installation as soon as reasonably possible.
- (As related to the Loop commitment) Petitioner shall provide the following intersection improvements at Cameron Valley Drive and Fairview Road:
  - Add two direction, accessible ramps at the sidewalk at each of the four corners of the intersection; and
  - Add crosswalks using inlaid crosswalk/street print or colored thermos ideas for branding logos for the South Park area (the "loops"), at each of the four sides of the intersection. Patterns and design detail shall be coordinated with general services per project PMES201632

- Where necessary, the Petitioner shall dedicate and convey in fee simple all rights-of-way to the City of Charlotte before the Site's first building certificate of occupancy is issued.
- Unless otherwise stated herein, all transportation improvements shall be approved and constructed prior to the issuance of the Site's first building certificate of occupancy.

**VI. Design Guidelines:**

**a. General Design Guidelines.**

- The principal buildings constructed on the Site may use a variety of building materials. The building materials used for buildings will be a combination of any of the following: glass, brick, metal, stone, simulated stone, pre-cast stone, architectural precast concrete, synthetic stone, stucco/E.I.F.S., cementitious siding (such as hardi-plank), or wood/composite wood. Vinyl, as a building material, will only be allowed on windows, soffits and trim features.
- If structured parking is developed, exposed multi-level parking decks shall provide screening so that the view of interior lighting and cars is obscured from required public or private streets through the use of decorative louvers, architectural panels, metal and/or precast concrete barrier walls, including screening of vehicles from adjacent properties with a minimum 3.5-foot screening wall or other comparable screening measures.
- Meter banks shall be located outside of the setback.
- All dumpster enclosure areas shall be internal to the building/parking deck or screened from network required public or private streets with materials complimentary to the principal structure.
- Building height above sixty-five (65) feet shall include a minimum setback of ten (10) feet from the building façade line. Such setback shall occur above the ground story and no higher than the 5<sup>th</sup> story.
- Structured parking facilities shall not exceed sixty-five (65) feet in height, measured per the Ordinance.
- Building articulation:
  - At least 70% of the total ground floor height along primary facades shall meet the following ground floor height requirement: The floor-to-floor ground floor height along primary facades shall be a minimum of sixteen (16) feet.
  - A maximum of twenty (20) feet of blank wall area (horizontal or vertical) shall be provided along the primary building façade(s).
  - A maximum distance of seventy-five (75) feet shall be permitted between prominent entrances along the primary building façade(s).
  - The vertical distance between the building entry and sidewalk: 50% of the required prominent entrances along the sidewalk/building exterior shall meet grade.
  - Ground floor transparency area (measured 3' to 10' from finished grade): A minimum of 60% of the primary building façade(s).
  - Upper floor transparency (% wall area of story): A minimum of 40% for primary building façade(s).

**VI Loop, Open Space and Amenity Areas**

- The Petitioner will install the proposed Loop pedestrian and streetscape improvements, including a minimum twelve (12) foot multi-use trail, ten (10) foot amenity zone, and variable buffer, in the location and as generally depicted on the Rezoning Plan.
- The Petitioner will provide a "forecourt" a minimum 7,000 square feet of improved urban open space areas at the main entrance to the building, as generally depicted on the Rezoning Plan, to include specialty pavers and a minimum of two (2) of the following amenities: seating area, fountain, public art, picnic tables, benches, enhanced landscaping pergolas and/or trellis areas.
- The Petitioner will provide a minimum 9,000 square feet of amenitized urban open space area, as generally depicted on the Rezoning Plan, to include a minimum of two (2) of the following amenities: seating area, public art, picnic tables, benches, dog facilities, fitness amenities, and/or enhanced landscaping.

**VIJ. Environmental Features**

- The Petitioner shall comply with the Post Construction Stormwater Ordinance.
- The Petitioner shall comply with the Tree Ordinance.

**IX. Signage**

Shall comply with Ordinance standards for the MUDD Zoning District. Main Anchor Tenant shall be allowed 500 s.f. of wall signage at the top of the building on each different face. All signage below shall comply with Ordinance.

**X. Lighting:**

All necessary lighting shall be full cut-off type lighting fixtures. Decorative lighting may be installed on buildings for pedestrian and vehicular circulation along the driveways, sidewalks, and parking areas. Exterior accent/architectural lighting shall be permitted.

**XI. Easement Area**

Except for minor areas as shown on the Rezoning Plan to be resolved with the easement holder, Petitioner shall not extend development into the area marked as the Duke Energy Easement to allow for space for streetscape improvements in the future to be constructed by others in coordination with the easement holder.

**XII. Amendments to the Rezoning Plan:**

Future amendments to the Rezoning Plan may be applied for by the then Owner or Owners of the applicable Lot of the Site affected by such amendment in accordance with the provisions herein and of Section 6.207 of the Ordinance.

**XIII. Binding Effect of the Rezoning Application:**

If this Rezoning Petition is approved, all conditions applicable to the development of the Site imposed under the Rezoning Plan will, unless amended in the manner provided herein and under the Ordinance, be binding upon and inure to the benefit of the Petitioner and subsequent owners of the Site or Lot(s), as applicable, and their respective heirs, devisees, personal representatives, successors in interest or assigns.



4725 PIEDMONT ROW DRIVE  
SUITE 800  
CHARLOTTE, NC 28210  
(704) 714-7600  
www.lincolnharris.com

227 WEST TRADE STREET SUITE 700  
CHARLOTTE, NORTH CAROLINA 28202  
TEL. 704.333.6666 FAX 704.333.2926  
WWW.LS3P.COM

**PHILLIPS PLACE  
REZONING**

DATE: 8 APRIL 2022  
PETITION NO: 2021-151

**REVISIONS:**

No.	Description	Date
1	REVISIONS PER STAFF REVIEW COMMENTS	11/15/21
2	REVISIONS PER STAFF REVIEW COMMENTS	12/13/21
3	REVISIONS PER STAFF REVIEW COMMENTS	01/17/22
5	REVISIONS PER STAFF REVIEW COMMENTS	01/17/21
6	REVISIONS PER STAFF REVIEW COMMENTS	03/24/22
7	REVISIONS PER STAFF REVIEW COMMENTS	04/11/22

**DEVELOPMENT  
STANDARDS**

**RZ-2**



VIEW OF TERMINUS TOWER FROM WATERFORD CONDOS

RENDERINGS REPRESENT HEIGHT AND MASS AS VIEWED FROM WATERFORD CONDOS. THEY MAY NOT DEPICT FINAL ARCHIECTURE.

PHILLIPS PLACE TERMINUS TOWER

CHARLOTTE, NC  
24 MARCH 2022





VIEW OF TERMINUS TOWER FROM MOUNTAINBROOK ROAD IN WINTER

RENDERINGS REPRESENT HEIGHT AND MASS AS VIEWED FROM MOUNTAINBROOK ROAD. THEY MAY NOT DEPICT FINAL ARCHIECTURE.

PHILLIPS PLACE TERMINUS TOWER

CHARLOTTE, NC  
24 MARCH 2022





VIEW OF TERMINUS TOWER FROM MOUNTAINBROOK ROAD IN SUMMER

RENDERINGS REPRESENT HEIGHT AND MASS AS VIEWED FROM MOUNTAINBROOK ROAD. THEY MAY NOT DEPICT FINAL ARCHIECTURE.

PHILLIPS PLACE TERMINUS TOWER

CHARLOTTE, NC  
24 MARCH 2022





**LINCOLN HARRIS**

4725 PIEDMONT ROW DRIVE  
SUITE 800  
CHARLOTTE, NC 28210  
(704) 714-7600  
www.lincolnharris.com

227 WEST TRADE STREET SUITE 700  
CHARLOTTE, NORTH CAROLINA 28202  
TEL. 704.333.6686 FAX 704.333.2926  
WWW.LS3P.COM

**PHILLIPS PLACE  
REZONING**

DATE: 8 APRIL 2022  
PETITION NO: 2021-151

REVISIONS:

No.	Description	Date
7	REVISIONS PER STAFF REVIEW COMMENTS	04/11/22

**SITE  
SECTIONS**

**RZ-6**

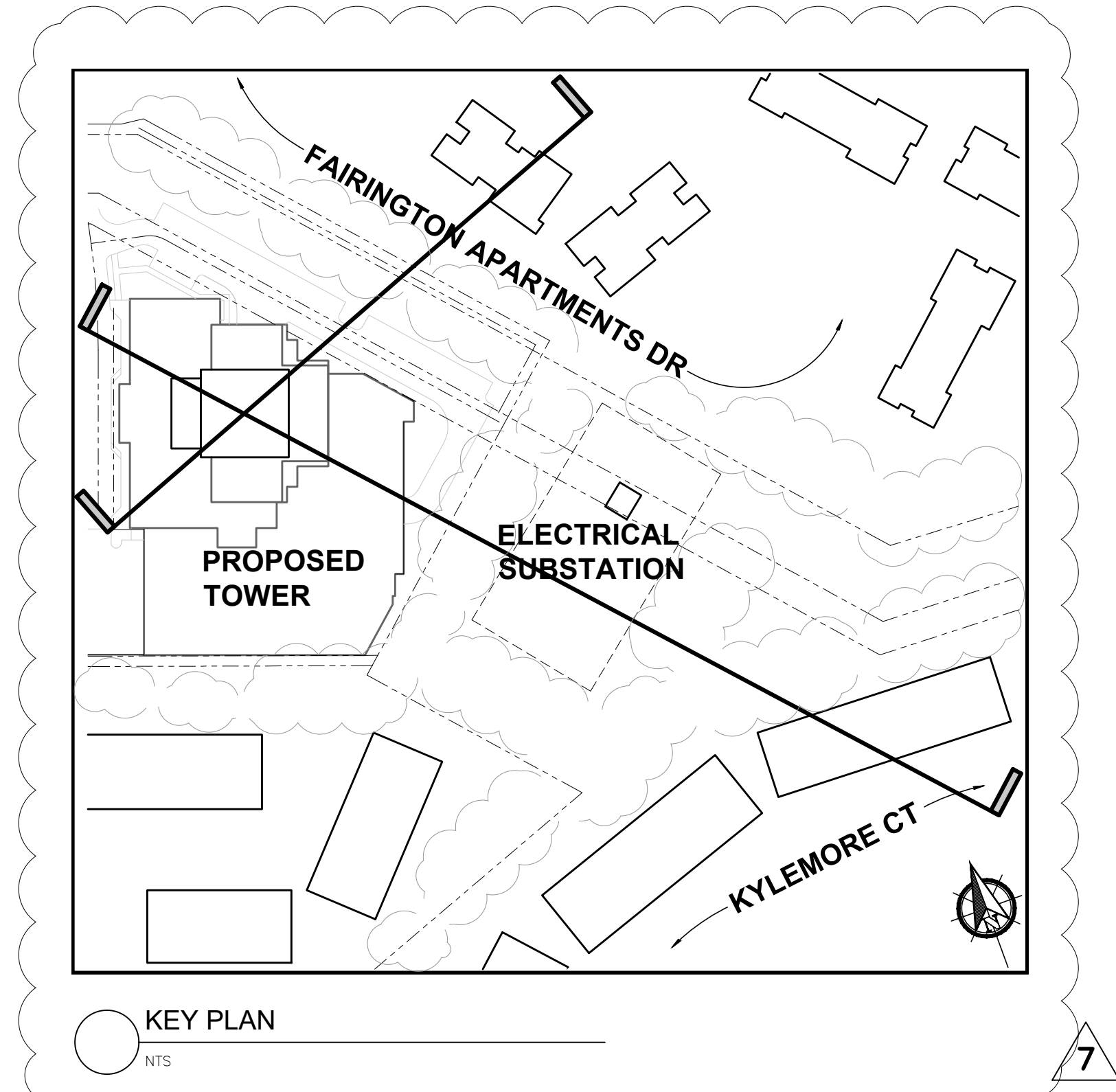
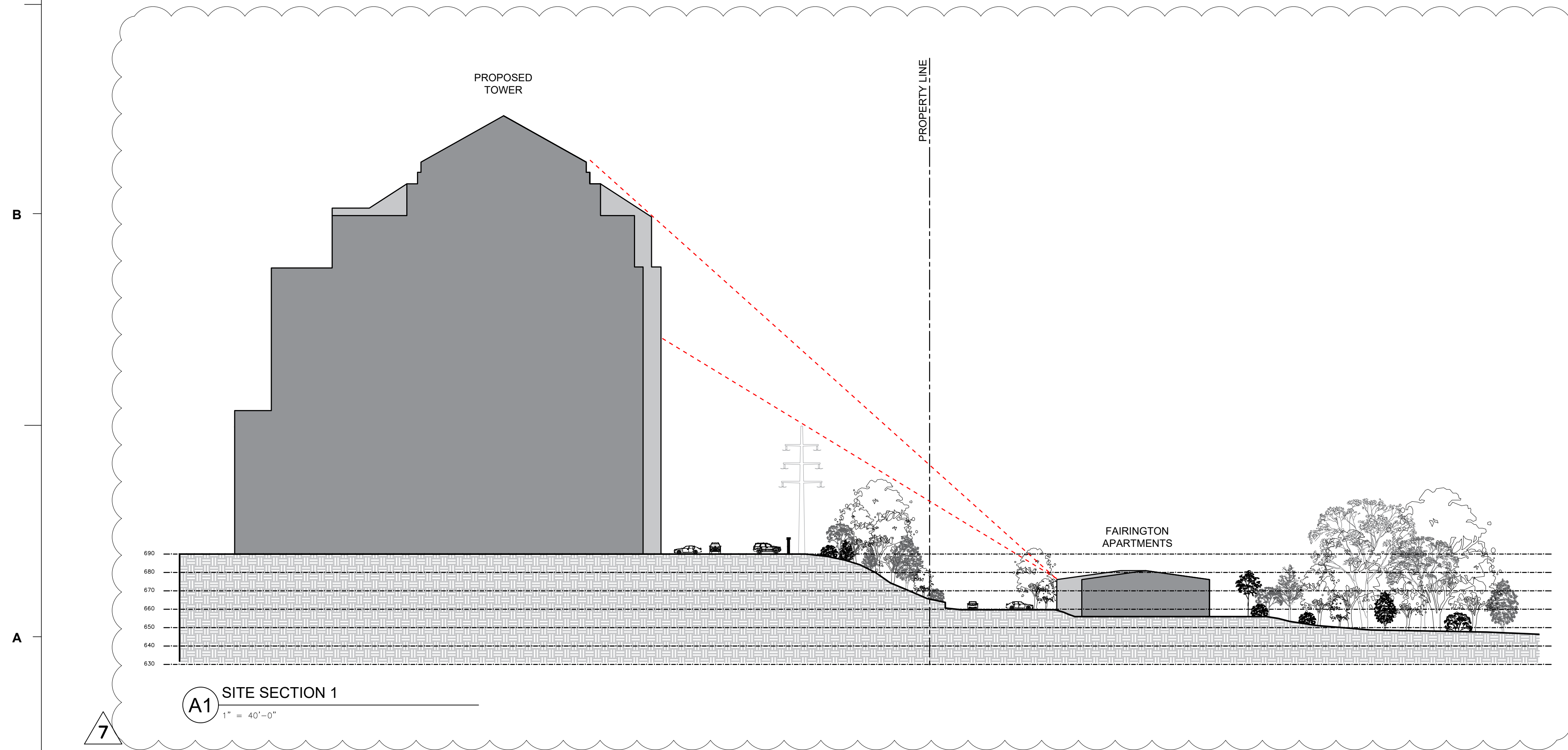
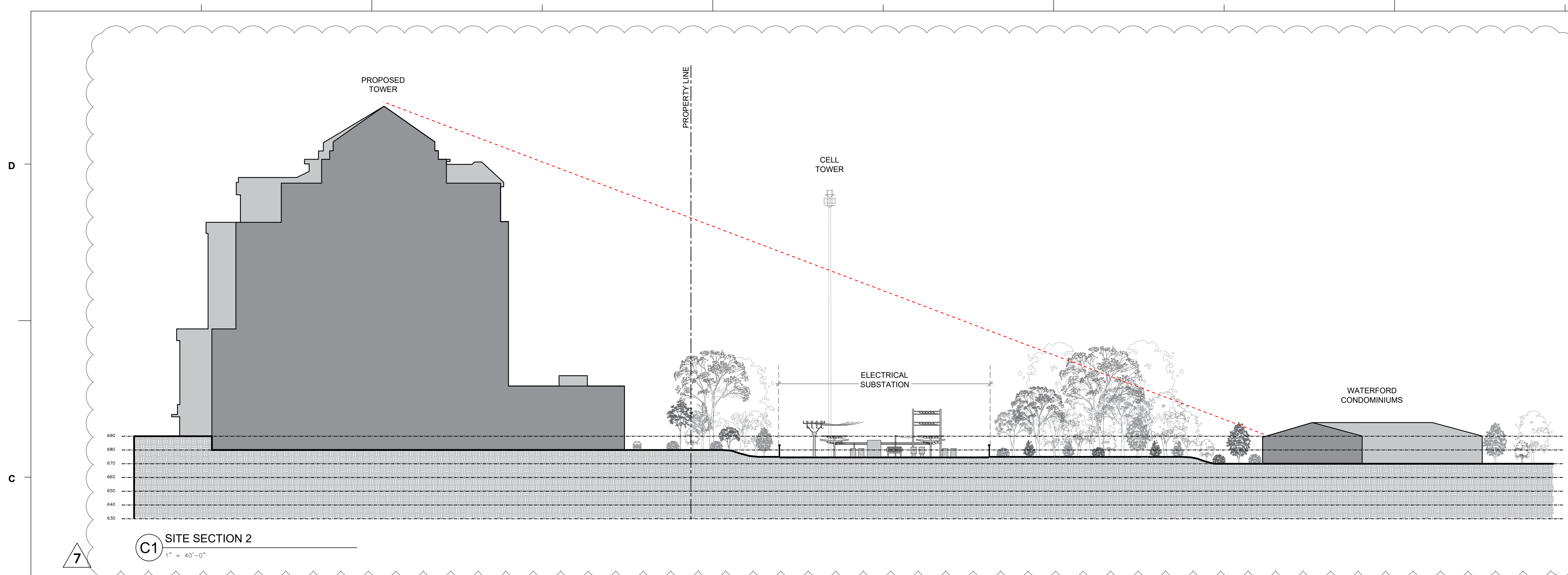

1 2 3 4 5