

SITE DEVELOPMENT DATA

ACREAGE: ± 3.65 AC

TAX PARCELS: PORTION OF 183-141-13
PORTION OF 183-141-17

EXISTING ZONING: MUDD-O

PROPOSED ZONING: MUDD-O SPA

EXISTING USES: Commercial

PROPOSED USES: Uses permitted by right and under prescribed conditions together with accessory uses, as allowed in the MUDD zoning district not otherwise limited in the Rezoning Plan.

MAX. DEVELOPMENT: Up to 250,000 square feet of office uses; and
Up to 20,000 square feet of retail, EDEE or personal service or other commercial uses.

MAX. BLDG. HEIGHT: Up to 250 feet, per the Optional Provision in Section II

PARKING: As required by the Ordinance for the MUDD zoning district.

LEGEND

- SETBACK
 - ▨ EXISTING OPEN SPACE
 - ▩ ADDITIONAL OPEN SPACE
 - DEVELOPMENT AREA
 - ➔ EXISTING ACCESS TO REMAIN
 - REZONING BOUNDARY**
 - PARCEL BOUNDARY
 - EASEMENT
 - PRIMARY FACADE
- **REZONING BOUNDARIES TO FOLLOW PARCEL LINES U.N.O.

VICINITY MAP NTS

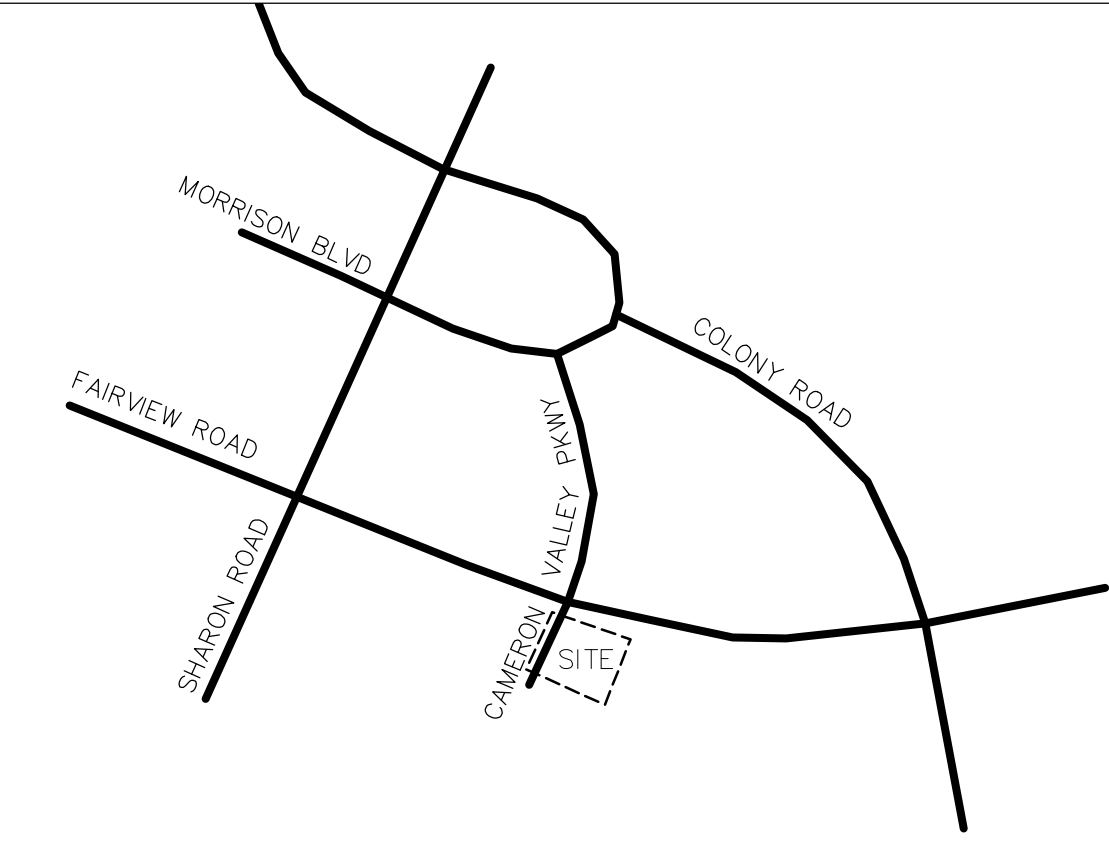

227 WEST TRADE STREET SUITE 700
CHARLOTTE, NORTH CAROLINA 28202
TEL. 704.333.6686 FAX 704.333.2926
WWW.LS3P.COM

PHILLIPS PLACE REZONING

DATE: 8 APRIL 2022
PETITION NO: 2021-151

REVISIONS:

No.	Description	Date
1	REVISIONS PER STAFF REVIEW COMMENTS	11/15/21
2	REVISIONS PER STAFF REVIEW COMMENTS	12/13/21
3	REVISIONS PER STAFF REVIEW COMMENTS	01/17/21
4	REVISIONS PER STAFF REVIEW COMMENTS	02/14/21
5	REVISIONS PER STAFF REVIEW COMMENTS	03/24/22
7	REVISIONS PER STAFF REVIEW COMMENTS	04/11/22

TECHNICAL DATA SHEET

RZ-1A

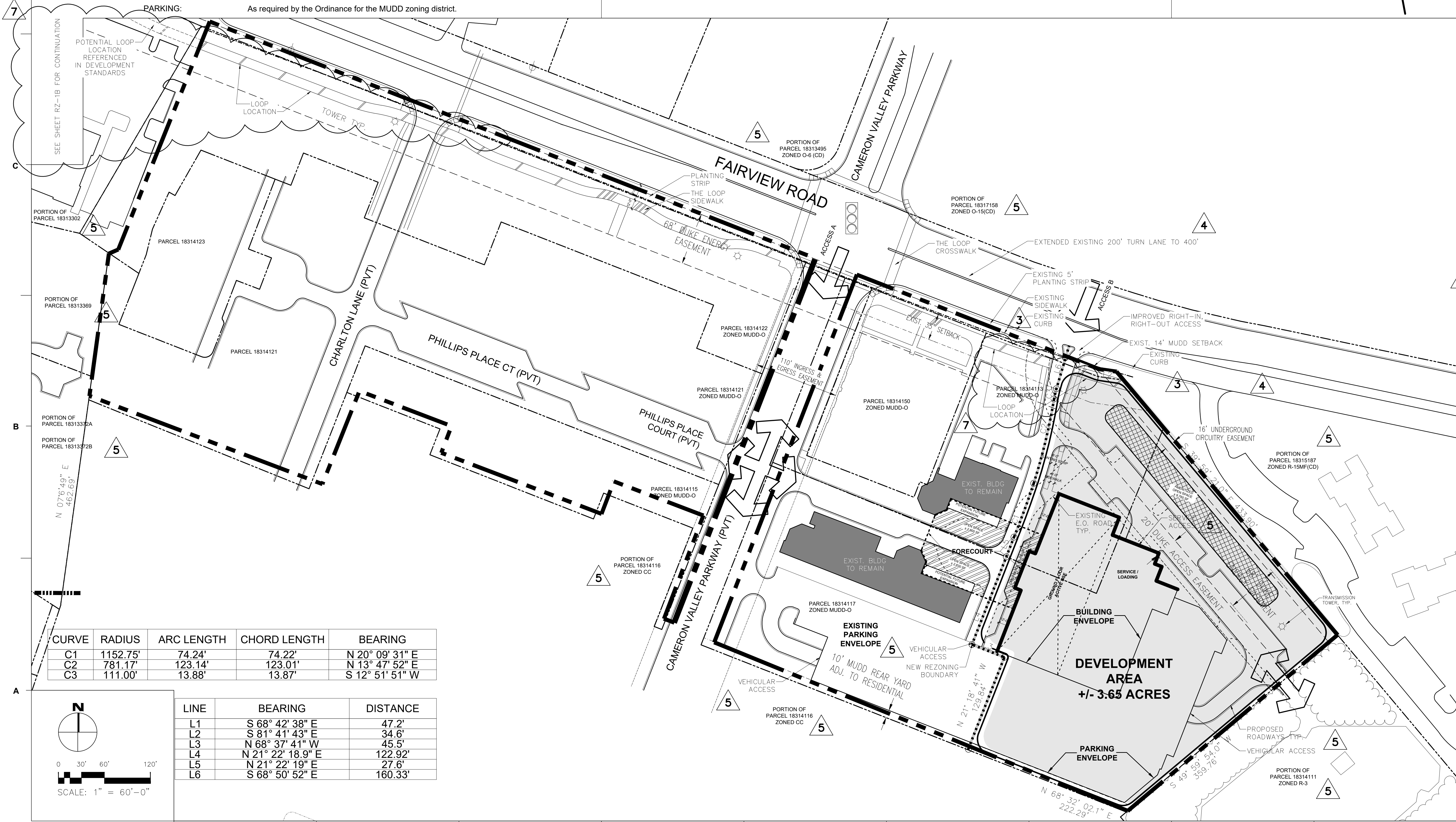

CURVE	RADIUS	ARC LENGTH	CHORD LENGTH	BEARING
C1	1152.75'	74.24'	74.22'	N 20° 09' 31" E
C2	781.17'	123.14'	123.01'	N 13° 47' 52" E
C3	111.00'	13.88'	13.87'	S 12° 51' 51" W

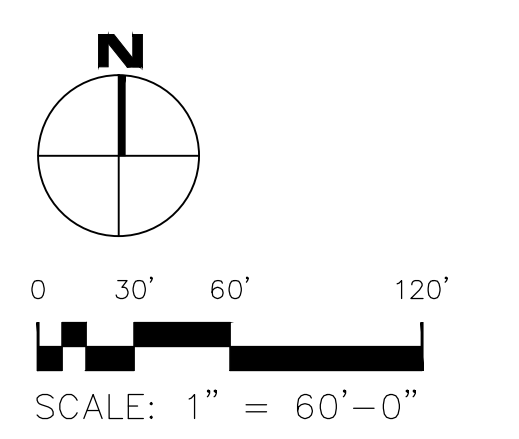

LINE	BEARING	DISTANCE
L1	S 68° 42' 38" E	47.2'
L2	S 81° 41' 43" E	34.6'
L3	N 68° 37' 41" W	45.5'
L4	N 21° 22' 18.9" E	122.92'
L5	N 21° 22' 19" E	27.6'
L6	S 68° 50' 52" E	160.33'

SITE DEVELOPMENT DATA

ACREAGE: ± 3.65 AC

TAX PARCELS: PORTION OF 183-141-13
PORTION OF 183-141-17

EXISTING ZONING: MUDD-O

PROPOSED ZONING: MUDD-O SPA

EXISTING USES: Commercial

PROPOSED USES: Uses permitted by right and under prescribed conditions together with accessory uses, as allowed in the MUDD zoning district not otherwise limited in the Rezoning Plan.

MAX. DEVELOPMENT: Up to 250,000 square feet of office uses; and
Up to 20,000 square feet of retail, EDEE or personal service or other commercial uses.

MAX. BLDG. HEIGHT: Up to 250 feet, per the Optional Provision in Section II

PARKING: As required by the Ordinance for the MUDD zoning district.

LEGEND

- SETBACK
 - ▨ EXISTING OPEN SPACE
 - ▩ ADDITIONAL OPEN SPACE
 - DEVELOPMENT AREA
 - EXISTING ACCESS TO REMAIN
 - REZONING BOUNDARY**
 - PARCEL BOUNDARY
 - EASEMENT
 - PRIMARY FACADE
- **REZONING BOUNDARIES TO FOLLOW PARCEL LINES U.N.O.

VICINITY MAP NTS

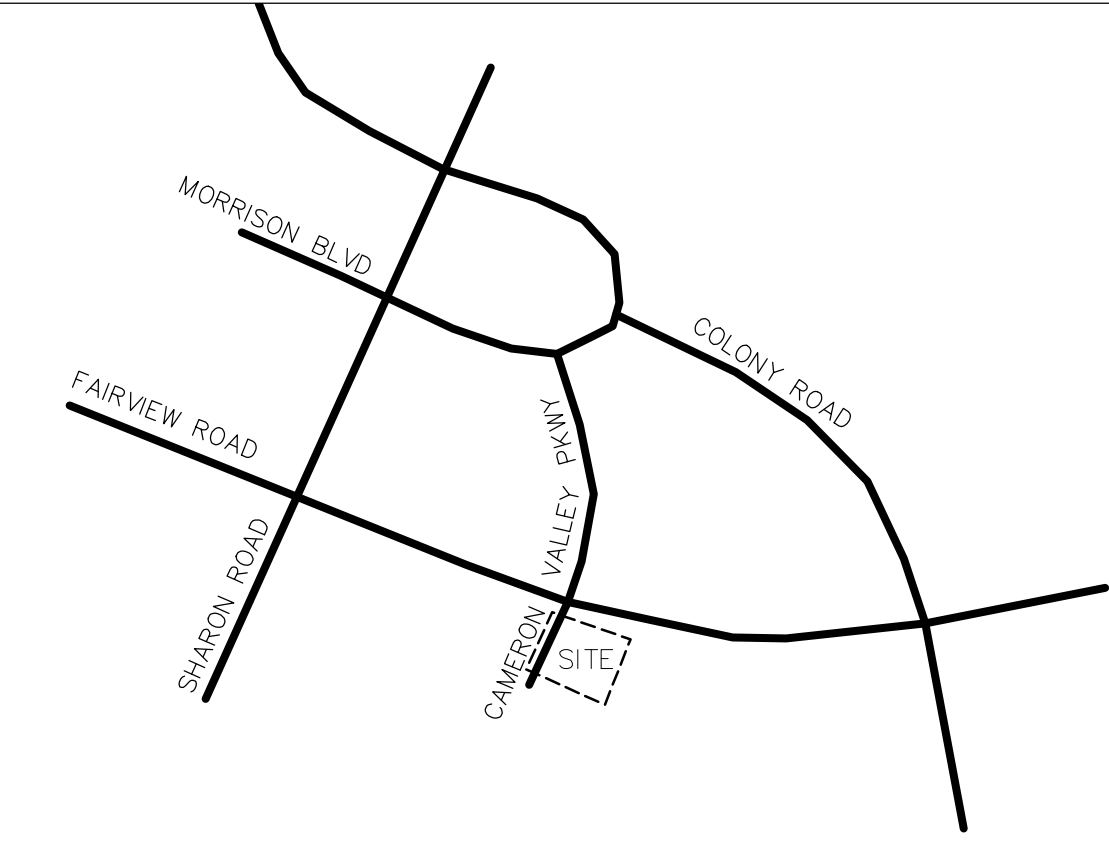

227 WEST TRADE STREET SUITE 700
CHARLOTTE, NORTH CAROLINA 28202
TEL. 704.333.6686 FAX 704.333.2926
WWW.LS3P.COM

PHILLIPS PLACE REZONING

DATE: 8 APRIL 2022
PETITION NO: 2021-151

REVISIONS:

No.	Description	Date
1	REVISIONS PER STAFF REVIEW COMMENTS	11/15/21
2	REVISIONS PER STAFF REVIEW COMMENTS	12/13/21
3	REVISIONS PER STAFF REVIEW COMMENTS	01/17/22
4	REVISIONS PER STAFF REVIEW COMMENTS	02/14/22
5	REVISIONS PER STAFF REVIEW COMMENTS	03/24/22
7	REVISIONS PER STAFF REVIEW COMMENTS	04/11/22

TECHNICAL DATA SHEET

RZ-1B

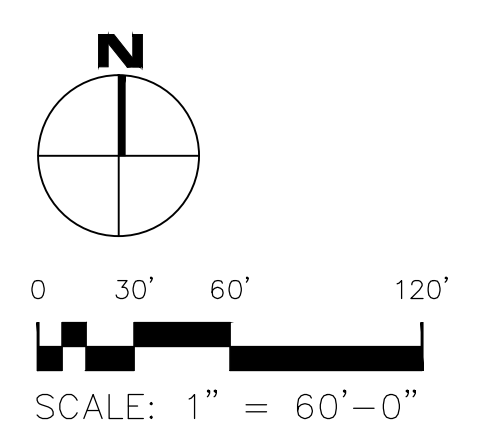
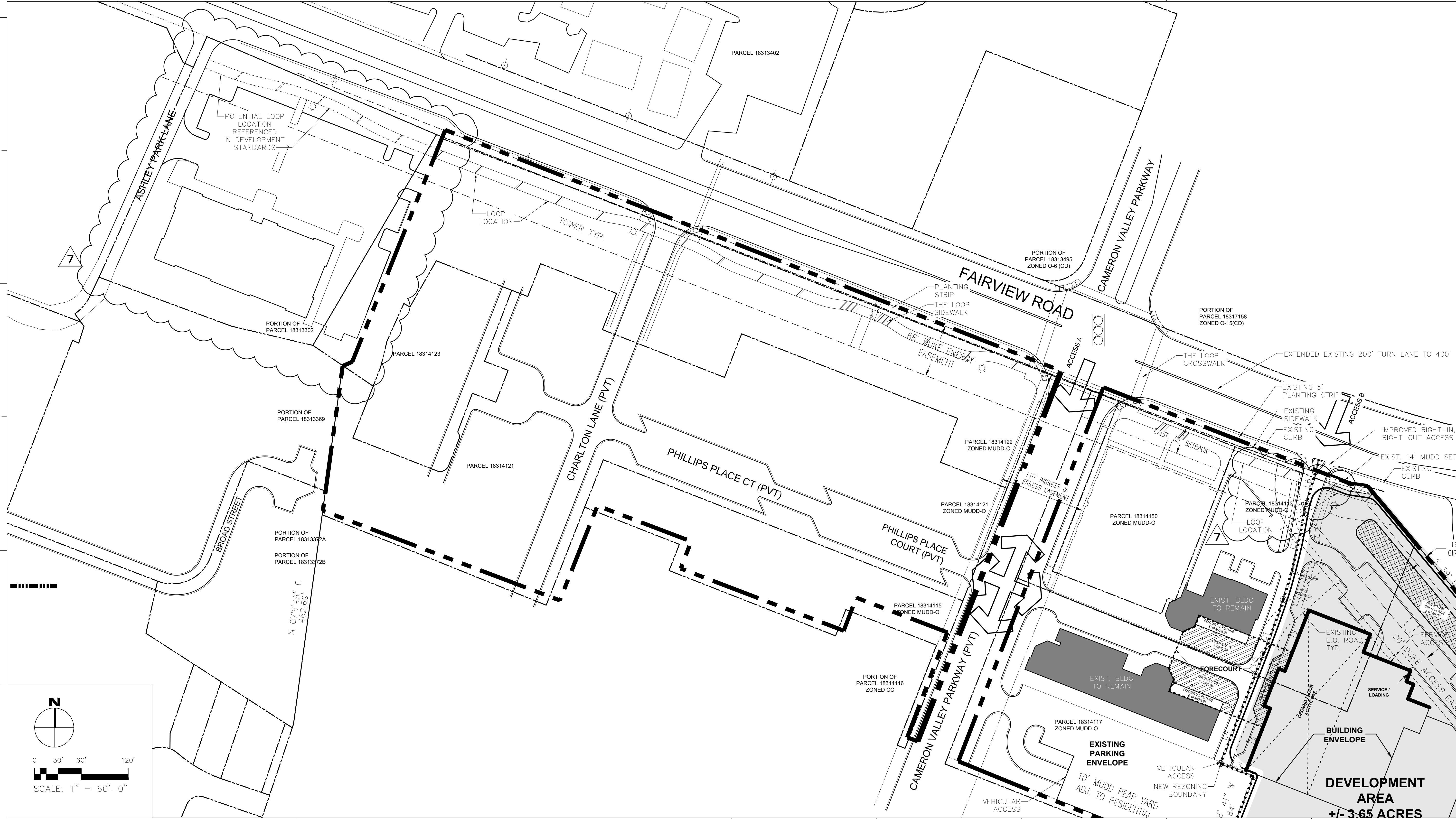

D

C

B

A

1

2

3

4

5

7

5

7



VIEW OF TERMINUS TOWER FROM WATERFORD CONDOS

RENDERINGS REPRESENT HEIGHT AND MASS AS VIEWED FROM WATERFORD CONDOS. THEY MAY NOT DEPICT FINAL ARCHIECTURE.

PHILLIPS PLACE TERMINUS TOWER

CHARLOTTE, NC
24 MARCH 2022





VIEW OF TERMINUS TOWER FROM MOUNTAINBROOK ROAD IN WINTER

RENDERINGS REPRESENT HEIGHT AND MASS AS VIEWED FROM MOUNTAINBROOK ROAD. THEY MAY NOT DEPICT FINAL ARCHIECTURE.

PHILLIPS PLACE TERMINUS TOWER

CHARLOTTE, NC
24 MARCH 2022





VIEW OF TERMINUS TOWER FROM MOUNTAINBROOK ROAD IN SUMMER

RENDERINGS REPRESENT HEIGHT AND MASS AS VIEWED FROM MOUNTAINBROOK ROAD. THEY MAY NOT DEPICT FINAL ARCHIECTURE.

PHILLIPS PLACE TERMINUS TOWER

CHARLOTTE, NC
24 MARCH 2022





LINCOLN HARRIS

4725 PIEDMONT ROW DRIVE
SUITE 800
CHARLOTTE, NC 28210
(704) 714-7600
www.lincolnharris.com

227 WEST TRADE STREET SUITE 700
CHARLOTTE, NORTH CAROLINA 28202
TEL. 704.333.6666 FAX 704.333.2926
WWW.LS3P.COM

**PHILLIPS PLACE
REZONING**

DATE: 8 APRIL 2022
PETITION NO: 2021-151

REVISIONS:

No.	Description	Date
7	REVISIONS PER STAFF REVIEW COMMENTS	04/11/22

SITE SECTIONS

RZ-6

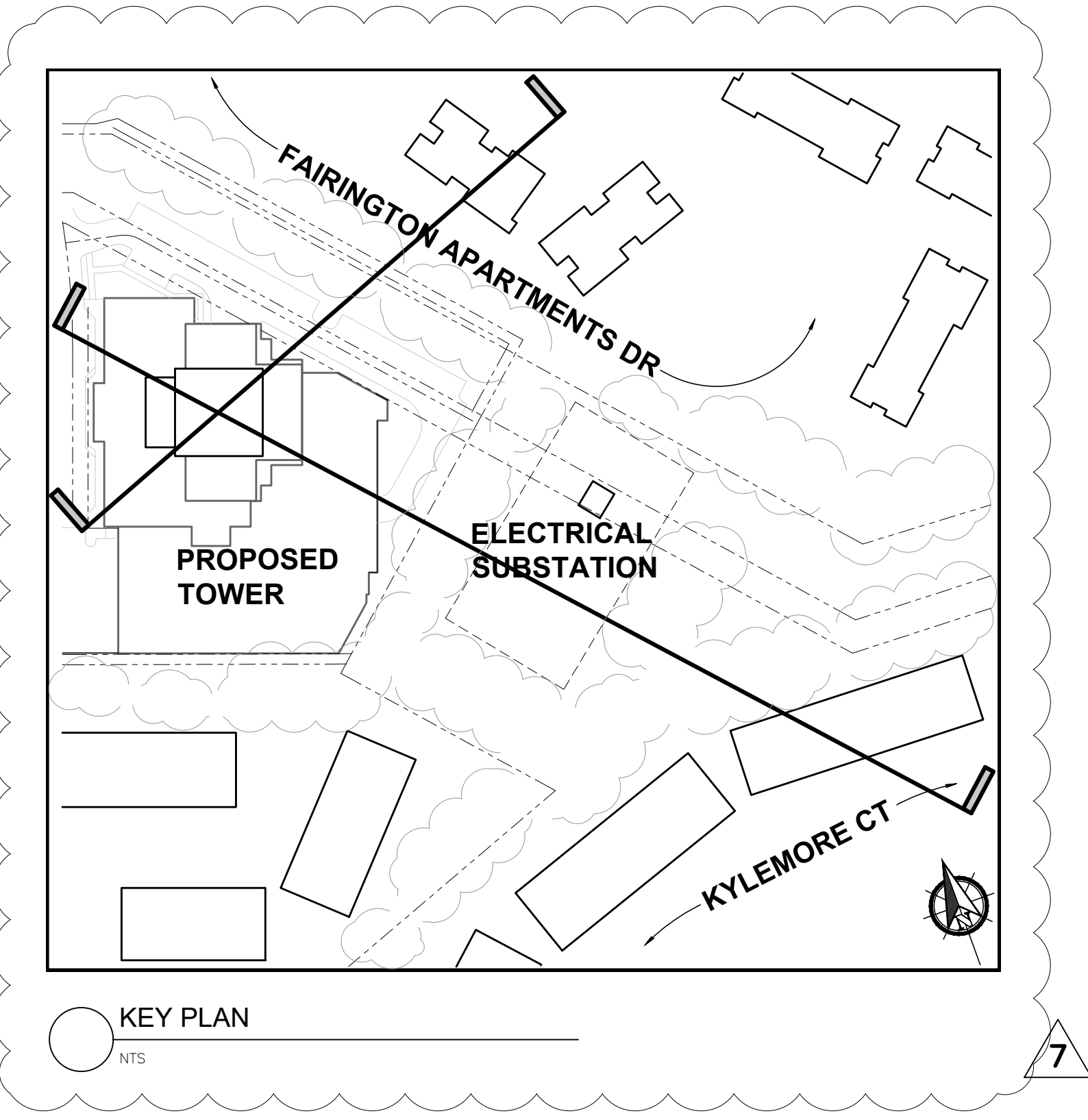
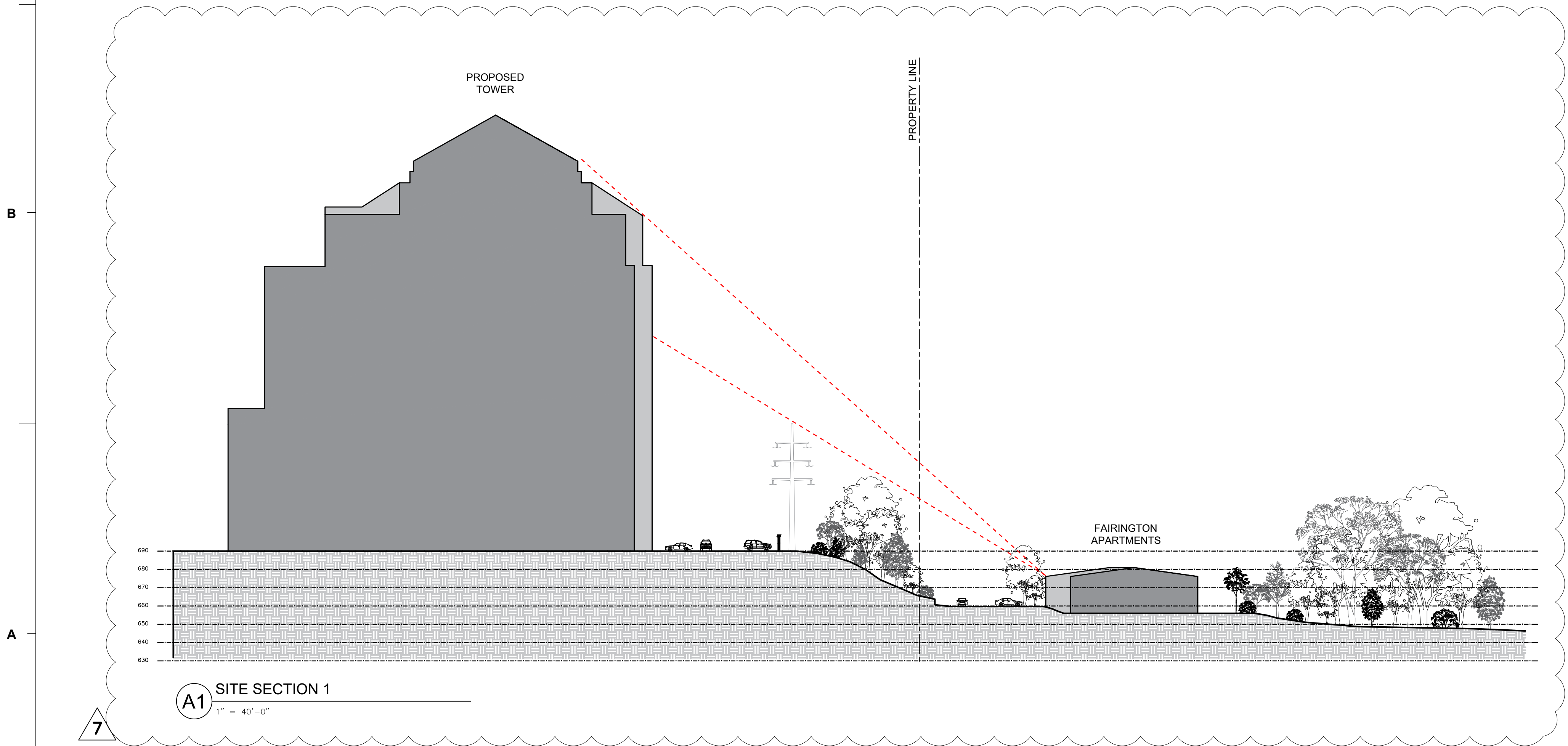
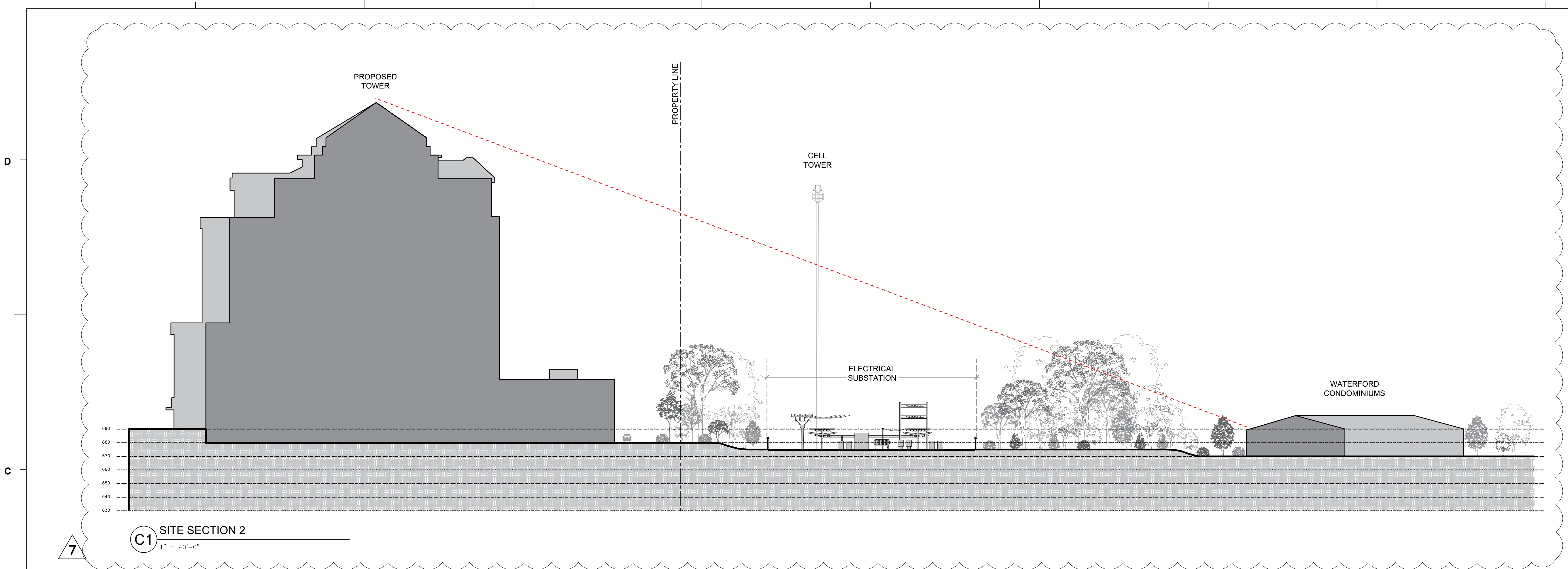

1 2 3 4 5