

VICINITY MAP  
NOT TO SCALE

LEGEND	
	AREA OUTLINE / PROPERTY LINE
	POTENTIAL PARKING ENVELOPE
	POTENTIAL BUILDING ENVELOPE
	POTENTIAL MOVEMENT ACCESS POINTS

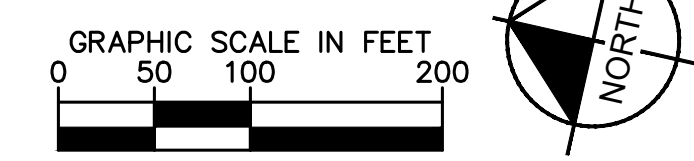
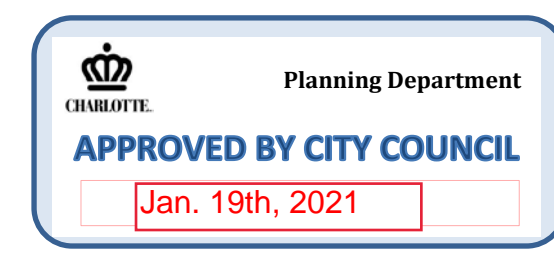

Plotted By: Houston, Justin | Sheet Set: WSB Retail | Layout: RZ-1 | TECHNICAL DATA SHEET | December 28, 2020 | 02:16:00 pm | K:\CHL\_PRA\013187000 | web\_retail\_0000.pcr\_mixed\_use\_02 | DWG | Plans: RZ-1 | TECHNICAL DATA SHEET | Large.dwg  
 This document, together with the concepts and designs presented herein, is the property of Kimley-Horn and Associates, Inc. and is intended only for the specific use and client for which it was prepared. Reuse of any information contained herein without written authorization from Kimley-Horn and Associates, Inc. shall be without liability to Kimley-Horn and Associates, Inc.

NO.
REVISIONS
DATE

© 2020 KIMLEY-HORN AND ASSOCIATES, INC.  
200 SOUTH TRYON, SUITE 200, CHARLOTTE, NC 28202  
PHONE: 704-333-5131  
WWW.KIMLEY-HORN.COM

**TECHNICAL DATA SHEET**

PCRMIXED USE  
PREPARED FOR  
WSB RETAIL

REZONING PETITION NO. 2020-088

KHA PROJECT  
013187000

DATE  
05/15/2020

SCALE  
AS SHOWN

DESIGNED BY

DRAWN BY

CHECKED BY

CITY OF CHARLOTTE

SHEET NUMBER  
**RZ-1**

NC



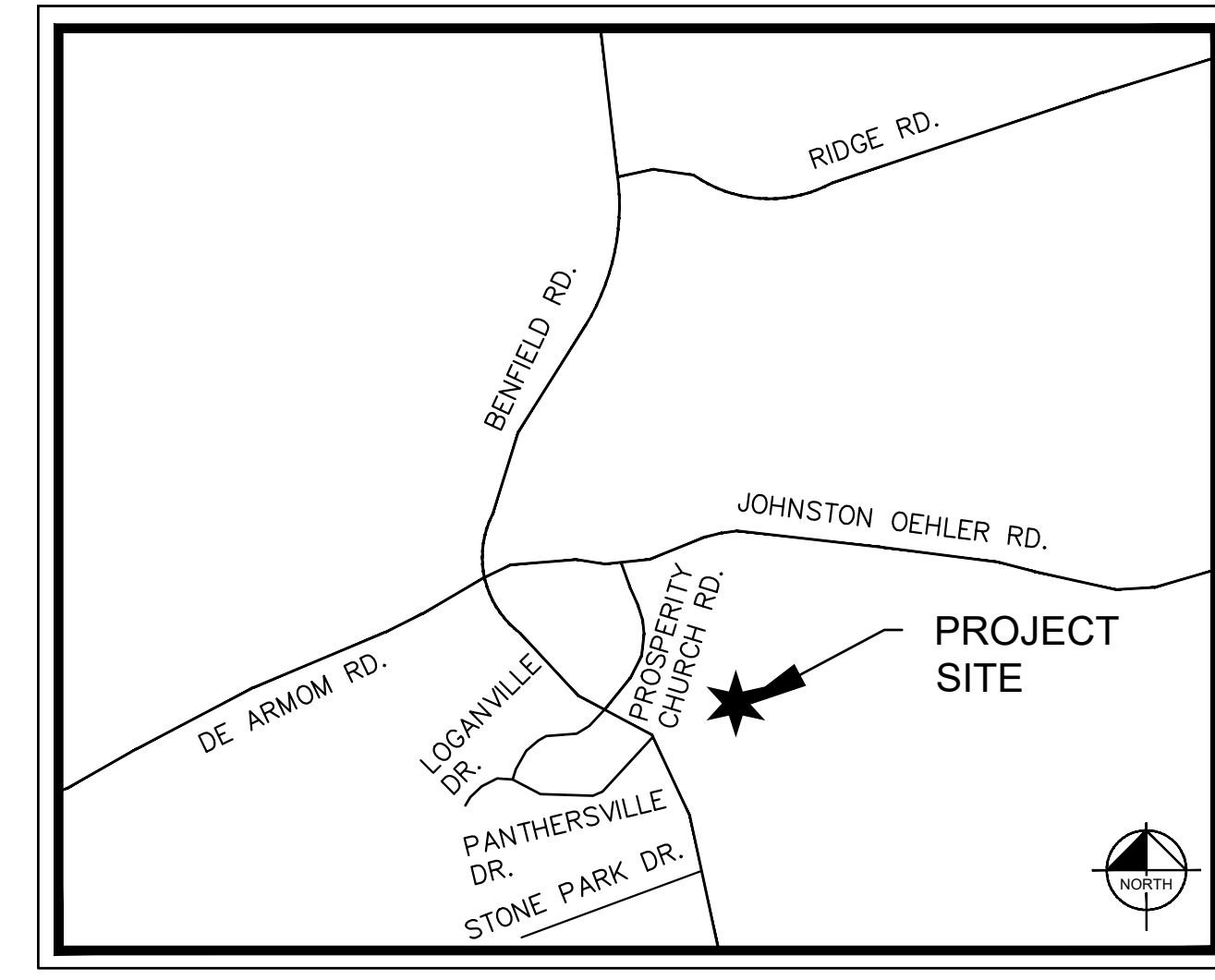
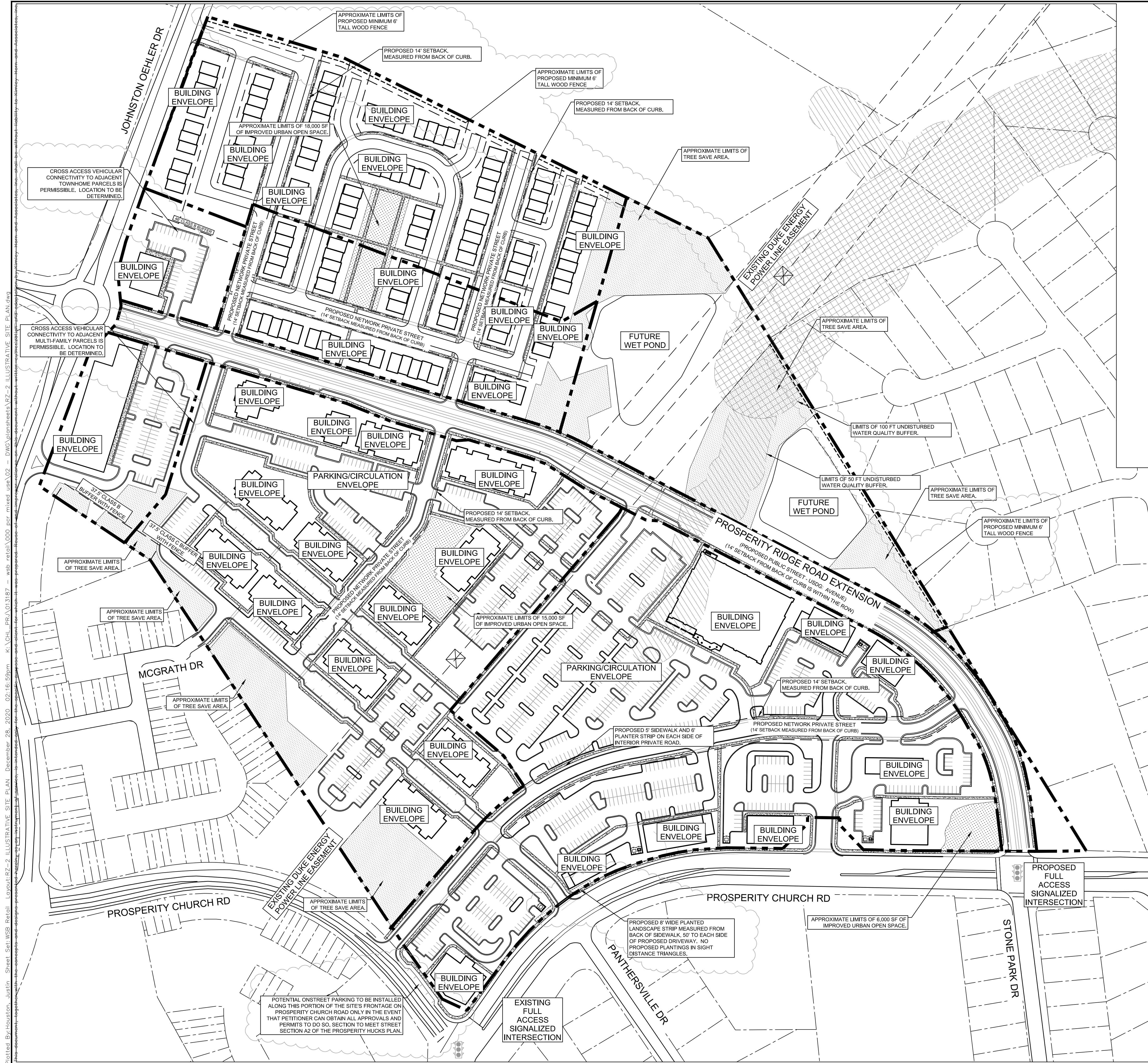

VICINITY MAP  
NOT TO SCALE

Plotted By: Houston, Justin Sheet Set: WSB Retail Layout: RZ-2 ILLUSTRATIVE SITE PLAN December 28, 2020 02:16:49pm K:\DHL\PROJECTS\13187\ - web retail\000 pcr mixed use\02 - DWG\00\streets\RZ-2 ILLUSTRATIVE SITE PLAN.dwg

NO.	REVISIONS	DATE	BY

**Kimley»Horn**  
 © 2020 KIMLEY-HORN AND ASSOCIATES, INC.  
 200 SOUTH TRYON, SUITE 200, CHARLOTTE, NC 28202  
 PHONE: 704-333-5131  
 WWW.KIMLEY-HORN.COM

KHA PROJECT	013187000
DATE	05/15/2020
SCALE	AS SHOWN
DESIGNED BY	
DRAWN BY	
CHECKED BY	

**ILLUSTRATIVE SITE PLAN**  
 REZONING PETITION NO. 2020-088

**PCR MIXED USE**  
 PREPARED FOR  
**WSB RETAIL**  
 CITY OF CHARLOTTE, NC  
 SHEET NUMBER  
**RZ-2**

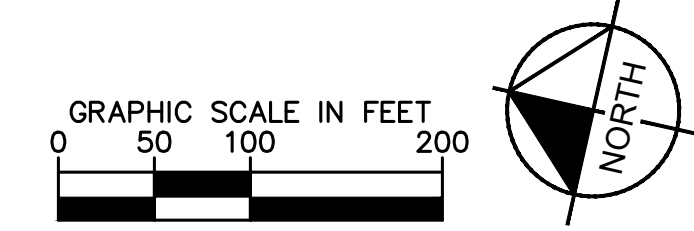



Plotted By: Houston, Justin Sheet Set: WSB Retail Layout: RZ-3 DEVELOPMENT AREA PLAN December 28, 2020 02:18:18pm K:\CHL\_PRA\03187-3 DEVELOPMENT AREA SITE PLANS.dwg  
 This document, together with the concepts and designs presented herein, is intended solely for the use of the client and is not to be used for any other purpose without the written authorization and consent of Kimley-Horn and Associates, Inc. All rights are reserved. Kimley-Horn and Associates, Inc. shall be without liability to Kimley-Horn and Associates, Inc.

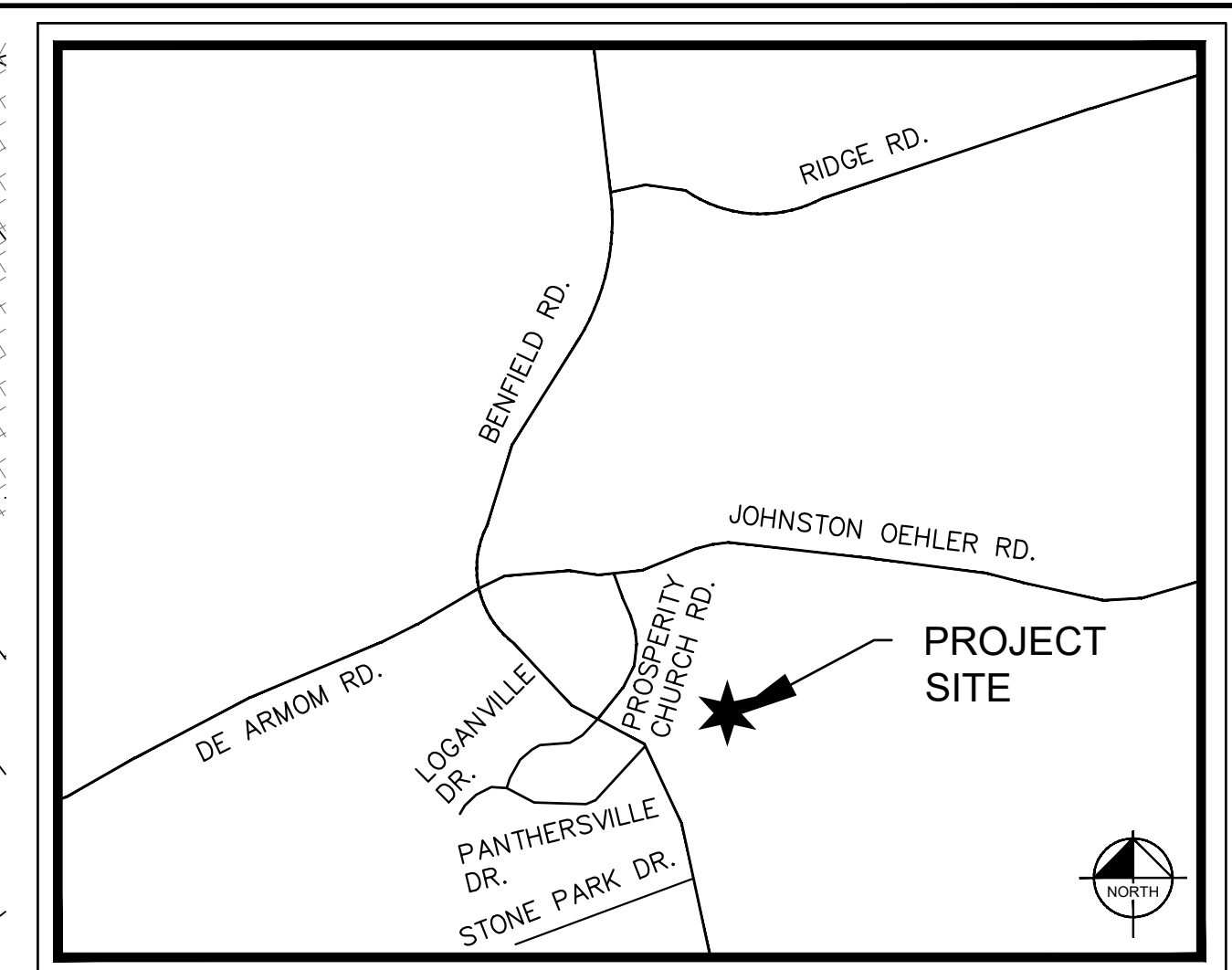
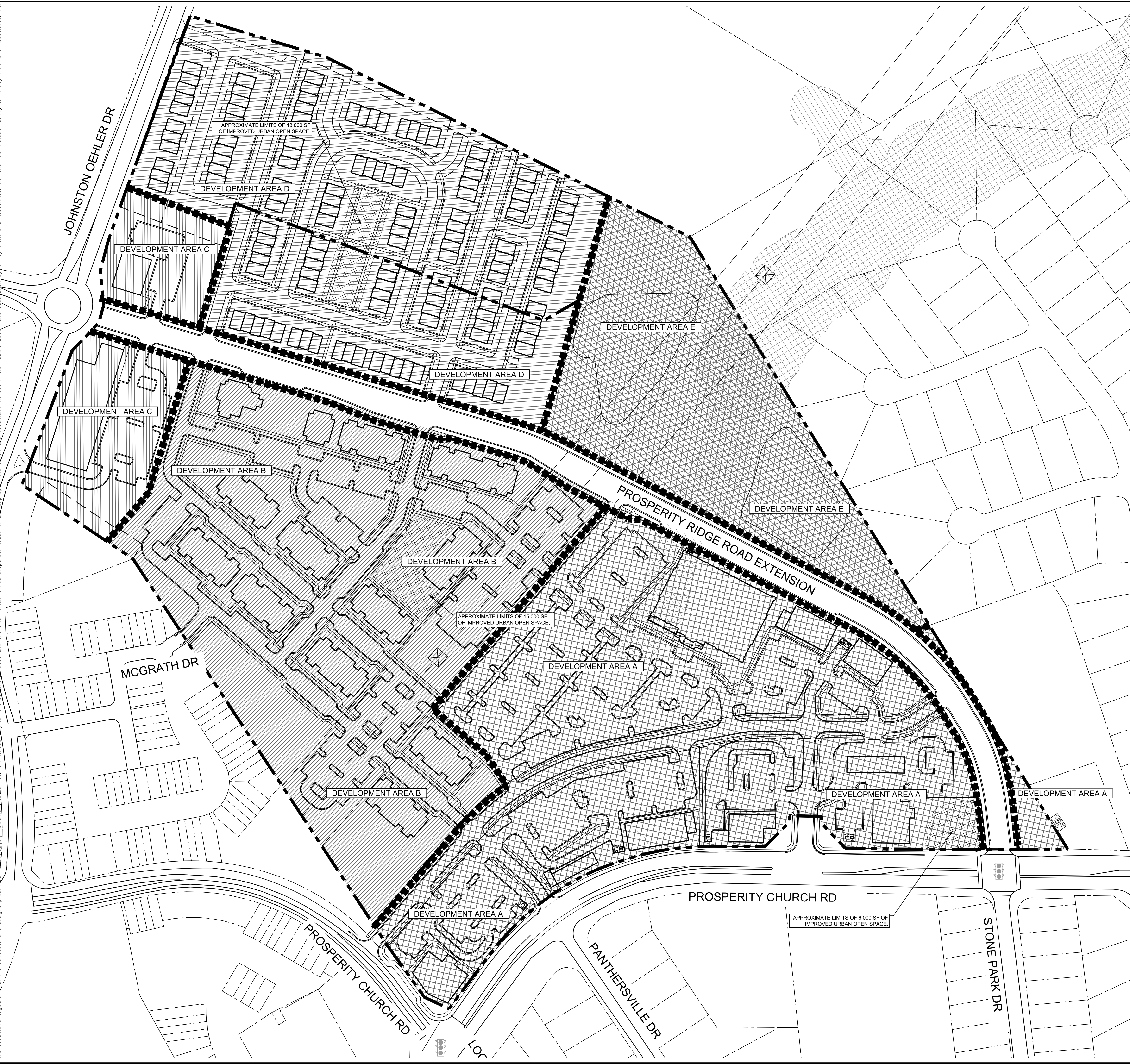

**VICINITY MAP**  
NOT TO SCALE

LEGEND	
	AREA OUTLINE / PROPERTY LINE
	DEVELOPMENT AREA A
	DEVELOPMENT AREA B
	DEVELOPMENT AREA C
	DEVELOPMENT AREA D
	DEVELOPMENT AREA E



<b>Kimley»Horn</b> <small>© 2020 KIMLEY-HORN AND ASSOCIATES, INC.          200 SOUTH TRYON, SUITE 200, CHARLOTTE, NC 28202          PHONE: 704-333-5131          WWW.KIMLEY-HORN.COM</small>	REVISIONS No. _____ Date _____ By _____
	KHA PROJECT 013187000 DATE 05/15/2020 SCALE AS SHOWN DESIGNED BY _____ DRAWN BY _____ CHECKED BY _____
<b>DEVELOPMENT AREA PLAN</b>	REZONING PETITION NO. 2020-088
<b>PCR MIXED USE</b> PREPARED FOR <b>WSB RETAIL</b>	CITY OF CHARLOTTE NC
SHEET NUMBER <b>RZ-3</b>	DATE



Plotted By: Houston, Justin | Sheet: WSB Retail | Layout: RZ-4 | Notes: December 28, 2020 02:19:22pm | K:\CHL-FRA\0119187 - web retail\000\_per\_mixed\_use\02 - DWG\planisheets\RZ-4 | ILLUSTRATIVE SITE PLAN NOTES.dwg | This document, together with the concepts and designs presented herein, as an instrument of service, is intended only for the specific purpose and client for which it was prepared. Reuse of and improper reliance on this document without written authorization and adaptation by Kimley-Horn and Associates, Inc. shall be without liability to Kimley-Horn and Associates, Inc.

**DEVELOPMENT STANDARDS**

DECEMBER 28, 2020

**1. GENERAL PROVISIONS**

- A. THESE DEVELOPMENT STANDARDS FORM A PART OF THE REZONING PLAN (COMPRISED OF THE TECHNICAL DATA SHEET, ILLUSTRATIVE SITE PLAN, DEVELOPMENT AREA SHEET, DEVELOPMENT STANDARDS SHEETS AND PROPOSED ZONING KEY MAP) ASSOCIATED WITH THE REZONING PETITION FILED BY WSB RETAIL PARTNERS, LLC (HEREINAFTER REFERRED TO AS THE "PETITIONER") TO ACCOMMODATE A MULTI-USE DEVELOPMENT ON AN APPROXIMATELY 58.0411 ACRE SITE LOCATED ON PROSPERITY CHURCH ROAD, WHICH SITE IS MORE PARTICULARLY DEPICTED ON THE REZONING PLAN (HEREINAFTER REFERRED TO AS THE "SITE"). THE SITE IS COMPRISED OF THOSE PARCELS OF LAND DESIGNATED AS TAX PARCEL NOS. 029-321-12, 029-321-33, 029-321-32, 029-321-06, 029-321-13, 029-321-21 AND 029-321-05.
- B. FOR ENTITLEMENT PURPOSES, THE SITE IS DIVIDED INTO FIVE SEPARATE DEVELOPMENT AREAS THAT ARE DESIGNATED ON THE REZONING PLAN AS DEVELOPMENT AREA A, DEVELOPMENT AREA B, DEVELOPMENT AREA C, DEVELOPMENT AREA D AND DEVELOPMENT AREA E. BUILDING ENVELOPES AND PARKING ENVELOPES ARE LOCATED WITHIN DEVELOPMENT AREA A, DEVELOPMENT AREA B, DEVELOPMENT AREA C AND DEVELOPMENT AREA D AND ARE DEPICTED ON THE TECHNICAL DATA SHEET. ALL PRINCIPAL BUILDINGS AND ACCESSORY STRUCTURES LOCATED WITHIN DEVELOPMENT AREA A, DEVELOPMENT AREA B, DEVELOPMENT AREA C AND DEVELOPMENT AREA D SHALL BE LOCATED WITHIN A BUILDING ENVELOPE, AND ALL PARKING AREAS LOCATED WITHIN DEVELOPMENT AREA A, DEVELOPMENT AREA B, DEVELOPMENT AREA C AND DEVELOPMENT AREA D SHALL BE LOCATED WITHIN A PARKING ENVELOPE. THIS REZONING PLAN DOES NOT LIMIT THE NUMBER OF PRINCIPAL BUILDINGS AND ACCESSORY STRUCTURES THAT MAY BE LOCATED WITHIN A BUILDING ENVELOPE LOCATED IN DEVELOPMENT AREA A, DEVELOPMENT AREA B, DEVELOPMENT AREA C AND DEVELOPMENT AREA D. ANY REFERENCE HEREIN TO THE SITE SHALL BE DEEMED TO INCLUDE DEVELOPMENT AREA A, DEVELOPMENT AREA B, DEVELOPMENT AREA C, DEVELOPMENT AREA D AND DEVELOPMENT AREA E UNLESS OTHERWISE NOTED HEREIN.
- C. THE DEVELOPMENT AND USE OF THE SITE WILL BE GOVERNED BY THE REZONING PLAN, THESE DEVELOPMENT STANDARDS AND THE APPLICABLE PROVISIONS OF THE CITY OF CHARLOTTE ZONING ORDINANCE (THE "ORDINANCE"). UNLESS THE REZONING PLAN OR THESE DEVELOPMENT STANDARDS ESTABLISH MORE STRINGENT STANDARDS, THE REGULATIONS ESTABLISHED UNDER THE ORDINANCE FOR THE COMMERCIAL CENTER (CC) ZONING DISTRICT SHALL GOVERN THE DEVELOPMENT AND USE OF THOSE PORTIONS OF THE SITE DESIGNATED AS DEVELOPMENT AREA A, DEVELOPMENT AREA B, DEVELOPMENT AREA C AND DEVELOPMENT AREA E. UNLESS THE REZONING PLAN OR THESE DEVELOPMENT STANDARDS ESTABLISH MORE STRINGENT STANDARDS, THE REGULATIONS ESTABLISHED UNDER THE ORDINANCE FOR THE UR-2 ZONING DISTRICT SHALL GOVERN THE DEVELOPMENT AND USE OF THAT PORTION OF THE SITE DESIGNATED AS DEVELOPMENT AREA D.
- D. THE DEVELOPMENT AND USES DEPICTED ON THE ILLUSTRATIVE SITE PLAN ARE SCHEMATIC IN NATURE AND ARE INTENDED TO DEPICT THE GENERAL ARRANGEMENT OF USES AND IMPROVEMENTS ON THE SITE. ACCORDINGLY, THE LAYOUT, LOCATIONS AND SIZES OF THE USES, IMPROVEMENTS AND SITE ELEMENTS DEPICTED ON THE ILLUSTRATIVE SITE PLAN AS WELL AS THE INTERNAL STREETS, DRIVES AND PARKING AREAS ARE SCHEMATIC IN NATURE AND, SUBJECT TO THE TERMS OF THESE DEVELOPMENT STANDARDS AND THE ORDINANCE, ARE SUBJECT TO MINOR ALTERATIONS OR MODIFICATIONS DURING THE DESIGN DEVELOPMENT AND CONSTRUCTION DOCUMENT PHASES.
- E. THE DEVELOPMENT OF THE SITE PROPOSED UNDER THIS REZONING PLAN SHALL BE CONSIDERED TO BE A PLANNED/UNIFIED DEVELOPMENT. THEREFORE, SIDE AND REAR YARDS, BUFFERS, BUILDING HEIGHT SEPARATION REQUIREMENTS AND OTHER SIMILAR ZONING STANDARDS SHALL NOT BE REQUIRED INTERNALLY BETWEEN IMPROVEMENTS, USES AND OTHER ELEMENTS LOCATED ON THE SITE. FURTHERMORE, THE PETITIONER AND/OR THE OWNER(S) OF THE SITE RESERVE THE RIGHT TO SUBDIVIDE PORTIONS OR ALL OF THE SITE AND TO CREATE LOTS WITHIN THE INTERIOR OF THE SITE WITHOUT REFERENCE TO ANY SUCH INTERNAL SEPARATION STANDARDS, PROVIDED, HOWEVER, THAT THE DEVELOPMENT OF THE SITE SHALL BE REQUIRED TO MEET ANY APPLICABLE SETBACK, SIDE YARD, REAR YARD AND BUFFER REQUIREMENTS WITH RESPECT TO THE EXTERIOR BOUNDARIES OF THE SITE.
- F. PURSUANT TO SECTION 1.110 OF THE ORDINANCE AND SECTION 160A-385.1 OF THE NORTH CAROLINA GENERAL STATUTES, THE REZONING PLAN, IF APPROVED, SHALL BE VESTED FOR A PERIOD OF 5 YEARS DUE TO THE SIZE AND PHASING OF THE DEVELOPMENT, THE LEVEL OF INVESTMENT, ECONOMIC CYCLES AND MARKET CONDITIONS.
- G. FUTURE AMENDMENTS TO THE REZONING PLAN AND/OR THESE DEVELOPMENT STANDARDS MAY BE APPLIED FOR BY THE THEN OWNER OR OWNERS OF A DEVELOPMENT AREA WITHOUT THE CONSENT OF THE OWNER OR OWNERS OF ANY OTHER DEVELOPMENT AREA IN ACCORDANCE WITH THE PROVISIONS OF CHAPTER 6 OF THE ORDINANCE. ALTERATIONS TO THE REZONING PLAN ARE SUBJECT TO SECTION 6.207 OF THE ORDINANCE.

**2. PERMITTED USES/DEVELOPMENT LIMITATIONS**

**A. DEVELOPMENT AREA A AND DEVELOPMENT AREA C**

- (1) SUBJECT TO THE LIMITATIONS SET OUT BELOW IN PARAGRAPHS (2) THROUGH (11), THOSE PORTIONS OF THE SITE DESIGNATED AS DEVELOPMENT AREA A AND DEVELOPMENT AREA C ON THE REZONING PLAN MAY BE DEVOTED TO ANY USE OR USES ALLOWED BY RIGHT OR UNDER PRESCRIBED CONDITIONS IN THE CC ZONING DISTRICT (INCLUDING ANY COMBINATION OF SUCH USES) AND TO ANY INCIDENTAL OR ACCESSORY USES ASSOCIATED THEREWITH THAT ARE PERMITTED UNDER THE ORDINANCE IN THE CC ZONING DISTRICT (INCLUDING WITHOUT LIMITATION, OUTDOOR DINING). FOR PURPOSES OF THIS SECTION 2.A OF THE DEVELOPMENT STANDARDS, DEVELOPMENT AREA A AND DEVELOPMENT AREA C ARE HEREINAFTER COLLECTIVELY REFERRED TO AS THE "COMMERCIAL COMPONENT".
- (2) NOTWITHSTANDING THE TERMS OF PARAGRAPH (1) ABOVE, THE USES SET OUT BELOW SHALL BE PROHIBITED ON THE COMMERCIAL COMPONENT.
  - (a) DWELLINGS, DETACHED, DUPLEX, TRIPLEX, QUADRAPLEX, ATTACHED, MULTI-FAMILY AND MIXED-USE BUILDINGS.
  - (b) DWELLINGS, MIXED USE.
  - (c) DWELLINGS, PLANNED MULTI-FAMILY AND ATTACHED DEVELOPMENT, A SINGLE MULTI-FAMILY OR ATTACHED BUILDING ON A LOT WITH MORE THAN 12 UNITS IN A BUILDING.
  - (d) FUNERAL HOMES AND EMBALMING.
  - (e) HOTELS AND MOTELS.
  - (f) LOCKSMITH AND GUNSMITHS.
  - (g) OUTDOOR RECREATION.
  - (h) PET SERVICES INDOOR/OUTDOOR.
- (3) A MAXIMUM OF ONE AUTOMOTIVE SERVICE STATION MAY BE LOCATED ON THE COMMERCIAL COMPONENT.
- (4) A MAXIMUM OF ONE CONVENIENCE STORE WITH OR WITHOUT GASOLINE SALES MAY BE LOCATED ON THE COMMERCIAL COMPONENT. GASOLINE PUMPS, IF PROVIDED, MUST BE LOCATED TO THE REAR OF THE CONVENIENCE STORE BUILDING.
- (5) SUBJECT TO THE TERMS OF PARAGRAPHS (6), (7), (8) AND (9) BELOW, A TOTAL MAXIMUM OF 4 USES LOCATED ON THE COMMERCIAL COMPONENT MAY HAVE DRIVE-IN AND DRIVE-THROUGH SERVICE LANES/WINDOWS AS AN ACCESSORY USE IN ACCORDANCE WITH THE REQUIREMENTS OF SECTION 12.413 OF THE ORDINANCE.
- (6) A MAXIMUM OF 2 EATING, DRINKING AND ENTERTAINMENT ESTABLISHMENTS (TYPE 1 AND/OR TYPE 2) LOCATED ON THE COMMERCIAL COMPONENT MAY HAVE ACCESSORY DRIVE-IN AND DRIVE-THROUGH SERVICE LANES/WINDOWS.
- (7) A MAXIMUM OF 2 OF THE 4 USES ON THE COMMERCIAL COMPONENT THAT MAY HAVE ACCESSORY DRIVE-IN AND DRIVE-THROUGH SERVICE LANES/WINDOWS MAY BE LOCATED ON PROSPERITY CHURCH ROAD.
- (8) A MAXIMUM OF 1 OF THE 2 EATING, DRINKING AND ENTERTAINMENT ESTABLISHMENTS (TYPE 1 AND/OR TYPE 2) ON THE COMMERCIAL COMPONENT THAT MAY HAVE ACCESSORY DRIVE-IN AND DRIVE-THROUGH SERVICE LANES/WINDOWS MAY BE LOCATED ON PROSPERITY CHURCH ROAD.
- (9) IF A USE LOCATED ON THE COMMERCIAL COMPONENT HAS ACCESSORY DRIVE-IN AND DRIVE-THROUGH SERVICE LANES/WINDOWS, THEN NEITHER A MENU BOARD, NOR A SPEAKER BOX, NOR SERVICE WINDOW(S), NOR THE DRIVE-THROUGH VEHICULAR SERVICE LANE MAY BE LOCATED BETWEEN THE USE AND THE ADJACENT PUBLIC STREET.
- (10) A TOTAL MAXIMUM OF 145,000 SQUARE FEET OF GROSS FLOOR AREA MAY BE DEVELOPED ON THE COMMERCIAL COMPONENT, OF WHICH A MAXIMUM OF 125,000 SQUARE FEET OF GROSS FLOOR AREA MAY BE DEVOTED TO RETAIL, SERVICE, CONVENIENCE STORE, INDOOR RECREATION (FITNESS) AND EATING, DRINKING AND ENTERTAINMENT ESTABLISHMENT (TYPE 1 AND/OR TYPE 2) USES.
- (11) PRINCIPAL USE ESTABLISHMENTS WITH AN ACCESSORY DRIVE-IN SERVICE WINDOW AND/OR OUTDOOR SERVICE WINDOW HAVING INDOOR SEATING ACCOMMODATIONS FOR FEWER THAN 50 PATRONS SHALL NOT BE PERMITTED ON THE COMMERCIAL COMPONENT.

**B. DEVELOPMENT AREA B**

- (1) THAT PORTION OF THE SITE DESIGNATED AS DEVELOPMENT AREA B ON THE REZONING PLAN MAY ONLY BE DEVOTED TO A RESIDENTIAL COMMUNITY CONTAINING A MAXIMUM OF 300 MULTI-FAMILY DWELLING UNITS AND TO ANY INCIDENTAL OR ACCESSORY USES ASSOCIATED THEREWITH THAT ARE PERMITTED UNDER THE ORDINANCE IN THE CC ZONING DISTRICT. INCIDENTAL AND ACCESSORY USES MAY INCLUDE, WITHOUT LIMITATION, A LEASING AND MANAGEMENT OFFICE AND AMENITIES SUCH AS A FITNESS CENTER, CLUBHOUSE, SWIMMING POOL, DOG PARK, PLAYGROUND, POCKET PARK AND OUTDOOR GRILLING AND GATHERING AREAS.

**C. DEVELOPMENT AREA D**

- (1) THAT PORTION OF THE SITE DESIGNATED AS DEVELOPMENT AREA D ON THE REZONING PLAN MAY ONLY BE DEVOTED TO A RESIDENTIAL COMMUNITY CONTAINING A MAXIMUM OF 132 SINGLE FAMILY ATTACHED DWELLING UNITS AND TO ANY INCIDENTAL OR ACCESSORY USES ASSOCIATED THEREWITH THAT ARE PERMITTED UNDER THE ORDINANCE IN THE UR-2 ZONING DISTRICT.

**D. DEVELOPMENT AREA E**

- (1) THAT PORTION OF THE SITE DESIGNATED AS DEVELOPMENT AREA E ON THE REZONING PLAN MAY ONLY BE DEVOTED TO THE USES SET OUT BELOW (INCLUDING ANY COMBINATION OF SUCH USES) AND TO ANY INCIDENTAL OR ACCESSORY USES ASSOCIATED THEREWITH THAT ARE PERMITTED UNDER THE ORDINANCE IN THE CC ZONING DISTRICT.
  - (a) OPEN SPACE AREAS (PASSIVE AND ACTIVE).
  - (b) TREE SAVE AREAS.
  - (c) PARKS, GREENWAYS AND TRAILS.
- 3. TRANSPORTATION
  - A. VEHICULAR ACCESS SHALL BE AS GENERALLY DEPICTED ON THE REZONING PLAN. THE PLACEMENT AND CONFIGURATION OF THE ACCESS POINTS ARE SUBJECT TO ANY MINOR MODIFICATIONS REQUIRED BY THE CHARLOTTE DEPARTMENT OF TRANSPORTATION ("CDOT") AND/OR THE NORTH CAROLINA DEPARTMENT OF TRANSPORTATION ("NCDOT").
  - B. THE ALIGNMENTS AND CONFIGURATIONS OF THE INTERNAL PRIVATE STREETS, DRIVES AND ALLEYS AND PARKING AND VEHICULAR CIRCULATION AREAS MAY BE MODIFIED BY PETITIONER TO ACCOMMODATE CHANGES IN TRAFFIC PATTERNS, PARKING LAYOUTS AND ANY ADJUSTMENTS REQUIRED FOR APPROVAL BY CDOT AND/OR NCDOT IN ACCORDANCE WITH APPLICABLE PUBLISHED STANDARDS.
  - C. A MINIMUM 8 FOOT WIDE PLANTING STRIP AND A MINIMUM 6 FOOT WIDE SIDEWALK SHALL BE INSTALLED ALONG THE SITE'S FRONTAGES ON PROSPERITY CHURCH ROAD AND JOHNSTON OEHLER ROAD AS GENERALLY DEPICTED ON THE REZONING PLAN.
  - D. A MINIMUM 8 FOOT WIDE PLANTING STRIP AND A MINIMUM 12 FOOT WIDE MULTI-USE PATH SHALL BE INSTALLED ALONG THE EASTERN SIDE OF PROSPERITY RIDGE ROAD EXTENSION.
  - E. A MINIMUM 8 FOOT WIDE PLANTING STRIP AND A MINIMUM 6 FOOT WIDE SIDEWALK SHALL BE INSTALLED ALONG THE WESTERN SIDE OF PROSPERITY RIDGE ROAD EXTENSION. NOTWITHSTANDING THE FOREGOING, IN THOSE AREAS THAT ARE ADJACENT TO ON-STREET PARKING, A MINIMUM 8 FOOT WIDE SIDEWALK LOCATED BACK OF CURB.
  - F. NOTWITHSTANDING THE TERMS OF PARAGRAPH 3.E ABOVE, AT THE OPTION OF PETITIONER, PETITIONER MAY INSTALL A MINIMUM 8 FOOT WIDE PLANTING STRIP AND A MINIMUM 12 FOOT WIDE MULTI-USE PATH ALONG THE WESTERN SIDE OF PROSPERITY RIDGE ROAD EXTENSION.
  - G. PRIOR TO THE ISSUANCE OF THE FIRST CERTIFICATE OF OCCUPANCY FOR A NEW BUILDING CONSTRUCTED ON THE SITE, PETITIONER SHALL DEDICATE AND CONVEY TO THE CITY OF CHARLOTTE (SUBJECT TO A RESERVATION FOR ANY NECESSARY UTILITY EASEMENTS) THE RIGHT OF WAY NECESSARY TO ACCOMMODATE THE CROSS SECTION FOR THAT PORTION OF PROSPERITY RIDGE ROAD TO BE CONSTRUCTED ON THE SITE BETWEEN JOHNSTON OEHLER ROAD AND PROSPERITY CHURCH ROAD (HEREINAFTER "PROSPERITY RIDGE ROAD EXTENSION"). THE CROSS SECTION FOR PROSPERITY ROAD EXTENSION IS SET OUT ON SHEET RZ-5 OF THE REZONING PLAN.
  - H. SUBJECT TO THE APPROVAL OF CDOT AND ANY OTHER GOVERNMENTAL AGENCIES, PETITIONER SHALL CONSTRUCT AN ADA COMPLIANT BUS WAITING PAD 60.03A WITHIN THE REQUIRED PLANTING STRIP ALONG THE SITE'S FRONTAGE ON PROSPERITY CHURCH ROAD. THE EXACT LOCATION OF THE WAITING PAD SHALL BE DETERMINED DURING THE SITE DESIGN AND PERMITTING PROCESS, AND THE WAITING PAD SHALL BE LOCATED ENTIRELY WITHIN RIGHT OF WAY. IN THE EVENT THAT PETITIONER CANNOT OBTAIN ALL APPROVALS AND PERMITS REQUIRED TO CONSTRUCT THE WAITING PAD, THEN PETITIONER SHALL HAVE NO OBLIGATION TO CONSTRUCT THE WAITING PAD. CATS SHALL BE RESPONSIBLE FOR THE INSTALLATION AND MAINTENANCE OF A BENCH OR SHELTER ON THE WAITING PAD.
  - I. INTERNAL SIDEWALKS AND PEDESTRIAN CONNECTIONS SHALL BE PROVIDED ON THE SITE AS GENERALLY DEPICTED ON THE REZONING PLAN.
  - J. PRIOR TO THE ISSUANCE OF THE FIRST CERTIFICATE OF OCCUPANCY FOR A NEW BUILDING CONSTRUCTED ON THE SITE, PETITIONER SHALL DEDICATE AND CONVEY TO THE CITY OR TO NCDOT (SUBJECT TO A RESERVATION FOR ANY NECESSARY UTILITY EASEMENTS) THOSE PORTIONS OF THE SITE LOCATED IMMEDIATELY ADJACENT TO JOHNSTON OEHLER ROAD AS REQUIRED TO PROVIDE RIGHT OF WAY FROM THE EXISTING CENTERLINE OF JOHNSTON OEHLER ROAD TO THAT POINT THAT IS LOCATED 2 FEET BEHIND THE SIDEWALK WHERE FEASIBLE.
  - K. PRIOR TO THE ISSUANCE OF THE FIRST CERTIFICATE OF OCCUPANCY FOR A NEW BUILDING CONSTRUCTED ON THE SITE, PETITIONER SHALL DEDICATE AND CONVEY TO THE CITY OR TO NCDOT (SUBJECT TO A RESERVATION FOR ANY NECESSARY UTILITY EASEMENTS) THOSE PORTIONS OF THE SITE LOCATED IMMEDIATELY ADJACENT TO PROSPERITY CHURCH ROAD AS REQUIRED TO PROVIDE RIGHT OF WAY FROM THE EXISTING CENTERLINE OF PROSPERITY CHURCH ROAD TO THAT POINT THAT IS LOCATED 2 FEET BEHIND THE SIDEWALK WHERE FEASIBLE.
  - L. ANY REFERENCE TO THE TERM "SUBSTANTIALLY COMPLETE" IN THIS SECTION 3 OF THE DEVELOPMENT STANDARDS SHALL MEAN A DETERMINATION BY CDOT AND/OR NCDOT THAT THE APPLICABLE ROADWAY IMPROVEMENTS ARE DEEMED "SUBSTANTIALLY COMPLETE" FOR THE PURPOSE OF THE ISSUANCE OF CERTIFICATES OF OCCUPANCY FOR BUILDING(S) ON THE SITE. HOWEVER, IN THE EVENT THAT CERTAIN NON-ESSENTIAL ROADWAY IMPROVEMENTS (AS REASONABLY DETERMINED BY CDOT) ARE NOT COMPLETED AT THE TIME THAT PETITIONER SEEKS TO OBTAIN A CERTIFICATE OF OCCUPANCY FOR BUILDING(S) ON THE SITE, THEN CDOT WILL INSTRUCT APPLICABLE AUTHORITIES TO ALLOW THE ISSUANCE OF CERTIFICATES OF OCCUPANCY FOR THE APPLICABLE BUILDINGS, AND IN SUCH EVENT PETITIONER MAY BE REQUIRED TO POST A LETTER OF CREDIT OR A BOND FOR ANY IMPROVEMENTS NOT IN PLACE AT THE TIME SUCH CERTIFICATES OF OCCUPANCY ARE ISSUED TO SECURE THE COMPLETION OF THE RELEVANT IMPROVEMENTS.
  - M. PETITIONER SHALL, AT ITS COST AND EXPENSE, CONSTRUCT PROSPERITY RIDGE ROAD EXTENSION ON THE SITE IN ACCORDANCE WITH APPLICABLE CROSS SECTIONS SET OUT ON SHEET RZ-5 OF THE REZONING PLAN. PROSPERITY RIDGE ROAD EXTENSION SHALL BE SUBSTANTIALLY COMPLETE PRIOR TO THE ISSUANCE OF THE FIRST CERTIFICATE OF OCCUPANCY FOR A NEW BUILDING CONSTRUCTED ON THE SITE.
  - N. THE TRANSPORTATION IMPROVEMENTS SET OUT BELOW SHALL BE SUBSTANTIALLY COMPLETE PRIOR TO THE ISSUANCE OF THE FIRST CERTIFICATE OF OCCUPANCY FOR A NEW BUILDING CONSTRUCTED ON THE SITE.
    - (1) **BENFIELD ROAD AT JOHNSTON OEHLER ROAD/DEARMON ROAD**
      - (a) CONSTRUCT A SOUTHBOUND RIGHT-TURN LANE WITH A MINIMUM OF 300 FEET OF FULL-WIDTH STORAGE AND AN APPROPRIATE TAPER LENGTH.
      - (b) ADD A PERMITTED-OVERLAP SIGNAL PHASE FOR THE SOUTHBOUND RIGHT-TURN MOVEMENT (TO RUN CONCURRENTLY WITH THE EASTBOUND LEFT-TURN MOVEMENT).
      - (c) COORDINATE WITH CDOT ON THE NEED FOR AND FEASIBILITY OF A WESTBOUND RIGHT-TURN LANE WITH A MINIMUM OF 100 FEET OF FULL-WIDTH STORAGE AND ASSOCIATED PERMITTED-OVERLAP SIGNAL PHASE.
      - (d) EXTEND THE EASTBOUND RIGHT-TURN LANE TO 250' OF FULL WIDTH STORAGE.
    - (2) IN LIEU OF IMPROVEMENTS AT THE JOHNSTON OEHLER ROAD AND PROSPERITY RIDGE ROAD ROUNDABOUT, PETITIONER SHALL PAY THE SUM OF \$41,360.00 TO CDOT TO CONTRIBUTE TOWARDS THE COST OF TRANSPORTATION IMPROVEMENTS TO BE INSTALLED BY OTHERS.
  - (3) **PROSPERITY CHURCH ROAD AT SITE ACCESS A**
    - (a) CONSTRUCT A SOUTHBOUND LEFT-TURN LANE WITH A MINIMUM OF 150 FEET OF FULL-WIDTH STORAGE AND AN APPROPRIATE TAPER LENGTH.
  - (4) **PROSPERITY CHURCH ROAD AT PANTHERSVILLE DRIVE/SITE ACCESS B**
    - (a) CONSTRUCT A SOUTHBOUND RIGHT-TURN LANE WITH A MINIMUM OF 100 FEET OF FULL-WIDTH STORAGE AND AN APPROPRIATE TAPER LENGTH.
    - (b) PANTHERSVILLE DRIVE AND ACCESS B SHALL OPERATE AS RIGHT-IN, RIGHT-OUT VEHICULAR ACCESS POINTS.
  - (5) **PROSPERITY CHURCH ROAD AT GUIDEPOST SCHOOL ENTRANCE/SITE ACCESS C**
    - (a) MAINTAIN THE EXISTING SOUTHBOUND LEFT-TURN LANE AT GUIDEPOST SCHOOL ENTRANCE TO FACILITATE ACCESS INTO THE SITE.
  - (6) **PROSPERITY CHURCH ROAD AT SITE ACCESS D/PROSPERITY RIDGE ROAD EXTENSION/STONE PARK DRIVE**
    - (a) INSTALL A TRAFFIC SIGNAL TO RUN IN COORDINATION WITH THE PROSPERITY CHURCH ROAD CORRIDOR; TIMING AND PHASING SHOULD BE DETERMINED BY ADDITIONAL ENGINEERING STUDY.
    - (b) CONSTRUCT A NORTHBOUND RIGHT-TURN LANE ON PROSPERITY CHURCH ROAD WITH A MINIMUM OF 100 FEET OF FULL-WIDTH STORAGE AND AN APPROPRIATE TAPER LENGTH.
    - (c) CONSTRUCT A SOUTHBOUND LEFT-TURN LANE ON PROSPERITY CHURCH ROAD WITH A MINIMUM OF 150 FEET OF FULL-WIDTH STORAGE AND AN APPROPRIATE TAPER LENGTH; COORDINATE WITH CDOT ON THE NEED TO REALLOCATE STORAGE ASSOCIATED WITH THE EXISTING NORTHBOUND LEFT-TURN LANE INTO GUIDEPOST SCHOOL.
    - (d) CONSTRUCT A NORTHBOUND LEFT-TURN LANE WITH A MINIMUM OF 150 FEET OF FULL-WIDTH STORAGE AND AN APPROPRIATE TAPER LENGTH; COORDINATE WITH CDOT ON THE NEED TO REALLOCATE STORAGE ASSOCIATED WITH THE EXISTING SOUTHBOUND LEFT-TURN LANE AT OLD TIMBER ROAD.
  - (7) **PROSPERITY CHURCH ROAD AT OLD TIMBER ROAD**
    - (a) CONSTRUCT AN EASTBOUND RIGHT-TURN LANE WITH APPROPRIATE STORAGE AND TAPER LENGTH AS RIGHT-OF-WAY CONSTRAINTS ALLOW.

- (8) THE TYPICAL CROSS SECTION ON THE PROPOSED PROSPERITY RIDGE ROAD EXTENSION SHOULD CONSIST OF ONE THROUGH LANE IN EACH DIRECTION AND A CENTER TWO-WAY LEFT-TURN LANE. THE FOLLOWING AUXILIARY TURN LANES ARE WARRANTED AT EACH PROPOSED SITE DRIVEWAY:
  - (a) **PROSPERITY RIDGE ROAD EXTENSION AT SITE ACCESS E**
    - (i) CONSTRUCT A NORTHBOUND LEFT-TURN LANE WITH A MINIMUM STORAGE OF 25 FEET.
    - (b) **PROSPERITY RIDGE ROAD EXTENSION AT SITE ACCESS F**
      - (i) CONSTRUCT A NORTHBOUND LEFT-TURN LANE WITH A MINIMUM STORAGE OF 25 FEET.
      - (ii) CONSTRUCT A SOUTHBOUND RIGHT-TURN LANE WITH A MINIMUM STORAGE OF 25 FEET.
  - (c) **PROSPERITY RIDGE ROAD EXTENSION AT SITE ACCESS G**
    - (i) CONSTRUCT A NORTHBOUND LEFT-TURN LANE WITH A MINIMUM STORAGE OF 50 FEET.
    - (ii) CONSTRUCT A SOUTHBOUND RIGHT-TURN LANE WITH A MINIMUM STORAGE OF 50 FEET.
  - (d) **PROSPERITY RIDGE ROAD EXTENSION AT SITE ACCESS H**
    - (i) CONSTRUCT A NORTHBOUND LEFT-TURN LANE WITH A MINIMUM STORAGE OF 25 FEET.
    - (9) **JOHNSTON OEHLER ROAD AT SITE ACCESS I (SINGLE FAMILY ATTACHED DWELLING UNITS ACCESS)**
      - (a) CONSTRUCT A NORTHBOUND RIGHT-TURN LANE WITH A MINIMUM STORAGE OF 100 FEET.
- 4. ARCHITECTURAL AND DESIGN STANDARDS
  - A. **DEVELOPMENT AREA A AND DEVELOPMENT AREA C**
    - (1) THE MAXIMUM HEIGHT OF ANY BUILDING DEVELOPED ON DEVELOPMENT AREA A OR ON DEVELOPMENT AREA C SHALL BE GOVERNED BY THE ORDINANCE.
    - (2) THE ARCHITECTURAL AND DESIGN STANDARDS SET OUT BELOW SHALL APPLY TO DEVELOPMENT AREA A AND DEVELOPMENT AREA C.
      - (a) BUILDING PLACEMENT AND SITE DESIGN SHALL FOCUS ON AND ENHANCE THE PEDESTRIAN ENVIRONMENT ON PUBLIC OR PRIVATE NETWORK REQUIRED STREETS THROUGH THE FOLLOWING:
        - (i) BUILDINGS SHALL BE PLACED SO AS TO PRESENT A FRONT OR SIDE FACADE TO ALL STREETS.
        - (ii) FACADES FRONTING STREETS SHALL INCLUDE A COMBINATION OF WINDOWS AND OPERABLE DOORS FOR A MINIMUM OF 60% OF EACH FRONTAGE ELEVATION WITH TRANSPARENT GLASS BETWEEN 2' AND 10' ON THE FIRST FLOOR. UP TO 20% OF THIS REQUIREMENT MAY BE COMPRISED OF DISPLAY WINDOWS. THESE DISPLAY WINDOWS MUST MAINTAIN A MINIMUM OF 3'-0" CLEAR DEPTH BETWEEN WINDOW AND REAR WALL. WINDOWS WITHIN THIS ZONE SHALL NOT BE SCREENED BY FILM, DECALS, AND OTHER OPAQUE MATERIAL, GLAZING FINISHES OR WINDOW TREATMENTS. THE MAXIMUM SILL HEIGHT FOR REQUIRED TRANSPARENCY SHALL NOT EXCEED 4'-0" ABOVE ADJACENT STREET SIDEWALK.
        - (iii) THE FACADES OF THE FIRST/GROUND FLOOR OF THE BUILDINGS ALONG STREETS SHALL INCORPORATE A MINIMUM OF 30% MASONRY MATERIALS SUCH AS BRICK OR STONE.
        - (iv) A DIRECT PEDESTRIAN CONNECTION SHOULD BE PROVIDED BETWEEN STREET FACING DOORS AND CORNER ENTRANCE FEATURES TO SIDEWALKS ON ADJACENT STREETS.
        - (v) BUILDING ELEVATIONS SHALL NOT HAVE EXPANSES OF BLANK WALLS GREATER THAN 20 FEET IN ALL DIRECTIONS AND ARCHITECTURAL FEATURES SUCH AS, BUT NOT LIMITED TO, BANDING, MEDALLIONS OR DESIGN FEATURES OR MATERIALS WILL BE PROVIDED TO AVOID A STERILE, UNARTICULATED BLANK TREATMENT OF SUCH WALLS.
        - (vi) BUILDING ELEVATIONS SHALL BE DESIGNED WITH VERTICAL BAYS OR ARTICULATED ARCHITECTURAL FEATURES WHICH SHALL INCLUDE A COMBINATION OF AT LEAST THREE OF THE FOLLOWING: A COMBINATION OF EXTERIOR WALL OFFSETS (PROJECTIONS AND RECESSES), COLUMNS, PILASTERS, CHANGE IN MATERIALS OR COLORS, AWNINGS, ARCADES OR OTHER ARCHITECTURAL ELEMENTS.
        - (vii) BUILDINGS SHALL HAVE A MINIMUM HEIGHT OF 22 FEET.
        - (viii) MULTI-STORY BUILDINGS SHALL HAVE A MINIMUM OF 20% TRANSPARENCY ON ALL UPPER STORIES.
    - B. **DEVELOPMENT AREA B**
      - (1) THE MAXIMUM HEIGHT IN STORIES OF ANY BUILDING DEVELOPED ON DEVELOPMENT AREA B SHALL BE 3 STORIES.
      - (2) THE ARCHITECTURAL AND DESIGN STANDARDS SET OUT BELOW SHALL APPLY TO DEVELOPMENT AREA B.
        - (a) PREFERRED EXTERIOR BUILDING MATERIALS: ALL PRINCIPAL AND ACCESSORY BUILDINGS ABUTTING A NETWORK REQUIRED PUBLIC OR PRIVATE STREET SHALL COMPRISE A MINIMUM OF 20% OF THAT BUILDING'S ENTIRE FAÇADE FACING SUCH NETWORK STREET USING BRICK, NATURAL STONE (OR ITS SYNTHETIC EQUIVALENT), STUCCO OR OTHER MATERIAL APPROVED BY THE PLANNING DIRECTOR.
          - (b) PROHIBITED EXTERIOR BUILDING MATERIALS:
            - (i) VINYL SIDING (BUT NOT VINYL HAND RAILS, WINDOWS, DOORS OR DOOR TRIM).
            - (ii) CONCRETE MASONRY UNITS NOT ARCHITECTURALLY FINISHED.
          - (c) BUILDING PLACEMENT AND SITE DESIGN SHALL FOCUS ON AND ENHANCE THE PEDESTRIAN ENVIRONMENT THROUGH THE FOLLOWING:
            - (i) BUILDINGS SHALL BE PLACED SO AS TO PRESENT A FRONT OR SIDE FACADE TO ALL NETWORK REQUIRED STREETS (PUBLIC OR PRIVATE).
            - (ii) BUILDINGS SHALL FRONT A MINIMUM OF 50% OF THE TOTAL NETWORK REQUIRED STREET FRONTAGE ON DEVELOPMENT AREA B (EXCLUSIVE OF DRIVEWAYS, PEDESTRIAN ACCESS POINTS, ACCESSIBLE OPEN SPACE).
            - (iii) PARKING LOTS SHALL NOT BE LOCATED BETWEEN ANY BUILDING AND ANY NETWORK REQUIRED PUBLIC OR PRIVATE STREET.
            - (iv) DRIVEWAYS INTENDED TO SERVE SINGLE UNITS SHALL BE PROHIBITED ON ALL NETWORK REQUIRED STREETS.
            - (d) BUILDING MASSING AND HEIGHT SHALL BE DESIGNED TO BREAK UP LONG MONOLITHIC BUILDING FORMS AS FOLLOWS:
              - (i) BUILDINGS EXCEEDING 120 FEET IN LENGTH SHALL INCLUDE MODULATIONS OF THE BUILDING MASSING/FACADE PLANE (SUCH AS RECESSES, PROJECTIONS, AND ARCHITECTURAL DETAILS). MODULATIONS SHALL BE A MINIMUM OF 10 FEET WIDE AND SHALL PROJECT OR RECESS A MINIMUM OF 6 FEET EXTENDING THROUGH THE BUILDING.
              - (e) ARCHITECTURAL ELEVATION DESIGN – ELEVATIONS SHALL BE DESIGNED TO CREATE VISUAL INTEREST AS FOLLOWS:
                - (i) BUILDING ELEVATIONS SHALL BE DESIGNED WITH VERTICAL BAYS OR ARTICULATED ARCHITECTURAL FACADE FEATURES WHICH MAY INCLUDE BUT NOT BE LIMITED TO A COMBINATION OF EXTERIOR WALL OFFSETS, PROJECTIONS, RECESSES, PILASTERS, BANDING AND CHANGE IN MATERIALS OR COLORS.
                - (ii) BUILDINGS SHALL BE DESIGNED WITH A RECOGNIZABLE ARCHITECTURAL BASE ON ALL FACADES FACING NETWORK REQUIRED PUBLIC OR PRIVATE STREETS. SUCH BASE MAY BE EXECUTED THROUGH USE OF PREFERRED EXTERIOR BUILDING MATERIALS OR ARTICULATED ARCHITECTURAL FACADE FEATURES AND COLOR CHANGES.
                - (iii) BUILDING ELEVATIONS FACING NETWORK REQUIRED PUBLIC OR PRIVATE STREETS SHALL NOT HAVE EXPANSES OF BLANK WALLS GREATER THAN 20 FEET IN ALL DIRECTIONS AND ARCHITECTURAL FEATURES SUCH AS BUT NOT LIMITED TO BANDING, MEDALLIONS OR DESIGN FEATURES OR MATERIALS WILL BE PROVIDED TO AVOID A STERILE, UNARTICULATED BLANK TREATMENT OF SUCH WALLS.
                - (f) ROOF FORM AND ARTICULATION – ROOF FORM AND LINES SHALL BE DESIGNED TO AVOID THE APPEARANCE OF A LARGE MONOLITHIC ROOF STRUCTURE AS FOLLOWS:
                  - (i) LONG PITCHED OR FLAT ROOF LINES SHALL AVOID CONTINUOUS EXPANSES WITHOUT VARIATION BY INCLUDING CHANGES IN HEIGHT AND/OR ROOF FORM, TO INCLUDE BUT NOT BE LIMITED TO GABLES, HIPPS, DORMERS OR PARAPETS.
                  - (ii) FOR PITCHED ROOFS THE MINIMUM ALLOWED IS 4:12 EXCLUDING BUILDINGS WITH A FLAT ROOF AND PARAPET WALLS.
                  - (iii) ROOF TOP HVAC AND RELATED MECHANICAL EQUIPMENT WILL BE SCREENED FROM PUBLIC VIEW AT GRADE FROM THE NEAREST STREET.
                - (g) SERVICE AREA SCREENING – SERVICE AREAS SUCH AS DUMPSTERS, REFUSE AREAS, RECYCLING AND STORAGE SHALL BE SCREENED IN ACCORDANCE WITH THE APPLICABLE REQUIREMENTS OF CHAPTER 12 OF THE ORDINANCE.

|   |  |                      |  |                   |          |                                |      |
|---|--|----------------------|--|-------------------|----------|--------------------------------|------|
| KHA PROJECT                                 |  | KIMLEY-HORN          |  | DATE              | NO.      | REVISIONS                      | DATE |
| 013187000                                   |  | 05/15/2020           |  | SCALE             | AS SHOWN |                                |      |
| DESIGNED BY                                 |  | DRAWN BY             |  | CHECKED BY        |          | REZONING PETITION NO. 2020-088 |      |
| SITE NOTES                                  |  | CITY OF CHARLOTTE    |  | NC                |          |                                |      |
| PCR MIXED USE<br>PREPARED FOR<br>WSB RETAIL |  | SHEET NUMBER<br>RZ-4 |  | CITY OF CHARLOTTE |          |                                |      |



This document, together with the concepts and designs presented herein, as an instrument of service, is intended only for the specific purpose and client for which it was prepared. Reuse of and improper reliance on this document without written authorization and adaptation by Kimley-Horn and Associates, Inc. shall be without liability to Kimley-Horn and Associates, Inc.

C. DEVELOPMENT AREA D

- (1) THE ARCHITECTURAL AND DESIGN STANDARDS SET OUT BELOW SHALL APPLY TO DEVELOPMENT AREA D.
(a) THE PRIMARY EXTERIOR BUILDING MATERIALS FOR THE SINGLE FAMILY ATTACHED DWELLING UNITS TO BE DEVELOPED ON DEVELOPMENT AREA D WILL BE A COMBINATION OF PORTIONS OF THE FOLLOWING: BRICK VENEER OR SIMILAR MASONRY PRODUCTS, STONE, MANUFACTURED STONE, STUCCO AND CEMENTITIOUS SIDING.
(b) VINYL, EIFS OR MASONITE MAY NOT BE USED AS AN EXTERIOR BUILDING MATERIAL ON SINGLE FAMILY ATTACHED DWELLING UNITS DEVELOPED ON DEVELOPMENT AREA D. NOTWITHSTANDING THE FOREGOING, VINYL MAY BE UTILIZED ON WINDOWS, DOORS, GARAGE DOORS, SOFFITS, TRIM AND RAILINGS.
(c) THE ACTUAL WIDTHS OF THE SINGLE FAMILY ATTACHED DWELLING UNITS TO BE DEVELOPED ON DEVELOPMENT AREA D MAY VARY FROM THE WIDTHS DEPICTED ON THE REZONING PLAN.
(d) PITCHED ROOFS, IF PROVIDED, SHALL BE SYMMETRICALLY SLOPED NO LESS THAN 5:12, EXCEPT THAT ROOFS FOR PORCHES AND ATTACHED SHEDS MAY BE NO LESS THAN 2:12, UNLESS A FLAT ROOF ARCHITECTURAL STYLE IS EMPLOYED.
(e) EACH SINGLE FAMILY ATTACHED DWELLING UNIT SHALL HAVE A COVERED FRONT STOOP. THE FRONT STOOP MAY BE COVERED BY AN AWNING, CANOPY, ROOF EXTENSION OR OTHER ARCHITECTURAL FEATURE CHOSEN BY PETITIONER.
(f) ALL CORNER OR END SINGLE FAMILY ATTACHED DWELLING UNITS THAT FACE A PUBLIC OR PRIVATE STREET SHALL HAVE A PORCH OR STOOP THAT WRAPS A PORTION OF THE FRONT AND SIDE OF THE UNIT OR PROVIDE BLANK WALL PROVISIONS THAT LIMIT THE MAXIMUM BLANK WALL EXPANSE TO 10 FEET ON ALL BUILDING LEVELS.
(g) TO PROVIDE PRIVACY, ALL RESIDENTIAL ENTRANCES WITHIN 15 FEET OF THE SIDEWALK LOCATED ALONG DEVELOPMENT AREA D'S FRONTAGE ON PROSPERITY RIDGE ROAD EXTENSION OR DEVELOPMENT AREA D'S FRONTAGE ON JOHNSTON OEHLER ROAD MUST BE RAISED FROM THE AVERAGE SIDEWALK GRADE A MINIMUM OF 12 INCHES.
(h) WALKWAYS SHALL BE PROVIDED TO CONNECT ALL RESIDENTIAL ENTRANCES TO SIDEWALKS ALONG PUBLIC AND PRIVATE STREETS.
(i) EACH SINGLE FAMILY ATTACHED DWELLING UNIT SHALL HAVE A GARAGE.
(j) THE SINGLE FAMILY ATTACHED DWELLING UNITS THAT FRONT PROSPERITY RIDGE ROAD EXTENSION OR JOHNSTON OEHLER ROAD SHALL BE ALLEY LOADED DWELLING UNITS. THIS REQUIREMENT SHALL NOT APPLY TO A SINGLE FAMILY ATTACHED DWELLING UNIT THAT HAS A SIDE FACADE THAT IS ADJACENT TO PROSPERITY RIDGE ROAD EXTENSION OR JOHNSTON OEHLER ROAD. EXCEPT AS PROVIDED ABOVE, ALL SINGLE FAMILY ATTACHED DWELLING UNITS ON DEVELOPMENT AREA D MAY BE FRONT LOADED OR ALLEY LOADED DWELLING UNITS.
(k) BUILDINGS THAT ARE ADJACENT TO AND FRONT A PUBLIC STREET SHALL NOT CONTAIN MORE THAN 5 INDIVIDUAL SINGLE FAMILY ATTACHED DWELLING UNITS. THIS REQUIREMENT SHALL NOT APPLY TO BUILDINGS THAT ARE ADJACENT TO AND FRONT A PRIVATE ALLEY, PRIVATE STREET OR PRIVATE DRIVE OR BUILDINGS THAT ARE ADJACENT AND PERPENDICULAR TO A PUBLIC STREET.

D. DESIGN STANDARDS APPLICABLE TO THE ENTIRE SITE

- (1) THE MINIMUM BUILDING AND PARKING SETBACK SHALL BE 14 FEET FROM THE BACK OF CURB (EXISTING OR PROPOSED). IF THE RIGHT OF WAY IS GREATER THAN THE MINIMUM SETBACK FROM THE BACK OF CURB, THE RIGHT OF WAY LINE WILL BECOME THE MINIMUM SETBACK.
(2) NO SURFACE PARKING OR MANEUVERING SPACE SHALL BE LOCATED BETWEEN ANY BUILDING LINE AND THE STREET, EXCEPT THAT DRIVEWAYS PROVIDING ACCESS TO THE PARKING AREA MAY BE INSTALLED ACROSS THESE AREAS. IT IS THE INTENT THAT THESE DRIVEWAYS BE AS NEARLY PERPENDICULAR TO THE STREET RIGHT OF WAY AS POSSIBLE.
(3) PARKING AREAS MUST REMAIN BEHIND THE ESTABLISHED BUILDING SETBACK.
(4) NO SERVICE OR LOADING AREAS MAY BE ORIENTED TOWARDS THE STREET OR WITHIN THE AREA BETWEEN ANY BUILDING LINE AND THE STREET.

5. STREETScape/BUFFERS

- A. BUFFERS SHALL BE ESTABLISHED ON THE SITE AS REQUIRED BY THE ORDINANCE AND AS DEPICTED ON THE REZONING PLAN, AND SUCH BUFFERS SHALL CONFORM TO THE STANDARDS OF SECTION 12.302 OF THE ORDINANCE. PURSUANT TO THE ORDINANCE, PETITIONER MAY REDUCE THE REQUIRED WIDTH OF A BUFFER BY 25% BY INSTALLING A WALL, FENCE OR BERM THAT MEETS THE STANDARDS OF SECTION 12.302(B) OF THE ORDINANCE.
B. IN THE EVENT THAT AN ADJACENT PARCEL OF LAND IS EITHER REZONED TO A ZONING DISTRICT OR DEVOTED TO A USE THAT ELIMINATES OR REDUCES THE BUFFER REQUIREMENTS ON THE SITE, PETITIONER MAY REDUCE OR ELIMINATE, AS THE CASE MAY BE, THE RELEVANT BUFFER AREAS ACCORDINGLY.
C. PURSUANT TO SECTION 11.405(5) OF THE ORDINANCE, INTERIOR BUFFERS BETWEEN USES LOCATED ON THE SITE ARE WAIVED AND SHALL NOT BE REQUIRED.

D. PETITIONER SHALL INSTALL A MINIMUM 6 FOOT TALL, SOLID WOODEN FENCE ALONG THAT PORTION OF THE SITE'S EASTERN BOUNDARY LINE LOCATED IN DEVELOPMENT AREA E SOUTH OF THE DUKE ENERGY EASEMENT THAT IS GENERALLY DEPICTED ON THE REZONING PLAN. THIS FENCE MAY MEANDER TO SAVE EXISTING TREES AND TO ACCOMMODATE TOPOGRAPHY. THIS FENCE MAY BE REMOVED BY PETITIONER IF THE FENCE IS ULTIMATELY LOCATED ON THE PARK SITE (AS DEFINED BELOW) AND THE REMOVAL OF THE FENCE IS REQUIRED BY MECKLENBURG COUNTY.

E. PETITIONER SHALL INSTALL A MINIMUM 6 FOOT TALL, SOLID WOODEN FENCE ALONG THE EASTERN BOUNDARY LINE OF DEVELOPMENT AREA D AS GENERALLY DEPICTED ON THE REZONING PLAN. THIS FENCE MAY MEANDER TO SAVE EXISTING TREES AND TO ACCOMMODATE TOPOGRAPHY.
F. PETITIONER SHALL INSTALL ENHANCED LANDSCAPING IN THE FORM OF SHRUBS ON EACH SIDE OF THE ACCESS DRIVEWAY INTO THE SITE ON PROSPERITY CHURCH ROAD ACROSS FROM PANTHERSVILLE DRIVE. THIS ENHANCED LANDSCAPING AREA SHALL BE LOCATED BEHIND THE BACK OF SIDEWALK AND OUTSIDE OF THE RIGHT OF WAY AND IT SHALL HAVE A MINIMUM DEPTH OF 8 FEET AND A MINIMUM LENGTH ON EACH SIDE OF THE ACCESS DRIVEWAY OF 50 FEET. THE ENHANCED LANDSCAPING AREA IS GENERALLY DEPICTED ON THE REZONING PLAN. SHRUBS SHALL NOT BE PLANTED IN THE SIGHT DISTANCE TRIANGLES.

6. ENVIRONMENTAL FEATURES

- A. DEVELOPMENT OF THE SITE SHALL COMPLY WITH THE REQUIREMENTS OF THE CITY OF CHARLOTTE TREE ORDINANCE (THE "TREE ORDINANCE").
B. AS NOTED ABOVE IN PARAGRAPH 1.E., THE DEVELOPMENT OF THE SITE SHALL BE CONSIDERED TO BE A PLANNED/UNIFIED DEVELOPMENT. ACCORDINGLY, THE TREE SAVE REQUIREMENTS OF THE TREE ORDINANCE SHALL BE CALCULATED AND SATISFIED OVER THE ENTIRE SITE, RATHER THAN WITHIN EACH INDIVIDUAL DEVELOPMENT AREA. AS A RESULT, EACH INDIVIDUAL DEVELOPMENT AREA SHALL NOT BE REQUIRED TO MEET THE TREE SAVE REQUIREMENTS OF THE TREE ORDINANCE PROVIDED THAT THE SITE AS A WHOLE MEETS SUCH TREE SAVE REQUIREMENTS. NOTWITHSTANDING THE FOREGOING, THE AREA OF THE SITE LOCATED WITHIN THE DUKE ENERGY EASEMENT AND THE AREA OF THE SITE LOCATED WITHIN THE TO BE DEDICATED RIGHT OF WAY FOR PROSPERITY RIDGE ROAD EXTENSION SHALL NOT BE CONSIDERED TO BE PART OF THE SITE WHEN CALCULATING THE REQUIRED TREE SAVE AREA FOR THE SITE.
C. THE TREE SAVE AREAS DEPICTED ON THE REZONING PLAN ARE CONCEPTUAL AND THE ACTUAL TREE SAVE AREAS PROVIDED ON THE SITE MAY DIFFER FROM WHAT IS DEPICTED ON THE REZONING PLAN PROVIDED THAT THE SITE COMPLIES WITH THE REQUIREMENTS OF THE TREE ORDINANCE.
D. PETITIONER ACKNOWLEDGES THAT THE PARKING AREAS LOCATED WITHIN THE DUKE ENERGY EASEMENT SHALL BE REQUIRED TO MEET THE REQUIREMENTS OF THE CITY OF CHARLOTTE TREE ORDINANCE AND THE REQUIREMENTS OF DUKE ENERGY. AS A RESULT, THE FINAL DESIGN OF THESE PARKING AREAS SHALL BE DETERMINED DURING THE PERMITTING PROCESS AND MAY VARY FROM WHAT IS DEPICTED ON THE REZONING PLAN.
E. THE SITE SHALL COMPLY WITH THE REQUIREMENTS OF THE POST CONSTRUCTION CONTROLS ORDINANCE.
F. THE LOCATION, SIZE AND TYPE OF STORM WATER MANAGEMENT SYSTEMS DEPICTED ON THE REZONING PLAN ARE SUBJECT TO REVIEW AND APPROVAL AS PART OF THE FULL DEVELOPMENT PLAN SUBMITTAL AND ARE NOT IMPLICITLY APPROVED WITH THIS REZONING. ADJUSTMENTS MAY BE NECESSARY IN ORDER TO ACCOMMODATE ACTUAL STORM WATER TREATMENT REQUIREMENTS AND NATURAL SITE DISCHARGE POINTS.

7. PARK SITE

A. PRIOR TO THE ISSUANCE OF THE CERTIFICATE OF OCCUPANCY FOR THE SIXTH NEW BUILDING CONSTRUCTED ON THE SITE AND SUBJECT TO THE APPROVAL OF MECKLENBURG COUNTY, PETITIONER SHALL CONVEY A MINIMUM 2 ACRE PORTION OF DEVELOPMENT AREA E (THE "PARK SITE") TO MECKLENBURG COUNTY FOR A FUTURE PASSIVE PUBLIC PARK (THE "PUBLIC PARK"). THE SITE'S STORM WATER DETENTION PONDS SHALL NOT BE LOCATED WITHIN THE PARK SITE. PRIOR TO THE CONVEYANCE OF THE PARK SITE TO MECKLENBURG COUNTY, PETITIONER SHALL HAVE THE RIGHT TO INSTALL AND LOCATE A STORM WATER PIPE OR PIPES THROUGH THE PARK SITE AND TO RESERVE SUCH EASEMENTS OVER THE PARK SITE THAT ARE NECESSARY TO MAINTAIN, REPAIR AND REPLACE SUCH STORM WATER PIPE OR PIPES.

- B. THE PUBLIC PARK SHALL BE A PASSIVE PARK.
C. THE PARK SITE SHALL COUNT TOWARDS THE SITE'S MINIMUM TREE SAVE REQUIREMENTS.
D. THE PARK SITE SHALL COUNT TOWARDS THE SITE'S REQUIRED OPEN SPACE.
E. IN THE EVENT THAT MECKLENBURG COUNTY DOES NOT APPROVE AND ACCEPT THE CONVEYANCE OF THE PARK SITE, THEN THE PARK SITE SHALL BE A PART OF THE SITE'S TREE SAVE AND OPEN SPACE AREA, AND THE PARK SITE SHALL BE OWNED AND MAINTAINED BY THE DEVELOPER OR A PROPERTY OWNERS ASSOCIATION.
B. LIGHTING

- A. ALL FREESTANDING LIGHTING FIXTURES INSTALLED ON THE SITE (EXCLUDING STREET LIGHTS AND LOWER, DECORATIVE LIGHTING THAT MAY BE INSTALLED ALONG THE DRIVEWAYS, SIDEWALKS AND PARKING AREAS AND IN THE LANDSCAPED AREAS) SHALL BE FULLY CAPPED AND SHIELDED AND THE ILLUMINATION DOWNWARDLY DIRECTED SO THAT DIRECT ILLUMINATION DOES NOT EXTEND PAST ANY PROPERTY LINE OF THE SITE.

9. OPEN SPACE/AMENITY AREAS

- A. AN URBAN OPEN SPACE AREA SHALL BE LOCATED ON THE SITE ON THE CORNER OF THE INTERSECTION OF PROSPERITY CHURCH ROAD AND PROSPERITY RIDGE ROAD EXTENSION AS GENERALLY DEPICTED ON THE REZONING PLAN. THIS URBAN OPEN SPACE AREA SHALL HAVE A MINIMUM SIZE OF 6,000 SQUARE FEET AND IT SHALL CONTAIN, AT A MINIMUM, LANDSCAPING, HARDSCAPE AND SEATING ELEMENTS.
B. AN AMENITY AREA SHALL BE PROVIDED ON DEVELOPMENT AREA B AND AT A MINIMUM, THE AMENITY AREA SHALL CONTAIN A CLUBHOUSE WITH A FITNESS CENTER AND A SWIMMING POOL.
C. THE MINIMUM 15,000 SQUARE FOOT URBAN OPEN SPACE ON DEVELOPMENT AREA B SHALL CONTAIN, AT A MINIMUM, PEDESTRIAN WALKWAYS, LANDSCAPING AND SEATING.
D. THE MINIMUM SIZE OF THE CENTRAL GREEN/URBAN OPEN SPACE ON DEVELOPMENT AREA D SHALL BE 18,000 SQUARE FEET AND THE CENTRAL GREEN/OPEN SPACE SHALL CONTAIN, AT A MINIMUM, PEDESTRIAN WALKWAYS, LANDSCAPING AND SEATING.
1. BINDING EFFECT OF THE REZONING DOCUMENTS AND DEFINITIONS
A. IF THIS REZONING PETITION IS APPROVED, ALL CONDITIONS APPLICABLE TO THE USE AND DEVELOPMENT OF THE SITE IMPOSED UNDER THESE DEVELOPMENT STANDARDS AND THE REZONING PLAN WILL, UNLESS AMENDED IN THE MANNER PROVIDED UNDER THE ORDINANCE, BE BINDING UPON AND INURE TO THE BENEFIT OF PETITIONER AND THE CURRENT AND SUBSEQUENT OWNERS OF THE SITE AND THEIR RESPECTIVE SUCCESSORS IN INTEREST AND ASSIGNS.
B. THROUGHOUT THESE DEVELOPMENT STANDARDS, THE TERM "PETITIONER" SHALL BE DEEMED TO INCLUDE THE HEIRS, DEVISEES, PERSONAL REPRESENTATIVES, SUCCESSORS IN INTEREST AND ASSIGNS OF PETITIONER OR THE OWNER OR OWNERS OF THE SITE FROM TIME TO TIME WHO MAY BE INVOLVED IN ANY FUTURE DEVELOPMENT THEREOF.
C. ANY REFERENCE TO THE ORDINANCE HEREIN SHALL BE DEEMED TO REFER TO THE REQUIREMENTS OF THE ORDINANCE IN EFFECT AS OF THE DATE THIS REZONING PETITION IS APPROVED.

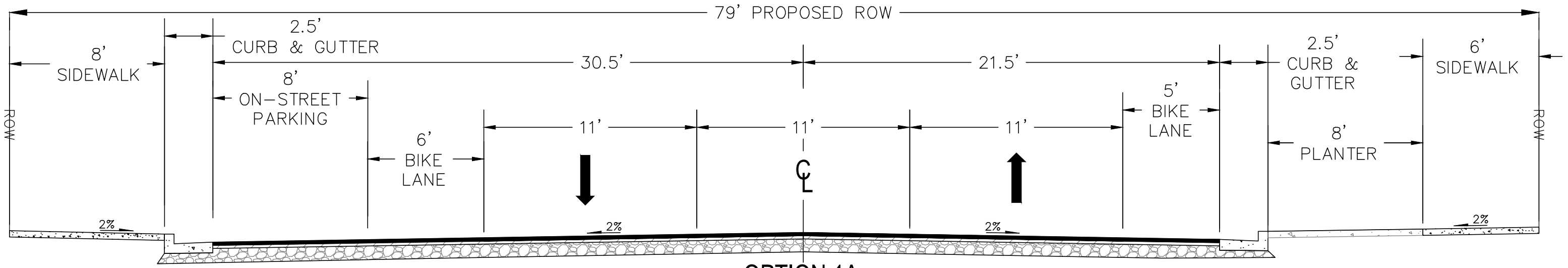

OPTION 1A: PROSPERITY RIDGE ROAD EXTENSION SECTION WITH BICYCLE LANES (SHOWN WITH ON STREET PARKING WHERE APPLICABLE)

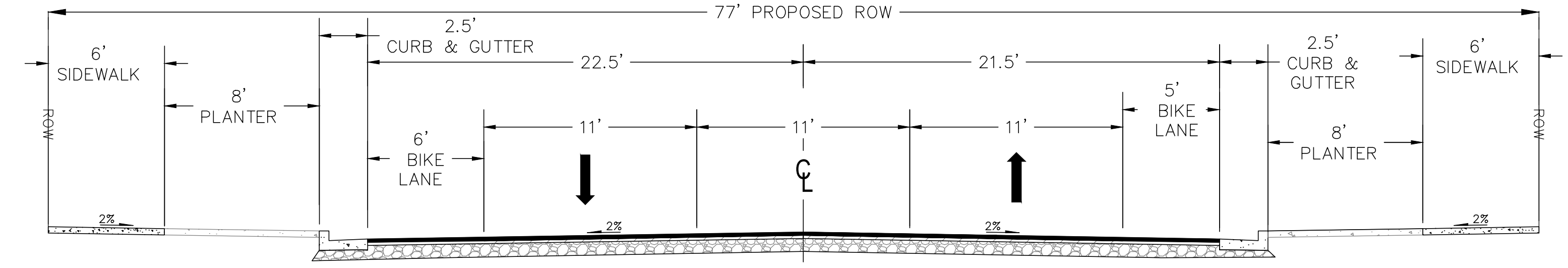

OPTION 1B: PROSPERITY RIDGE ROAD EXTENSION SECTION WITH BICYCLE LANES (WITHOUT ON STREET PARKING)

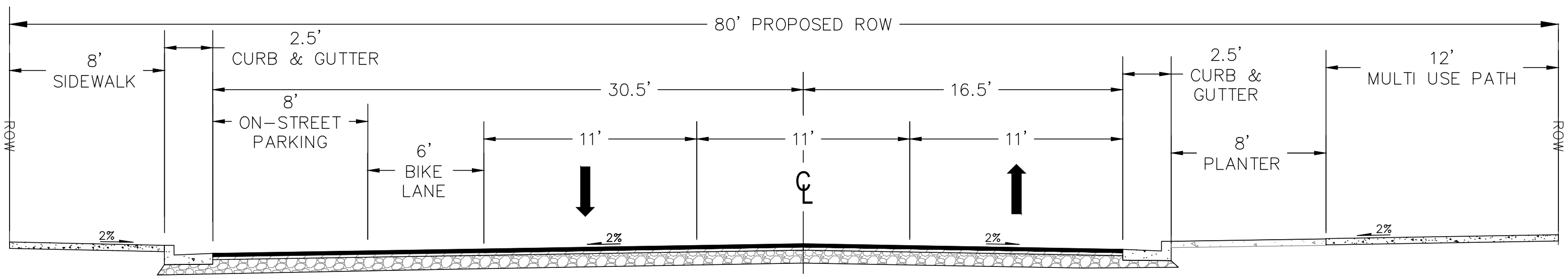

OPTION 2A: PROSPERITY RIDGE ROAD EXTENSION SECTION WITH MULTI-USE PATH (SHOWN WITH ON STREET PARKING WHERE APPLICABLE)

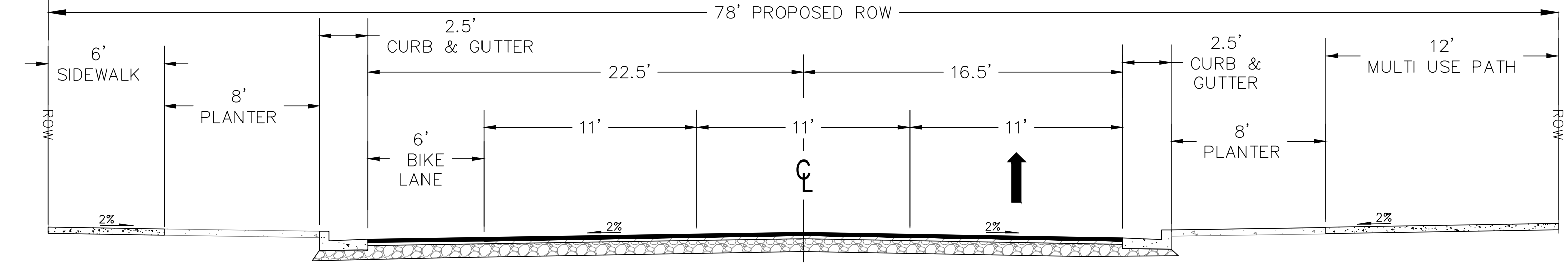

OPTION 2B: PROSPERITY RIDGE ROAD EXTENSION SECTION WITH MULTI-USE PATH (WITHOUT ON STREET PARKING)

| NO. | REVISIONS | DATE | BY |
|-----|-----------|------|----|
|     |           |      |    |
|     |           |      |    |
|     |           |      |    |
|     |           |      |    |

**Kimley»Horn**  
© 2020 KIMLEY-HORN AND ASSOCIATES, INC.  
200 SOUTH TRYON, SUITE 200, CHARLOTTE, NC 28202  
PHONE: 704-333-5131  
WWW.KIMLEY-HORN.COM

|             |            |
|-------------|------------|
| KHA PROJECT | 013187000  |
| DATE        | 05/15/2020 |
| SCALE       | AS SHOWN   |
| DESIGNED BY |            |
| DRAWN BY    |            |
| CHECKED BY  |            |

**SITE NOTES**  
REZONING PETITION NO. 2020-088  
NC

**PCR MIXED USE  
PREPARED FOR  
WSB RETAIL**  
CITY OF CHARLOTTE



Plotted By: Houston, Justin Sheet: WSB Retail Layout: RZ-5 PROPOSED ZONING MAP December 28, 2020 02:20:33pm K:\CHL\PRJ\013187 - wsb\_retail\000 pcr\_mixed\_use\02 - DWG\plan\000 pcr\_mixed\_use.dwg  
 This document, together with the concepts and designs presented herein, is intended only for the specific purpose and client for which it was prepared. Reuse of and improper reliance on this document without written authorization and adaptation by Kimley-Horn and Associates, Inc. shall be without liability to Kimley-Horn and Associates, Inc.

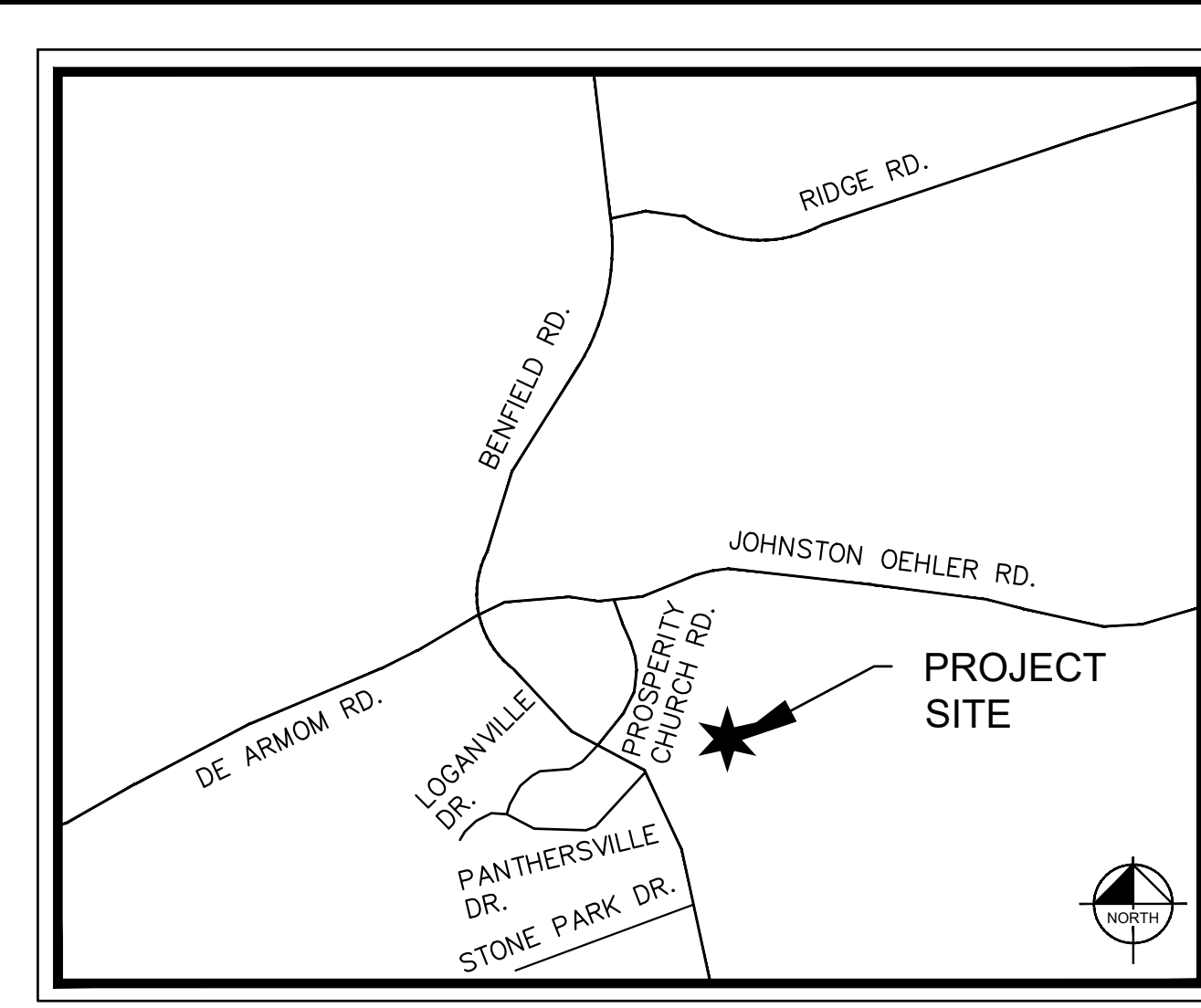
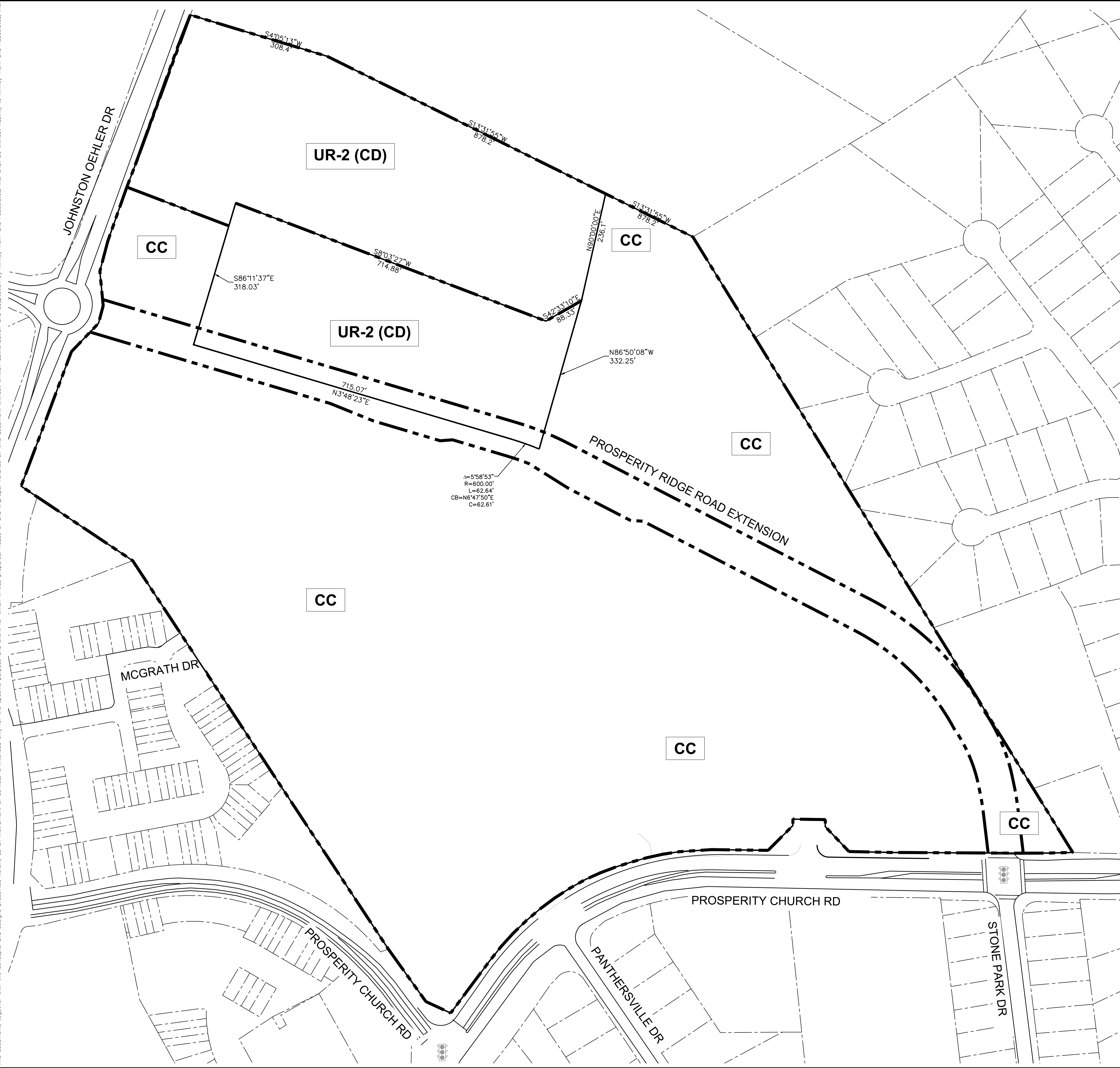

VICINITY MAP  
NOT TO SCALE

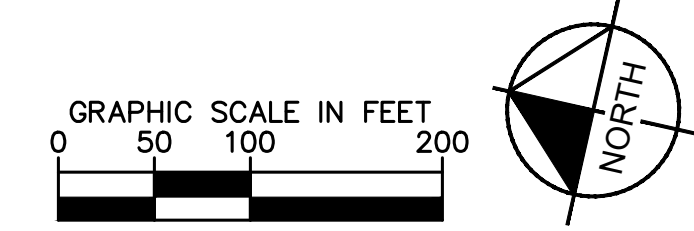

| No. | REVISIONS | DATE | BY |
|-----|-----------|------|----|
|     |           |      |    |
|     |           |      |    |
|     |           |      |    |
|     |           |      |    |

**Kimley»Horn**  
 © 2020 KIMLEY-HORN AND ASSOCIATES, INC.  
 200 SOUTH TRYON, SUITE 200, CHARLOTTE, NC 28202  
 PHONE: 704-333-5131  
 WWW.KIMLEY-HORN.COM

|             |            |
|-------------|------------|
| KHA PROJECT | 013187000  |
| DATE        | 05/15/2020 |
| SCALE       | AS SHOWN   |
| DESIGNED BY |            |
| DRAWN BY    |            |
| CHECKED BY  |            |

**PROPOSED ZONING  
KEY MAP**

PCR MIXED USE  
 PREPARED FOR  
 WSB RETAIL

CITY OF CHARLOTTE NC  
 REZONING PETITION NO. 2020-088

SHEET NUMBER  
**RZ-6**