

PLAN VIEW

NOTES:

1. ELEVATION CONTROL POINTS SHALL BE DESIGNATED AT THE UPSTREAM INVERT (CENTER) OF THE CROSS VANE TO ESTABLISH PART OF THE PROFILE. POOL ELEVATION CONTROL POINTS OR EXCAVATION TO A SPECIFIED MAXIMUM POOL DEPTH SHALL BE DESIGNATED TO ESTABLISH THE REMAINING PROFILE. SURVEY OF CONTROL POINTS SHALL BE REQUIRED TO ESTABLISH ACCURATE CROSS VANE INSTALLATION WITHIN THE TOLERANCE SPECIFIED BY THE DESIGNER.
2. A FOOTER BOULDER IS REQUIRED IF BOULDER DEPTH IS LESS THAN DESIGN POOL DEPTH.
3. BOULDERS SHOULD HAVE 2' MIN. DEPTH.
4. DEEPEST PART OF POOL TO BE IN LINE WITH WHERE VANE ARM TIES INTO THE BANK.
5. POOL DEPTH SHOULD BE ACCORDING TO PROFILE.
6. LOGS SHOULD BE 8"-12" DIAMETER.
7. COMPACTED BRUSH LAYER TO BE INSTALLED BELOW AND PERPENDICULAR TO LOG, AT A THICKNESS OF 1'-2'.

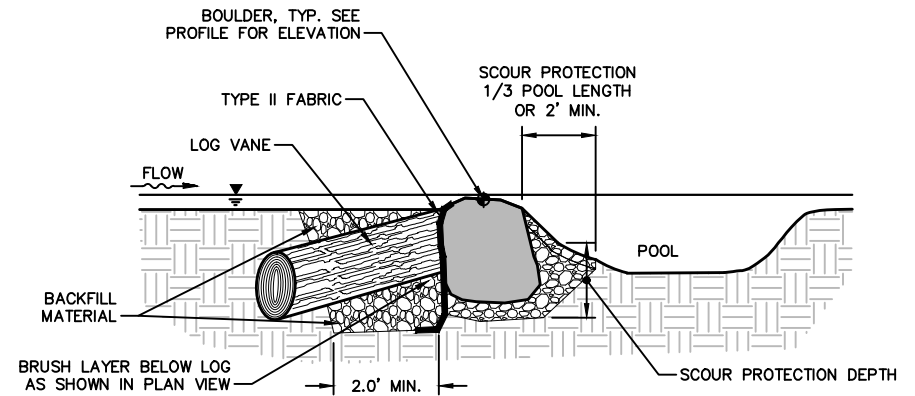

SECTION A-A

DESIGN VARIABLES

	EXAMPLE	REACH	REACH
BOULDER DIMENSIONS	1'x2'x2'	--	--
BACKFILL AND SCOUR PROTECTION MATERIAL <sup>1</sup>	B, 57, E	--	--
BOULDER AND BACKFILL DEPTH	2'	--	--
SCOUR PROTECTION DEPTH	12"	--	--
EMBEDDED LENGTH INTO BANK	3'	--	--
EMBEDDED LENGTH INTO CHANNEL	3'	--	--
VANE SLOPE <sup>2</sup>	3%	--	--
VANE LENGTH	7'	--	--
VANE ANGLE	25°	--	--
HEIGHT ABOVE HEADER	0.21'	--	--
MAX. DROP OVER HEADER <sup>3</sup>	0.1'	--	--

<sup>1</sup> WELL MIXED GRADATION (APPROXIMATELY 80% STONE, 20% EARTH) STONE MIX TO BE COMPRISED OF THE SPECIFIED MATERIALS: A = CLASS A RIP-RAP, B = CLASS B RIP-RAP, 57 = #57 STONE E = EARTH. #57 STONE NOT TO EXCEED 10% OF THE STONE MIX. THE REMAINDER OF THE MIX SHALL BE EQUAL PARTS CLASS A AND CLASS B RIP-RAP IF BOTH ARE SPECIFIED OR AS DIRECTED BY THE ENGINEER.

<sup>2</sup> SLOPE MEASURE FROM HEADER ELEVATION OVER VANE LENGTH WHERE IT INTERSECTS THE BANK. NOT TO EXCEED 5%.

<sup>3</sup> TYPICAL 0.1' - 0.2', NOT TO EXCEED 0.4' BASED ON HEAD OF DOWNSTREAM GRADE CONTROL.

\*ENGINEER TO ADJUST AS NECESSARY, MINIMUMS CANNOT BE ADJUSTED WITHOUT CITY APPROVAL

NOT TO SCALE



CHARLOTTE-MECKLENBURG  
STORM WATER SERVICES  
GENERIC DETAIL REQUIREMENTS

LOG J-HOOK VANE

DRAFT - NOT TO BE USED FOR CONSTRUCTION

SHEET NUMBER	
1 OF 1	
STD. NO.	REV.
XX.XX	