

**CITY OF CHARLOTTE
DEPARTMENT OF GENERAL SERVICES- CITY PROCUREMENT
600 EAST FOURTH STREET,
3RD FLOOR
CHARLOTTE, NORTH CAROLINA 28202**

Date: **June 27, 2023**

Bid Number: **269-2023-061**

Subject: Invitation to Bid on the following apparatus, supplies, materials, equipment and/or services for:
TRAFFIC SIGNAL COMPONENTS & CABINET RISERS

This letter extends an invitation for the submission of a Bid to supply the City of Charlotte with apparatus, supplies, materials, equipment and/or services as indicated above. The City of Charlotte uses a Bonfire e-Procurement Portal ("Procurement Portal" - <https://charlottenc.bonfirehub.com>) for accepting and evaluating bids digitally. Bids must be submitted electronically through the Procurement Portal on or before the Bid Due Date in order to be accepted.

OPTION 3: No Pre-Bid Meeting will be held for this procurement.

Any changes to the terms, conditions or specifications stated in this ITB will be documented in a written addendum and will be posted on the Procurement Portal. Each Bidder is required to acknowledge receipt of all addenda. Please note that we may not consider any Bid that fails to acknowledge receipt of each issued addendum.

A response from your Company to this ITB would be appreciated. Questions should be submitted in writing through the **Vendor Discussions** section on the Procurement Portal.

Sincerely,

Christina Hollonquest
Commodities Sr. Procurement Agent

Checklist for Submitting a Bid:

- Step 1** **Read the document fully.**
- Step 2** Review the solicitation timeline and upcoming events in the Procurement Portal, and download copies of any documents if you plan to submit a .
- Step 3** (Optional) Submit any questions via the Vendors Discussion Section in the Procurement Portal by the deadline(s) noted for the solicitation.
- Step 4** Conduct a thorough review of the Sample Contract. Any exceptions to the Sample Contract must be uploaded in word format (with redlines/tracked changes) or alternatively, submit an “Exceptions Form.” A template of the “Exceptions Form” is found under the Public Files in the Procurement Portal.
- Step 5** Monitor the Procurement Portal for any addendums and/or responses to questions.

If you plan to submit a Bid, you must submit all required documents and respond to all questions within the Procurement Portal for the ITB

If awarded a contract, your company will be required to provide an insurance certificate(s) that meets or exceeds the requirements set forth in the Sample Contract.

TABLE OF CONTENTS

INSTRUCTIONS TO BIDDERS..... 5

- 1.1. REVIEW AND COMPLY:5
- 1.2. DEFINITIONS:5
- 1.3. CONTRACT DOCUMENTS:.....7
- 1.4. EXCEPTIONS:.....7
- 1.5. MULTIPLE/ALTERNATE BIDS:7
- 1.6. HOW TO PREPARE BID RESPONSES:7
- 1.7. HOW TO SUBMIT BID RESPONSES:7
- 1.8. TRADE SECRETS AND PERSONAL IDENTIFICATION INFORMATION:.....8
- 1.9. QUESTIONS:8
- 1.10. HOW TO SUBMIT AN OBJECTION RELATING TO THIS INVITATION TO BID:9
- 1.11. BINDING OFFER:9
- 1.12. ERRORS IN BIDS:9
- 1.13. CITY’S RIGHTS AND OPTIONS:9
- 1.14. BIDS ON ALL OR PART:10
- 1.15. INVITATION TO BID NOT AN OFFER:10
- 1.16. CHARLOTTE BUSINESS INCLUSION PROGRAM:.....10
- 1.17. EQUAL OPPORTUNITY:.....10
- 1.19. NO COLLUSION OR CONFLICT OF INTEREST:10
- 1.20. ANTI-LOBBYING PROVISION:11
- 1.21. CERTIFIED TEST REPORT:11
- 1.22. BRAND NAME:11
- 1.23. TO SUBMIT A PROPOSED ALTERNATE PRODUCT IN LIEU OF A SPECIFIED BRAND:.....11
- 1.24. INITIAL EVALUATION OF SAMPLES:12
- 1.25. STATUTORY REQUIREMENTS:12
- 1.26. GUARANTOR:12
- 1.27. AWARD CRITERIA:12
- 1.28. ENVIRONMENTAL PREFERABLE PURCHASING:.....13
- 1.29. CONTRACT AWARD BY CHARLOTTE CITY COUNCIL:13
- 1.30. PROCUREMENT SCHEDULE.....13
- 1.31. POST AWARD CONFERENCE:14

TERMS AND CONDITIONS..... 15

- 2.1. CONTRACT TYPES:.....15
- 2.2. TERMS OF CONTRACT:15
- 2.3. NOTICE TO PROCEED:15
- 2.4. DELIVERY TIME:15
- 2.5. PRICES ARE FIRM:15
- 2.6. PROMPT PAYMENT DISCOUNTS:.....16
- 2.7. QUALITY:.....16
- 2.8. INSPECTION AT BIDDER’S SITE:16
- 2.9. CERTIFICATION OF INDEPENDENT PRICE DETERMINATION:16
- 2.10. INSURANCE:16

SPECIFICATIONS..... 17

3.1. BACKGROUND:.....	17
3.2. SCOPE:	17
3.3. RESERVED.....	17
3.4. QUANTITIES:	17
3.5. PRODUCT SPECIFICATIONS:.....	17
3.6 PRODUCT STANDARDS:	49
3.7 ALTERNATE PRODUCTS:	49
3.8 WARRANTY:	49
3.9 INSTALLATION:	50
3.10 PRICING:	50
3.11 DELIVERY:	50
3.12 DELIVERY PERSONNEL:	50
3.13 INVOICES:	50
3.14 AWARD OF CONTRACT:.....	51
3.15 CITY CONTRACTING REQUIREMENTS:.....	51
3.16 ITEMS UNDER CONTRACT:	51
3.17 CUSTOMER SERVICE REPRESENTATIVE:.....	51
3.18 PERMITTING RESPONSIBILITIES:.....	52
3.19 NO LIMITATIONS ON DISCLOSURE.	52
3.20 CITY DEPARTMENT PARTICIPATION:.....	52
3.21 RETURNS AND RESTOCKING CHARGES:	52
3.22 PLACEMENT OF ORDERS:	52
3.23 PRODUCT SPECIFICATIONS AND OR EQUAL STANDARD.....	52
3.24 REPORTING:	57

INSTRUCTIONS TO BIDDERS

1.1. Review and Comply:

Each reference to this Invitation to Bid (“ITB”) includes all components listed in the Table of Contents above. Please review each of them carefully. Bidders will be held accountable for having full knowledge of the contents of this ITB and for performing any due diligence that may be necessary to submit a binding Bid.

1.2. Definitions:

Addendum: Refers to any and all modifications or additions to this Invitation to Bid that are issued in writing by City Procurement.

Bid: Refers to a bid submitted by a company in response to this Invitation to Bid. A Bid shall be submitted on the Procurement Portal.

Bid Response Forms: Refers to the forms that a Bidder is required to complete and return as its Bid, as included in the Public Files on the Procurement Portal .

Bidder: Refers to a person or entity that submits a Bid.

CBI: Refers to the Charlotte Business INClusion office of the City of Charlotte.

CCPA: Refers to the Charlotte Cooperative Purchasing Alliance.

Charlotte Combined

Statistical Area (CSA): Refers to the area consisting of the North Carolina counties of Anson, Cabarrus, Cleveland, Gaston, Iredell, Lincoln, Mecklenburg, Rowan, Stanly, and Union, and the South Carolina counties of Chester, Lancaster, and York; a criteria used by Charlotte Business INClusion to determine eligibility to participate in the program.

City: Refers to the City of Charlotte, North Carolina.

Company: During the solicitation process, refers to a company that has interest in providing the Products and Services. After the solicitation process, refers to a company that enters into a Contract with the City for all or part of the Products and Services covered by this ITB.

Contract: A contract under which a Bidder agrees to provide all or part of the Products and Services to the City. A Contract shall include the Terms and Conditions set forth in the Sample Contract provide in the Public Files on the Procurement Portal..

Environmentally

Preferable Products: Products that have a lesser or reduced effect on human health and the environment when compared with competing products that serve the same purpose. This comparison may consider raw materials acquisition, production, manufacturing, packaging, distribution, reuse, operation, maintenance, or disposal of the product.

Minority Business

Enterprise (MBE): Refers to a business enterprise that: (i) is certified by the State of North Carolina as a Historically Underutilized Business (HUB) within the meaning of N.C. Gen. Stat. § 143-128.4; (ii) is at least fifty-one percent (51%) owned by one or more persons who are members of one of the following groups: African American or Black, Hispanic, Asian, Native American, or American Indian; and (iii) has a significant business presence in the Charlotte Combined Statistical Area.

Section One Instructions to Bidders

MWSBE:	Refers to SBEs, MBEs and WBEs, collectively.
MWSBE Goal:	If an ITB or Contract has separate Subcontracting Goals for MBEs, WBEs, and/or SBEs, the term MWSBE is a shorthand way to refer collectively to all MBE, WBE, and SBE Goals set for the RFP. In some instances, the City may set one combined goal for MBEs, WBEs, and/or SBEs, in which event the term MWSBE Goal refers to that one, combined goal. In the latter instance, calculated as a percentage, the MWSBE Goal represents the total dollars spent with MBEs, WBEs, and SBEs as a portion of the total Proposal amount, including any contingency.
Post-Consumer Recycled Material:	Refers to material and by-products which have served their intended end-use by a consumer and have been recovered or diverted from solid waste. It does not include those materials and by-products generated from, and commonly reused within, an original manufacturing process.
Procurement:	Refers to the City of Charlotte’s Department of General Services - City Procurement.
Products:	Refers to all products that the Bidder agrees to provide to the City as part of its Bid.
Recyclability:	Products or materials that can be collected, separated or otherwise recovered from the solid waste stream for reuse, or used in the manufacture or assembly of another package or product, through an established recycling program. For products that are made of both recyclable and non-recyclable components, the recyclable claim should be adequately qualified to avoid consumer deception about which portions or components are recyclable.
Recycled Material:	Refers to material and by-products which have been recovered or diverted from solid waste for the purpose of recycling. It does not include those materials and by-products generated from, and commonly reused within, an original manufacturing process.
Services:	Refers to all services that the Bidder agrees to provide to the City as part of its Bid, including but not limited to training, warranty and maintenance.
Small Business Enterprise (SBE):	Refers to a business enterprise that is certified by the City of Charlotte under Part E of the CBI Policy as meeting all of the requirements for SBE certification.
Specifications:	Refers to the written description of the functions or features of the Products and Services for which the City seeks bids, as shown in Section 3.
Terms and Conditions:	Refers to the City’s standard contractual terms and conditions as set forth in the Sample Contract.
Women Business Enterprise (WBE):	Refers to a business enterprise that: (i) is certified by the State of North Carolina as a Historically Underutilized Business (HUB) within the meaning of N.C. Gen. Stat. § 143-128.4; (ii) is at least fifty-one percent (51%) owned by one or more persons who are female; and (iii) has a significant business presence in the Charlotte Combined Statistical Area.

1.3. Contract Documents:

Each Bid constitutes an offer to become legally bound to a Contract with the City incorporating the ITB and the Bidder's Bid. Upon Contract award by City Council, the City will send the successful Bidder the Contract, which shall consist of the Terms and Conditions contained in the Sample Contract, together with all attachments referenced therein.

1.4. Exceptions:

Each Bid submitted in response to this ITB constitutes a binding offer to comply with all terms, conditions, special conditions, specifications, and requirements stated in this ITB (including but not limited to the Terms and Conditions), except to the extent that a Bidder takes exception to such provisions in the manner required by this Section. To take exception to a provision of this ITB or Sample Contract, the Bidder must either upload a redlined version or an "Exceptions Form" via the Procurement Portal identifying each exception. Exceptions should clearly identify the following items: (1) indicate the number and title of each section of this ITB that the Bidder takes exception to; (2) identify the specific sentence within such section that the Bidder takes exception to; and (3) include any alternate provision proposed by the Bidder.

If exceptions are not identified by way of an uploaded redline version or by way of an Exceptions Form, then they may not be considered during Contract negotiations. Bidders are also reminded that a material variance from the terms of this ITB may result in the Bid being rejected by the City.

1.5. Multiple/Alternate Bids:

No Bidder shall submit more than one (1) Bid unless multiple or alternate Bids are requested in the Special Conditions. Unless specifically stated in the Special Conditions, any multiple or alternate Bids must be brought to the City's attention either during the Pre-Bid Conference or submitted in writing at least five (5) days prior to the opening of the Bid.

1.6. How to Prepare Bid Responses:

All bids shall be prepared as follows:

- Complete the Bid Response Forms provided in the Procurement Portal under the "Requested Information " Bid responses must be submitted only on these forms.
- Bid responses must be typewritten, signed by the Bidder or the bidding firm's authorized representative. All erasures or corrections must be initialed and dated by the person who signs the Bid Response Form on behalf of the Bidder.
- Bids must be accompanied by accurate descriptions of the exact materials, supplies, vehicles, and/or equipment offered for purchase. The Specifications may require that copies of detailed factory specifications, ratings, technical data, etc. be submitted along with the Bidder's response package.

1.7. How to Submit Bid Responses:

All Bidders shall:

- Submit their electronic Bid proposal via the Procurement Portal at <https://charlottenc.bonfirehub.com> no later than **August 22, 2023**, at **11:30** a.m. EST. The original Bid shall be complete and unabridged, and shall not refer to any other copy of the signed and sealed original for any references, clarifications, or additional information. When received, all Bids and supporting materials, as well as correspondence relating to this ITB, shall become the property of the City.

Bids not received by the time and date specified in this section will not be considered, unless the delay is a result of the negligence of the City, its agents, or assigns.

Note that the Bid opening date listed above is based on the assumption that one or more Bidders will submit samples of alternate products for evaluation by the City. In the event no samples are submitted, or in the event the evaluation does not require as much time as anticipated, the City may move up the Bid opening date by issuing a written addendum to this ITB. The City reserves the right to change the Bid opening date, or any other dates relevant to this procurement process, at any time in its sole discretion.

1.8. Trade Secrets and Personal Identification Information:

Definition

Upon receipt by City Procurement, all materials submitted by a Bidder (including the Bid) are considered public records except for: (1) material that qualifies as “trade secret” information under N.C. Gen. Stat. § 66-152 et seq. (“Trade Secrets”), or (2) “personal identification information” protected by state or federal law, to include, but not be limited to, Social Security numbers, bank account numbers, and driver’s license numbers (“Personally Identifiable Information” or “PII”).

Instructions for Marking and Identifying Trade Secrets

If any Bid contains Trade Secrets or PII, such Trade Secrets and PII must specifically and clearly be identified in accordance with this Section by clearly separating them from the rest of the Bid and marked either “Personally Identifiable Information – Confidential” or “Trade Secret— Confidential and Proprietary Information.” This confidentiality caption must appear on each page of the Trade Secret or PII materials, and the document(s) must be submitted separately in the Procurement Portal.

Availability of Bids to City Staff and Contractors

By submitting a Bid, each Bidder agrees that the City may reveal any Trade Secret materials and PII contained therein to all City staff and City officials involved in the selection process, and to any outside consultant or other third parties who assist in the selection process or who are hired or appointed by the City to assist in the selection process.

Availability of Bids via Public Records Requests

Any person or entity (including competitors) may request Bids submitted in response to an ITB. Only those portions of ITBs properly designated as Trade Secret or PII are not subject to disclosure. The public disclosure of the contents of a Bid or other materials submitted by a Bidder is governed by N.C. Gen. Stat. §§ 132 and 66-152, et seq.

When determining whether to mark materials as Trade Secret, please note the following:

- Entire Bids may not be marked as Trade Secret; and
- Pricing may not be marked as Trade Secret.

The City may disqualify any Bidder that designates its entire Bid as a Trade Secret or PII, or any portion thereof that clearly does not qualify under applicable law as a Trade Secret or PII. Each Bidder agrees to indemnify, defend, and hold harmless the City and each of its officers, employees, and agents from all costs, damages, and expenses incurred in connection with refusing to disclose any material that the Bidder has designated as a Trade Secret or PII. This includes an obligation on the part of the Bidder to defend any litigation brought by a party that has requested Bids or other information that the Bidder has marked Trade Secret or PII.

1.9. Questions:

To ask questions about this ITB, please submit a question in writing under the **Vendor Discussion** section on the Procurement Portal; Other than these permitted questions, Bidders should refrain from contacting City staff prior to the Bid opening date. **The City is not bound by any statements, representations or clarifications regarding this ITB other than those provided in writing by the Procurement Officer.**

Questions should reference the ITB page and topic number. Questions must be submitted by **4:00 p.m. EST on August 15, 2023.**

The City will post answers to questions posed by prospective Bidders and/or general information concerning this ITB in the form of an addendum to the ITB on the Procurement Portal. It is the responsibility of the prospective Bidder to check the Procurement Portal for any addenda issued for this ITB.

A Pre-bid Conference will not be held for this solicitation.

1.10. How to Submit an Objection Relating to This Invitation to Bid:

When a Pre-Bid Conference is scheduled, Bidders should either present their objection at that time (either verbally or in writing), or submit a written objection through the Procurement Portal prior to the scheduled Pre-Bid Conference.

When a Pre-Bid Conference is not scheduled, Bidders must submit objections through the Procurement Portal in writing at least ten (10) days prior to the opening of the Bid.

Except for objections raised at the Pre-Bid Conference, all objections must be in writing directed to the Procurement Officer designated in the preceding section.

Failure to object in the manner specified above shall constitute a waiver of any objections the Bidder may have to the terms of this ITB, or anything that occurred in the Bid process through the end of the Pre-Bid Conference.

1.11. Binding Offer:

Each Bid shall constitute a firm offer that is binding for one hundred twenty (120) calendar days from the date of the Bid opening.

1.12. Errors in Bids:

Withdrawal of inadvertently erroneous Bids may be permitted where appropriate, if the request is submitted to the City within seventy-two (72) hours after Bid opening, not including Saturdays, Sundays, and other days the City of Charlotte is not open to the public for business. A request for withdrawal must be made in writing directed to PROCUREMENT_OFFICER through the Procurement Portal. Consideration of a request to withdraw a bid will be made in accordance with N.C. Gen. Stat. § 143-129.1.

In case of Bidder errors calculating “extended” prices stated in a Bid, the unit prices shall govern.

1.13. City’s Rights and Options:

The City reserves the following rights, which may be exercised at the sole discretion of the City of Charlotte:

- to supplement, amend, substitute or otherwise modify this ITB at any time;
- to cancel this ITB with or without the substitution of another ITB;
- to take any action affecting this ITB, this ITB process or the Products or Services subject to this ITB that would be in the best interests of the City;
- to issue additional requests for information;
- to require one or more Bidders to supplement, clarify or provide additional information in order for the City to evaluate the Bids submitted;
- to conduct investigations with respect to the qualifications and experience of each Bidder;
- to change the Bid opening date or any other dates relevant to this ITB;
- to waive any defect or irregularity in any Bid received;

- to reject any or all Bids;
- to award all, none, or any part of the items that is in the best interest of the City, with one or more of the Bidders responding, which may be done with or without re-solicitation; and
- to enter into any agreement deemed by the City to be in the best interest of the City, with one or more of the Bidders responding.

1.14. Bids on All or Part:

Unless otherwise specified by the City or by the Bidder, the City reserves the right to make award on all or part of the items to be purchased. Bidders may restrict their bids to consideration in the aggregate by so stating in the Bid. However, Bids restricted to consideration in the aggregate must also include a unit price on each item Bid.

1.15. Invitation to Bid Not an Offer:

This ITB does not constitute an offer by the City. No recommendations or conclusions from this ITB process shall constitute a right (property or otherwise) under the Constitution of the United States or under the Constitution, case law, or statutory law of North Carolina.

1.16. Charlotte Business INclusion Program:

Pursuant to Charlotte City Council's adoption of the Charlotte Business INclusion (CBI) Policy, the CBI program promotes diversity, inclusion, and local business opportunities in the City's contracting and procurement process for Minority, Women, and Small Business Enterprises (MWSBEs) with a significant business presence in the Charlotte Combined Statistical Area (CSA). The CBI Policy is posted at www.charlottebusinessinclusion.com.

The City is committed to promoting opportunities for maximum participation of certified MWSBEs on City-funded contracts at both the Prime and Subcontract level. For MWSBE participation to count towards a Goal, MWSBEs must meet both the certification and geographic requirements as detailed throughout this solicitation and in the CBI Policy.

1.17. Equal Opportunity:

The City has an equal opportunity purchasing policy. The City seeks to ensure that all segments of the business community have access to supplying the products and services needed by City programs. The City provides equal opportunity for all businesses and does not discriminate against any Bidders regardless of race, color, religion, age, sex, and national origin or disability.

1.18. Title VI Solicitation Notice: Note: Unless otherwise stated herein, this section is only applicable to purchases made by or on behalf of the Aviation Department.

The City, in accordance with the provisions of Title VI of the Civil Rights Act of 1964 (78 Stat. 252, 42 USC §§ 2000d to 2000d-4) and the Regulations, hereby notifies all bidders or offerors that it will affirmatively ensure that for any contract entered into pursuant to this advertisement, disadvantaged business enterprises or airport concession disadvantaged business enterprises will be afforded full and fair opportunity to submit bids in response to this invitation and no businesses will be discriminated against on the grounds of race, color, national origin (including limited English proficiency), creed, sex (including sexual orientation and gender identity), age, or disability in consideration for an award.

1.19. No Collusion or Conflict of Interest:

By responding to this ITB, the Bidder shall be deemed to have represented and warranted that the Bid is not made in connection with any competing Bidder submitting a separate response to this ITB, and is in all respects fair and without collusion or fraud.

Bidder shall also be deemed to have represented and warranted that none of Bidder's or its subcontractors' owners, employees, directors, or contractors will be in violation of the City's

Conflict of Interest Policy for City, Secondary and Other Employment Relationships (HR 13) if a Contract is awarded to the Bidder.

1.20. Anti-lobbying Provision:

Maintaining the integrity of its ITB process is of paramount importance for the City. To this end, we ask each Bidder's cooperation in voluntarily refraining from contacting any members of the Charlotte City Council until the award of this Contract is presented to them for approval.

1.21. Certified Test Report:

If the Specifications or Special Conditions require a certified test report, Bidders shall provide such report at their expense, prior to or with their sealed Bids. The certified test report shall be from a recognized independent testing laboratory or manufacturer's quality control laboratory and shall show all test results and full compliance with the applicable Specifications.

1.22. Brand Name:

If and whenever brand names, makes, names of manufacturers, trade names, Bidder catalogs or model numbers are stated in this ITB, they are for the purpose of establishing a grade or quality of material. The City will evaluate any approved alternates to specified brand names as provided in Section 1.23 of this ITB, except for items identified in Section 3 as Products for which no substitute is acceptable.

1.23. To Submit a Proposed Alternate Product In Lieu of a Specified Brand:

A Bidder that desires to submit a proposed alternate Product in lieu of a brand specified in Section 3 of this ITB (referred to as an "Alternate") must notify the City via the **Vendor Discussion** section on the Procurement Portal no later than **3:00 p.m. EST on July 11, 2023**, that it intends to submit one or more Alternates for evaluation and/or testing. A Bidder may submit more than one Alternate for an individual item included in the Specifications if the Bidder so elects. The Bidder's notice to the City must identify each Alternate that the Bidder intends to submit by manufacturer, style number (if available) and general description of the product.

Following receipt of this notice, the City will notify the Bidder in writing of the number of samples to be submitted for each Alternate proposed, and the sizes that the samples must be submitted in. The Bidder must submit samples of each proposed Alternate for evaluation to **Christina Hollonquest** at no later than **3:00 p.m. EST on July 25, 2023**. The samples must be in the number specified by the City, and must be accompanied by:

- A written statement identifying the manufacturer, brand name, make and, if applicable, style number;
- Any descriptive literature such as illustrations, drawings or data that are necessary for the City to make a comparison with the brand specified for that item in Section 3; and
- Certified test reports (if applicable) by an independent laboratory attesting that the proposed Alternate is equal to or better than the specified brand with respect to the applicable specifications for which certified test reports are required.

All samples submitted will become the property of the City upon receipt by the City. In submitting a sample, each Bidder agrees that the sample does not contain Trade Secret material, and that it may be disclosed by the City to any person or entity in the City's sole discretion. All samples will be made available for inspection by all Bidders.

Samples must be an exact and true representation of the actual Products that will be offered in response to the ITB. Samples shall not include the manufacturer's label sewn in the garments. Samples shall be provided at no cost to the City.

Section One Instructions to Bidders

The City reserves the right to require additional samples for further testing if the City deems it necessary. The City also reserves the right to require Bidders to have their samples tested by an independent laboratory if the City so directs. In such event, the Bidder shall provide the requested additional samples within five (5) business days at no cost to the City.

Failure to comply with each of the above requirements with respect to a proposed Alternate shall result in the City rejecting the Alternate as an acceptable “or equal” for a specified brand.

The City cannot be responsible for testing and/or accepting every new or evolving product proposed and reserves the right to reject proposed products that do not meet the City’s current business model.

1.24. Initial Evaluation of Samples:

Upon receipt of the samples, a committee of City employees (the “Evaluation Committee”) will conduct an initial evaluation to determine whether the samples appear to be “or equal” Alternates for the brand names listed in Section 3 of this ITB. In making this determination, the Evaluation Committee will inspect the samples received for compliance with the Specifications.

During the initial evaluation phase, the City reserves the right to contact Bidders as the City deems necessary with questions or concerns regarding the samples submitted or with requests for additional documentation, samples or information. Bidders must promptly comply with all such requests. It is the Bidder’s responsibility to prove to the City that each proposed sample is equal to or better than the grade or quality of the brand name specified in the ITB.

The City will evaluate the merits of the grade or quality of the samples based on the information furnished by the Bidder. The City is not responsible for locating or obtaining any information not identified in the request for approval. The City shall be the sole judge in determining the product acceptability of all “or equal” products.

The City shall notify the Bidder of the decision in writing and post any approved “or equal” products in the form of an addendum to the ITB on the Procurement Portal.

1.25. Statutory Requirements:

Any Bid submitted in response to this ITB shall be deemed to include full conformance with all statutory requirements of North Carolina and all statutory requirements of the Federal Government, to the extent applicable. It is the responsibility of each Bidder to conduct its own due diligence as to what statutory requirements may apply.

1.26. Guarantor:

If the Bidder is a subsidiary of another entity, the City requires that the Bidder’s parent entity provide a guarantee of payment of all of the Bidder’s obligations under the Contract. The City may also require that the Bidder obtain a guaranty from an entity other than the parent if the City concludes that such guaranty would be beneficial to protect the City’s interest. If the Bidder is not a subsidiary, the City may require that the Bidder obtain a guaranty of payment from another entity if the City concludes that such guaranty would be beneficial to protect the City’s interest. If a guarantor is required, the Bidder must: (1) identify a guarantor that is acceptable to the City, (2) provide the City with the same financial information about the guarantor that the Bidder is required to provide about itself under this ITB; and (3) provide the City with a signed, legally binding guaranty agreement from the approved guarantor that is acceptable to the City in the City’s sole discretion. Failure to comply with the foregoing shall be grounds for rejection of the Bidder’s Bid.

1.27. Award Criteria:

The City reserves the right to award a Contract to the lowest responsive responsible Bidder taking into consideration vendor qualifications and experience, quality, delivery, workmanship, services,

and reporting. The City reserves the right to reject any Bid on the basis of function, compatibility with user requirements of utility, as well as cost.

1.28. Environmental Preferable Purchasing:

The City promotes the practice of Environmentally Preferable Purchasing (EPP) in acquiring Products or Services. Applicable EPP attributes that may be taken into consideration as environmental criterion include the following:

- | | |
|-----------------------------|--|
| Recycled content | Renewable resources |
| Recyclability | Reduced Packaging |
| Biodegradability | Reduced toxicity |
| Compostability | Low Volatile Organic Compounds (LVOCs) |
| Energy and Water Efficiency | Pollution Prevention |
| Life Cycle Management | End of Life Management |

Bidders able to supply Products or Services containing any of the applicable environmentally preferable attributes that meet performance requirements are encouraged to offer them in their Bids. Bidders must provide certification of environmental standards and other environmental claims, such as recycled content and emissions data, or a formal statement signed by a senior company official.

1.29. Contract Award by Charlotte City Council:

The Contract to be awarded under this ITB must be approved by the Charlotte City Council. If such approval is granted, City Procurement will provide the Contract to the Bidder for the Bidder to sign and return. In the event City Council approval is not received within one hundred twenty (120) calendar days after opening of the Bids, the Bidder may request that it be released from the Bid.

1.30. Procurement Schedule

The following chart shows the schedule of events for the conduct of this ITB. The key events and deadlines for this process are as follows, some of which are set forth in more detail in the Sections that follow:

DATE	EVENT
1. June 27, 2023	<i>Issuance of ITB.</i> The City issues this ITB.
2. July 11, 2023	<i>Notice of Alternatives.</i> Prospective Bidders shall submit <u>notice of alternatives</u> in lieu of specified bran no later than 5:00 p.m. on DATE per Section 1.23.
3. July 25, 2023	<i>Submission of Samples.</i> All potential Bidders are required to submit samples as outlined in Section 1.23 of this ITB. All samples must be received by July 25, 2023 at 3:00 p.m. No exceptions.
4. July 25, 2023 - August 1, 2023	<i>Initial Sample Evaluation.</i> All samples will be tested and evaluated per Section 1.24.
5. August 1, 2023	<i>Notice of Approved Samples.</i> City will issue notice to all Prospective Bidders of samples approved from testing and evaluation along with a revised pricing sheet of the approved alternates.

Section One
Instructions to Bidders

6. August 15, 2023	<i>Final Submission of Written Questions.</i> Final questions due no later than 4:00 p.m.
7. August 22, 2023	<i>Bid Submission and Bid Opening.</i> Bids are due by 11:30 a.m. on August 22, 2023. Please arrange for bid delivery per instructions in Section 1.7. All Bids will be time-stamped upon receipt and held in a secure place until this date. All Bids will be opened and publicly read aloud via Microsoft Teams. Late submissions will not be accepted.
8. August 22, 2023 – August 23, 2023	<i>Bid Evaluation.</i>
9. September 25, 2023	<i>Contract Award by Council.</i>
10. October 6, 2023	<i>Anticipated Contract Effective Date</i> Company begins providing the Products.

1.31. Post Award Conference:

A Post-Award Conference may be scheduled as soon as practical after the award of the Contract. The Company shall attend the conference along with the Company’s prospective Project Manager and any anticipated major subcontractors, and shall provide at such conference a written schedule for the delivery of any Products or Services for which no delivery dates have been specified in this ITB.

TERMS AND CONDITIONS

Each Bid submitted in response to this ITB constitutes an offer to become legally bound to a Contract incorporating terms and conditions set forth in this Section 2 as well as the Terms and Conditions in the Sample Contract. For purposes of this Section, a Bidder that enters into a Contract with the City may be referred to as the “successful Bidder” or the “Company.”

2.1. Contract Types:

The Contract resulting from this Invitation to Bid will be of the type indicated below:

Definite Quantity: The Contract will be a fixed-price contract that provides for delivery of a specified quantity of Products and Services either at specified times or when ordered.

Indefinite Quantity: The Contract will be a unit price contract for an indefinite amount of Products and Services to be furnished at specified times, or as ordered. In some cases, indefinite quantity contracts may state a minimum quantity that the City is obligated to order. The City may make available to Bidders information regarding the City’s purchase history or projected estimates of the approximate quantity of Products that will be needed. The City makes no representations as to the accuracy of such information. Each Bidder is required to perform its own due diligence on which to base its bid. Inaccuracy of purchase history or projected quantity estimates provided by the City will not give rise to any claim against the City, or entitle any Bidder to rescind its bid or terminate or amend the Contract.

2.2. Terms of Contract:

Unit Price Contract: Contract awarded is for a unit price when product and service needs are based upon indefinite quantities, and where orders will be based on actual needs that may exceed or be less than projections. All expenditures under a unit price contract are contingent upon appropriations having been made by Charlotte City Council.

Contract Terms and Renewal Options: The Contract term shall be for a period of three (3) years from the date of award. The City, at its option, may extend the Contract for up to two (2) additional one-year extensions unless the Bidder objects in writing at least ninety (90) days prior to the beginning of the extension term.

One Time Purchase: Contract awarded is for a specific quantity purchased at one time.

2.3. Notice to Proceed:

The successful Bidder shall not commence work or make shipment under this ITB until duly notified by receipt of an executed Contract from the City and/or through a Purchase Order (PO) . If the successful Bidder commences work or makes shipment prior to that time, such action is taken at the Bidder's risk, without any obligation of reimbursement by the City.

2.4. Delivery Time:

When delivery time is requested in this ITB (whether in the form of a specific delivery date or maximum number of days for delivery), time is of the essence. Each Bid shall be deemed a binding commitment of the Bidder to meet the delivery time stated herein unless the Bid specifically takes exception. If such delivery time is not met, the City shall be entitled to terminate the Contract immediately for default and/or exercise any other remedies available by law or in equity.

2.5. Prices Are Firm:

Each Bidder warrants the Bid price(s), terms and conditions quoted in its Bid shall be firm for acceptance by the City for a period of one hundred twenty (120) calendar days from the date of the Bid opening. Once award is made and a Contract is in place, prices shall remain firm and fixed for the entire Contract period, unless otherwise allowed in the Special Conditions and stated in the Bid.

2.6. Prompt Payment Discounts:

Bidders are urged to compute all discounts into the price offered. If a prompt payment discount is offered, it will not be considered in the award of the Contract except as a factor to aid in resolving cases of identical prices.

2.7. Quality:

Unless this ITB specifically states otherwise for a particular item, all components used to manufacture or construct any supplies, materials or equipment or Products provided under this Invitation to Bid shall be: (a) new; (b) the latest model; (c) of the best quality and highest grade workmanship; and (d) in compliance with all applicable federal, state and local laws, regulations and requirements. By “new”, the City means that the item has been recently produced and has not been previously sold or used.

Whenever this Invitation to Bid or any other part of the Contract states that a Product or Service shall be in accordance with laws, ordinances, building codes, underwriter’s codes, applicable A.S.T.M. regulations or similar expressions, the requirements of such laws, ordinances, etc., shall be construed to be minimum requirements that are in addition to any other requirements that may be stated in this Invitation to Bid or the Contract.

2.8. Inspection at Bidder’s Site:

The City reserves the right to inspect the equipment, plant, store or other facilities of a Bidder prior to Contract award, and during the Contract term from time to time as the City deems necessary to confirm that such equipment, plant, store or other facilities conform with the Specifications and are adequate and suitable for proper and effective performance of the Contract. Such inspections shall be conducted during normal business hours and upon at least three (3) days’ notice to the Bidder (except that a store may be inspected at any time during regular store hours without notice).

2.9. Certification of Independent Price Determination:

By submission of a Bid, the Bidder certifies, and in the case of a joint Bid each party thereto certifies as to its own organization, that in connection with this procurement:

The prices in the Bid have been arrived at independently, without consultation, communication, or agreement, for the purpose of restricting competition, as to any matter relating to such prices with any other Bidder or with any competitor;

Unless otherwise required by law, the Bidder has not knowingly disclosed the prices that have been quoted in this bid directly or indirectly to any other Bidder or to any competition prior to the opening of the bid; and

No attempt has been made or will be made by the Bidder to induce any other person or firm to submit or not to submit a Bid for the purpose of restricting competition.

2.10. Insurance:

All Bidders must indicate compliance with the Insurance requirements stated in General Conditions of the Sample City Contract.

SPECIFICATIONS

3.1. Background:

The City of Charlotte maintains a large and modern traffic signal system. All materials and equipment used to maintain this system are required to be interchangeable and function with the existing infrastructure. The Charlotte Department of Transportation (CDOT) uses various size traffic cabinets to protect traffic control equipment from the elements. Some cabinets require risers for use in different areas.

3.2. Scope:

The scope of this Invitation to Bid (ITB) is to establish a contract for the purchase, delivery and other inherently related activities of the Products and Services and in compliance with the specifications and terms and conditions set forth in this ITB.

All Products and component parts furnished under the Contract shall be new, shall comply with the specifications and terms and conditions set forth in this ITB, and shall operate in full compliance with these Specifications.

3.3. Reserved.

3.4. Quantities:

The City does not guarantee quantities and will purchase quantities of Products according to actual need during the term of the Contract. The quantities listed in this ITB are estimates only, and may differ substantially from actual quantities ordered. Multiple orders will be placed on an as needed basis during the term of the Contract.

3.5. Product Specifications:

Construction:

The 10" M54 riser is compatible with all manufactures of TS2 M type cabinets that fit the specification dimensions in the drawings below.

The Cabinet riser shall be constructed using 5052-H-32 aluminum. The unpainted sheet aluminum shall have a minimum thickness of 3.2mm (.125") and be able to support a minimum of 100kg (220lbs). All continuous welds shall be neat and of uniform consistency. Holes, notches and or slots shall be machine cut, neat and clean of any metal burrs.

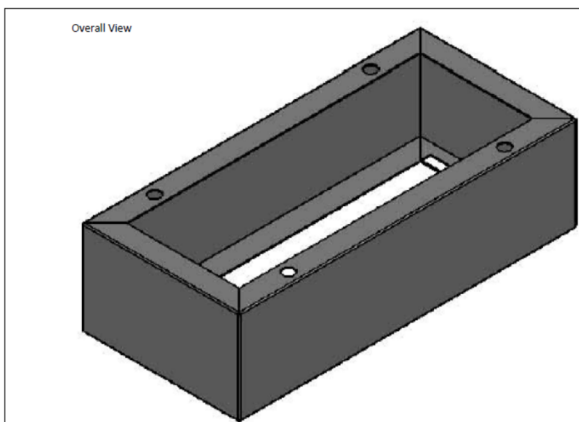

3.5.2 Drawing Specifications:

All drawings are in inches.

Top View

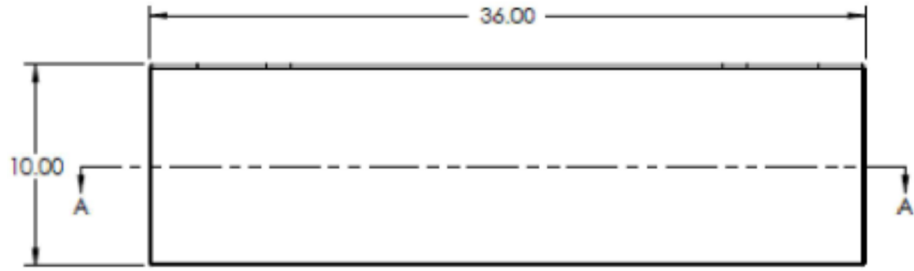

View – Internal View of Bottom

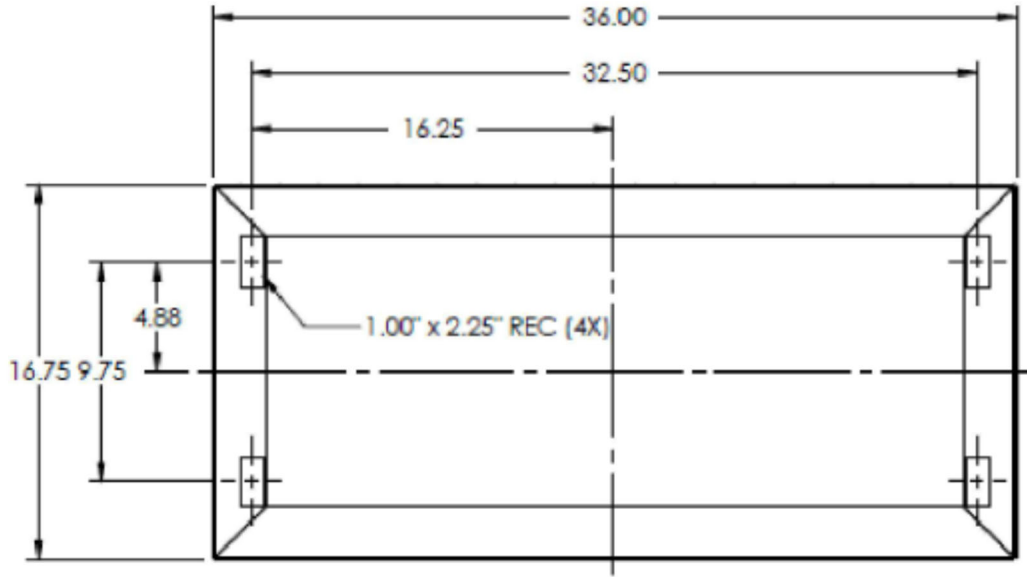

Side View

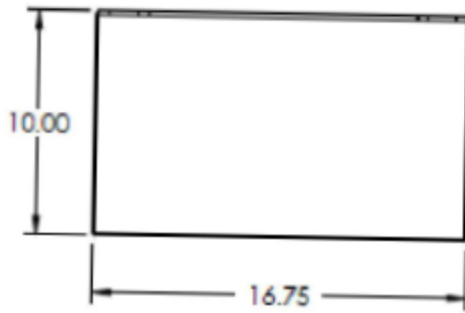

Top View

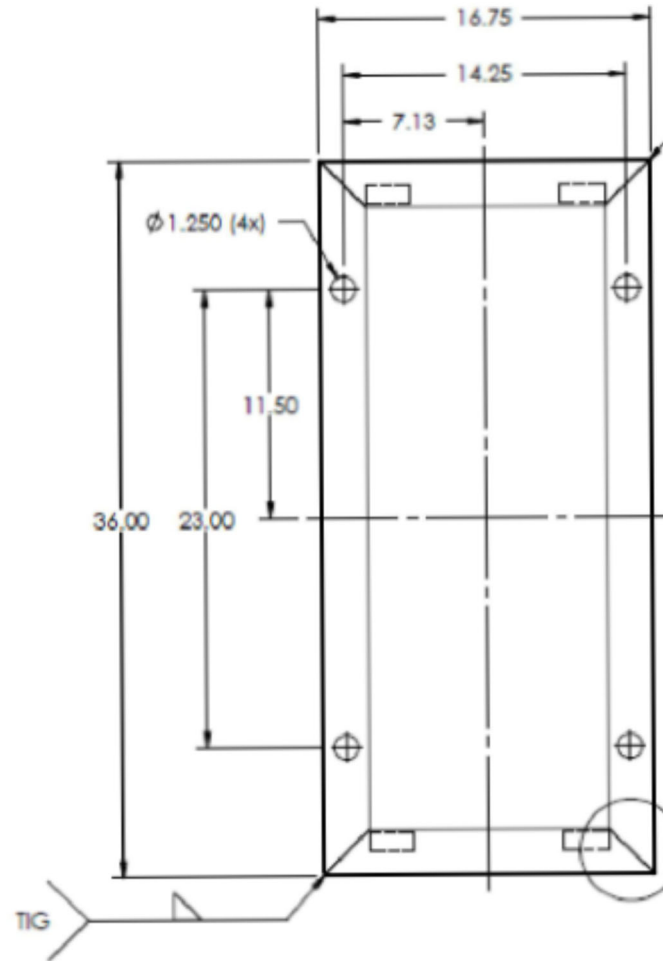

3.5.3 Pedestrian Signal Housing:

The pedestrian signal housing will be used in conjunction with standard of LED pedestrian signal modules to promote pedestrian safety.

- Cast aluminum housing, powder-coated federal yellow, cast aluminum door, painted flat black with visor type (z-crate, waffle mesh, vantage).
- Door shall have stainless steel hinge pins that are removable without using tools.
- All hardware shall be stainless steel.
- Housing shall be drilled on one side for clamshell mounting hardware.
- Position terminal block mounted in housing.
- Front door 16" hinged top or bottom.
- The door shall be attached with stainless clevis or roll pins and eye bolt/wing nut assemblies.
- Two equally spaced mounting lugs, integrally cast into the top and bottom of the 16" and the sides of the 12", allow the doors to hinge from either direction.

3.5.4 Led Pedestrian Signal Modules:

Dialight 430-6479-801X-NC – Countdown is the standardized LED Pedestrian Signal Module for the Charlotte Department of Transportation.

- All shall be fully compliant to the ITE PTCSI Part-2: LED Pedestrian Traffic Signal Modules specifications

- 16"x18" LED Pedestrian Signal Modules.
- Tinted Lenses.
- Long Life with 5-year warranty.
- Fully Sealed Module, Dust and Moisture Resistant.
- Incandescent Appearance.
- Easy to install into existing signal enclosures.
- Operating Temperature: -40 degrees Fahrenheit to 165 degrees Fahrenheit.
- Vibration resistant to MIL-STD-883, Test method 2007.
- Moisture resistance per MIL-STD-810F, Method 506.4 for rain and blowing rain.
- All interior mounting locations on the 16" housing are symmetrically positioned, allowing the rotation of components when using the clamshell bracket to mount to the right or left side.
- Clamshell mounting bracket should not be mounted to housing.
- Housings are to be boxed separately with closure bolt and 2-part mounting assembly symmetrical mounting holes allow for left or right mount neoprene gasket provides a weather tight seal 3 position, 2 row terminal block mounted in the upper half of the signal mounted portion.
- One side with fast-on terminals, the other side with screw terminals 28" wire leads (3) provided to wire clamshell terminal block to pedestrian signal terminal block field wiring is terminated on clamshell terminal block flathead 3/16" hex socket closure bolt.

3.5.5 Pedestrian Signals Visually and Hearing Impaired:

3.5.5.1 System Description:

1. The Audible -Tactile Pedestrian Signal System shall consist of all electronic control equipment, mounting hardware, push buttons and signs, which are designed to provide both a push button raised a raised vibrating tactile arrow on the button along with a variety of audible sounds for different pedestrian signal functions.
2. A 2 Wire APS system consist of push button stations installed on poles with existing pairs of button wires and a Central Control Unit installed in the traffic cabinet. The Central Control Unit powers the push button stations over the two A 2 Wire System must include a Central Control Unit in the cabinet.

3.5.5.2 General Description:

1. The System shall consist of a Central Control Unit (CCU) and Pedestrian Push Button Stations (PBS), as described below, and an iOS device w/the iOS client application, or Android device with Android client application, or Windows PC with BLE dongle and Windows client application, for programming the system settings.
2. The System shall be manufactured by an ISO 9001-2008 (minimum) registered company.
3. System shall meet the requirements of Made in America and/or The Buy American Act.

3.5.5.3 Design Compliance:

1. The system shall meet the functionality requirements of MUTCD 2009. The system shall meet NEMA TS 2 Section 2.1 Temperature & Humidity requirements, or TS4 equivalent.
2. The system shall meet NEMA TS 2 Section 2.1 Transient Voltage Protection requirements, or TS4 equivalent.
3. The system shall meet NEMA TS 2 Section 2.1 Mechanical Shock and Vibration requirements or TS4 equivalent.
4. The system shall meet IEC 61000-4-4, IEC 61000-4-5 Transient Suppression requirements.
5. The system shall meet FCC Title 47 Part 15, Class A Electronic Noise requirements.
6. The Push Button Station (PBS) Enclosure shall meet NEMA 250-Type 4X requirements
7. The Central Control Unit (CCU) Enclosure shall meet NEMA 250 –Type 1 requirements.

3.5.5.4 Functional Requirements:

1. The system shall support at least 16 PBS's per intersection (on at least 1 channel) controlled by as single base unit located in the traffic control cabinet.
2. The system shall be able to be set to vibrate a tactile arrow button during the WALK interval following a button push and/or every time the walk comes up.
3. The system shall have a field-selectable function known as "LOCATE TONE." This means that during the FLASHING DON'T WALK and the DON'T WALK intervals, the system shall provide a location tone that emanates from the Pedestrian Push Button Station. The system shall provide at least 3 different sounds to choose from.
4. The system shall have the field selectable function known as "Extended Push Activation." This is defined as the audible WALK message shall only be activated and audible during the WALK interval if the button is depressed for a field selectable minimum period (from 0.5 to 6 seconds). Also for the following walk and clearance intervals, the volumes have a separately minimum and maximum volume level.
5. The system shall have the field selectable known as "Information Message. This means that a custom message giving the location of the street to cross and the intersection (or other information) will be vocalized only when the button is depressed for a minimum field selectable time.
6. The System shall provide a "Wait" message that plays once the button is activated until the Walk cycle goes into effect. This message must have the field selectable option of OFF or repeating every 4, 6, 8 or 10 seconds.
7. The System shall have standard "Travel Direction" options that can be selected at the time of installation.

8. The System shall have at least 10 field selectable WALK sound options including a cuckoo, a chirp, an MUTCD rapid tick or custom voice message.
9. The System shall provide at least 7 Ped-clearance sound choices including audible countdown (field selectable). The audible countdown shall represent the time remaining during the pedestrian Clearance interval. Timing is automatically adjusted to the CLEARANCE INTERVAL timing, provided by the traffic controller.
10. The System shall provide 2 language capabilities, selectable by user (as a field selectable feature).
11. The System shall provide an Emergency preemption message in conjunction with a preemption system (selectable feature).
12. The system LOCATE TONE, WALK, and DON'T WALK audible features shall have independent assignable minimum and maximum volume limits. CLEARANCE volume level shall be controlled by WALK volume setting.
13. All sounds for all PBS's shall be synchronized.
14. The system shall have a non-visible, ambient sensing microphone located in the pedestrian station in an environmentally protected housing.
15. The LOCATE TONE volume shall adjust automatically in response to ambient noise with field selectable adjustment levels from -30dB below to +20dB above ambient in 2.5dB increments.
16. All other sounds volumes shall adjust automatically in response to ambient noise with field selectable adjustment levels from -30dB below to +20dB above ambient in 5dB increments.
17. The system shall utilize high quality digital audio technology, with a minimum 16-bit sample at a 48-kHz sample rate.
18. The PBS firmware and voice messages shall be updatable via Bluetooth. There shall be no requirement for the IC chips or module hardware to be removed or exchanged in order to complete a firmware or audio update.
19. The System shall have the option to mute sounds on all crosswalks except activated crosswalk (selectable feature).
20. The System shall have a real-time clock capable of keeping time when there is no system power, for at least 2 years from the date of manufacture.
21. The System shall have the ability to have four separate program configuration with all features available, and any single configuration can be selected through an external input.
22. The System shall provide a user settable calendar function, allowing four separate configuration profiles to be configured to become active at different times of the day on a daily, weekly, or holiday basis.
23. The entire System shall be configurable from any PBS over Bluetooth.

24. The entire System shall be configurable from the CCU over Wi-Fi Ethernet.

All field access to selectable options using a Bluetooth, Wi-Fi or Ethernet devices shall be protected using password security.

3.5.6 Pedestrian Signal Push Button Station:

3.5.6.1 Central Control Unit (CCU) - The CCU is the control unit that provides data for the Push Button Stations. The CCU shall be either a shelf mount (CCU-S) or rack mount (CCU-C) assembly.

1. The CCU-S shall be installed inside the Traffic Cabinet and powered by the AC supply mains (115 VAC).
2. The CCU-S shall provide internal power to operate up to 16 PBS's.
3. A 24-volt power brick shall power up to 16 PBS's in a CCU-C configurations.
4. The CCU shall control at least 16 PBS's.
5. The CCU shall be logically configurable to assign any PBS to one of 16 traffic phases.
6. The CCU-S shall receive pedestrian phase Walk, Don't Walk and Clearance inputs from either the traffic cabinet load switches or an SDLC input.
7. The CCU-S shall be capable of operating as a NEMA TS2 Detector Rack Bus Interface Unit (BIU) in order to place PED calls over SDLC.
8. The CCU-C shall receive pedestrian phase Walk, Don't Walk and Clearance inputs from a Transport Electrical Equipment Specification (TEES) C4S connector.
9. The CCU shall be able to self-test all PBS's and put a corresponding phase into recall should a PBS assigned to a phase fail the self-test.
10. The CCU-S shall provide optically isolated general-purpose inputs.
11. The CCU-S shall be used with a 4-cable interface harness, or SDLC cable, or both.
12. The CCU shall have internal storage to log several hundred events with a date-time stamp for each event.
13. The CCU shall have an internal real-time clock capable of being set in the field and propagating the time to each connected PBS.
14. The CCU firmware shall be updatable via either Wi-Fi or Ethernet. There shall be no requirement for the IC chips or module hardware to be removed or exchanged in order to complete the firmware update.
15. The CCU shall monitor PED interval conflicts and signal affected PBS's to an off state when a conflict occurs.

16. The CCU-S shall meet NEMA 250 – Type 1 enclosures requirements.
 17. The CCU shall have a backlit LCD screen and button interface to allow placing test calls and display status.
 18. The CCU shall have SNTP capability, including the ability to set IP addresses of SNTP servers, to automatically keep the date/time current.
 19. The CCU shall have SNMP ability to respond to SNMP queries for basic information and send out SNMP Trap notifications when critical actions occur within the unit.
- 3.5.6.2 The Pedestrian Head Controller Unit (PHCU) is the power supply and control unit that provides power and data for the Push Button Stations.
1. The PHCU shall be mounted in the ped head (pedestrian signal) and be powered from the 120 VAC, WALK/DON'T WALK ped head lamp indications.
 2. The PHCU Power Requirements shall be: 120 VAC, 60Hz, (100 ma, typical).
 3. The PHCU shall have 3 output wires to the PBS (Power, Data, Ground).
 4. The PHCU shall output one Data wire containing WALK and DON'T WALK information to the PBS.
 5. The PHCU dimensions shall be: 7.3" L x 3.6" W x 1.3" H.
 6. The PHCU must be mountable inside all types of ped heads with the exception of older, neon/transformer type, and low profile ped heads. Electronic circuits (printed circuit board assemblies) shall be in a water-tight housing/enclosure or encapsulated with a thermoplastic polyamide having a UL94-V0 flammability rating and allowing light and RF transmissions (i.e. over-molded), for environmental protection. The housing/closure or encapsulation shall be capable of providing NEMA 250 4X protection to all covered components.
- 3.5.6.3 Pedestrian Push Button Station (PBS) – The PBS allows the pedestrian to place calls to the traffic controller and provides vibro-tactile feedback during the Walk cycle. This equipment is typically mounted on a pole, near the start of the crossing.
1. The PBS shall be mounted to a pole by banding or bolting.
 2. The PBS shall be a single fixture that contains a 2" activation area, in which resides an ADA compliant vibro- tactile push button with a raised directional tactile arrow, and a sign mounted above the button.
 3. The PBS Speaker shall be 8 Ohms, 6 Watt, and weather-proof.
 4. The button shall be cast aluminum, nickel-plated and powder coated black around the arrow, to provide high contrast to arrow color. The PBS arrow shall allow for change in orientation to one of four directions.
 5. The PBS Arrow Button Actuation shall use Hall Effect Sensor technology rated to greater than 20 million operations.

6. The PBS Arrow Button Push Force shall have three adjustable pressure settings between approximately 1 and 3lbs to activate a button push.
7. The PBS Arrow Button shall pulse and vibrate at approximately 20 Hz with displacement factor based on pounds of force used to actuate.
8. The PBS shall have a rear facing speaker projecting sound from front and back, providing 360° omnidirectional sound performance.
9. The PBS shall include internal Conflict Monitoring that monitors WALK, and DON'T WALK input signals for conflict conditions; disables system operation and logs errors if conflict occurs.
10. The PBS firmware and voice messages shall be updatable via Bluetooth. There shall be no requirement for the hardware to be changed out to update.
11. The system shall operate with the vendor's client application to record and upload cumulative ped count & call data.
12. The PBS shall meet or exceed NEMA 250 type 4X enclosure requirements.
13. The PBS Construction shall be:
 - a. FRAME: Cast Aluminum, Powder Coated.
 - b. HOUSING: Reinforced, UL-listed Thermoplastic.
 - c. MESSAGE SIGN: Aluminum, Powder Coated, Ink Markings, or Reflective Vinyl Sheeting
 - d. PUSH BUTTON: Aluminum, Powder Coated.
14. Electronic circuits (printed circuit board assemblies) shall be in a water-tight housing/enclosure or encapsulated with a thermoplastic polyamide having a UL94-V0 flammability rating and allowing light and RF transmissions (i.e. over-molded), for environmental protection. The housing/closure or encapsulation shall be capable of providing NEMA 250 4X protection to all covered components.
15. The PBS Message Marking at the time of order may specify the Message Sign Markings to be the International Walking Person or the Informational Explanations for the three (3) distinct pedestrian displays (WALK, DON'T WALK, and PED CLEAR) that a pedestrian would see on an active pedestrian signal.

3.5.6.4 Field Programming via Client Application (Apple iOS v8.0 or higher devices, or Android 5 or higher devices, or a PC with Windows 7, 8 or 10).

1. The iOS, Android, and PC applications shall be upgradable.
2. The iOS, Android, and PC applications shall notify the user when a newer version of the client application is available.
3. The iOS, Android, and PC applications shall notify the user when newer PBS and CCU firmware is available.
4. The iOS, Android, and PC applications shall provide the mechanism to download the latest PBS and CCU firmware.

5. The iOS, Android, and PC applications shall be capable of setting all volumes and features of the APS system specific to the PBS's.
6. The iOS, Android, and PC applications shall be capable of setting/updating configuration options for a single PBS or all PBS's on the intersection for most functions from a single PBS or CCU (Globalupdating).
7. The iOS, Android, and PC applications shall be capable of storing, modifying, loading, and emailing PBS configuration settings.
8. The iOS, Android, and PC applications shall be capable of storing, loading, extracting, and emailing PBS audio files.

3.5.7 Traffic Signal Controllers:

The traffic signal controllers will be used to control coordination to ensure that traffic and pedestrians move as smoothly and safely as possible.

The City uses Econolite's EOS controller software, the 2070LX must be capable of running, without errors or causing signal malfunctions, the latest version of Econolite's EOS controller software. Furnish controllers and modules that meet the CALTRANS Transportation Electrical Equipment Specifications (TEES) (dated March 12, 2009, plus Errata 1 dated January 21, 2010, and Errata 2 dated December 5, 2014) except as required herein.

3.5.7.1 Provide model 2070LX controllers with Linux kernel 2.6.18 or higher and device drivers, composed of the unit chassis and at a minimum the following modules and assemblies:

- MODEL 2070-2N Field I/O Module
- MODEL 2070-3B, Front Panel Module (FP), Display B (8x40)
- MODEL 2070-4AN, NEMA Power Supply Module

Optional module and assembly to include:

- MODEL 2070-1C, CPU Module, Single Board, with 8Mb Data key (blue in color) – This 1C CPU Module must adhere to the City of Charlotte's CPU Specifications below.
- Provide a Board Support Package (BSP) to the City and to any specified applications software manufacturer when requested by the City to facilitate the porting of application software.
- Ensure blank panels cover all open slots on the back of the controller.

3.5.7.2 EOS 1C CPU

The City uses Econolite's EOS controller software, the CPU must be capable of running, without errors or causing signal malfunctions, the latest version of Econolite's EOS controller software. This specification sets forth the minimum requirements for a 2070-1C CPU designed according to the Caltrans TEES 2009 specification and the ATC Standard V. 6.25. The 2070-1C module consists of an ATC Engine Board paired with a 2070-1C Host Board.

3.5.7.2.1 ATC Engine Board

1. The board shall be fully compliant with the ATC Standard version 6.25.

2. **Microprocessor** - The board shall include a Freescale MPC83XX PowerPC processor with QUICC engine.
3. **DRAM Memory (DDR2)** - The board shall contain a 128Mbytes of DDR2 DRAM memory for application and OS program execution.
4. **Flash Memory** - The board shall contain 64 Mbytes of NOR type FLASH for storage of OS Software and user applications.
5. **Static RAM (SRAM)** - The board shall contain 2MB of SRAM memory for non-volatile parameter storage.
6. **Standby Power** - The board shall provide the Standby Power (VSTANDBY) required for supporting the SRAM and RTC.
7. **Real-Time Clock (RTC)** - The board shall be provided with a software settable, hardware RTC that meets the requirements of the ATC Standard except that in the absence of VPRIMARY, the RTC shall operate from VSTANDBY.
8. **CPU Reset** - A software-driven CPU Reset Signal (Active Low) shall be provided to reset other system devices and shall be accessible by application programs as well as by the command line as "CPU reset". CPU Reset shall be executed when the Controller starts up or is rebooted using the reboot command.
9. **USB** - The board shall provide one USB 2.0 compliant port and provide hot-plug auto-mount.
10. **Ethernet**- The board shall provide three 10/100 auto-negotiating Ethernet ports.

3.5.7.2.2 2070-1C Host Board

The Host Board shall be a single board module meeting Caltrans 2X WIDE board requirements. It shall provide two DIN sockets and mounting standoffs for the connection of the 2070-1C Engine Board, a 96-Pin DIN connector for interfacing with the 2070 Serial Mother Board and all required EIA-485 interface circuitry.

1. **Ethernet Switches** - The board shall provide two Ethernet switches used to route the ENET1 and ENET2 signals from the Engine Board to the front panel RJ-45 connectors and Serial Motherboard connector. The switches shall be managed and provide packet Broadcast Storm protection.
2. **Data key Receptacle** - The board shall provide a single Data key Receptacle capable of hosting 3.3VDC Data keys.
3. **USB** - The board shall route the USB signals from the Engine Board to a three port USB hub chip.
4. **SD Card Support** - The board shall be provided with an industry standard SD Card socket mounted to the host board. The SD Card

socket shall be supported by the USB hub. The SD Card socket shall not be accessible from the front panel.

3.5.7.2.3 Front Panel

The front of the 2070-1C CPU Module shall consist of a panel with a USB port, three Ethernet ports with integrated LEDs, a Data key receptacle, and a 25 pin C13S connector with TX/RX LEDs. It shall only be necessary to remove the module during maintenance of the electronics or for accessing the SD Card.

1. USB Port - The TYPE 2070-1C CPU Module shall include a USB port compliant to the ATC Standard 6.25 with the exception that USB shall conform to the appropriate sections of the USB v2.0 specification for both hardware and software operations. The USB shall be brought out from the Host Board USB hub to the front panel USB connector.
2. Ethernet Ports – Three ETHERNET ports from the Ethernet switches on the Host Board shall be brought out on RJ-45 connectors mounted on the 2070-1C front panel. These Ethernet ports shall support ENET 1 and ENET 2 from the Engine Board.
3. Data Key – A Data key Receptacle™ shall be mounted on the CPU module front panel. The controller shall be supplied with an 8MB Memory Size Data key with each 1C CPU module unless specified otherwise. The Data key shall be temperature rated for –40 °C to +85 °C (–40°F to 185 °F) operation, shall be blue in color. The data key shall operate on 3.3 VDC. Power shall not be applied to the receptacle if the key is not present. The CPU shall support from a 2 through 32MB Data key.
4. C13S Port – The front panel shall provide a DB-25 connector that supports the SP8 circuitry on the Host Module.

3.5.7.2.4 Operating System

The 2070-1C CPU Module shall be supplied with Linux 3.12x or later kernel and Board Support Package (BSP).

1. Linux Drivers – All Linux Drivers provided in the Model 2070-1C CPU shall be compliant to ATC Standard V.6.25 Annex B specifications.
2. Startup Procedure - The Linux boot image shall startup as described in the ATC Standard V.6.25 Section 5.3.5.1. The boot up process shall be completed within 4.5 seconds. Linux startup shall be configured to auto run scripts or execute Linux binaries residing in the USB Memory upon power up or during normal operation with USB Memory inserted.
3. ATC API – Provide compiled libraries and applications for the 5401 Standard for Applications Programming Interface with Reference Implementation (APIRI).

3.5.7.2.5 Electronics

All printed circuit boards shall meet the requirements of the NEMA Standard plus the following requirements to enhance reliability:

1. All plated-through holes and exposed circuit traces shall be plated with solder.
2. Both sides of the printed circuit board shall be covered with a solder mask material.
3. The circuit reference designation for all components and the polarity of all capacitors and diodes shall be clearly marked adjacent to the component. Pin 1 for all integrated circuit packages shall be designated on both sides of all printed circuit boards.
4. All printed circuit board assemblies shall be coated on both sides with a clear moisture-proof and fungus-proof sealant.
5. The controller shall include an option that allows updating software using a Windows based computer or USB memory stick. This option shall allow updating the controller software via Ethernet port or USB port.
6. The controller shall include an option that supports remotely updating the controller software from the Central Server while keeping the intersection in an all-red condition.

3.5.8 Traffic Signal Control Cabinets

The traffic signal cabinet will be used to house the mounted traffic signal controller.

3.5.8.1 TS 2 Cabinet Assembly

This specification describes the minimum acceptable requirements for a TS 2 Type 1 cabinet assembly to house a NEMA TS 2 Type 1 or 2070L solid-state full- actuated traffic signal controller. The assembly shall include the cabinet, flasher, detector card rack, bus user interfaces (BUIs) to fill all positions, shelf-mount power supply, and six flash transfer relays. For cabinet assemblies of Configuration #3 (12-position), the assembly shall include eight load switches and eight load switch jumpers. For cabinet assemblies of Configuration #4 (16-position), the assembly shall include ten load switches and eight load switch jumpers.

3.5.8.2 Cabinet Design Requirements

1. The cabinet shall be constructed using unpainted sheet aluminum on the outside with a minimum thickness of 3.2 mm. Inside of the cabinet shall be painted gloss white. No wood, wood fiber products, or other flammable material shall be used in the cabinet. All continuous welds shall be neat and of uniform consistency.
2. The size of the cabinet shall be Size 5 (as modified in the table below) or Size 6 as defined by TS 2 of the NEMA Standard Publication TS 2 – 1992, as specified by the plans. The load bay shall be configuration 3 (12 position)

or configuration 4 (16 position) as defined by TS 2 of the NEMA Standard Publication TS 2 - 1992, as specified by the plans. The vehicle detector rack shall be Configuration #1 or Configuration #2 as defined by TS 2 of the NEMA Standard Publication TS 2 – 1992.

Cabinet Options	Size of Cabinet	Back panel Configuration – Size of Load Bay	Detector Rack Size
Option 1	Pole Mount – TS2-1 Size 5 Modified (50”H x 30” W x 17” D) (no generator transfer switch)	Type 1 Configuration # 3 12-position (1-8 vehicle, 9-12 ped) load bay with two BIU rack positions	Configuration #1 with 8-position 2-channel and one BIU rack position
Option 2	Base Mount –TS2-1 Size 5 Modified (54”H x 36” W x 17” D)	Type 1 Configuration # 3 12-position (1-8 vehicle, 9-12 ped) load bay with two BIU rack positions	Configuration #1 with 8-position 2-channel and one BIU rack position
Option 3	Base Mount – Size 6 (55”H x 44” W x 26” D)	Type 1 Configuration # 4 16-position (1-8 vehicle, 9-12 ped, 13-16 overlap) load bay with two BIU rack positions	Configuration #2 with 8-position 4-channel and two BIU rack positions

1. Vertical shelf support channels shall be provided to permit adjustment of shelf location in the field. The channels shall have a single continuous slot to allow shelves to be placed at any height within the cabinet. Channels with fixed notches or holes are not acceptable.
2. Each cabinet shall be equipped with an extra set of Unistrut channels either side of the front section of the cabinet to permit the purchaser to mount additional equipment as necessary.
3. Shelves shall be at least 330 mm deep and be located in the cabinet to provide a minimum 25 mm clearance between the back of the shelf and the back of the cabinet. A 38-mm minimum height drawer shall be provided in the cabinet, mounted directly beneath the bottom shelf. The top shelf shall be vented with slots so that air can pass through this shelf. The drawer shall have a hinged top cover and shall be capable of storing documents and miscellaneous equipment. This drawer shall support to 22.5 kg in weight when fully extended. The drawer shall open and close smoothly. Drawer dimensions shall make maximum use of available depth offered by the controller shelf and be a minimum of 600 mm. Drawer must be positioned so that it does not hinder the ability to work on, remove or access any other component in the cabinet.
4. Two shelves shall be provided in the cabinet and shall be at minimum 305 mm apart in height. There shall be sufficient shelf space to accommodate a controller unit 330 mm high, an MMU, one 8-position card rack and external

power supply. An additional space at least 305 mm high, 325 mm wide, and 305 mm deep shall be provided. The shelves shall be placed in such a manner that sufficient ventilation is provided to all electrical components and full access is provided for installation, removal, and maintenance of all internal components from both front door and back door.

3. The cabinet shall be vented and cooled by two thermostatically controlled fans. The fans shall be a commercially available model with a capacity of at least 2.7 m³/min. The thermostats shall have a minimum adjustable range of 70°F to 110°F and shall be preset to turn on at 95°F.
4. The cabinet shall be provided with a unique serial number with date of manufacture that shall be stamped directly on the cabinet or engraved on a metal or metalized mylar plate epoxied to the cabinet. The digits shall be at least 5 mm in height and located on the upper right sidewall of the cabinet near the front.
5. All labeling inside of the cabinet shall be black and shall not be blocked by wiring or internal components.

3.5.8.3 Cabinet Door

The cabinet shall be provided with one door in front that will provide access inside the cabinet. The door shall be provided with a full-length piano hinge with stainless steel pins spot welded at the top of the hinge. The hinges shall be mounted so that it is not possible to remove them from the door or cabinet without first opening the door. The bottom of the door opening shall extend at least to the bottom level of the back panel. The door and hinges shall be braced to withstand a 74 kg per vertical meter of door height load applied to the outer edge of the door standing open. There shall be no permanent deformation or impairment of any of the door or the cabinet body when the load (referenced above) is removed.

An additional back door shall be provided with all base-mounted cabinets. The front door specification shall apply to all back-door applications with the exception of an auxiliary police door.

1. The cabinet door shall be fitted with a Number 2 Corbin lock and a stainless- steel handle with a 16 mm (minimum) diameter shaft (or equivalent cross- sectional area for a square shaft) and a three-point latch. The lock and latch design shall be such that the handle cannot be released until the lock is released. Two keys shall be provided for each cabinet. A gasket shall be provided to act as a permanent dust and weather resistant seal at the controller
2. cabinet door facing. The gasket material shall be of a nonabsorbent material and shall maintain its resiliency after long-term exposure to the outdoor environment. The gasket shall have a minimum thickness of 6.25 mm. The gasket shall be located in a channel provided on the cabinet or on the door(s). An “L” bracket is acceptable in lieu of this channel if the gasket is fitted snugly against the bracket to insure a uniform dust and weather resistant seal around the entire door facing. Any other method is subject to purchaser approval during inspection of an order.

3. A locking auxiliary police door shall be provided in the door of the cabinet to provide access to a panel that shall contain a signal shutdown switch, a signal flash switch, a manual-automatic switch, and a manual advance push-button switch on a six-foot pluggable/removable, retractable cord. Manual control of the controller unit from the police door shall override any external control (external logic, etc.) in effect when the Manual-Automatic switch is in the manual position. Each actuation of the manual advance push-button switch shall advance the controller to the next interval. Manual control shall not override any calls for preemption. The police door shall be gasketed to prevent entry of moisture or dust and the lock shall be provided with one brass key. Switches shall be labeled for each operation.
4. The intake for the vent system shall be filtered with a permanent air filter. The filter should consist of a removable metal frame, 14x20x1 inch thick with replaceable fiberglass mesh filter. The filter shall be securely mounted so that any air entering the cabinet must pass through the filter. The cabinet opening for intake of air shall be large enough to use the entire filter. The air intake and exhaust vent shall be screened to prevent entry of insects. The screen shall have opening no larger than 8.1 mm². The total free air opening of the exhaust vent shall be large enough to prevent excessive backpressure on the fan.

3.5.8.4 Wiring

All wiring within the cabinet shall be neat and routed such that opening and closing the door or raising or lowering the back panel will not twist or crimp the wiring. All wiring harnesses shall be either sheathed in nylon mesh sleeving or jacketed with PVC or polyethylene insulation. Wiring leading to the cabinet door shall be sheathed in nylon mesh sleeving or be PVC jacketed cable only. All SDLC cabling shall be Belden #7203A or equivalent.

A. Size

1. All conductors between the main power circuit breakers and the signal power bus shall be a minimum size 10 AWG stranded copper. All conductors carrying individual signal lamp current shall be a minimum size 16 AWG stranded copper. All AC service lines shall be of sufficient size to carry the maximum current of the circuit or circuits they are provided for. Minimum cabinet conductor wire size shall be 22 AWG stranded copper. All wiring and insulation shall be rated for 600 V or greater.
2. Conductors for AC common shall be white. Conductors for equipment grounding shall be green. All other conductors shall be a color different than the foregoing.
3. No P.C. boards will be allowed on the back panel of the cabinet. All wiring must be done from the BIUs to the Load Switches using standard 19-gauge wiring.
4. Conflict monitor wires shall be colored as to correspond with the output being monitored (example: green wire for green output, yellow wire for yellow output, and red wire for red output) or labeled to identify the output that is being monitored.

- B. A barrier terminal block with a minimum of three compression fitting terminals designed to accept up to a #4 AWG stranded wire shall be provided for connection of the AC power lines. The block shall be rated at 50 Amperes.
- C. All terminals shall be permanently identified in accordance with the cabinet wiring diagram using an anodized silk screening process on the aluminum panel. Where through-panel solder lugs or other suitable connectors are used, both sides of the panel shall have the terminals properly identified. Identification shall be placed as close to the terminal strip as possible.
 - 1. All controller input and output function shall be distinctly identified with no obstructions, at each terminal point in the cabinet, with both a number and the function designation. The same identification must be used consistently on the cabinet wiring diagrams.
 - 2. Each load switch socket shall be identified by phase number, overlap number, and pedestrian phase number as applicable. No cabinet equipment, including the load switches themselves, may obstruct these identifications.
 - 3. Each flash transfer base and power relay base shall be properly identified with no possible obstruction.
 - 4. Each harness within the cabinet shall be distinctly identified by function on the connector end.
 - 5. The flasher socket shall be distinctly identified with no possible obstruction.
 - 6. All other sockets needed within the cabinet to fulfill the minimum requirements of the Invitation to Bid, or attachments thereof, shall be distinctly identified.
- D. The ten-pin controller unit harness (A plug Type 1) shall be long enough to reach any point 600 mm above the controller shelf. The A plug Type 1 and the SDLC cable for the controller shall come from the back of the shelf for use with 2070 controller. The A plug and SDLC cable shall be placed in such a way that the 2070 controller will be on the top shelf. The conflict monitor harness and any required auxiliary harness shall reach 600 mm from the conflict monitor shelf.

The conflict monitor harness and SDLC cable shall be placed in such a way that the conflict monitor will be on the top shelf.

- E. Copper bus bars shall be provided for both the power supply neutral (common) and chassis ground. Each bus bar must provide a minimum of ten unused terminals with 8-32 X 5/16" or larger screws. All copper bus bar screw heads shall be accessible with a screw driver. Wires shall enter the bus bars from the bottom and the screw heads shall be accessed horizontally.

Copper bus bars shall be located at the bottom of the detector panel, below the load bay, and near the barrier terminal block mentioned in section 1.4.3 for chassis ground. Tie all ground bar connections in a single loop with #6 AWG wire. Bond detector racks and any panels mounted with uni-struts to the grounding loop. Uni-struts are not acceptable as ground conductors.

Copper bus bars Copper bus bars shall be located below the load bay for AC neutral. The AC neutral and chassis ground buses shall be tied together with a removable jumper that is a minimum #10 AWG wire.

- F. A 20 Ampere and a 50 Ampere thermal type circuit breaker shall be mounted and wired in the cabinet. The 20-ampere breaker shall protect the base light, trouble light, GFCI receptacle, modem duplex receptacles, and fans. The 20 Ampere breaker shall be powered from the 50 Ampere breaker. The 50- ampere breaker shall protect the signal load circuits, controller circuits, conflict monitor, flasher, and card rack detector power supply.
- G. The circuit breakers shall be equipped with solderless connectors and installed on the right-side wall (facing the cabinet) or lower right-hand side of the back panel inside the cabinet. The breakers shall be easily accessible. The breakers shall be positioned so that the rating markings are visible.
- H. A Ground Fault Circuit Interruption (GFCI) type duplex receptacle shall be mounted and wired in the lower right-side wall of the cabinet. Four additional duplex receptacles (for use with communications modems) shall be mounted and wired; two in the upper left side of the cabinet and two in the upper right. These receptacles shall be wired on the load side of the 20 Amp circuit breaker. These receptacles shall be easily accessible and unobstructed by any other components.
- I. The load side of the main circuit breaker shall be protected by a primary and secondary surge suppressor, the Atlantic Scientific Zone Defender Pro (#16700) and Atlantic Scientific Zone Guardian TS (#41003), or engineer approved equivalent.
- J. The suppresser shall be connected to the line filter as recommended by the manufacturer. Number 10 AWG or larger wire shall be used for connections to the suppressor, line filter and load switch bus.
- K. An LED light and door switch shall be installed in the cabinet and placed in such a way that it illuminates the entire cabinet. This light shall be turned on when the cabinet door is opened, and turn off when the cabinet door is closed. A metal oxide varistor (MOV) or other such transient suppression device shall be placed across the AC power input to the light.
- L. A radio frequency interference (RFI) suppresser (line filter) shall be provided and installed on the load side of the signal circuit breaker and shall be protected by the surge protector. This filter shall be rated at 50 amperes and shall provide a minimum attenuation of 50 decibels over the frequency range of 200 Kilohertz to 75 Megahertz.
- M. Transient suppression devices shall be placed on the coil side of all relays in the cabinet. DC relay coils shall have, as a minimum, a reversed biased diode across the coil. AC relays shall have MOV's or equivalent suppression across their coils. RC networks are acceptable. One suppression device shall be supplied for each relay.
- N. Except where soldered, all wires shall be provided with lugs or other approved terminal fittings for attachment to binding posts. Insulation parts and wire insulation shall be insulated for a minimum of 600 volts.

- O. The outgoing traffic control signal circuits shall be of the same polarity as the line side of the power source.
- P. Two switches shall be provided on the inside face of the cabinet door that shall be labeled Test Normal-Flash and Controller On-Off. When the Test switch is in the Flash position, call for flashing operation shall transfer the traffic signal circuits from the outputs of the load switch to the output(s) of a flasher relay. When the Test switch is in the Normal position, the call for flashing operation shall permit the controller unit to continue to run so that its normal operation can be observed. The Controller On-Off switch (located near the Test Normal-Flash switch) will cause the controller unit and any auxiliary equipment to be deactivated. The Test and Controller switches should have some type of guard to protect against accidental activation. There should be ample clearance provided between switch guard and controller face when door is closed.
- Q. The cabinet shall be wired so that activation of the conflict monitor will cause the controller unit, and any auxiliary equipment, to stop timing.
- R. Conflict and manual flash for vehicle and overlap phases shall be prewired for all red flash.
- S. The cabinet shall be designed and equipped with eight transfer relay positions for the 16-position cabinet and six transfer relays for the 12-position cabinet. The purchaser should be able to change flash color using simple tools to move the wires. Wires for the flash circuit shall be color coded for each output of the corresponding channel (example: green for green output, yellow for yellow output, and red for red output). Between the back plane and load bay terminals, flash circuit wires and conflict monitor wires for each channel will be isolated by channel and not bundled or tie wrapped with any other wires. The flash circuit shall be easy to change without having to remove any components (example: load switch or transfer relay). Flash circuit shall be easily accessible and free of any obstructions.
- T. Transfer relays shall be the plug-in type manufactured by Reno A&E (Part No. TR-200) or Struthers-Dunn (Part No. 21XBXPL), or equivalent with LED indication. The relays shall have contacts a minimum of 3/8" diameter in size and shall be rated at a minimum of 30 Amps 102/240 VAC, 20 Amps 28 VDC.
- U. A 75 Amp, solid-state relay shall be wired between the RFI filter output and the load switch power bus. The relay shall be controlled by the signal shutdown switch and the flash switch. The relay shall be mounted to a heat sink designed to allow maximum current flow at 74 C without damaging the relay.
- V. All exposed AC wiring points, including the RFI filter, surge suppresser, and solid-state relay shall be covered with a clear non-conductive plastic cover mounted to prevent accidental contact. Unless otherwise noted in this specification, wiring at terminal strips is exempt from this requirement.
- W. The load switch outputs shall be brought out to posted 10-32 X 5/16" binder head screw terminals. An MOV or approved equivalent suppression device shall be installed on each load switch output. These devices shall be located on the front side of the load bay for easy access and replacement. Field wiring for the signal heads shall be connected at this terminal strip. Compression connections are not

acceptable. All terminal strips for PEDs, overlaps, and vehicle phases shall all be placed on the same plane, horizontally at the bottom of the load bay.

- X. An SDLC Hub Assembly shall include a minimum of eight D-Subminiature Female 15 pin (DB15) connectors that are wired in series. Provide one (1) extra SDLC cable capable of reaching both shelves.

3.5.8.5 Detector Panel and Card Rack

The cabinet shall have a loop detector panel mounted on the left side of the cabinet. This panel shall provide for all connections between loops at the street and the detector cards as described in the following sections.

A. Detector Card Rack

1. The vehicle detector card rack for the Size 5 Modified (12-position back panel) cabinets shall be TS 2 detector rack Configuration #1 and shall accommodate a minimum of eight 2-channel or four 4-channel TS 2 detector units, one BIU and two additional slots for rack mount optical preemption wired 4-channel dominate. The vehicle detector card rack the Size 6 (16-position back panel) cabinet shall be TS 2 detector rack Configuration #2 and shall accommodate a minimum of eight 4-channel TS 2 detector units, two BIUs and two additional slots for rack mount optical preemption wired 4-channel dominate. Bond detector rack to the grounding loop.
2. The detector card rack shall have a rigid frame with labels and shall be fabricated from aluminum and shall have slots set in a modular fashion such that the detector card edge connectors shall plug into a socket while sliding between top and bottom card guides for each module. Mounting flanges shall be provided and be turned outward for ease of access. The detector card rack shall be bolted to a cabinet shelf. It shall be possible to unbolt the rack using simple tools. Wiring harnesses to the detector rack shall have connections that are pluggable and do not require any soldering or de-soldering to change out the detector rack.
3. All wiring to the rack shall be labeled and neatly run to other parts of the cabinet and detector termination panel.
4. The slots shall be numbered 1 to 8, left to right when viewed from the front of the rack. A flange shall be provided on the top and the bottom of the rack to label each individual channel.
5. The detector DC supply shall be bussed to a common point and wired to the detector panel.
6. The chassis ground shall be bussed to a common point and wired to the detector panel.
7. The logic ground shall be bussed to a common point and wired to the detector panel.
8. The data address for the detector BIUs shall be according to TS 2.

B. Detector Panel

1. The Detector Panel shall provide all connections between the detector loops and the detector cards. All detector loop input connections shall be easily accessible and free of any obstructions.
2. The panel shall be constructed of 3.2 mm aluminum.
3. The panel shall contain a 76-mm horizontal slot in each corner to accommodate 6.3 mm mounting bolts.
4. All inputs from the loops shall be brought through posted 10-32 X 5/16" binder screw terminals or 8-32 X 5/16" binder screw terminals.
5. Each loop pair shall be protected by lightning surge suppresser. The suppressers must be easily accessible and mounted so that they can be replaced without removing the detector panel. Suppressers shall not obstruct terminal strips making it difficult to connect loops.
6. Each detector will have a test switch such that when the switch is closed, a call is placed upon that detector input. The test switch will have three positions; no effect, permanently on, and momentarily on.
7. The detector panel for cabinet Configurations #1, #2 and #3 (12-position) shall provide the following connection points as a minimum for sixteen (16) detectors:

CONNECTION POINT	NO. OF CONNECTION POINTS
External 24V Power Supply	1
Loop Inputs	16
Logic Ground	1
Spares	6
Chassis Ground Bus	1 Bus

8. The detector panel for cabinet Configuration #4 (16-position) shall provide the following connection points as a minimum for thirty-two 32 detectors:

CONNECTION POINT	NO. OF CONNECTION POINTS
External 24V Power Supply	1
Loop Inputs	32
Logic Ground	1
Spares	6
Chassis Ground Bus	1 Bus

9. A chassis ground bus bar shall be provided on the panel and connected to the cabinet by a copper ground strap. The strap shall be bonded to the grounding loop.
10. The cabinet shall be wired and labeled for eight (8) pedestrian pushbutton inputs. The detector panel shall have all eight (8) pedestrian test pushbutton inputs.
11. Cabinet shall have replaceable pedestrian pushbutton isolator PCB that isolates all eight inputs. These shall be able to be replaced without removal of existing equipment and without putting the intersection

into FLASH.

C. Preempt Panel

1. A preempt panel shall be provided that contains all interface circuits and wiring for preemption and communication functions. The panel shall be located on the left side of the cabinet interior. Bond panel to grounding loop.
2. Three momentary test switches, one for each preempt circuit, shall be provided on the preempt panel. The operator shall not be exposed to hazardous voltages during operation of the test switches.
3. All necessary interconnection cables, relays and mounting hardware shall be provided.
4. There shall be a switch on the preempt/communication panel, which shall release the local controller to operate in an isolated, full-actuated manner, when necessary for maintenance purposes. The switch positions shall be labeled "SYSTEM" and "FREE".
5. Preempt Panel shall have a 12-volt AC relay prewired for preempt input 1.
6. All inputs and terminals shall be labeled.

D. Power Supply

1. The power supply shall be a shelf mounted, enclosed, 24 VDC power supply in accordance to Clause 5.3.5 of the NEMA Standards Publication TS 2-1992.
2. One power supply cable per power supply shall be furnished and installed in each cabinet. The wires shall be terminated to bus bars, terminals on the front of the back panel, detector panels, or connector as appropriate. The connections shall be with forked spade lugs or otherwise as needed. Each individual wire shall be cut to the length required to reach the point at which it is to be connected.

E. Two Circuit Solid State Flasher

1. The solid state, two-circuit flasher shall meet the electrical and physical characteristics described in Clause 6.3 of the NEMA Standards Publication TS 2-1992. The flasher shall be Type III (dual circuit rated at 15 Amps per circuit) unit and so constructed that each component may be readily replaced if needed.
2. The two-circuit flasher shall be of solid-state design with LED indicator lights for each circuit and shall contain no electro-mechanical devices.

F. Load Switches

1. The solid-state load switches shall meet the requirements set forth in Clause 6.2 of the NEMA Standards Publication TS 2-1992, and shall be "Triple-Signal Load Switch" type. Load switches shall be PDC model SSS-86 I/O load switch with LED on front, or equivalent.

2. An indicator light for each circuit shall be provided in each load switch. The indicator light shall be on when a "Low Voltage Active" input to the load switch is present as well as high voltage output.

G. Generator Transfer Switch

1. The base mount cabinets shall contain an internal generator plug accessible from the outside by locking auxiliary door. The auxiliary door shall be gasketed to prevent entry of moisture or dust. The switch must be equipped with a Cooper CWL530P male generator plug. During a power outage, the transfer switch will isolate the emergency circuits from the utility line allowing for efficient operation of the cabinet and generator without back feeding onto the utility. The generator plug and transfer switch shall be mounted below the lowest shelf so as not to block usable space on shelves or block access to any equipment in the cabinet including copper bus bars.

3.5.9 School Zone Warning Signals (Solar & Ac Power):

This Contractor shall furnish all necessary equipment and components as hereinafter detailed for a complete and functional signal. Signals may be AC powered or solar powered.

3.5.9.1 Power

1. Each school zone warning signal shall be furnished complete with solar panel(s) or 120 VAC power.
2. If supplied with solar panels, the solar panels shall consist of vandal resistant, ultra-violet stabilized, 40 watt, silicon solar modules and glass laminated face with an anodized aluminum frame. The solar modules shall have a peak output voltage of 19.0 volts DC under standard test conditions of 1000W/m² at 25°C.
3. Integral bypass diodes shall be included in each cell to allow the modules to produce power when partially shaded.
4. Minimum recovery time shall be three (3) hours in optimum sun conditions.
5. The solar panel shall have a minimum twenty (20) year output warranty.
6. The solar panel shall be complete with a weatherproof junction box providing wire termination for #14 AWG conductors.

3.5.9.2 Battery Bank

Each solar school zone warning signal shall be furnished complete with a battery bank. The battery bank shall consist of two (2) Group 29 sealed maintenance free, deep cycle, gel lead acid type, 12VDC batteries

1. The batteries shall provide for a minimum of twelve (12) days of no sun operation based upon five (5) hours of operation at 78 degrees ambient cell temperature.
2. The batteries shall be housed in a separate pole mounted weatherproof NEMA 3R ventilated aluminum enclosure .125 inches thick complete with a gasketed door and a standard traffic/police type lock and continuous piano hinge. The enclosure shall be mounted to the pole as detailed on the Drawings.

3.5.9.3 Controls

Each school zone warning signal shall be furnished complete with a NEMA 3R ventilated enclosure to house the control electronics supplied by and installed by the City. All control electronics shall be mounted in a removable sub-assembly.

3.5.9.3.1 Control Circuit Sub Assembly

- A. The subassembly shall be equipped with a means for mounting to a suitable back plate. Mounting holes that provide clearance for at least a No. 10 screw will be acceptable.
- B. The subassembly shall provide enough space for the following: A space not to exceed 8 3/8"h x 4 7/8"w x 2"d without harness and 10 3/8"h x 4 7/8"w x 2"d with harness for the City installed time switch. A case shall be provided to protect the time switch circuitry from dust. The unit shall fasten securely to the case and must be easily removable from the case with the use of simple tools. A space at least as large as 3"W x 4"H x 2"D to accommodate the City installed M2M modem.
- C. Interface to the power source (AC or DC) and to the controlled device shall be provided by means of a quick disconnect connector with a mating harness or a terminal block. The AC and DC power inputs shall be protected with a fuse and M

3.5.9.3.2 Integrated Solid State Flasher and System Diagnostic Hardware

- A. A two (2) circuit 12VDC flasher shall be integral to the flasher and diagnostic interface board. The flasher shall be of all solid- state construction and shall be rated at a minimum of 6.0 Amps per circuit. The flasher shall utilize zero-voltage turn-on and turn-off of current thus eliminating electromagnetic interference.
- B. The flasher and interface board shall have two terminal blocks for connecting the wiring of the cabinet. Barrier type terminal blocks shall be used to terminate all wires. The terminal blocks shall terminate the following functions:

TB-1	TB-2
LD-	Solar Panel +
Door	Solar Panel -
Time Switch Normally Open	Battery +
Time Switch Common	Battery -
DC + Power To Time Switch	Load
DC – To Time Switch	Load
	Load
	Conf
	LED 2
	LED 1

- C. The above functions shall be clearly and permanently identified on the circuit board adjacent to the appropriate terminal.
- D. The flasher and interface board shall be pre-wired for connection to a

solar regulator. The wires connecting the flasher and interface board to the solar regulator shall be a minimum of 16AWG and shall be permanently soldered to the flasher and interface board.

- E. The flasher and interface board shall be pre-wired with a 16- position, CPC type, quick disconnect connector to accommodate a time switch.
- F. The flasher and interface board shall include 3 separate fuses to protect the solar array, the battery and the load. The fuses shall be easily replaceable from the front of the board with the use of a standard fuse removal tool.

3.5.9.3.3 A/C System Diagnostic Hardware

- A. Enclosed device with circuit board to monitor LED and Power status.
- B. Color coded wires with a corresponding legend on the face of the unit for easy integration to the cabinet.

3.5.9.3.4 Alerts and Reports

- A. The flasher shall continuously monitor the following functions of the flasher cabinet assembly:
 - i. Solar Panel Voltage: The flasher shall monitor the solar panel voltage every 15 minutes and chart this information. This chart when reviewed by agency personnel will illustrate anomalies or drops in solar panel charging that may indicate a malfunction.
 - ii. Battery Voltage: The flasher shall monitor the voltage of the battery that supplies power to the flasher cabinet every 15 minutes and chart this information. The flasher shall send an immediate alert to the central computer should the battery voltage fall below the level pre-set by the end user.

3.5.9.3.5 Solar Regulator Load

- A. The shall monitor the load output of the solar regulator and shall send an immediate alert to the central computer when the load has been disconnected.

3.5.9.3.6 Primary Flasher Outputs

- A. The flasher shall monitor both of the primary flasher outputs independently and send an immediate alert to the central computer when an indicator failure is detected.

3.5.9.3.7 Confirmation Output

- A. The flasher shall monitor the confirmation light output and send an immediate alert to the central computer when an indicator failure is detected.

3.5.9.3.8 Time Switch Operation

- A. The flasher shall monitor the low voltage of the time switch in the flasher cabinet and send an immediate alert to the central computer when a time switch failure is detected.

3.5.9.3.9 Door Open/Closed

- A. The flasher shall have the capability of monitoring the position of the cabinet door. If this option is used, the flasher shall send an immediate alert to the central computer when the cabinet door is opened and when the cabinet door is closed.

3.5.9.3.10 Loss of Battery Power

- A. The flasher shall have the capability of sending an immediate alert to the central computer when the battery is disconnected due to maintenance or theft. The flasher shall maintain power to the cell modem long enough to send the alert when the battery is removed.

3.5.9.3.11 Warranty

- A. Each unit shall be warranted to be free from defects in material and workmanship for a period of five years from the date of shipment from the factory.
- B. Any warranty service required shall be promptly performed at the manufacturer's facility or the manufacturer's authorized service agency. The purchaser will pay transportation costs to such service point, and the manufacturer will pay those costs to return the unit by normal surface transportation means.
- C. The control electronics shall be housed in a separate pole mounted weatherproof NEMA 3R aluminum enclosure .125 inches thick complete with a gasketed door and a standard traffic/police type lock and continuous piano hinge. The enclosure shall be mounted to the pole above the battery enclosure as detailed on the Drawings.

3.5.9.3.12 Signal Beacons

- A. The school zone warning signal shall be furnished complete with two (2) twelve (12") inch diameter LED type signal beacons as detailed on the Drawings. Each signal beacon shall have: a one-piece aluminum body; one-piece aluminum cutaway visor attached at four (4) points to a one-piece aluminum door; terminal block, UL Type 1015, 600 volt, color coded wiring; and solid state LED amber lamp elements suitable for operation on 12 VDC as described below. The door shall have stainless steel hinge pins and thread lock hex-head screws. The signal beacons shall be the Virginia Department of Transportation (VDOT) Type VR-6 only.
- B. The LED lamp elements shall be high efficiency, solid state amber LED lamps with a size of twelve (12) inches. The lamp shall have optically matched LED elements for uniform color output of 590 nanometers. The amber elements shall contain LED elements constructed from TSiInGaP. Lamps shall incorporate multiple main circuits comprised of four (4) LED's per string and shall be self-regulating with input voltages of 10.5 – 18.0 VDC. The lamp lens shall be either a clear or tinted UV stabilized acrylic which shall be easily removed and replaced. The lens of the lamps shall be designed to have up to 300 collector lenses for each LED with up to 450 exit facets to direct the light to meet a 17.5 degree vertical by 55 degree horizontal beam pattern.

3.5.9.3.13 Sign Face

- A. Each school zone warning signal shall be furnished complete with one (1) sign face, S5-1 as detailed in the Manual of Uniform Traffic Control Devices. The sign face shall be fabricated from .125 inch thick aluminum alloy conforming to ASTM B209, Alloy 5052-H38, 5154-H38, or 6061-T6. The background field shall be reflectorized. The message and borders shall be black. The sign face shall be pole mounted between the LED signal beacons.

3.5.9.3.14 Pole, Base and Foundation

- A. Each school zone warning signal shall be furnished complete with one (1) fifteen (15) foot high, 4-1/2" diameter, 6061-T6 spun aluminum, schedule 40 pole, threaded at one end to NPT #8 specifications. The pole shall be complete with a hot dipped galvanized finish and include an acorn-style pole cap.
- B. The pole shall be complete with a transformer base. The transformer base shall be a square, aluminum base, 15" high and forged to accept a bolt circle corresponding to the bolt circle of the foundation anchor. The neck shall be NPT #8 threaded and come equipped with a set screw to secure the pole to the base. A grounding lug shall be included with the base.
- C. The self-augering pole foundation shall be galvanized and recommended by the manufacturer as appropriate for use with the pole and base. An access hole for installing conduit and a grounding wire into the foundation shaft is required. The access hole provided in the foundation anchor shall facilitate the entry of a 2" conduit into the Auger Base. The top plate of the foundation shall have a bolt circle to match the transformer base. All the hot-dipped galvanized hardware (bolts, nuts, washers and shims) required for the installation of this assembly shall be included as part of this unit. A 10-foot-long, 5/8 inch copper clad ground rod, connected to the ground lug in the transformer base by the required length of #4 AWG solid copper ground wire shall be included.
- D. Examples:
- Pelco 4-inch Diameter PB-5100 Pole 15' length
 - Pelco PB-5335-1S-GL Square Base
 - Pelco PB-5401 Acorn Type Cap
 - PB-5364-GLV Foundation Anchor or equivalent as approved by the Engineer

3.5.10 Traffic Signal Loop Sealant

The loop sealant encapsulates, insulates and protects the wires of a detector loop from the effects of the harsh roadway environment.

3.5.10.1 Manufacturer/Model

1. Pro Seal 6006 and STAT-A-FLEX are the standardized loop sealant currently approved for use by the Charlotte Department of Transportation.

3.5.11 Blank Out Signs

- 3.5.11.1 Comply with FHWA's "Standard Highway Signs and Markings" current edition for use with the MUTCD, current edition.

- 3.5.11.2 Ensure compatibility and proper triggering and operation with load switches and conflict monitors currently used by the City.
- A. Design all interconnections within the sign to be accomplished through the PCB with no internal wiring except for a single cable for the message display and wires form the input terminal block.
 - B. All connectors and terminals shall be identified on the surface of the Circuit Board.
 - C. Design the interconnect PCB to include terminals for all field wiring, 120VAC controls, external photocell, and alarm signals. Include a 30-second delay to prevent interference caused by extraneous light.
 - D. Provide a green LED for power status and a red LED for alarm status and indication for dimming feature on the drive module.
- 3.5.11.3 Display shall consist of an aluminum frame and face lens. Provide a clear, non-glare, matte finish polycarbonate lens with a UV resistant surface treatment.
- 3.5.11.4 LED Light Source
- A. Use LEDs that are evenly distributed. Ensure that the maximum distance, center to center, between consecutive LEDs is 0.5 inches, plus or minus 10%.
 - B. For text-only sign displays, text shall be 6-inch-high Series “E” letters for “NO” and 5-inch-high Series “D” letters for remaining sign message.
 - C. Provide a multi-conductor cable with an individual 2-pin connector for each word.
 - D. Individual LED light sources shall be connected so that failure of a single LED will result in a loss of no more than 5 LEDs; in such case sign shall still legible.
 - E. Protect and seal the LED module and Circuit Board against dust and moisture intrusion.
 - F. LED shall maintain constant drive regardless of outside temperature or conditions.
 - G. Modules shall include both a sensor which will automatically reduce the light intensity on each display by 25% based on ambient light and the ability to manually dim display down to 25%. Both the manual and automatic dimming features should be able to be used simultaneously.
 - H. Shall operate at a temperature range of -35°F to 165°F with an operating voltage range of 105 to 130 volts. Ensure that all electronic components are standard industry items. Provide components that are “solid state” type. Do not use electro-mechanical components such as relays, transformers or solenoids. Power input must include replaceable power supply and surge protection contained within the housing.
- 3.5.11.5 Sign shall be legible so that a person with 20/20 vision can read a fully intensified, legible message from 500 feet in front of the sign as well as at a

25o angle under any light conditions. Ensure the message is not legible when the sign is off, even if in direct sunlight.

3.5.11.6 Can be serviced while installed and/or in use.

- A. Each indication shall have some type of hot swappable modular control.
- B. Design the entire display face and door as a one-piece, self-contained module that can be removed from the housing in less than thirty minutes.

3.5.11.7 Housing shall be constructed with aluminium only.

- A. Mount the module on the sign housing with three stainless steel “lift-off” hinges, and latch it with a minimum of two stainless steel ¼ turn link locks. Provide a retaining rod to hold the door in the open position. Configure the front door frame assembly to cover a gutter surrounding the full perimeter of the housing body and fit flush to the exterior of the body.
- B. Fabricate the weatherproof housing out of 0.125-inch aluminum with all corner seams welded their full length. Weld the full length of all corner seams using tungsten inert gas method. Provide a 1-inch diameter vent plug in four bottom corners of the housing to prevent the collection of water from possible gasket leaks. Ensure each vent plug has a corrosion resistant screen, which allows the passage of water but does not allow insects to enter the housing. Install a terminal block that accommodates a spade lug sized for a number 10 terminal screw. Provide 4 terminals with each having 2 terminal screws that have a shorting bar between them.
- C. Fabricate a mounting fitting and entrance for wires to be compatible with standard traffic signal mounting hardware using Pelco type die cast aluminum mounting hubs with 1.5-inch threaded nipples. Provide stainless steel nuts, bolts, screws, washers, lock washers, etc. Do not use self-tapping fasteners on the exterior of the sign. Ensure that all mechanical fasteners are stainless steel.
- D. Provide a standard sun visor made of 1/16-inch aluminum, with a minimum 7” depth and maximum 12” depth. Paint the inside of the visor with 2 coats of dull black paint. Paint the exterior and interior of the sign case and the outside of the visor dull black by the dry powder method. Apply the finish by electrostatic spray and heat cure. Ensure the thickness of the finish is a minimum of 2.5 mils thick. Do not apply paint to latching hardware.

3.5.11.8 Shall conform to the following sign face (inside) dimensions, with the idealdimension being 24” x 30”.

Dimensions	Minimum	Maximum
Width	24”	30”
Height	30”	36”

- 3.5.11.9 All display configurations must include: instructions for installation and how maintenance is performed on the unit, including notes on special equipment or procedures needed and how the unit can be serviced while in use.
- 3.5.11.10 All display configurations must be accompanied by a product specification sheet.
- 3.5.11.11 All display configurations must be accompanied by a five-year warranty statement and guarantee the materials and workmanship of all equipment provided under this section for a period of five year. All warranties and guarantees that are customarily issued by the equipment manufacturers that exceed this requirement will be acceptable to the Department. Begin the warranty period on the date of the final acceptance of all work if contractor supplied, or on the date of installation if supplied to the Department by a manufacturer or manufacturer's representative. Guarantee all parts and labor necessary or incidental to the repair of any defect in equipment or workmanship and malfunctions that arise during the guarantee period. Provide the guarantee to the Department in writing before final acceptance of the work and material. Obtain the Engineer's approval of the guarantee's wording.
- 3.5.11.12 Ensure that the manufacturer's warranties and guarantees delivered to a contractor includes the provision that they are subject to transfer to the Department or its designated maintaining agency, and provide proper validation from the manufacturer. Transfer warranties and guarantees to the Department at the time of acceptance of the work.
- 3.5.11.13 The vendor will provide bench repair training on the manufacturer's equipment as required by the bid document or plans at no additional cost to the City unless otherwise specified. In addition to any formal training requirements, the vendor agrees to provide the following upon request: 1) Prompt technical support to the City personnel during the contract and through the end of the warranty period at no cost to the City; 2) Provide parts to the City for all warranty repairs at no cost to the City (defective parts which are under warranty will be returned to the vendor for examination upon vendor request); 3) Provide schematics and other documentation required to perform bench repair to the City within two weeks of request. Upon request from the vendor, the City agrees not to divulge any proprietary information contained in those documents.
- 3.5.11.14 The vendor will perform warranty repairs to equipment that fails during the warranty period at no cost to the City including freight costs to ship repaired equipment back to the City. The City will pay freight charges to ship equipment to the vendor or manufacturer. Ensure all equipment is repaired and returned to the City within 21 calendar days of receipt by the vendor.
- 3.5.11.15 Hardware:
 - A. When requested by the City, all necessary mounting hardware shall be supplied and installed on each sign to be fixed mounted on a mast arm.

- B. When requested by the City, all necessary mounting hardware shall be supplied and installed on each sign to be mounted under the arm mount of a mast arm.
- C. When requested by the City, all necessary mounting hardware shall be supplied and installed on each sign to be mounted on a span wire, including black powder coat of mounting bracket.
- D. Brackets for all installation types must be adjustable up to 45° angle.

3.5.11.16 The following display configurations must meet the Product Specifications. The City reserves the right to waive variances from these configurations to the extent the City, in its sole discretion, determines that such variances will not materially impact whether the Product meets the City’s needs. The Products received must be of high quality materials.

3.5.11.16. Sample Product Specifications

Bidders shall submit one sample of the blank-out sign listed below. Each sample sign shall meet the specifications listed in Section 3.4.8 in addition to the following:

1. Two-message blank-out sign on a single face shall have three phases:
 - a. “NO TURN ON RED” sign concept as depicted below
 - b. “RIGHT TURN ▼ TO ▲ ” sign concept as depicted below
 - c. Dark
2. White LEDs prefer to be used except for the yield sign symbol which prefer to be red LEDs.
3. Yield sign symbol in red LEDs minimum height shall be ten (10) inches.
4. Each leg of yield sign symbol shall be a minimum of 1.75 inches wide and shall give the appearance of being solid. An outlined symbol shall not be acceptable.
5. Pedestrian symbol minimum height shall be twelve (12) inches.
6. The pedestrian symbol shall give the appearance of being solid. An outlined symbol shall not be acceptable.
7. Spacing between words and symbols in any direction shall be a minimum of two (2) inches.
8. Adhere to the layout and notes for the sign concepts for the first phase and second phase below:

A. First Phase: "NO TURN ON RED"

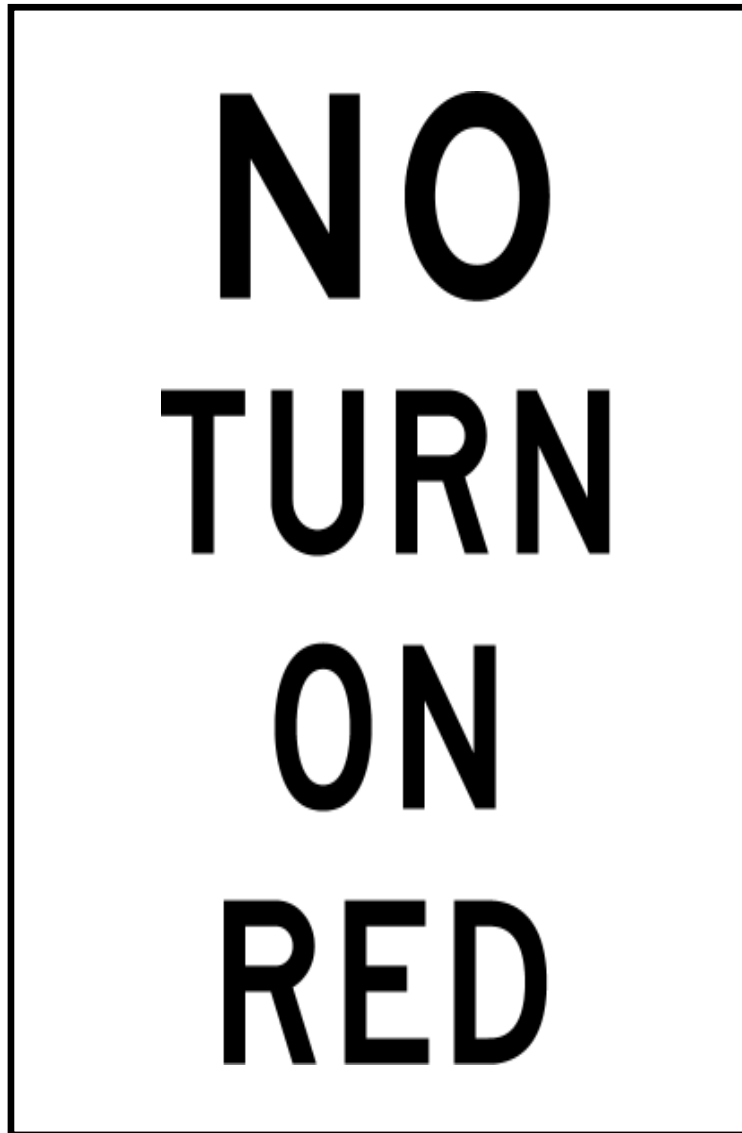

B. Second Phase: “RIGHT TURN ▼TO  ”

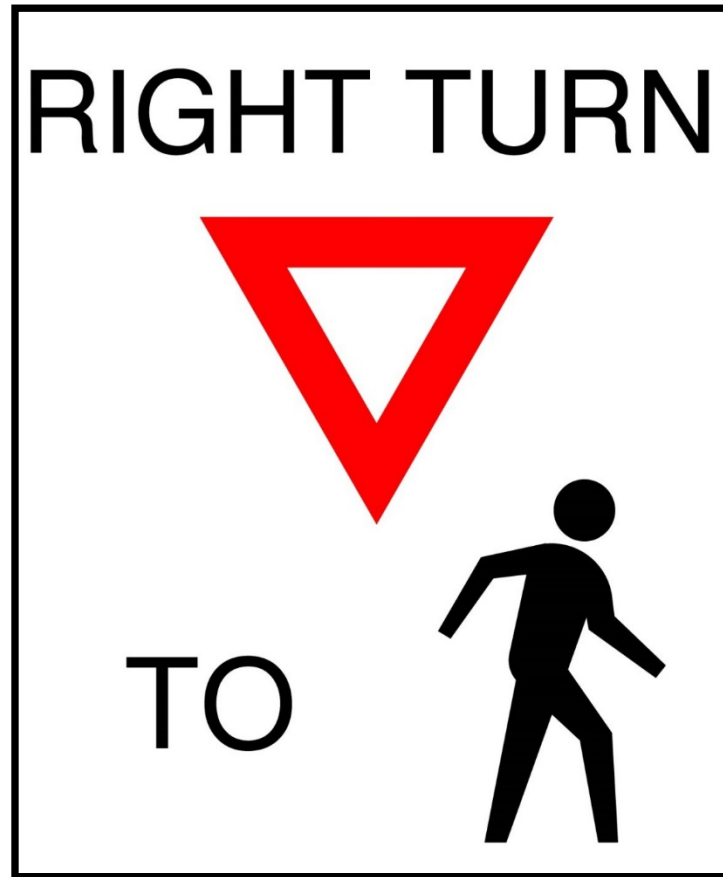

3.6 Product Standards:

It is essential that all Traffic Signal Components be in compliance with the latest industry standards and other laws and requirements concerning Traffic Signal Lighting in the state of North Carolina.

3.7 Alternate Products:

Please refer to Section 1.23 and 1.24 for complete details regarding submittal of Alternate Products.

The City cannot be responsible for testing and or accepting every new or evolving product proposed and reserves the right to reject proposed products that do not meet the City's current business model.

3.8 Warranty:

All Products supplied under the Contract shall be covered by a manufacturer's written guarantee and/or warranty that such Products will be free from defects in materials, workmanship and performance for a minimum of one year; merchantable and in full conformity with the Specifications set forth in this ITB, industry standards, dimension charts and Bidder's descriptions, representations and samples. The Company shall administer the warranty on the City's behalf, and shall ensure that the manufacturer repairs or replaces at no charge to the City all Products that violate either the above warranty or the applicable manufacturer's warranty.

- The Company shall provide the City with two copies of the manufacturer's written warranty for each item of equipment.
- It shall be the responsibility of the manufacturer to pay all shipping and crating costs associated with warranty repairs.

3.9 Installation:

Only experienced professionals should install all products. All work must be performed according to the standards established by the terms, specifications, and drawings and meet manufacturer's specifications and industry standards.

3.10 Pricing:

Bids shall be submitted as a fixed unit price per item that includes shipping and delivery, any discounts, vendor markup/profit, item cost and storage. No other charges are allowed. (modify as needed – could be a lump sum cost or discount off list price).

3.11 Delivery:

(modify as needed) All Products provided under this contract must be delivered F.O.B. Destination within 2 weeks from the placement of order. Workdays are Monday through Friday, excluding recognized City, State and Federal holidays. Delivery and freight charges are to be included in discount price. Failure to comply with this requirement shall be cause to terminate this contract unless such failure is confined to infrequent and isolated instances, which do not involve major purchases.

Each order delivered must have a packing slip enclosed. The packing slip must clearly show the purchase order number, items ordered, unit of measure, contract pricing, items enclosed and identify any items on backorder.

3.12 Delivery Personnel:

All delivery personnel of the successful Bidder may be subject to background checks at the discretion of the City. Bids shall include company policies regarding selection of personnel who will be frequenting City facilities.

3.13 Invoices:

The Company must submit invoices weekly/monthly to the City's Finance department. Invoices must include the item number, description, unit cost, quantity and extended price, and contract or purchase order number of each item purchased. Every invoice must also include the City department that placed the order and be submitted to City of Charlotte Accounts Payable per the billing instructions of the subsequent Contract. Add specific requirements as needed (i.e. electronic billing, etc.)

- It is acknowledged and agreed that having correctly priced invoices is a material element of the proposal to the City. Failure by the Company to submit correct invoices may be grounds for termination of the contract. Without limiting the City's right to terminate the contract for incorrect pricing on invoices, the Company agrees to pay the City a service fee for correcting invoices equal to twenty-five dollars (\$25) for each item incorrectly priced on an invoice. Payment must be in the form of a deduction from other amounts owed to the Company.
- Invoices must include only Products and Services that have been delivered and completed.
- As a condition of payment, the Company must invoice the City for Products and Services within 60 days after such Products and Services are delivered. The Company waives the right to charge the City for any products or services that have

not been invoiced to the City within 60 days after such products or services were delivered.

3.14 Award of Contract:

The City reserves the right to award this contract based on the lowest responsive responsible bidder taking into consideration vendor qualifications and experience, quality, delivery, workmanship and any applicable environmentally preferable attributes associated with the product or services.

The City also reserves the right to award contract(s) by item, combination of items or grand total, whichever is in the best interest of the City.

Multiple awards may be made as a result of this ITB if doing so will ensure that any ensuing contract(s) will allow the City to fulfill current and future requirements or in the best interest of the City.

The City reserves the right to add items excluded under this Invitation to Bid, or to delete items, which are included under this Invitation to Bid.

3.15 City Contracting Requirements:

The City will enter into an Agreement written by the City with the successful Bidder that contains the terms and conditions set forth in this ITB and Sample Contract. Each Bidder must state specifically in its bid response any exceptions to the terms and conditions included in this ITB, or the sample Contract and any proposed additional terms or conditions deemed important by the Bidder. The City will take any such exceptions and proposed additions into account during the evaluation process. Any terms and conditions that the Bidder does not specifically object to will be incorporated into the resultant Agreement. Notwithstanding the foregoing, the City reserves the right to change the proposed contractual terms and conditions prior to contract award if it is in the City's best interest to do so.

The terms and conditions set forth in this ITB are not all inclusive. The City may propose additional terms and conditions based on the responses to this ITB and the City's analysis of the successful bid.

The term "Contract" shall refer to the contract entered into between the City and the successful Bidder, and the term "Company" shall refer to the successful Bidder.

3.16 Items Under Contract:

The City reserves the right to add or delete items to this Contract if particular items should become discontinued or an upgraded item becomes available to the industry market. Any new or replacement items added will be subject to bid statute requirements. The City may also delete Product items included in this Contract if the items are no longer needed by the City.

3.17 Customer Service Representative:

The Company must dedicate a Full-Time "Account Executive" for servicing the City. The account executive must be available by cell phone. The cell phone must be operational at all times. All communicational contact, either via phone, email, etc. must be addressed with a response within two (2) business days. The account executive must be available to attend meetings regarding Product issues upon request. The account executive will be responsible for providing immediate response and quick resolution of all the service issues and complaints of City personnel. The account executive must have an in-depth knowledge of all items provided in this bid and have immediate access to manufacturers providing the Product items. He or she must have the ability and authority to make decisions on behalf of their employer enabling them to provide both normal and emergency service as necessary.

3.18 Permitting Responsibilities:

All permits and inspections are the sole responsibility of the successful Bidder.

3.19 No Limitations on Disclosure.

All Bidders agrees that the City shall be able to disclose and distribute to any persons or entities, without restriction, all Products, samples and other Products provided under in the course of this bid process or under the Contract. The Company specifically agrees that the City can and will provide samples of the Products provided under this Contract to the Company's competitors in any future procurement process.

3.20 City Department Participation:

Other City Departments shall be permitted to purchase Product items defined in this Contract. The Company shall be responsible for obtaining valid identification of such employees, and for verifying that such individuals are employed by the City and are authorized to make such purchases.

3.21 Returns and Restocking Charges:

The Company or applicable manufacturer must pick up any merchandise to be returned within twenty-four (24) hours after the City notifies the Company of the return. The City will not pay restocking fees for merchandise that has been returned unless it is subject to minimum inventory requirements under this ITB or is a specialty item and the City has been notified, at the time of placement of order, of the potential restocking charge. The Company will issue a credit memo to the City within seven (7) calendar days of the return.

3.22 Placement of Orders:

All orders will be placed by City designated personnel on an as needed basis for the quantity required at the time during the term of the Contract. Orders will be placed by means of a purchase order, or other approved authorization method.

3.23 Product Specifications and Or Equal Standard.

Following this page is a list of Products which are described in part by reference to specific brands and style numbers. The brands names and style numbers are listed only for purposes of description and establishing a quality standard. The City will consider alternate products of equal or better quality ("Alternates"), only if the Bidder submits samples of such products for testing and evaluation in compliance with Sections 1.23 and 1.24 of this ITB. Any Alternates that are approved by the City will be listed in an Addendum subsequent to issuance of this ITB.

For each of the Products specified, the City lists factors that will be important considerations in determining whether a proposed Alternate is equal to or better than the named brand in meeting the City's requirements. While the City regards these factors as important, the City reserves the right to waive variances from these requirements to the extent the City determines in its sole discretion that such variances will not materially impact whether the Product meets the City's needs. The important considerations listed for each item are not an exclusive list of factors that will be taken into account in determining whether a proposed Alternate meets the City's requirements. The City will consider any factors the City deems relevant to the performance, durability, appearance, comfort, fit, convenience or maintenance requirements for any proposed Alternate.

PEDESTRIAN SIGNAL HOUSING					
Item No.	Description	Manufacture Name	Manufacturer No.	UOM	Estimated Annual Qty.
1	16" Aluminum Pedestrian Signal	Peek	s000322-4302afy,03,01,01	Each	250
2	Pedestrian Clam Shell Mounting Hardware	Peek	s599976-4805fy cse	Each	250
LED PEDESTRIAN SIGNAL MODULES					
Item No.	Description	Manufacturer Name	Manufacturer No.	UOM	Estimated Annual Qty.
1	16" x 18" LED Pedistrial Signal Module	Dialight	430-6479-801X-NC	Each	250
PEDESTRIAN SIGNALS FOR VISUALLY AND HEARING-IMPAIRED					
Item No.	Description	Manufacturer Name	Manufacturer No.	UOM	Estimated Annual Qty.
1	Special Messages per Crossing	Temple	850-266	Each	20
2	CCU W/USB & Ethernet Port (W/6 Ft. Cable)	Temple	CCU2EN	Each	100
3	4 Wire 5x7 EZ Comm APS Push Button Station	Temple	EN45ANO-X	Each	400
4	Ped Head Control Unit w/12 ft. Interconnect Cable	Temple	PHCU4W	Each	400
5	Ped Head Control Unit (1 per Push Button Station Required) w/12 ft. Cable	Temple	IPHCU3W	Each	100
6	INAV Bluetooth Dongle	Temple	IN-DGL	Each	10
7	Cable Harness Assy	Temple	850-217	Each	50
8	9X12 Audible Push Button Station W/LED (R10-25)	Temple	XAV2E-LED	Each	80
9	Control Unit For XAV2-LED	Temple	XAVCU2	Each	10
10	2 Wire 5X7 IN2 APS Push Button Station	Temple	IN25AN0-X	Each	480
11	ICCU Shelf Model (W/50 PIN CONN,Interconnect Board & PLC Cable)	Temple	ICCU-S	Each	60
3.3.5 TRAFFIC SIGNAL CONTROLLERS					
Item No.	Description	Manufacturer Name	Manufacturer No.	UOM	Est. Annual Qty.
1	NEMA Traffic Signal Controller	Econolite	2070CN - 35300	Each	250
2	1C CPU	Econolite	119-1039-501 ASSY, MODULE, 2070-1C	Each	250
3	Cobalt Traffic Signal Controller	Econolite	COB1112011YYO	Each	100

3.3.6 TRAFFIC SIGNAL CONTROL CABINETS					
Item No.	Description	Manufacturer Name	Manufacturer No.	UOM	Est. Annual Qty.
1	Size 5 Traffic Signal Controller Cabinets (pole mount)	Trafficware Group	70008- TS2CNCPMT-12	Each	50
2	Size 5 Traffic Signal Controller Cabinet (base mount)	Trafficware Group	700008-TS2CNC- BMT-12	Each	100
3	Size 6 Traffic Signal Controller Cabinet (base mount)	Trafficware Group	70006-TS2CNC-12APD	Each	100
4	12" Cabinet Risers	Trafficware Group	1410-0031-12"	Each	200
5	10" M54 Cabinet Risers	Safetran	SK3050P7	Each	100
3.3.7 SCHOOL ZONE WARNING SIGNALS (SOLAR & AC POWER)					
Item No.	Description	Mfg. Name	Manufacturer No.	UOM	Estimated Annual Qty.
1	19 RTC Pager Clock Upgrade to M2M Ready (no modem)	RTC	19 RTC	Each	40
2	M2M Cellular (does not include AP22 time clock)	RTC	M2M	Each	40
3	AP22 Time Clock & Harness (M2M ready) w/Harness, no modem	RTC	AP22	Each	40
4	Solar School Zone Flasher (20 watt) to include: One Battery Cabinet with #2 Lock, U-Bolt, Panel, Flasher & Regulator Assembly 20 watt Solar Panel & Mounting, Gel Cell Battery (2) 12" Poly Signals w lamber LED's & Mounting Hardware 15' Pelco pole, Base, collar & Anchor foundation AP22 Time Clock w/M2M modem	Tapco	20 Watt	Each	5

5	Solar School Zone Flasher {40 watt} to include: One Battery Cabinet with #2 Lock, U-Bolt, Panel, Flasher & Regulator Assembly 1 40 Watt Solar Panel & Gel Cell Battery (2) 12" Poly Signals w lamber LED's & Mounting Hardware 15' Pe/co pole, Base, collar & Anchor foundation AP22 Time Clock w/M2M modem	RTC	40 Watt	Each	8
6	AC School Zone Flasher to include: Flasher Cabinet w 1 Mtg Bracket for 4.5" 0.0. Pole Flasher Panel w NEMA Flasher, Lightening Surrestor, Terminal Block, Flasher Base (2) 12" Poly Signals w lamber LED's & Mounting Hardware 15' Pelco pole, Base collar & Anchor foundation AP22 Time Clock w/M2M modem	RTC	AC School Zone Flasher	Each	8
7	Sealed VRLA, Gel, 12V 97.6AH, Flg, Non-Hazardous Non- Spillable Batteries E31 SLD G	MK Battery	E31 SLD G	Each	4

3.3.8 TRAFFIC SIGNAL LOOP SEALANT

Item No.	Description	Manufacturer Name	Manufacturer Number	UOM	Estimated Annual Qty.
1	Loop Sealant	Pro-Seal	6006	Gallon	4000

3.3.9 BLANK OUT SIGNS

Item No.	Description	Manufacturer Name	Manufacturer Number	UOM	Estimated Annual Qty.
1	No Right/Left Turn - symbol - R3-1/R3-2	Orange Traffic	LSR3-1-2	Each	5
2	No Right/Left Turn, symbol & Train, text	Orange Traffic	LSR3-1-2T	Each	5
3	No Right/Left Turn Across Tracks - text	Orange Traffic	LSNRLTAT	Each	5
4	No Turn on Red - Text - R10-11A	Orange Traffic	LSR10-11-A	Each	5

5	No Left and No U-Turn - symbol - R3-18	Orange Traffic	LSR3-18	Each	5
6	No Turns - text - R3-3	Orange Traffic	LSR3-3	Each	5
7	Light Rail Train - symbol - Fits 16"ped head	Orange Traffic	LRT-16	Each	5
8	Light Rail Train - symbol (Stand alone sign)	Orange Traffic	LSW10-7	Each	5
9	Two message (RT Yield to Ped, text & symbol/No Turn on Red, text)	Orange Traffic	LSYTP-NTOR	Each	10
10	Right turn/Left turn (user choice) Yield to Ped, text & symbol	Orange Traffic	DSPYTP-NTOR	Each	5
11	Single Message Lane Control Symbol Sign	Orange Traffic	LS2838-X	Each	5
12	Two Message Lane Control Symbols Sign	Orange Traffic	LS2838-XX	Each	5
13	Three Message Lane Control Symbols Sign	Orange Traffic	LS2838-XXX	Each	5
14	Double-Sided Lane Control Symbol Sign (1 display/side)	Orange Traffic	RLLS2838-1M	Each	5
15	Double-Sided Lane Control Symbol Sign (up to 2 display/side)	Orange Traffic	RLLS2838-2M	Each	5
16	Double-Sided Lane Control Symbol Sign (up to 3 display/side)	Orange Traffic	RLSS2838-3M	Each	5
Mounting Equipment					
Item No.	Description	Manufacturer Name	Manufacturer Number	UOM	Estimated Annual Qty.
1	All equipment necessary for fixed mount of sign on mast arm	Orange Traffic	AG-0125-3-96-SS	Each	5
2	All equipment necessary for under arm mount of sign on mast arm	Orange Traffic	AG-0125-3-96-SS	Each	5
3	All equipment necessary for span wire mount of sign incl black powder coat of mounting bracket	Orange Traffic	AB-3014-SP	Each	10

Spare Sign Face - Display configurations					
Item No.	Description	Manufacturer Name	Manufacturer Number	UOM	Estimated Annual Qty.
1	No Right/Left Turn - symbol - R3-1/R3-2	Orange Traffic	DSPR3-1-2DSPR3- 1-2T	Each	5
2	No Right/Left Turn, symbol & Train, text	Orange Traffic	DSPR3-1-2T	Each	5
3	No Right/Left Turn Across Tracks - text	Orange Traffic	DSPNRLTAT	Each	5
4	No Turn on Red - Text - R10-11A	Orange Traffic	DSPR10-11A	Each	5
5	No Left and No U-Turn SYMBOL - R3-18	Orange Traffic	DSPR3-18	Each	5
6	No Turns - TEXT - R3-3	Orange Traffic	DSPR3-3	Each	5
7	Light Rail Train - SYMBOL (Stand alone sign)	Orange Traffic	DSPW10-7	Each	5
8	Single Message Lane Control Symbol Sign	Orange Traffic	DSP2838-X	Each	5
9	Two Message Lane Control Symbols Sign	Orange Traffic	DSP2838-XX	Each	5
10	Three Message Lane Control Symbols Sign	Orange Traffic	DSP2838-XXX	Each	5
11	Two message -RT Yield to Ped, text & symbol/No Turn on Red, Text	Orange Traffic	DSPYTP-NTOR	Each	5
Replacement Parts					
Item No.	Description	Manufacturer Name	Manufacturer Number	UOM	Estimated Annual Qty.
1	Visors for all sizes of signs	Orange Traffic	LS-VIS-28.5-B	Each	5
2	Surge suppression	Orange Traffic	PRO100T	Each	5
3	Display drivers	Orange Traffic	DVR-260	Each	50
4	Dimming Sensor	Orange Traffic	COM164	Each	5

3.24 Reporting:

A monthly usage report must be supplied electronically to City Procurement no later than the 10th day of the following month. Reports must be designed in such a manner that the information captured on the purchase request shall also be reflected in the monthly report. The report shall clearly identify all items purchased by each department. Each report shall list all items purchased, the manufacturer's name and part/product number, unit price, quantities and extended price for each item.

Product reports which delineate minority products and recycled products must be submitted to City Procurement on a quarterly basis.