



Charlotte Land Development
Standards Manual
(CLDSM)

Revision N^o. 25
October 1, 2025

Charlotte Land Development Standards Manual (CLDSM)

Purpose Statement

The City of Charlotte ensures that new, improved, and modified infrastructure to be used by the public complies with adopted ordinances, meets technical requirements, and is suitable for City maintenance (where applicable). This manual provides standardized information to be used for design, review, approval, and implementation of construction plans. All design details provided in this manual are approved for use within the City of Charlotte and its extraterritorial jurisdiction unless otherwise noted.

The use of the term “standard” means the most common way to design a given feature, not a minimum performance requirement. Non-standard designs may be proposed, subject to the review and approval of appropriate City staff. The developer or designer must provide the supporting details and rationale that the non-standard design meets or exceeds the intent of the standard design(s).

This manual is frequently used as a design reference for the City’s Capital Improvement Program (CIP) projects to facilitate the design process. CIP projects frequently use a combination of standard and non-standard designs, subject to review by City staff, to best meet the needs of the public infrastructure implementation.

This manual is periodically updated to ensure that the provided standard construction details satisfy the City’s requirements.

CLDSM REVISION LOG

The original effective date of the Charlotte Land Development Standards Manual is December 1, 2006. This log is a description of all standard revisions from that date forward.

REVISION NO.	REVISION DATE	STANDARD NO.	NAME	DESCRIPTION OF REVISION
1	1/1/2008	10.24A	Concrete Sidewalks	Changed cross-slope label to 1/4" per foot
1	1/1/2008	10.24B	Commercial Type II and Residential Drop Curb Type I Driveway with Sidewalk Abutting Curb (2'-6" Curb and Gutter)	Updated driveway width table, adjusted cutfill slope percentages to match other DW details
1	1/1/2008	10.24C	Commercial Type II and Residential Drop Curb Type I Driveway with Sidewalk Abutting Curb (6'X18" Vertical Curb)	Updated driveway width table, adjusted cutfill slope percentages to match other DW details
1	1/1/2008	10.24D	Commercial and Residential Drop Curb Driveway with Sidewalk Abutting Curb	Updated driveway width table
1	1/1/2008	10.25A	Residential Drop Curb Type I (Driveway with Planting Strip (2'-6" Curb and Gutter))	Updated driveway width table
1	1/1/2008	10.25C	Residential Drop Curb Type I (Driveway with Planting Strip (6'X18" Vertical Curb))	Updated driveway width table, removed overprint "std, no"
1	1/1/2008	10.26	Drop Curb Driveway - Monolithic Curb and Sidewalk	Updated driveway width table, adjusted cutfill slope percentages to match other DW details
1	1/1/2008	10.27A	Residential Driveway (Type II Valley Gutter)	Updated driveway width table, adjusted cutfill slope percentages to match other DW details
1	1/1/2008	10.27B	Commercial Type II Driveway For 2'-0" Valley Gutter	New detail
1	1/1/2008	11.07	Typical Local Residential To Local Limited Street Taper	Curb lines adjusted to align across intersection; added note #4
1	1/1/2008	11.01	Local Residential Street Typical Section	Removed "Marshall MK" pavement specifications, intermediate course changed to S9.5B from S9.5A
1	1/1/2008	11.02	Local Residential Typical Ditch Type Street Section	Removed "Marshall MK" pavement specifications, intermediate course changed to S9.5B from S9.5A
1	1/1/2008	11.03	Divided Residential Street Typical Section	Removed "Marshall MK" pavement specifications, intermediate course changed to S9.5B from S9.5A
1	1/1/2008	11.04	Local Limited Residential Street Typical Section	Removed "Marshall MK" pavement specifications, intermediate course changed to S9.5B from S9.5A
1	1/1/2008	11.05	Local Limited Residential Typical Ditch Type Street Section	Removed "Marshall MK" pavement specifications, intermediate course changed to S9.5B from S9.5A
1	1/1/2008	11.06	Residential Collector Street Typical Section	Removed "Marshall MK" pavement specifications, intermediate course changed to S9.5B from S9.5A
1	1/1/2008	11.07	Residential Collector Street Ditch Type Typical Section	Removed "Marshall MK" pavement specifications, intermediate course changed to S9.5B from S9.5A
1	1/1/2008	11.08	Limited Residential Collector Street Type Typical Section	Removed "Marshall MK" pavement specifications, intermediate course changed to S9.5B from S9.5A
1	1/1/2008	11.10	City of Charlotte 45' Local Traditional Neighborhood Development Street	Removed "Marshall MK" pavement specifications, intermediate course changed to S9.5B from S9.5A
1	1/1/2008	11.11	Commercial Street Typical Sections	Removed overprint "std, no"
1	1/1/2008	11.14	Divided Private Street Typical Sections	Removed "Marshall MK" pavement specifications
1	1/1/2008	11.15	Typical Section Improvement Detail NCDOT Thoroughfares	Removed detail from manual
1	1/1/2008	11.18	Residential Hammerhead Detail	Added RW, sidewalk, and planting strip dimensions; added ramps
1	1/1/2008	11.21	Overlaid Residential Cul-De-Sacs with Raised Planter Island	Added back of curb radius dimension for 2'-0" C&G, revised note #2
1	1/1/2008	20.00B	NCDOT Standards Approved For Use in the City of Charlotte and Charlotte ETJ	Fixed 840.04 and 840.05 to list correct standard reference 840.54
1	1/1/2008	20.00C	NCDOT Standards Approved For Use in the City of Charlotte and Charlotte ETJ	Added note regarding wall to 840.45
1	1/1/2008	20.03	Double Brick Catch Basin 15'-30" Pipe	Revised note #1 per NCDOT requirements
1	1/1/2008	20.22	Flared End Section 12" to 72" Pipe	Revised note #1 - previously 20.23A, added 3.1 note on drawing in lieu of H/V column in data book; Minimum concrete PSI in note #3 changed from 4000 to 3600
1	1/1/2008	20.34	Offset Catch Basin	Changed slope of flume under grate from 0.5% to 1/8"
1	1/1/2008	30.00	Special Erosion Control Requirements & Notes	New detail
1	1/1/2008	30.01	Temporary Sediment Trap	New detail
1	1/1/2008	30.02	Gravel and Rip Rap Sediment Basin	Removed detail from manual
1	1/1/2008	30.02A	Skimmer Sediment Basin	New detail
1	1/1/2008	30.02B	Skimmer	New detail
1	1/1/2008	30.03	Sediment Basin	New detail
1	1/1/2008	30.06A	Temporary Silt Fence	Added alternate installation detail; revised filter fabric anchor depth; 24" filter fabric above ground
1	1/1/2008	30.06B	High Hazard Temporary Silt Fence	Removed alternate installation detail; revised filter fabric anchor depth; 24" filter fabric above ground
1	1/1/2008	30.09	Hardware Cloth and Gravel Inlet Protection	New detail
1	1/1/2008	30.12	Gravel and Rip Rap Filter Berm Basin	Added data book; updated volume and surface area requirements; DA < 5 AC
1	1/1/2008	30.19	Buffer Installation	Revised note #3; added note #5
1	1/1/2008	30.20	Embankment Matting Detail	Added notes #2 and #4
1	1/1/2008	40.03	Large and Small Maturing Tree Pit with Grate in Sidewalk (Plan)	Updated pit dimensions per City Arborist
1	1/1/2008	40.03A	Large and Small Maturing Tree Pit with Grate in Sidewalk (Section)	Updated pit dimensions per City Arborist
1	1/1/2008	40.03B	Large and Small Maturing Tree Pit with Grate in Sidewalk (Section)	Updated pit dimensions per City Arborist
1	1/1/2008	40.03C	Large and Small Maturing Tree Pit with Grate in Sidewalk (Section)	Updated pit dimensions per City Arborist
1	1/1/2008	50.06B	Parking Standards (Continued)	Revised note #4 regarding wheelstops
1	1/1/2008	50.11	Storage and Pavement Markings at Roundabouts	Fixed 20' dimension placement behind yield line
REVISION NO.	REVISION DATE	STANDARD NO.	NAME	DESCRIPTION OF REVISION
2	7/1/2008	21.00 - 21.23	2100 Series - "Stormwater BMP Details"	Added new section to manual: 2100 Series - "Stormwater BMP Details" for use with Post-Construction Controls Ordinance, effective July 1, 2008
2	7/1/2008	20.31A/B	Best Management Practices Wet Pond details	These details are no longer needed - they replaced by new details 21.05 through 21.09
2	7/1/2008		Removal of error	Remove the words "and Vert." from Section 18.11 of the Specifications and Special Provision Notes
3	1/30/2009	Text pg 16, 17	Notes and Special Provisions	Revised text regarding posting of bonds; added CDOT Pavement Marking Signs to reference list
3	1/30/2009	10.23	Monolithic Concrete Curb and Sidewalk	Revised dimension "A," added dimension "B"
3	1/30/2009	10.32B	Accessible Ramp Sections without planting strip (2' Curb & Gutter)	Added 6" sidewalk thickness dimension
3	1/30/2009	11.16	City of Charlotte and ETJ Residential Cul-de-sac Detail	Added reference to CLDS #20.28
3	1/30/2009	20.28	Sediment Basin	Added note 5, 8
3	1/30/2009	30.02A	Skimmer Sediment Basin	Clarified Sediment Storage elevation & dimensions at spillway; added note #5 re: H; changed silt to 30.03A
3	1/30/2009	30.03A	Sediment Basin	Clarified Sediment Storage elevation & dimensions at spillway; added note #5 re: H; changed silt to 30.03A
3	1/30/2009	30.03B	General Notes - Sediment Basin	Inadvertently removed during previous revision. Added back in & revised to match NCDENR manual
3	1/30/2009	40.03	Large and Small Maturing Tree Pit with Grate in Sidewalk (Plan)	Added note re: City silt tree grate
3	1/30/2009	40.03A	Large and Small Maturing Tree Pit with Grate in Sidewalk (Section)	Added reference to CLDS #20.28
3	1/30/2009	40.03B	Large and Small Maturing Tree Pit with Grate in Sidewalk (Section)	Added reference to CLDS #20.28
3	1/30/2009	40.03C	Large and Small Maturing Tree Pit with Grate in Sidewalk (Section)	Added reference to CLDS #20.28; added 10' width dimension.
3	1/30/2009	40.06	8' Tree Planting Strip UMUD Only	Added reference to CLDS #20.28
3	1/30/2009	40.08A	Median Greater than 120 Inches, Excavation, Drainage and Backfill	Changed top of planting mix to be a horizontal line; "removed 12" max at center"
3	1/30/2009	40.08B	Median Greater than 120 Inches, Excavation, Drainage and Backfill	Changed top of planting mix to be a horizontal line; "removed 12" max at center"
3	1/30/2009	40.08C	Median Greater than 120 Inches, Excavation, Drainage and Backfill	Changed top of planting mix to be a horizontal line; "removed 12" max at center"
4	7/1/2009	10.34B	Accessible Ramp Sections Monolithic Curb and Sidewalk	Removed stray dimension arrow/typo
4	7/1/2009	10.36B	Culvert Crossings on Residential and Commercial Streets	Added info to note #6 re: clear zone and/or handrail
4	7/1/2009	10.40A	Directional Accessible Ramp with Small/Medium Curb Radii	New Detail
4	7/1/2009	10.40B	Directional Accessible Ramp with Large Curb Radius	New Detail
4	7/1/2009	11.07	Residential Collector Street Ditch Type Street Typical Section	Revised Street Classification System to properly show "Class V"
4	7/1/2009	11.08	Limited Residential Collector Street Typical Section	Revised Street Classification System to properly show "Class V"
4	7/1/2009	11.09	Arterial Street Typical Sections	Revised Street Classification System to properly show "Classes II and IV"
4	7/1/2009	11.12	Divided Commercial Street Typical Section	Revised title of detail for clarity
4	7/1/2009	11.13	Private Street Typical Sections	Revised title of detail for clarity
4	7/1/2009	11.18A	Residential Hammerhead Detail	Changed standard detail number from 11.18 to 11.18A
4	7/1/2009	11.18B	Temporary Turnaround Local Residential Street (Optional)	New Detail
4	7/1/2009	21.00	Bio-retention Plan	Added notes re: vanda-proof locking cap, double hammered hardwood mulch
4	7/1/2009	21.01	Bio-retention Cross-section	Minor adjustments for clarity; added note #7
4	7/1/2009	21.23	Underground Sand Filter	Added notes for clarity and to match BMP Design Manual re: 1" debris screen, 12" gravel around drain
4	7/1/2009	30.06A	Temporary Silt Fence	Removed note #1; adjusted note numbering; adjusted burr depth to 8"; post spacing to 6' Max
4	7/1/2009	30.06B	High Hazard Temporary Silt Fence	Adjusted note #1 to read "twice removed" instead of "five fabric filter"; adjusted burr depth to 8"
4	7/1/2009	50.08A	End of Roadway Marker	Removed (ER-1) from title; added notes 3 & 4, added Connectivity sign 50.08C; added OMA-3 note
4	7/1/2009	50.08B	End of Roadway Marker Guard Rail Clamp Installation	Removed (ER-1) from title and notes
4	7/1/2009	50.08C	Street Connectivity Sign for End-of-Road Barriade	New Detail
4	7/1/2009	50.09C	Parallel Parking Standards	Show reverse curves on curbline with chamfers optional, show 22" min length of pkg space
4	7/1/2009	Text pg 17-21	Notes and Special Provisions	Added List of Approved Plant Species (Trees & Shrubs) to list
REVISION NO.	REVISION DATE	STANDARD NO.	NAME	DESCRIPTION OF REVISION
5	7/1/2010	20.00B	NCDOT Standards for use in City of Charlotte and ETJ	Added reference to 20.05A & B
5	7/1/2010	20.00C	NCDOT Standards for use in City of Charlotte and ETJ	Removed reference to "840.06 Markete Frame and Cover"; does not exist
5	7/1/2010	20.05A	Slab Type Catch Basin 15" Thru 48" Pipe	Added old std detail back in CLDSM to provide details how to build slab type CB with 4" deep MH cover
5	7/1/2010	20.05B	Manhole Ring and Cover for Slab Type Catch Basin	Added old std detail back in CLDSM to provide details how to build slab type CB with 4" deep MH cover
5	7/1/2010	20.28	Sediment Detail	Clarified PVC ratings; add reference to Type CP and SP HOPE. Allow Sched. 40 PVC under roadways
5	7/1/2010	21.00	Bio-retention Plan	Added note regarding Post-Construction Controls Easement (PCCE)
5	7/1/2010	21.01	Bio-retention Cross-section	Added PCCE note; clarified specs for stone curtain, underdrain, cleanouts, tree plantings, amended soil
5	7/1/2010	21.02	Bio-retention Planting Plan	Added note re: small maturing trees in amended soils
5	7/1/2010	21.03	Bio-retention Concrete Curb Spillway	REMOVED
5	7/1/2010	21.06	Wetpond Profile	Added PCCE note; various drafting changes for clarity; moved outlet office to perm. pool elev.
5	7/1/2010	21.08	Wetpond Littoral Shelf and Berm detail	Moved outlet office to perm. pool elev.
5	7/1/2010	21.11	Wetland Profile	Added PCCE note
5	7/1/2010	21.16	Enhanced Grass Swale Details	Added PCCE note
5	7/1/2010	21.17	Grass Channel	Added PCCE note
5	7/1/2010	21.19	Infiltration Trench	Added PCCE note
5	7/1/2010	21.23	Underground Sand Filter	Added PCCE note
5	7/1/2010	30.01	Temporary Sediment Trap	Removed misleading titles "Cross-section" and "Plan View"
5	7/1/2010	50.12	Emergency Vehicle Median Crossover	Added note #1 re: use of "REMOVED" entrance only with CDOT approval
5	7/1/2010	Text pg 4, 5	Section 1.B. "Public Streets"	Removed Min. Stopgap Sign Dist. values; added note
5	7/1/2010	Text pg 9	Section 1.F. "Sidewalks and Driveways"	Added note re: measurement and payment of curb and gutter for drop curb driveways
5	7/1/2010	Text pg 13	Section II.E.4. "Storm Drainage: Standards for Design"	Replace reference to 4" PVC or Metal perf. Pipe to instead reference "subdrains"
REVISION NO.	REVISION DATE	STANDARD NO.	NAME	DESCRIPTION OF REVISION
6	1/1/2011	Text pg 4, 5, 6	Section B. "Standards of Street Design"	Amended design criteria to match USDG
6	1/1/2011	10.26F	Commercial Type IV Driveway Standard	Clarified dimensions on wings
6	1/1/2011	10.27A	Residential Driveway (Type I) For 2'-0" Valley Gutter	Added 4x4 wings; adjusted driveway width table to account for wings
6	1/1/2011	11.16	Residential Cul-de-Sac Detail	Removed SW around bulb; removed short C-D-S; removed notes #1 & 6; added #4
6	1/1/2011	11.17	Office / Commercial / Industrial Cul-de-sac Detail	Adjusted Right-of-way outward to accommodate larger planting strip and sidewalk
6	1/1/2011	11.18A	Residential Hammerhead Detail	Removed SW around bulb; added note #3
6	1/1/2011	11.21	Overlaid Residential Cul-de-sac with raised Planter Island	Removed SW around bulb; added note #7
6	1/1/2011	20.00	NCDOT Standards for use in City of Charlotte and ETJ	Removed reference to 842.01, 842.02, 842.03 (Retaining Walls)
6	1/1/2011	20.03	Brick Double Catch Basin 15" thru 36" Pipe	Removed previous note #1 that exempted this detail from use on ETJ streets. OK now per NCDOT
6	1/1/2011	U-01 through U-07	USDG typical street sections	Added new typical sections for USDG streets
REVISION NO.	REVISION DATE	STANDARD NO.	NAME	DESCRIPTION OF REVISION
7	7/1/2011	10.26	Type III Driveway Entrance	Added note re: option for depth of concrete gutter across entrance
7	7/1/2011	10.36A	Culvert Crossings on Residential and Commercial Streets	Replaced "Handrail" reference with "Safety Rail"
7	7/1/2011	10.36B	Culvert Crossings on Residential and Commercial Streets	Replaced "Handrail" reference with "Safety Rail"
7	7/1/2011	20.05A	Slab Type Catch Basin 15" Thru 48" Pipe	Added option for using Drop Inlet Frame and Grate NCDOT standard 840.16
7	7/1/2011	20.21	Rip Rap Aprons at Outfalls Other than SWM	Added Thickness 10' file, to match Site Checklist
7	7/1/2011	50.04A	Safety Rail	Changed name from "typical Handrail" to "Safety Rail" to avoid confusion relating to ADA requirements
7	7/1/2011	50.04B	Safety Rail Warrants	Changed name, revised and updated the warrants. Added detailed exhibits
REVISION NO.	REVISION DATE	STANDARD NO.	NAME	DESCRIPTION OF REVISION
8	1/1/2012	10.27A	Residential Driveway (Type I) For 2'-0" Valley Gutter	Moved Section A-A to middle of apron to better illustrate 6" thickness requirement
8	1/1/2012	11.13	Private Street Typical Sections	Added note 4, re: section not to be used to meet connectivity req'ts of Subdivision/Zoning ordinances

REVISION NO.	REVISION DATE	STANDARD NO.	NAME	DESCRIPTION OF REVISION
8	1/1/2012	20.00C	NCDOT Standards for use in City of Charlotte and ETJ	Added clarifying note regarding 340.34, Traffic Bearing Junction Box
8	1/1/2012	20.03	Brick Double Catch Basin 15" thru 36" Pipe	Added note 8: re: weep holes
8	1/1/2012	20.07A	Concrete W/ingwall With Splash Pad	Fixed Type: Removed "M" label over the "H" column
8	1/1/2012	30.01	Temporary Sediment Trap	Changed Drainage Area max to 1 AC, per DWG SW General Permit requirements
8	1/1/2012	30.17A	Seeding Schedule	Removed notes 1 and 2, regarding seeding timeframes, see Site Checklist for new notes.
8	1/1/2012	50.09C	Parallel Parking Standards	Added info to note 5: re: sloping parking toward flow line only permitted if street grade is 2% or more.
9	7/1/2012	10.24C	Section IV, Approved Plant Species	Updated to the Approved Tree Species List, per Urban Forestry and L.S. Mgmt. adjust page #'s.
9	7/1/2012	10.25A	Residential Drop Curb Type I (Driveway with Planting Strip (2'-6" Curb and Gutter)	Removed previously shown sidewalk width, adjusted to provide 4' continuous passage
9	7/1/2012	10.25C	Residential Drop Curb Type I (Driveway with Planting Strip (6'x18" Vert curb)	Added minimum vertical dimension of 4' on flare
9	7/1/2012	10.25F	Commercial Type IV Driveway Standard	Added minimum vertical dimension of 4' on flare, drafting changes for clarity
9	7/1/2012	10.26	Drop Curb Driveway Monolithic Concrete Curb and Sidewalk	Added note 6" thickness through DW, removed "RW" for clarity
9	7/1/2012	10.32A	Accessible Ramp Standard without Planting Strip (2'-6" Curb and Gutter)	Adjusted dimensions for 4' Continuous Passage
9	7/1/2012	10.32B	Accessible Ramp Sections without planting strip (2'6" Curb & Gutter)	Adjusted dimensions for 4' Continuous Passage, added detectable warning mat in cross section
9	7/1/2012	10.34A	Accessible Ramp Standard Monolithic Curb and Sidewalk	Adjusted dimensions for 4' Continuous Passage
9	7/1/2012	10.34B	Accessible Ramp Sections Monolithic Curb and Sidewalk	Adjusted dimensions for 4' Continuous Passage, added detectable warning mat in cross section
9	7/1/2012	20.25	Trench Detail For Storm Drain	Fixed Type
9	7/1/2012	20.29	Overlapping Storm Drainage / Sanitary Sewer Easements	Revised diagram and adjusted note so ensure required trench width can be provided
9	7/1/2012	30.00	Special Erosion Control Requirements & Notes	Added reference to 6.11 Permanent Seeding, and added NCDOT Roadway Std. Dwgs as reference, along with NCDOT 1005.1 Special Sediment Fence
9	7/1/2012	37.17	Temporary Seeding Schedule	Revised detail to match NCDENR ESCPDM requirements and L.S. Mgmt requirements
9	7/1/2012	40.00A, B, C, D	Irrigation details	REMOVED details - similar details will be housed in separate Landscape Management standards doc
9	7/1/2012	40.04	Typical Valve and Valve Box Installation	New detail - replaces previous 40.04D
9	7/1/2012	40.05A	Shrub Planting Bed	Changed from 40.05 to 40.05A, "Acceptable Plant Media" note
9	7/1/2012	40.05B	Individual Small Shrub / Tree Planting	New Detail
9	7/1/2012	40.05A	Median Greater than 120 Inches, Excavation, Drainage and Backfill	Added 3' revised to update pipe options, allowing HDPE as well as PVC
9	7/1/2012	40.08B	75 to 120 Inch Median, Excavation, Drainage and Backfill	Note 3 revised to update pipe options, allowing HDPE as well as PVC
9	7/1/2012	40.08C	46 to 72 inch Median, Excavation, Drainage, and Backfill	Note 3 revised to update pipe options, allowing HDPE as well as PVC
9	7/1/2012	40.09	Root Crown Details	Changed title, changed wording to "Root Flare" instead of "Root Crown"
9	7/1/2012	40.11	Bridging Tree Roots	Added "Rebar Chairs" removed rebar embed detail, added diagonal groove joint
9	7/1/2012	50.05A	Street Name Sign	Complete revision to match City's current installation practice
9	7/1/2012	50.05B	Street Name Sign	Complete revision to match City's current installation practice
9	7/1/2012	50.06	Street Name Sign Installation Locations	Detail of post installation moved to 50.05A
9	7/1/2012	50.10A	Accessible Parking and Signage Standards	Updated to match current MUTCD/CSDM numbering, Changed table to ref ADA standards, added note 4, Changed sign for hatched spaces to "No Parking Any Time" MUTCD 821
9	7/1/2012	50.10B	Supplemental Van Accessible Sign (RP-8P)	Changed title, adjusted notations to match current MUTCD Manual
9	7/1/2012	50.10C	Supplemental Accessible Sign	Changed title, revised notations to match MUTCD
9	7/1/2012	50.14	Plano-style Crosswalk	New detail provided by CDOT
10	1/1/2013	11.09	Arterial Street Typical Section	Updated intermediate course thickness from 2.25 to 2.5" to match current SuperPave spec requirements
10	1/1/2013	11.19A	Residential Alley Detail One-Way Operation	Clarified dimensions D3 and D4
10	1/1/2013	11.19B	Residential Alley Detail Double-loaded with Two-Way Operation	Clarified dimensions D3 and D4
10	1/1/2013	11.19C	Residential Alley Detail Single-loaded with Two-Way Operation	Clarified dimensions D3 and D4
10	1/1/2013	20.00C	NCDOT Standards approved for use in City of Charlotte and ETJ	Changed 840.32 title to match current NCDOT manual title for same detail
10	1/1/2013	21.24	Surface Sand Filler	New detail, same as Mecklenburg County's detail of same number
10	1/1/2013	21.25	Surface Sand Filler Section	New detail, same as Mecklenburg County's detail of same number
10	1/1/2013	50.06	Street Name Sign Installation Locations	Moved street name signs and stop signs into planting strip for diagram with sidewalk shoun.
11	7/1/2013	Specs	Text page 9, note 2, "Sidewalks and Driveways"	Updated note 2 to reference correct detail numbers that have curb and gutter along driveway apron
11	7/1/2013	10.33B	Accessible Ramp Sections 2'-0" Valley Gutter	Added 6" sidewalk thickness dimension
11	7/1/2013	10.34B	Accessible Ramp Sections Monolithic Curb and Sidewalk	Added 6" sidewalk thickness dimension
11	7/1/2013	10.36A	Culvert Crossings on Residential and Commercial Streets	Fixed curb transition to reflect 10.19, added note #2 re: 8" SW at back of curb if wide PS & SW street
11	7/1/2013	U-07	Local Collector Street Typical Section	Fixed RW width dimension to be 36' ea. side - also added 26' dim from CL to SW if Valley Gutter
11	7/1/2013	11.09	Arterial Street Typical Section	Updated all course thicknesses to be consistent with current NCDOT requirements for Arterial Streets
11	7/1/2013	20.00A	NCDOT Standards Approved For Use in the City of Charlotte and Charlotte ETJ	300.01 was previously included on this table, but this revision removed reference to "Method A"
11	7/1/2013	20.25	Trench Detail For Storm Drain	Removed - reference to NCDOT 300.01 now included in 20.00A
11	7/1/2013	21.24	Surface Sand Filler	Detail re-drawn with different configuration so sand filler does not take up entire bottom of detention area & swapped inset detail for rip-rap berm into plan view, and put standpipe as "reset" detail
12	7/15/2014	10.25F	Type IV Driveway	Revised title of detail to "Type IV Driveway" from "Commercial Type IV Driveway, added info re: residential dw application, added note re: end treatment, added driveway standard width table
12	7/15/2014	10.31B	Accessible Ramp Section with Planting Strip 2'-6" Curb and Gutter	Drafting update for clarity, added detectable warning mat in section view
12	7/15/2014	10.32B	Accessible Ramp Sections without Planting Strip 2'-6" Curb and Gutter	Corrected dimension
12	7/15/2014	10.33B	Accessible Ramp Sections 2'-0" Valley Gutter	Added detectable warning mat in section view
12	7/15/2014	10.34B	Accessible Ramp Sections Monolithic Curb and Sidewalk	Corrected dimension
12	7/15/2014	10.35B	Truncated Domes Plan and Cross-section	Corrected dimensions, added reference to NCDOT 848.06
12	7/15/2014	10.40A	Directional Accessible Ramp With Small/Medium Curb Radii	Due to NCDOT concerns, added note re: not for use in ETJ, removed ETJ from title block
12	7/15/2014	10.40B	Directional Accessible Ramp With Large Curb Radius	Due to NCDOT concerns, added note re: not for use in ETJ, removed ETJ from title block
12	7/15/2014	11.01	Local Residential Street Typical Section	Added note re: ETJ Streets 1" may be placed when approved by NCDOT
12	7/15/2014	11.02	Local Residential Typical Ditch Type Street Section	Added note re: ETJ Streets 1" may be placed when approved by NCDOT
12	7/15/2014	11.03	Divided Residential Street Typical Section	Added note re: ETJ Streets 1" may be placed when approved by NCDOT
12	7/15/2014	11.04	Local Limited Residential Street Typical Section	Removed note re: sidewalk only on one side of street, Added ETJ 1" note
12	7/15/2014	11.05	Local Limited Residential Typical Ditch Type Street Section	Removed note re: sidewalk only on one side of street, Added ETJ 1" note
12	7/15/2014	11.06	Residential Collector Street Typical Section	Added note re: ETJ Streets 1" may be placed when approved by NCDOT
12	7/15/2014	11.07	Residential Collector Street Ditch Type Typical Section	Added note re: ETJ Streets 1" may be placed when approved by NCDOT
12	7/15/2014	11.08	Limited Residential Collector Street Type Typical Section	Added note re: ETJ Streets 1" may be placed when approved by NCDOT
12	7/15/2014	11.10	City of Charlotte 45' Local Traditional Neighborhood Development Street	Added note re: ETJ Streets 1" may be placed when approved by NCDOT
12	7/15/2014	11.16	City of Charlotte and ETJ Residential Cl-de-de Detail	Removed reference to ETJ, added note referencing NCDOT Subdivision Roads Minimum Construction Standards Manual, added cross section A-A showing grades at back of curb.
12	7/15/2014	11.18A	Residential Hammerhead Detail	Manual
12	7/15/2014	11.21	Overlaid Residential Cl-de-de-sacs with Raised Planter Island	Manual
12	7/15/2014	20.29	Sediment Detail	Added new detail views and notes regarding connections at storm structures
12	7/15/2014	30.02A	Skimmer Sediment Basin	Skimmer length requirement added, added notes, adjust pond bottom to include 1" sediment storage
12	7/15/2014	30.02B	Skimmer	Skimmer length requirement added
12	7/15/2014	30.03A	Sediment Basin	Skimmer length requirement added, added notes, adjust pond bottom to include 1" sediment storage; changed 3rd baffle to be a typical baffle instead of hardware cloth as previously shown
12	7/15/2014	30.11A	Stabilized Construction Entrance - Single Family Lot	Revised note #1 to read "sand" instead of "oil" added note re: sweeping aggregate each night
12	7/15/2014	30.11C	Slope Stability	New Detail
12	7/15/2014	40.03	Large and Small Maturing Tree Pit With Grate in Sidewalk (PLAN)	Added "Alternative 2" for 3' wide bench set on contour
12	7/15/2014	40.03C	Lattice and Small Maturing Tree Pit With Grate in Sidewalk (SECTION)	Adjusted dimension locations, show label curb & gutter
12	7/15/2014	40.11	Reinforced Concrete Sidewalk (Bridging Tree Roots)	Adjusted 1'-0" dimension and 5" dimension, show consistent soil hatch type
12	7/15/2014	50.10A	Accessible Parking and Signage Standards	Revised title of detail to "Reinforced Concrete Sidewalk (Bridging Tree Roots)", added note
12	7/15/2014	U-01	Local Residential Narrow Street Typical Section	Updated Accessible VAN Parking requirements to match Section 1106 of NC State Building Code, added code reference
12	7/15/2014	U-02	Local Residential Medium Street Typical Section	Added note re: ETJ Streets 1" may be placed when approved by NCDOT
12	7/15/2014	U-03A	Local Residential Wide Street Typical Section	Added note re: ETJ Streets 1" may be placed when approved by NCDOT
12	7/15/2014	U-03B	Local Residential Wide Street at Midblock with Curb Extension Typical Section	Added note re: ETJ Streets 1" may be placed when approved by NCDOT
12	7/15/2014	U-03C	Local Residential Wide Street at Intersection with Curb Extension Typical Section	Added note re: ETJ Streets 1" may be placed when approved by NCDOT
12	7/15/2014	U-07	Local Collector Street Typical Section	Added note re: ETJ Streets 1" may be placed when approved by NCDOT
13	7/31/2015	TEXT PG 9	Section I, F. (Sidewalks and Driveways)	add note referring to WATCH manual and MUTCD, latest edition - for construction zone pedestrian routes and signage and controls for actuators, revise I. F. 1. to read 1.5% (2.00% max) instead of 1/4" per foot, added table showing Example Construction Dimensions for sidewalk, included information regarding ramps at 7.5% (8.33% Max) slope, revised I.F.3. to read 5' min. wide sidewalk instead of 4' min.
13	7/31/2015	TEXT PG 10	Section II, A. (Storm Drainage)	Added note - no changes in storm pipe alignment except at structures, max length between access points is 300 LF
13	7/31/2015	TEXT PG 24	References	Added references to MUTCD and PROWAG
13	7/31/2015	10.22	Concrete Sidewalks	Revised notation to read 1.5% (2.00% max) instead of 1/4" per foot, revised min. width of sidewalk on thoroughfares to be 6' instead of 5' per USDC, added note 7. 8 per ADA consultant report, added table showing Example Construction Dimensions
13	7/31/2015	10.23	Monolithic Concrete Curb and Sidewalk	Revised notation to read 1.5% (2.00% max) instead of 1/4" per foot
13	7/31/2015	10.24A	Commercial Type II and Residential Drop Curb Type I Driveway with Sidewalk Abutting Curb (2'-6" Curb and Gutter)	Added note re: Fire access max 10%, revised notation to read 1.5% (2.00% max) instead of 1/4" per foot, revised 1:12 slope to read 7.5% (8.33% max), removed dimension on wings and label "varies", label sidewalk 5' min. width.
13	7/31/2015	10.24B	Commercial Type II and Residential Drop Curb Type I Driveway with Sidewalk Abutting Curb (6'x18" Vertical Curb)	Added note re: Fire access max 10%, revised notation to read 1.5% (2.00% max) instead of 1/4" per foot, revised 1:12 slope to read 7.5% (8.33% max), removed dimension on wings and label "varies", label sidewalk 5' min. width.
13	7/31/2015	10.24C	Commercial and Residential Drop Curb Driveway with Sidewalk Abutting Curb	Revised notation to read 1.5% (2.00% max) instead of 1/4" per foot, 1:12 Revised to read 7.5%, removed dimension on wings and labeled "varies", added note 4: re: joint material
13	7/31/2015	10.25A	Residential Drop Curb Type I (Driveway with Planting Strip (2'-6" Curb and Gutter)	Revised notation to read 1.5% (2.00% max) instead of 1/4" per foot, labeled sidewalk min. 5' width, added note re: Fire access max 10%, added note 7: re: joint material
13	7/31/2015	10.25B	Commercial Drop Curb Type II Driveway with Planting Strip (2'-6" Curb and Gutter)	Added note re: Fire access max 10%, revised notation to read 1.5% (2.00% max) instead of 1/4" per foot, revised 1:12 slope to read 7.5% (8.33% max), removed dimension on wings and label "varies", label sidewalk 5' min. width, added note re: joint material
13	7/31/2015	10.25C	Residential Drop Curb Type I (Driveway with Planting Strip (6'x18" Vertical Curb)	Added note re: Fire access max 10%, revised notation to read 1.5% (2.00% max) instead of 1/4" per foot, revised 1:12 slope to read 7.5% (8.33% max), removed dimension on wings and label "varies", label sidewalk 5' min. width, added note 7: re: joint material
13	7/31/2015	10.25D	Commercial Drop Curb Type II Driveway with Planting Strip (6'x18" Vertical Curb)	Added note re: Fire access max 10%, revised notation to read 1.5% (2.00% max) instead of 1/4" per foot, revised 1:12 slope to read 7.5% (8.33% max), removed dimension on wings and label "varies", label sidewalk 5' min. width, added note 7: re: joint material
13	7/31/2015	10.29E	Modified Type II Driveway Detail with Planting Strip	Added note re: Fire access max 10%, revised notation to read 1.5% (2.00% max) instead of 1/4" per foot, revised 1:12 slope to read 7.5% (8.33% max), removed dimension on wings and label "varies", label sidewalk 5' min. width, added note 7: re: joint material
13	7/31/2015	10.29F	Type IV Driveway	Show ex. sidewalk as dashed, label separation from curb taper to the sidewalk as "varies", 1' min., label curb depth taper as 2:1 over one foot, fix size of sidewalk panels shown, and fix plan view to match cross-section better with separation between the curb and the edge of sidewalk
13	7/31/2015	10.26	Drop Curb Driveway Monolithic Concrete Curb and Sidewalk	Change 1/4" per foot to 1.5% (2.00% max), change dimension from EP to back of sidewalk to be 6' Total Minimum, to be consistent with 10.23 Monolithic Curb and Sidewalk, added note re: Fire Access Road 10% max grade, removed dimension on flares to read "varies"
13	7/31/2015	10.27A	Residential Driveway (Type II) Valley Gutter	Added note re: Fire access max 10%, revised notation to read 1.5% (2.00% max) instead of 1/4" per foot, Change label for the joint at back of valley gutter to be an expansion joint, label sidewalk 5' min. width, revised 1/4" per foot to read 1.5% (2.00% max)
13	7/31/2015	10.27B	Commercial Type II Driveway for 2'-0" Valley Gutter	Added note re: Fire access max 10%, revised notation to read 1.5% (2.00% max) instead of 1/4" per foot, Change label for the joint at back of valley gutter to be an expansion joint, label sidewalk 5' min. width, revised 1/4" per foot to read 1.5% (2.00% max)
13	7/31/2015	10.28	Type III Driveway Entrance	Added callouts for expansion joints on both sides of driveway
13	7/31/2015	10.31A	Accessible Ramp Standard with Planting Strip 2'-6" Curb and Gutter (plan view)	Adjusted construction joints on ACC ramps to run straight back, remove dimensions on wings, change slopes to be consistent with PROWAG/ADA consultant report, added notes 1 and 2
13	7/31/2015	10.31B	Accessible Ramp Section with Planting Strip 2'-6" Curb and Gutter (section view)	Revised sidewalk slope of 1/4" per foot to read 1.5% (2.00% max) and ramp run to be 7.5% (8.33% max), added 2' distance between truncated dome mat and back of curb.

REVISION NO.	REVISION DATE	STANDARD NO.	NAME	DESCRIPTION OF REVISION
13	7/31/2015	10.32A	Accessible Ramp Standard without Planting Strip 2'-6" Curb and Gutter (plan view)	Adjust construction joints on ACC ramps to run straight back, remove dimensions on wings, change slopes to be compliant with PROWAGADA consultant report, added notes 1 and 2.
13	7/31/2015	10.32B	Accessible Ramp Sections without Planting Strip 2'-6" Curb and Gutter (section view)	Revised sidewalk slope of 1/4" per foot to read 1.5% (2.00% max) and ramp run to be 7.5% (8.33% max); added 2' distance between truncated dome mat and back of curb.
13	7/31/2015	10.33A	Accessible Ramp Standard 2'-0" Valley Gutter (plan view)	Adjust construction joints on ACC ramps to run straight back, remove dimensions on wings, change slopes to be compliant with PROWAGADA consultant report, added notes 1 and 2.
13	7/31/2015	10.33B	Accessible Ramp Sections 2'-0" Valley Gutter (section view)	Revised sidewalk slope of 1/4" per foot to read 1.5% (2.00% max) and ramp run to be 7.5% (8.33% max); added 2' distance between truncated dome mat and back of curb.
13	7/31/2015	10.34A	Accessible Ramp Standard Monolithic Curb and Sidewalk	Adjust construction joints on ACC ramps to run straight back, remove dimensions on wings, change slopes to be compliant with PROWAGADA consultant report, added notes 1 and 2.
13	7/31/2015	10.34B	Accessible Ramp Sections Monolithic Curb and Sidewalk	Revised sidewalk slope of 1/4" per foot to read 1.5% (2.00% max) and ramp run to be 7.5% (8.33% max); added 2' distance between truncated dome mat and back of curb.
13	7/31/2015	10.35A	Standard Placement of Accessible Ramp and General Notes	Show 7.5% ramp slope and 1.5% sidewalk cross slope; show note re: turning space; removed intersection diagrams since USGD includes better diagrams.
13	7/31/2015	10.35B	Truncated Domes Plan and Cross-Section	Added width of ramp to be covered with dome mat, width of truncated dome mat coverage must match width of sidewalk, revise notes 2, 3, 5.
13	7/31/2015	10.40A	Directional Ramp (Small Radius)	Updated 12:1 slope to read 7.5% (8.33% max) slope, and cross slope to 1.5% (2.00% max); added note clarifying 2' width of dome mat in di. of travel; changed "cut" to "gutter" in detail.
13	7/31/2015	10.40B	Directional Ramp (Large Radius)	Include note re: distance between edge of truncated dome mat and the depressed curb; add note for 1.5% (2.00% max) cross-slope, added note clarifying width of dome mat in di. of travel; changed 12:1 to 7.5% (8.33% max) slope; changed "cut" to "gutter" in detail.
13	7/31/2015	11.01	Local Residential Street Typical Section	REMOVED DETAIL - Street section superseded by USGD residential street section
13	7/31/2015	11.02	Local Residential Typical Ditch Type Street Section	Revised notation to read 1.5% (2.00% max) instead of 1/4" per foot, revised min width of sidewalk to be 5' instead of 4'
13	7/31/2015	11.03	Divided Residential Street Typical Section	REMOVED DETAIL - Divided street section detail not needed, will be site specific
13	7/31/2015	11.04	Local Limited Residential Street Typical Section	REMOVED DETAIL - Street section superseded by USGD residential street section
13	7/31/2015	11.05	Local Limited Residential Typical Ditch Type Street Section	REMOVED DETAIL - Limited street section no longer used
13	7/31/2015	11.06	Residential Collector Street Typical Section	REMOVED DETAIL - Street section superseded by USGD residential wide street section
13	7/31/2015	11.07	Residential Collector Street Ditch Type Typical Section	Revised notation to read 1.5% (2.00% max) instead of 1/4" per foot, revised min width of sidewalk to be 5' instead of 4'
13	7/31/2015	11.08	Limited Residential Collector Street Type Typical Section	REMOVED DETAIL - Limited street section no longer used
13	7/31/2015	11.09	Arterial Street Typical Sections	Revised SW X-slope to read 1.5% (2.00% max) instead of 1/4" per foot, revised to 8' min Plant strip and 8' min sidewalk width
13	7/31/2015	11.10	City of Charlotte 45 Local Traditional Neighborhood Development Street	REMOVED DETAIL - Street section no longer used
13	7/31/2015	11.11	Commercial Street Typical Section	REMOVED DETAIL - Street section superseded by USGD commercial street
13	7/31/2015	11.12	Commercial Street Divided Typical Section	REMOVED DETAIL - Divided street section detail not needed, will be site specific
13	7/31/2015	11.16	City of Charlotte Residential Cut-de-sac Detail	Aligned ramps perpendicular across neck of cut-de-sac
13	7/31/2015	11.18A	Residential Hammerhead Detail	Aligned ramps perpendicular across neck of hammerhead
13	7/31/2015	11.18B	Temporary Turnaround	Included cross slope to be 1.5%; removed other dimensions particular to a certain street type
13	7/31/2015	11.21	Oversized Residential Cut-de-Sac with Raised Planter Island	Aligned ramps perpendicular across neck of cut-de-sac
13	7/31/2015	20.34	Offset Catch Basin	add reference to 840.01 from NCDOT manual to detail max pipe size
13	7/31/2015	30.02A	Skimmer Sediment Basin	Remove 1' dimension from the emergency spillway, adjust sediment cleaned depth to be labeled H2, and ensure H is shown to the elevation of the spillway over the berm.
13	7/31/2015	30.03A	Sediment Basin	Remove hatching for 3rd baffle for clarity, adjusted sed cleaned depth and H dimension to proper location; removed #5 stone layer from rock baffle
13	7/31/2015	30.15	Catch Basin Inlet Protection	adjusted note re: filter bags are now allowed existing City or NCDOT roads, along with deflector note.
13	7/31/2015	40.03	Large and Small Maturing Tree Pit with Grate in Sidewalk (Plan)	add notes regarding keeping tree grates out of Pedestrian Access Route
13	7/31/2015	50.06	Street Name Sign Installation Locations	Show stop sign requirement and reference MUTCD changed "Street Name Sign Installation" to "Street Sign" since it includes street name as well as stop sign locations.
13	7/31/2015	50.09D	Accessible On-street Parallel Parking	"NEW DETAIL" - includes notes regarding tree planting locations, shows required item/design specs according to PROWAGADA
13	7/31/2015	50.10A	Accessible Parking and Signage Standards	Added notes 3 and 4; added accessible symbol on each parking space
13	7/31/2015	50.12	Emergency Vehicle Median Crossover Standards	Include note referencing standard 20.28, "Subdrain Detail" as applicable
13	7/31/2015	50.20	Inverted "U" Rack for Bicycle Parking	Added note #4 re: cane detectable and outside of PAR
13	7/31/2015	50.21	Wave Rack for Bicycle Parking	Added note #4 re: cane detectable and outside of PAR
13	7/31/2015	U-01	Local Residential Narrow Street Typical Section	Revised notation to read 1.5% (2.00% max) instead of 1/4" per foot, added note re: setback measurement
13	7/31/2015	U-02	Local Residential Medium Street Typical Section	Revised notation to read 1.5% (2.00% max) instead of 1/4" per foot, added note re: setback measurement
13	7/31/2015	U-03A	Local Residential Wide Street Typical Section	Revised notation to read 1.5% (2.00% max) instead of 1/4" per foot, added note re: setback measurement
13	7/31/2015	U-03B	Local Residential Wide Street at Midblock with Curb Extension Typical Section	Revised notation to read 1.5% (2.00% max) instead of 1/4" per foot, added note re: setback measurement
13	7/31/2015	U-03C	Local Residential Wide Street at Intersection with Curb Extension Typical Section	Revised notation to read 1.5% (2.00% max) instead of 1/4" per foot, added note re: setback measurement
13	7/31/2015	U-04	Local Office/Commercial Narrow Street Typical Section	Revised notation to read 1.5% (2.00% max) instead of 1/4" per foot, added note re: setback measurement
13	7/31/2015	U-05	Local Office/Commercial Wide Street Plan View	Adjusted width of detectable warning surface mats to match the width of ramps
13	7/31/2015	U-05A	Local Office/Commercial Wide Street Typical Section	Revised notation to read 1.5% (2.00% max) instead of 1/4" per foot, added note re: setback measurement
13	7/31/2015	U-05B	Local Office/Commercial Wide Street at Midblock with Curb Extension Typical	Revised notation to read 1.5% (2.00% max) instead of 1/4" per foot, added note re: setback measurement
13	7/31/2015	U-06	Local Office/Commercial Wide Street at Intersection with Curb Extension Typical	Revised notation to read 1.5% (2.00% max) instead of 1/4" per foot, added note re: setback measurement
13	7/31/2015	U-06	Local Industrial Street Typical Section	Revised notation to read 1.5% (2.00% max) instead of 1/4" per foot, added note re: setback measurement
13	7/31/2015	U-07	Local Collector Street	Revised notation to read 1.5% (2.00% max) instead of 1/4" per foot, added note re: setback measurement
14	7/29/2016	10.25E	Type III Driveway Detail With Wide Planting Strip and Standard Curb	Added Note #9 re: driveway rise 6" from gutter flow line
14	7/29/2016	10.28	Type III Driveway Entrance	Added Note #7 re: 2% cross-slope on crosswalk; notes and drafting updated for clarity of detail near ramps
14	7/29/2016	10.31A	Curb Ramp Standard with Planting Strip 2'-6" Curb and Gutter (plan view)	Changed name to "Perpendicular Curb Ramp", adjusted ramp plan and section for 8' planting strip, adjusted flowline depth to avoid non-accessible slope break previously shown
14	7/29/2016	10.31B	Accessible Ramp Section with Planting Strip 2'-6" Curb and Gutter (section view)	Replaced previous detail with isometric views of perpendicular ramps
14	7/29/2016	10.32A	Accessible Ramp Standard without Planting Strip 2'-6" Curb and Gutter (plan view)	DETAIL REMOVED
14	7/29/2016	10.32B	Accessible Ramp Sections without Planting Strip 2'-6" Curb and Gutter (section view)	DETAIL REMOVED
14	7/29/2016	10.33	Accessible Ramp Standard 2'-0" Valley Gutter (plan view)	Changed name to "Perpendicular Curb Ramp", single detail 10.33 now supersedes previous 10.33A and B. added isometric view; adjusted flow line depth to avoid non-accessible slope break previously shown
14	7/29/2016	10.33B	Accessible Ramp Sections 2'-0" Valley Gutter (section view)	DETAIL REMOVED
14	7/29/2016	10.34A	Accessible Ramp Standard Monolithic Curb and Sidewalk	DETAIL REMOVED
14	7/29/2016	10.34B	Accessible Ramp Sections Monolithic Curb and Sidewalk	DETAIL REMOVED
14	7/29/2016	10.35A	Standard Placement of Accessible Ramp and General Notes	Clarified note re: turning space for both views; added in Slope "A" on landing space on both details; changed name to "Curb Ramp" instead of "Accessible Ramp"; Added notes 8, 9, 10; included detail showing 4x4 crosswalk clear zone; added min. curb height at corners 2'
14	7/29/2016	10.40A	Directional Accessible Ramp (Small Radius)	Changed name to "Directional Curb Ramp", added note re: 2% landing if intersecting ramp.
14	7/29/2016	10.40B	Directional Accessible Ramp (Large Radius)	Changed name to "Directional Curb Ramp", added note re: 2% landing if intersecting ramp.
14	7/29/2016	10.41A	Pedestrian Refuge With 1'-0" Curb and Gutter	New Detail
14	7/29/2016	10.41B	Pedestrian Refuge With Vertical Curb	New Detail
14	7/29/2016	10.41C	Pedestrian Refuge With Modified Monolithic Curb	New Detail
14	7/29/2016	Text Pg. 9, 10	Section F, "Sidewalks, Curb Ramps, and Driveways"	Changed section name to include "curb ramps," included PROWAG statement as F.1; adjusted various notes to meet PROWAG.
15	1/16/2017	Text, page 5	Standards of Street Design - Streets and Intersections	Added K value for STOP condition, included new criteria for intersection design for PROWAG
15	1/16/2017	10.22	Concrete Sidewalks	Adjusted note 1, 4-5 intervals
15	1/16/2017	10.35A	Standard Placement of Accessible Ramp and General Notes	Adjusted diagram for 4'x4' square at corner ramp
15	1/16/2017	10.35B	Truncated Domes Plan and Cross-Section	Revised notes 6 & 7
15	1/16/2017	10.38	Curb Repairs at Existing Bus Stops	Added note 5, adjusted asphalt lift thickness to be consistent with current arterial street section
15	1/16/2017	11.02	Local Residential Typical Ditch Type Street Section	Added type in note 2
15	1/16/2017	30.00	Special Erosion Control Requirements & Notes	Removed hardware cloth for 3rd baffle; now use standard baffle
15	1/16/2017	30.01	Temporary Sediment Trap	Added note 2
15	1/16/2017	30.02A	Skimmer Sediment Basin	Added up ramp round under skimmer
15	1/16/2017	30.03A	Sediment Basin	Adjusted to provide sediment storage zone prior to rock berm
15	1/16/2017	30.03B	General Notes - Sediment Basins	Adjusted note 16
15	1/16/2017	30.05	Temporary Silt Ditch	Adjusted dimensions across top of berm to 8' total, with 2' width at top of berm; depth of ditch = 18"
15	1/16/2017	30.06A	Temporary Silt Fence	Show 8" and 4" dimensions on fabric bury - add note to anchor skirt
15	1/16/2017	30.06B	High Hazard Temporary Silt Fence	Show 8" and 4" dimensions on fabric bury - add note to anchor skirt, adjust note 4, remove note 6
15	1/16/2017	30.06C	Silt Fence Outlet	New Detail
15	1/16/2017	30.10A	Temporary Rock Check Dam	Renumbered 30.10 to 30.10A
15	1/16/2017	30.10B	Temporary Rock Check Dam With Matting and Optional PAM	New Detail
15	1/16/2017	30.10C	Temporary Waste Check Dam With Matting and Optional PAM	New Detail
15	1/16/2017	30.11A	Stabilized Construction Entrance	Adjusted note 1, note 6, added note 7, show re: DW and SW in plan and section view
15	1/16/2017	30.11B	Construction Entrance Tire Wash	Adjusted stone depth to 2'-3"
15	1/16/2017	30.12	Gravel and Rip Rap Filter Berm Basin	Added notes for 36" pipe-diameter max
15	1/16/2017	30.14	Temporary Stream Crossing	Fixed drafting on pipe; added surface flow diversion notes; added Note #4
15	1/16/2017	30.18	Construction Within Creek Bank	Detail REMOVED - see new details 30.22A, B, C
15	1/16/2017	30.19	Baffle Installation	Adjusted % area separation for each baffle to 25%; added note re: coir fabric
15	1/16/2017	30.22A	Bypass Pumping	New Detail
15	1/16/2017	30.22B	Suspended Bypass Pipe	New Detail
15	1/16/2017	30.22C	Piped Diversion	New Detail
15	1/16/2017	40.06	6' Tree Planting Strip UMJD Only	Added note 4; removed ETJ from title block; removed "R Requires" from Subdrain note
15	1/16/2017	40.11	Reinforced Concrete Sidewalk (Bridging Tree Roots)	Clarified where slope is to be placed; Added "headcut" to R57 stone references; added notes 1 and 2
15	1/16/2017	40.20	Inverted "U" Rack for Bicycle Parking	Added clarifying dimensions for placement and clearance; updated all notes
15	1/16/2017	50.21	Post and Ring Bike Rack	New Detail, replaces previous "Wave Rack" bike rack detail
16	7/31/2017	10.28	Type III Driveway Entrance	Concrete optional for apron area thru crosswalk; adjusted ramp illustration 8' x 4' conc. gutter illustration.
16	7/31/2017	10.31A	Perpendicular Curb Ramp with 2'-6" Curb and Gutter	Added "Up to" in slope key; revised notes re: slopes of landings; added note re: 13.33% alg. Diff.
16	7/31/2017	10.31B	Perpendicular Curb Ramp with 2'-6" Curb and Gutter	Added "Up to" in slope key; revised notes re: slopes of landings
16	7/31/2017	10.33	Perpendicular Curb Ramp with 2'-0" Valley Gutter	Added "Up to" in slope key; revised notes re: slopes of landings; added note re: 13.33% alg. Diff.
16	7/31/2017	10.40A	Directional Curb Ramp with Small/Medium Curb Radii	Added "Up to" in slope key; revised notes re: slopes of landings; added diagram of max slopes
16	7/31/2017	10.40B	Directional Curb Ramp with Large Curb Radius	Added "Up to" in slope key; revised notes re: slopes of landings; added diagram of max slopes
16	7/31/2017	NCOT Standards Approved For Use in the City of Charlotte and Charlotte ETJ	Added notes re: 840.53 and 840.53 re: if used as catch basin, need 12" vertical rise	
16	7/31/2017	50.04	Safety Rail	Added note re: alternative designs needing CDOT review, private maintenance
16	7/31/2017	50.04B	Safety Rail Warrants	Added 1' dimension from railing post to start of dropoff
16	7/31/2017	50.09D	Accessible On-street Parallel Parking	Added last baffle to note 7; added diagram of accessibility symbol position and orientation; Add note 15
16	7/31/2017	U-01	Local Residential Narrow Street Typical Section	Added note re: planting strip slopes
16	7/31/2017	U-02	Local Residential Medium Street Typical Section	Added note re: planting strip slopes
16	7/31/2017	U-03A	Local Residential Wide Street Typical Section	Added note re: planting strip slopes
16	7/31/2017	U-03B	Local Residential Wide Street at Midblock with Curb Extension Typical Section	Added note re: planting strip slopes
16	7/31/2017	U-03C	Local Residential Wide Street at Intersection with Curb Extension Typical Section	Added note re: planting strip slopes
16	7/31/2017	U-04	Local Office/Commercial Narrow Street Typical Section	Added note re: planting strip slopes; Revised pave section for options showing correct lift thickness.
16	7/31/2017	U-05A	Local Office/Commercial Wide Street Plan View	Added note re: planting strip slopes; Revised pave section for options showing correct lift thickness.
16	7/31/2017	U-05B	Local Office/Commercial Wide Street Typical Section	Added note re: planting strip slopes; Revised pave section for options showing correct lift thickness.
16	7/31/2017	U-05C	Local Office/Commercial Wide Street at Intersection with Curb Extension Typical Section	Added note re: planting strip slopes; Revised pave section for options showing correct lift thickness.
16	7/31/2017	U-06	Local Industrial Street Typical Section	Added note re: planting strip slopes
16	7/31/2017	U-07	Local Collector Street Typical Section	Added note re: planting strip slopes
17	7/31/2018	Text Pg 5	Standards of Street Design - Streets and Intersections	Added footnote re: 2% x 2% intersections use ramp standards, otherwise site specific detailed design needed
17	7/31/2018	Text Pg 10-11	Storm Drainage - Standards for Design	Added Pipe Video notes, shifted text up one page
17	7/31/2018	Text Pg 12	Storm Drainage - Reinforced Concrete	Remove notes 3 and 4, add new note 3 re: preformed joint sealer
17	7/31/2018	10.23	Monolithic Concrete Curb and Sidewalk	Removed detail, no longer used

REVISION NO.	REVISION DATE	STANDARD NO.	NAME	DESCRIPTION OF REVISION
17	7/31/2018	10.25B	Commercial Drop Curb Type II Driveway with Planting Strip (2'-6" Curb and Gutter)	Added note 8 re: planting strip < 6' use 10.25E
17	7/31/2018	10.25D	Commercial Drop Curb Type II Driveway with Planting Strip (6'x18" Vertical Curb)	Added note 8 re: planting strip < 6' use 10.25E
17	7/31/2018	10.26	Drop Curb Driveway Monolithic Concrete Curb and Sidewalk	Removed detail, no longer used
17	7/31/2018	10.28	Type II Driveway Entrance	Added note to clarify both ramps can be 10.31A/B, 10.40A/B - the ramps are shown as 10.40A for illustration purposes.
17	7/31/2018	10.31A	Perpendicular Curb Ramp With 2'-6" Curb and Gutter	Removed dimension 5' min. at toe of ramp; show "Match Sidewalk Width" instead
17	7/31/2018	10.33	Perpendicular Curb Ramp with 2'-0" Valley Gutter	Removed dimension 5' min. at toe of ramp; show "Match Sidewalk Width" instead
17	7/31/2018	10.35A	Placement of Curb Ramps at Obstructed or Small Corner Radius	Changed name; show typical landing space dimensions; removed 5-ft dim. On sidewalk; added 1' curb reveal at corner
17	7/31/2018	10.40A	Directional Curb Ramp with Small/Medium Curb Radii	Adjusted construction joint locations; added note 2; added note 5 re: SW/Tran. Panel; clarified details/corrected slopes
17	7/31/2018	10.40B	Directional Curb Ramp with Large Curb Radius	Adjusted construction joint locations; added note 2; added note 5 re: SW/Tran. Panel; clarified details/corrected slopes
17	7/31/2018	10.40C	Directional Curb Ramp with Valley Gutter	New Detail
17	7/31/2018	10.41A	Pedestrian Refuge (With 1'-6" Curb & Gutter)	Added Reflective Paddles
17	7/31/2018	10.41B	Pedestrian Refuge (With Vertical Curb)	Added Reflective Paddles
17	7/31/2018	10.41C	Pedestrian Refuge (Modified Monolithic)	Added Reflective Paddles
17	7/31/2018	11.02	Local Residential Typical Ditch Type Street Section	Revised Pavement Mix specs for consistency with NCDOT pavement requirements. No change in lift thicknesses.
17	7/31/2018	11.07	Residential Collector Street Ditch Type Street Typical Section	Revised Pavement Mix specs for consistency with NCDOT pavement requirements. No change in lift thicknesses.
17	7/31/2018	11.09	Thoroughfare Street Typical Sections	Changed name from "Arterial" to "Thoroughfare" and revised pavement mix spec per NCDOT
17	7/31/2018	11.13	Private Street Typical Sections	Revised Pavement Mix specs per NCDOT; also added Guidelines for design note 2. to refer to list B.2
17	7/31/2018	11.14	Divided Private Street Typical Sections	Revised Pavement Mix specs per NCDOT; also added Guidelines for design note 2. to refer to list B.2.
17	7/31/2018	11.19A	Residential Alley Detail One-Way Operation	Revised Pavement Mix per NCDOT; added note 6 to accommodate fire apparatus access road as needed
17	7/31/2018	11.19B	Residential Alley Detail Double Loaded w/ Two-Way Operation	Revised Pavement Mix per NCDOT; added note 5 to accommodate fire apparatus access road as needed
17	7/31/2018	11.19C	Residential Alley Detail Single Loaded w/ Two-Way Operation	Revised Pavement Mix per NCDOT; added note 5 to accommodate fire apparatus access road as needed
17	7/31/2018	20.27	Rip-Rap Ditches	Removed detail; no longer used
17	7/31/2018	20.35	Grading at Yard/Drop Inlet	Added "YARD" to name; added various data columns to data block; added note describing Invert elevation
17	7/31/2018	50.15	Raised Crosswalk	New Detail
17	7/31/2018	U-01	Local Residential Narrow Street Typical Section	Revised Pavement Mix specs for consistency with NCDOT pavement requirements. No change in lift thicknesses.
17	7/31/2018	U-02	Local Residential Medium Street Typical Section	Revised Pavement Mix specs for consistency with NCDOT pavement requirements. No change in lift thicknesses.
17	7/31/2018	U-03A	Local Residential Wide Street Typical Section	Revised Pavement Mix specs for consistency with NCDOT pavement requirements. No change in lift thicknesses.
17	7/31/2018	U-03B	Local Residential Wide Street at Midblock with Curb Extension Typical Section	Revised Pavement Mix specs for consistency with NCDOT pavement requirements. No change in lift thicknesses.
17	7/31/2018	U-03C	Local Residential Wide Street at Intersection with Curb Extension Typical Section	Revised Pavement Mix specs for consistency with NCDOT pavement requirements. No change in lift thicknesses.
17	7/31/2018	U-04	Local Office/Commercial Narrow Street Typical Section	Revised Pavement Mix specs for consistency with NCDOT pavement requirements. No change in lift thicknesses.
17	7/31/2018	U-05A	Local Office/Commercial Wide Street Plan View	Revised Pavement Mix specs for consistency with NCDOT pavement requirements. No change in lift thicknesses.
17	7/31/2018	U-05B	Local Office/Commercial Wide Street Typical Section	Revised Pavement Mix specs for consistency with NCDOT pavement requirements. No change in lift thicknesses.
17	7/31/2018	U-05C	Local Office/Commercial Wide Street at Intersection with Curb Extension Typical Section	Revised Pavement Mix specs for consistency with NCDOT pavement requirements. No change in lift thicknesses.
17	7/31/2018	U-06	Local Industrial Street Typical Section	Revised Pavement Mix specs for consistency with NCDOT pavement requirements. No change in lift thicknesses.
17	7/31/2018	U-07	Local Collector Street Typical Section	Revised Pavement Mix specs for consistency with NCDOT pavement requirements. No change in lift thicknesses.
REVISION NO.	REVISION DATE	STANDARD NO.	NAME	DESCRIPTION OF REVISION
18	1/31/2019	10.23	Sidewalk Transition	NEW DETAIL
18	1/31/2019	10.25E	Modified type II driveway detail with planting strip	Add note to match sidewalk width, or 5' min. across DW apron
18	1/31/2019	10.42	Multi-Use Path	NEW DETAIL
18	1/31/2019	21.05	Wetland Plan	Add notes to match BMP manual typ. req'ts and address embankment specs. (clean up detail)
18	1/31/2019	21.06	Wetland Profile	Add notes to match BMP manual typ. req'ts and address embankment specs. (clean up detail)
18	1/31/2019	21.08	Wetland Details	Add notes to match BMP manual typ. req'ts and address embankment specs. (clean up detail); renamed detail
18	1/31/2019	21.09	Wetland Planting Plan	Add notes to match BMP manual typ. req'ts and address embankment specs. (clean up detail)
18	1/31/2019	21.10	Wetland Plan	Add notes to match BMP manual typ. req'ts and address embankment specs. (clean up detail)
18	1/31/2019	21.11	Wetland Section	Add notes to match BMP manual typ. req'ts and address embankment specs. (clean up detail)
18	1/31/2019	21.13	Wetland Details	Add notes to match BMP manual typ. req'ts and address embankment specs. (clean up detail)
18	1/31/2019	21.14	Wetland Planting Plan	Add notes to match BMP manual typ. req'ts and address embankment specs. (clean up detail)
18	1/31/2019	21.24	Surface Sand Filler	Add notes to match BMP manual typ. req'ts and address embankment specs. (clean up detail)
18	1/31/2019	30.2A	Skimmer Sediment Basin	Added Surface treatment notes; removed 2' depth of sand option, since that doesn't meet typical 85% TSS removal goal
18	1/31/2019	30.2B	Skimmer Sediment Basin	Add note to clarify use of Turbidity Curtain as option for baffles
18	1/31/2019	30.2C	Sediment Basin	Add note to clarify use of Turbidity Curtain as option for baffles
18	1/31/2019	30.6B	Super Silt Fence	NEW DETAIL
18	1/31/2019	30.23A	Turbidity Curtain	NEW DETAIL
18	1/31/2019	30.23B	Turbidity Curtain Notes	NEW DETAIL
18	1/31/2019	50.10A	Accessible Parking and Signage Standards	Revised note #1 to reference proper sign numbers (all signs, not just the 12"x18" signs)
18	1/31/2019	50.10B	Supplemental Van Accessible Sign (RP-8P)	Revised height of lowest sign for ADA clearance
18	1/31/2019	50.10C	Supplemental Accessible Sign	Revised height of lowest sign for ADA clearance
REVISION NO.	REVISION DATE	STANDARD NO.	NAME	DESCRIPTION OF REVISION
19	1/30/2020	10.25B	Commercial Drop Curb Type II Driveway with Planting Strip (2'-6" Curb & Gutter)	Adjusted dimension on tapered concrete sides to 5' min.; to match sidewalk scoring
19	1/30/2020	10.25D	Commercial Drop Curb Type II Driveway with Planting Strip (6' x 18" Vertical Curb)	Adjusted dimension on tapered concrete sides to 5' min.; to match sidewalk scoring
19	1/30/2020	10.28	Type II Driveway Entrance	Added notes and lines for flowline and for foot joints through apron and sidewalk
19	1/30/2020	20.34	Offset Catch Basin	rebar
19	1/30/2020	30.12	Gravel and Rip-Rap Filter Berm Basin	Removed data block; removed note "that drain 5 ac. or less"
19	1/30/2020	50.04B	Safety Rail Warrants	Adjusted to clarify dimensions on rail placement and dim. From edge of sidewalk; changed E&PM to include Planning and Engineering; removed previous note 4 re: "where a pedestrian can be expected in the vicinity"; removed detail of pedestrian clear zone
19	1/30/2020	U-01	Local Residential Narrow Street Typical Section	Removed "Includes ETJ/Added "Not for use in ETJ"; Adjusted tack coat note; removed surface course item 3 " when approved by NCDOT"
19	1/30/2020	U-02	Local Residential Medium Street Typical Section	Adjusted tack coat note; added notes to clarify 11' lanes required if used in ETJ
19	1/30/2020	U-03	Local Residential Wide Street Plan View	Removed "Includes ETJ/Added "Not for use in ETJ"; added notes to U-03B and U-03C since not for use in ETJ
19	1/30/2020	U-03A	Local Residential Wide Street Typical Section	ETJ
19	1/30/2020	U-03B	Local Residential Wide Street at Midblock with Curb Extension Typical Section	Removed "Includes ETJ/Added "Not for use in ETJ"; adjusted tack coat note; removed surface course note 3 " when approved by NCDOT"
19	1/30/2020	U-03C	Local Residential Wide Street at Intersection with Curb Extension Typical Section	Removed "Includes ETJ/Added "Not for use in ETJ"; adjusted tack coat note; removed surface course note 3 " when approved by NCDOT"
19	1/30/2020	U-04	Local Office/Commercial Narrow Street Typical Section	Removed "Includes ETJ/Added "Not for use in ETJ"; adjusted tack coat note
19	1/30/2020	U-05	Local Office/Commercial Wide Street Plan View	Removed "Includes ETJ/Added "Not for use in ETJ"; adjusted tack coat note
19	1/30/2020	U-05A	Local Office/Commercial Wide Street Typical Section	Removed "Includes ETJ/Added "Not for use in ETJ"; adjusted tack coat note
19	1/30/2020	U-05B	Local Office/Commercial Wide Street at Midblock with Curb Extension Typical Section	Removed "Includes ETJ/Added "Not for use in ETJ"; adjusted tack coat note
19	1/30/2020	U-05C	Local Office/Commercial Wide Street at Intersection with Curb Extension Typical Section	Removed "Includes ETJ/Added "Not for use in ETJ"; adjusted tack coat note
19	1/30/2020	U-05D	Local Office/Commercial Wide Street Typical Section (TOD ONLY)	NEW DETAIL; to be replaced per TOD guidelines adopted 4/16/2019
19	1/30/2020	U-06	Local Industrial Street Typical Section	Adjusted tack coat note; added notes to clarify pavement section for ETJ; revised min. RW width to use even-number of 52' in ETJ only
19	1/30/2020	U-07	Local Collector Street Typical Section	Adjusted tack coat note; revised min. RW width to use even-number of 52' in ETJ only
REVISION NO.	REVISION DATE	STANDARD NO.	NAME	DESCRIPTION OF REVISION
20	1/29/2021	10.17B	Curb and Gutter	Adjusted 2' dimension on mountable c&g - fix drafting error; also add note re: 10' median c&g for city streets only
20	1/29/2021	10.22	Concrete Sidewalks	Add note re: joint spacing on wide sidewalks = width of sidewalk
20	1/29/2021	10.25F	Type IV Driveway	Add driveway slopes and breakovers to match other commercial driveways; add fire access notes to match; adjusted 4' MIN. to flare; removed confining RW line from detail
20	1/29/2021	10.31A	Perpendicular Curb Ramp With 2'-6" Curb and Gutter	Minor cad drawing adjustment at "varies" dimension at end of flares
20	1/29/2021	10.31B	Perpendicular Curb Ramp with 2'-0" Valley Gutter	Changed term "Wings" to "Flares"; Added "ALTERNATIVE" labels for each illustration
20	1/29/2021	10.33	Perpendicular Curb Ramp with 2'-0" Valley Gutter	Minor drawing adjustment at "varies" dimension at end of flares
20	1/29/2021	10.40B	Directional Curb Ramp with Large Curb Radius	Minor drawing adjustments - clarify 6" radius on returned curb
20	1/29/2021	10.42	Multi-Use Path	Added notes, clarified pavement sections, adjusted outfall slope and add SUE; added INSET A; revised pavement schedule alternatives table for legibility.
20	1/29/2021	11.02	Local Residential Typical Ditch Type Street Section	Show SUE 2' off back of sidewalk.
20	1/29/2021	11.07	Residential Collector Street Ditch Type Street Typical Section	Show SUE 2' off back of sidewalk.
20	1/29/2021	20.00C	NCDOT Standards Approved For Use in the City of Charlotte and Charlotte ETJ	Add note re: openings in manhole covers
20	1/29/2021	20.03	Double Brick Catch Basin	Removed "Includes ETJ" and add note: not for use on NCDOT Roadways or in ETJ
20	1/29/2021	21.05	Wetland Plan	Add note prohibiting HDPE or CMP outlet pipes through embankment
20	1/29/2021	21.06	Wetland Profile	Add note prohibiting HDPE or CMP outlet pipes through embankment
20	1/29/2021	21.08	Wetland Details	Change weir dimensions to match BMP Manual
20	1/29/2021	21.10	Wetland Plan	Add note prohibiting HDPE or CMP outlet pipes through embankment
20	1/29/2021	21.11	Wetland Section	Add note prohibiting HDPE or CMP outlet pipes through embankment
20	1/29/2021	21.24	Surface Sand Filler Section View	Add note prohibiting HDPE or CMP outlet pipes through embankment
20	1/29/2021	30.04	Slope Drain	Add notes / table per NCDOT E&M
20	1/29/2021	30.05	Temporary Silt Ditch	Add dimensions data block and notes 3 & 4; added 2.1 max labels on all slopes
20	1/29/2021	30.06C	Silt Fence Outlet	Add note 4 and 5; edit drawing to clarify show height of fencing and stone
20	1/29/2021	30.10C	Temporary Wash Check Dam With Matting and Optional PAM	Add dimension for depth of ditch in section views
20	1/29/2021	30.18	Temporary Asphalt Diversion	NEW DETAIL
20	1/29/2021	U-05D	Commercial Wide Street Typical Section (TOD Only)	Revised half RW dimensions to add up properly to total RW
20	1/29/2021	TEXT	Specifications and Special Provisions Notes	Revised structure of Storm Drainage section; defined endwall types allowed; added requirement for pipe joint wrapping; updated pipe cover requirements; added requirement for joint structure or collar at connections of different materials or pipes from different manufacturers; added requirement for holes in manhole covers; consolidated backfill section for all pipe materials; added requirement for sealing lift holes; documented maximum slope for reinforced concrete pipe; added
REVISION NO.	REVISION DATE	STANDARD NO.	NAME	DESCRIPTION OF REVISION
21	7/1/2021	10.17C	Curb and Gutter	Add note: 7. For curb and gutter installations the ETJ, NCDOT requires that all joints must be filled with joint sealer per NCDOT Standard Specifications for Roads and Structures, Section 845.3 (0.1)
21	7/1/2021	10.27B	Commercial Type II Driveway for 2'-0" Valley Gutter	Add note "Planting strip width varies (4' min) to clarify minimum 4' dimension, similar to other driveway details.
21	7/1/2021	10.43	Bike Ramp	New Detail
21	7/1/2021	10.44	Tackle Guide Strip	New Detail
21	7/1/2021	10.45A	Truck Apron at Intersection	New Detail
21	7/1/2021	10.45B	Truck Apron at Roundabout	New Detail
21	7/1/2021	30.18	Rolled Asphalt Berm	note #5: "Catch basin inlet protection may be omitted if approved by Erosion Control Coordinator"
REVISION NO.	REVISION DATE	STANDARD NO.	NAME	DESCRIPTION OF REVISION
22	7/29/2022	10.39	Modular Retaining Walls Using Geogrid In the Right-of-Way	Changed "handrail" to "safety rail"; removed culvert from section and plan view; removed culvert endwall; added notes to prohibit use of detail on NCDOT streets; add note re: no geogrid in CLT WATER esmt or near utility; removed "And ETJ" from title block
22	7/29/2022	30.02A	Skimmer Sediment Basin	Removed note for 10' spacing; adjust baffle lines
22	7/29/2022	30.03A	Sediment Basin	Removed note for 10' spacing of baffles
22	7/29/2022	30.05	Temporary Silt Ditch	Add legend for values on column headers; added labels in section view
22	7/29/2022	30.10B	Temporary Rock Check Dam With Matting and PAM	Remove "OPTIONAL" from title
22	7/29/2022	30.19	Baffle Installation	Removed note for 10' spacing of baffles; added note 3 re: smaller basins
22	7/29/2022	30.20	Embankment Matting Detail	Add note regarding matting netting material req'ts & TRM's permitted
REVISION NO.	REVISION DATE	STANDARD NO.	NAME	DESCRIPTION OF REVISION
23	4/1/2023	TEXT	Pg. 4	Updated approval authority of Hilly Terrain criteria to CDOT Director. Updated reference to current version of NCDOT Subdivision Manual.
23	4/1/2023	TEXT	Pg. 5	Added line 2.d. Revised approval authority in Note C to Director of Transportation
23	4/1/2023	TEXT	Pg. 6	Updated min. radius table with new street classifications
23	4/1/2023	TEXT	Pg. 14	Revised "Thoroughfare" to "Arterial/Upown Street" Removed "City Engineer" from Paragraph 3
23	4/1/2023	TEXT	Pg. 16	Revised Para. 4 to be consistent with updated sight distance policy
23	4/1/2023	TEXT	Pg. 6	Replaced notes 3 and 4 with new item detailing 3rd party inspection of flexible pipe
23	4/1/2023	TEXT	Pg. 16	Revised Para. B.1 to reference UDD

REVISION NO.	REVISION DATE	STANDARD NO.	NAME	DESCRIPTION OF REVISION
23	4/1/2023	TEXT	Pg. 18	Revised references to "City Engineer" to "City"
23	4/1/2023	TEXT	Pg. 26	Added reference #14 "Charlotte Streets Manual"
23	4/1/2023	10.22	Concrete Sidewalks	Updated the text in notes to reflect new UDO standards.
23	4/1/2023	10.24A	Commercial Type I And Residential Type I Drop Curb Driveway with Sidewalk Abutting Curb (2'-6" Curb and Gutter)	Updated the text in notes to reflect new UDO standards. Changed dimensions to reflect new UDO standards. Updated Driveway Width table.
23	4/1/2023	10.24B	Commercial Type II And Residential Type I Drop Curb Driveway with Sidewalk Abutting Curb (6" X 18" Curb and Gutter)	Updated the text in notes to reflect new UDO standards. Changed dimensions to reflect new UDO standards. Updated Driveway Width table.
23	4/1/2023	10.24C	Commercial Type II And Residential Type I Drop Curb Driveway with Sidewalk Abutting Curb (6" X 18" Vertical Curb)	Updated the text in notes to reflect new UDO standards. Changed dimensions to reflect new UDO standards. Updated Driveway Width table.
23	4/1/2023	10.25A	Residential Drop Curb Type I (Driveway with Planting Strip (2'-6" Curb and Gutter)	Changed dimensions to reflect new UDO standards. Updated Driveway Width table.
23	4/1/2023	10.25B	Residential Drop Curb Type I (Driveway with Planting Strip (2'-6" Curb and Gutter)	Changed dimensions to reflect new UDO standards.
23	4/1/2023	10.25C	Residential Drop Curb Type I (Driveway with Planting Strip (6" X 18" Vertical Curb)	Changed dimensions to reflect new UDO standards. Updated Driveway Width table.
23	4/1/2023	10.25D	Commercial Drop Curb Type I Driveway with Planting Strip (6" X 18" Vertical Curb)	Changed dimensions to reflect new UDO standards.
23	4/1/2023	10.25E	Type II Modified Driveway Detail with Wide Planting Strip and Standard Curb	Changed dimensions to reflect new UDO standards. Add note 10: no transition on either side if used on valley gutter
23	4/1/2023	10.25F	Type IV Driveway	Changed dimensions to reflect new UDO standards. Updated Driveway Width table. Per NCDOT request, show PPES as base design, with notes allowing PES on city streets only.
23	4/1/2023	10.27A	Residential Driveway (Type I) for 2'-0" Valley Gutter	Changed dimensions to reflect new UDO standards.
23	4/1/2023	10.27B	Commercial Type II Driveway For 2'-0" Valley Gutter	Changed dimensions to reflect new UDO standards.
23	4/1/2023	10.28	Type III Driveway Entrance	Changed sidewalk width dimension to reflect new UDO standards.
23	4/1/2023	10.31A	Perpendicular Curb Ramp with 2'-0" Curb and Gutter	Changed sidewalk width dimension to reflect new UDO standards.
23	4/1/2023	10.33	Perpendicular Curb Ramp with 2'-0" Valley Gutter	Changed sidewalk width dimension to reflect new UDO standards.
23	4/1/2023	10.36A	Culvert Crossings on Residential and Commercial Streets	Updated legend and sidewalk width dimension to reflect new UDO standards.
23	4/1/2023	10.36B	Culvert Crossings on Residential and Commercial Streets	Revised "City Engineer" to "City"
23	4/1/2023	10.37	Typical Wider Street to Narrow Street Taper	Updated the text in notes to reflect new UDO standards. Changed dimensions to reflect new UDO standards. Revised detail title.
23	4/1/2023	10.38	Curb Repairs at Existing Bus Stops	Revised "City Engineer" to "City"
23	4/1/2023	10.41A	Pedestrian Refuge (With 1'-6" Curb & Gutter)	Removed references to colored concrete
23	4/1/2023	10.41B	Pedestrian Refuge (With Vertical Curb)	Removed references to colored concrete
23	4/1/2023	10.41C	Pedestrian Refuge (Modified Manwith)	Revised concrete type
23	4/1/2023	10.42	Shared Use Path (SUP)	Revised detail title. Added Note 6: Revised Sidewalk and Utility Easement callout. Edited notes to change MUP to SUP
23	4/1/2023	10.43	Bike Ramp	Revised MUP to SUP throughout
23	4/1/2023	10.45A	Truck Apron at Intersection	Removed references to colored concrete on city-maintained facilities
23	4/1/2023	10.45B	Truck Apron at Roundabout	Clarified truck apron cross slope requirements
23	4/1/2023	11.02	Local Residential Typical Ditch Type Street Section	Removed references to colored concrete
23	4/1/2023	11.07	Residential Collector Street Ditch Type Street Typical Section	Revised "City Engineer" to "City". Added SUP to Note 2; removed Comp. Street Classification from title
23	4/1/2023	11.07A	Residential Collector Street Ditch Type Street Typical Section (6' Sidewalk)	Replaced with 11.07A & B
23	4/1/2023	11.07B	Residential Collector Street Ditch Type Street Typical Section (8' Sidewalk)	Added sidewalk width specific to detail; adjusted total ROW to back of sidewalk; replaced "City Engineer" with "City" in note #3; removed Comp. Street Class from title block. Adjusted note 2 to describe SUE
23	4/1/2023	11.09	Arterial Street Typical Sections	Revised detail title. Added Note 4: Revised Street Classifications to Arterial. Updated dimension to reflect the new UDO. Revised "City Engineer" to "City"
23	4/1/2023	11.13	Private Street Typical Sections	Revised "City Engineer" to "City"
23	4/1/2023	11.14	Divided Private Street Typical Sections	Revised "City Engineer" to "City"
23	4/1/2023	11.16	City of Charlotte Residential Cut-de-sac Detail	Revised "City Engineer" to "City"
23	4/1/2023	11.17	Office/Commercial/Industrial Cut-de-sac Detail	Revised "City Engineer" to "City"
23	4/1/2023	40.01	Tree Planting	Replaced notes; replaced ANSI reference
23	4/1/2023	40.02	Tree Protection Detail	Added new notes 4 & 5
23	4/1/2023	40.03B	Large and Small Maturing Tree Pit with Grate in Sidewalk (Section)	Removed reference to 40.08B for tree support system
23	4/1/2023	40.06	6" Tree Planting Strip (UMD Only)	Removed notes 2 & 3; added new notes 2 & 3. Changed Title to "PLANTING STRIPS LESS THAN 6" IN WIDTH"
23	4/1/2023	40.08A	Median Greater than 120 inches Excavation, Drainage and Backfill	Replaced note 2
23	4/1/2023	40.08B	73 to 120 inch Median Excavation, Drainage and Backfill	Replaced Note 2
23	4/1/2023	40.08C	48 to 72 inch Median Excavation, Drainage and Backfill	Replaced Note 2
23	4/1/2023	40.09	Root Flare Digging	Changed "City Arborist" reference to "City"
23	4/1/2023	40.10	Tree Planting - Notes	DETAIL REMOVED; no longer needed; info is provided in CTM and L&S Construction Stds.
23	4/1/2023	40.11	Reinforced Concrete Sidewalk (Bridging Tree Roots)	Changed note 1 to read DBH instead of Caliper; replaced "in areas beyond root zone" with "around roots" in section A-A
23	4/1/2023	40.12	Temporary Tree Protection Detail	Replaced ref's for Engineer or City Arborist with "CITY"; revised note 4; changed title to "TEMPORARY TREE TRUNK PROTECTION DETAIL"
23	4/1/2023	40.13	Asphalt Curb Placement at Existing Trees	Removed note 5; changed ref's to City Arborist or Engineer to "CITY"
23	4/1/2023	40.14	Rock Chimney	Replaced CLESM reference with CTM and LANDSCAPE CONSTRUCTION STANDARDS; add ref to CLDSM 40.02 in note 3
23	4/1/2023	50.01A	Precast Concrete Pavers for Updown Streetscape	NEW DETAIL
23	4/1/2023	50.01B	Precast Concrete Pavers for Updown Streetscape	NEW DETAIL
23	4/1/2023	50.01C	Precast Concrete Pavers for Updown Streetscape	NEW DETAIL
23	4/1/2023	50.05A	Street Name Sign	Deleted Note 3 that mentioned CDOT Director and City Engineer approval of street signs
23	4/1/2023	50.09C	Parallel Parking Standards	Revised Note 6; Revised Parallel Parking Chart
23	4/1/2023	50.09D	Accessible On-Street Parallel Parking	Added Note 16
23	4/1/2023	50.10A	Accessible Parking and Signage Standards	Added Note 5
23	4/1/2023	50.15	Raised Crosswalk	Revised flare width to 10'; and chevron length to 6' instead of 6'
23	4/1/2023	U-01	Local Residential Narrow Street Typical Section	DETAIL REMOVED
23	4/1/2023	U-02	Local Residential Medium Street Typical Section	DETAIL REPLACED BY U-02A and U-02B
23	4/1/2023	U-02A	Local Residential Medium Street Typical Section (6' Sidewalk)	Added sidewalk width specific to detail; adjusted total ROW to back of sidewalk; replaced "City Engineer" with "CDOT" in planting strip exceptions note; removed explanation of right-of-way note; added note about amenity zone; added note about buffer width
23	4/1/2023	U-02B	Local Residential Medium Street Typical Section (8' Sidewalk)	Added sidewalk width specific to detail; adjusted total ROW to back of sidewalk; replaced "City Engineer" with "CDOT" in planting strip exceptions note; removed explanation of right-of-way note; added note about amenity zone; added note about buffer width
23	4/1/2023	U-03	Local Residential Wide Street Plan View	Updated X-section labels; removed note 3; removed sidewalk dimension and arrows
23	4/1/2023	U-03A	Local Residential Wide Street Typical Section	DETAIL REPLACED WITH U-03A1 and U-03A2
23	4/1/2023	U-03A1	Local Residential Wide Street Typical Section (6' Sidewalk)	Added sidewalk width specific to detail; adjusted total ROW to back of sidewalk; replaced "City Engineer" with "City" in base course callout; added "City" in Note 1; removed sidewalk min note; removed explanation of right-of-way note; removed zoning setback note; added note about amenity zone; added note about buffer width; replaced "City Engineer" with "CDOT" in planting strip exceptions note
23	4/1/2023	U-03A2	Local Residential Wide Street Typical Section (8' Sidewalk)	Added sidewalk width specific to detail; adjusted total ROW to back of sidewalk; replaced "City Engineer" with "City" in base course callout; added "City" in Note 1; removed sidewalk min note; removed explanation of right-of-way note; removed zoning setback note; added note about amenity zone; added note about buffer width; replaced "City Engineer" with "CDOT" in planting strip exceptions note
23	4/1/2023	U-03B	Local Residential Wide Street At Midblock With Curb Extension Typical Section	DETAIL REPLACED WITH U-03B1 and U-03B2
23	4/1/2023	U-03B1	Local Residential Wide Street At Midblock With Curb Extension Typical Section (6' Sidewalk)	Added sidewalk width specific to detail; adjusted total ROW to back of sidewalk; replaced "City Engineer" with "City" in base course callout; added "City" in Note 1; removed sidewalk min note; removed explanation of right-of-way note; removed zoning setback note; added note about amenity zone; added note about buffer width; replaced "City Engineer" with "CDOT" in planting strip exception note
23	4/1/2023	U-03B2	Local Residential Wide Street At Midblock With Curb Extension Typical Section (8' Sidewalk)	Added sidewalk width specific to detail; adjusted total ROW to back of sidewalk; replaced "City Engineer" with "City" in base course callout; added "City" in Note 1; removed sidewalk min note; removed explanation of right-of-way note; removed zoning setback note; added note about amenity zone; added note about buffer width; replaced "City Engineer" with "CDOT" in planting strip exception note
23	4/1/2023	U-03C	Local Residential Wide Street At Intersection With Curb Extension Typical Section	DETAIL REPLACED WITH U-03C1 and U-03C2
23	4/1/2023	U-03C1	Local Residential Wide Street At Intersection With Curb Extension Typical Section (6' Sidewalk)	Added sidewalk width specific to detail; adjusted total ROW to back of sidewalk; replaced "City Engineer" with "City" in base course callout; added "City" in Note 1; removed sidewalk min note; removed explanation of right-of-way note; removed zoning setback note; added note about amenity zone; added note about buffer width; replaced "City Engineer" with "CDOT" in planting strip exception note
23	4/1/2023	U-03C2	Local Residential Wide Street At Intersection With Curb Extension Typical Section (8' Sidewalk)	Added sidewalk width specific to detail; adjusted total ROW to back of sidewalk; replaced "City Engineer" with "City" in base course callout; added "City" in Note 1; removed sidewalk min note; removed explanation of right-of-way note; removed zoning setback note; added note about amenity zone; added note about buffer width; replaced "City Engineer" with "CDOT" in planting strip exception note
23	4/1/2023	U-04	Local Office/Commercial Narrow Street Typical Section	DETAIL REPLACED WITH U-04A and U-04B
23	4/1/2023	U-04A	Local Office/Commercial Narrow Street Typical Section (6' Sidewalk)	Added sidewalk width specific to detail; adjusted total ROW to back of sidewalk; replaced "City Engineer" with "City" in Note 2; removed explanation of right-of-way note; removed zoning setback note; added note about amenity zone; added note about buffer width; replaced "City Engineer" with "CDOT" in planting strip exception note
23	4/1/2023	U-04B	Local Office/Commercial Narrow Street Typical Section (8' Sidewalk)	Added sidewalk width specific to detail; adjusted total ROW to back of sidewalk; replaced "City Engineer" with "City" in Note 2; removed explanation of right-of-way note; removed zoning setback note; added note about amenity zone; added note about buffer width; replaced "City Engineer" with "CDOT" in planting strip exception note
23	4/1/2023	U-05A	Local Office/Commercial Wide Street Typical Section	Updated X-section labels; removed sidewalk dimension and S planting strip dimension
23	4/1/2023	U-05A1	Local Office/Commercial Wide Street Typical Section (6' Sidewalk)	Added sidewalk width specific to detail; adjusted total ROW to back of sidewalk; replaced "City Engineer" with "City" in Note 3; removed explanation of right-of-way note; removed zoning setback note; revised note about amenity zone; added note about buffer width; replaced "City Engineer" with "CDOT" in planting strip exception note
23	4/1/2023	U-05A2	Local Office/Commercial Wide Street Typical Section (8' Sidewalk)	Added sidewalk width specific to detail; adjusted total ROW to back of sidewalk; replaced "City Engineer" with "City" in Note 3; removed explanation of right-of-way note; removed zoning setback note; revised note about amenity zone; added note about buffer width; replaced "City Engineer" with "CDOT" in planting strip exception note
23	4/1/2023	U-05B	Local Office/Commercial Wide Street At Midblock With Curb Extension Typical Section	DETAIL REPLACED WITH U-05B1 and U-05B2
23	4/1/2023	U-05B1	Local Office/Commercial Wide Street At Midblock With Curb Extension Typical Section (6' Sidewalk)	Added sidewalk width specific to detail; adjusted total ROW to back of sidewalk; replaced "City Engineer" with "City" in Note 3; removed explanation of right-of-way note; removed zoning setback note; revised note about amenity zone; added note about buffer width; replaced "City Engineer" with "CDOT" in planting strip exception note
23	4/1/2023	U-05B2	Local Office/Commercial Wide Street At Midblock With Curb Extension Typical Section (8' Sidewalk)	Added sidewalk width specific to detail; adjusted total ROW to back of sidewalk; replaced "City Engineer" with "City" in Note 3; removed explanation of right-of-way note; removed zoning setback note; revised note about amenity zone; added note about buffer width; replaced "City Engineer" with "CDOT" in planting strip exception note
23	4/1/2023	U-05C	Local Office/Commercial Wide Street At Intersection With Curb Extension Typical Section	Replaced with U-05C1 and U-05C2
23	4/1/2023	U-05C1	Local Office/Commercial Wide Street At Intersection With Curb Extension Typical Section (6' Sidewalk)	Added sidewalk width specific to detail; adjusted total ROW to back of sidewalk; replaced "City Engineer" with "City" in Note 3; removed explanation of right-of-way note; removed zoning setback note; revised note about amenity zone; added note about buffer width; replaced "City Engineer" with "CDOT" in planting strip exception note
23	4/1/2023	U-05C2	Local Office/Commercial Wide Street At Intersection With Curb Extension Typical Section (8' Sidewalk)	Added sidewalk width specific to detail; adjusted total ROW to back of sidewalk; replaced "City Engineer" with "City" in Note 3; removed explanation of right-of-way note; removed zoning setback note; revised note about amenity zone; added note about buffer width; replaced "City Engineer" with "CDOT" in planting strip exception note
23	4/1/2023	U-05D	Commercial Wide Street Typical Section (TDD ONLY)	DETAIL REMOVED
23	4/1/2023	U-06	Local Industrial Street Typical Section	Revised sidewalk width to 6'; adjusted total ROW to back of sidewalk; replaced "City Engineer" with "City" in Note 2; removed explanation of right-of-way note; removed zoning setback note; revised note about amenity zone; added note about buffer width; replaced "City Engineer" with "CDOT" in planting strip exception note
23	4/1/2023	U-07	Local Collector Street Typical Section (Sidewalk)	DETAIL REPLACED WITH U-07A and U-07B
23	4/1/2023	U-07A	Local Collector Street Typical Section (6' Sidewalk)	Added sidewalk width specific to detail; adjusted total ROW to back of sidewalk; removed sidewalk 5' min note; removed SUE callout; removed explanation of right-of-way note; removed zoning setback note; revised note about amenity zone; added note about buffer width; replaced "City Engineer" with "CDOT" in planting strip exception note; replace "City Engineer" with "City" in base course callout
23	4/1/2023	U-07B	Local Collector Street Typical Section (8' Sidewalk)	Added sidewalk width specific to detail; adjusted total ROW to back of sidewalk; removed sidewalk 5' min note; removed SUE callout; removed explanation of right-of-way note; removed zoning setback note; revised note about amenity zone; added note about buffer width; replaced "City Engineer" with "CDOT" in planting strip exception note; replace "City Engineer" with "City" in base course callout

REVISION NO.	REVISION DATE	STANDARD No.	NAME	DESCRIPTION OF REVISION
			Text	Specifications and Special Provisions Notes
				Various updates to Storm Drainage Section II. Rearranged to include general requirements section, and then separate sections for various pipe material types. References updated to NCDOT Roadway Standard Drawings and City of Charlotte separate documents for Post-Installation Inspection and Repair of Storm Drainage Pipes and Culverts, and the Third-Party Inspection for Pipe Installations.
24	4/3/2024			
24	1/31/2024	10.24A	Commercial Type II and Residential Type I Drop Curb Driveway with Sidewalk Abutting Curb	Revised line item in Apron Width table to "Arterial" instead of "throughfare"
24	1/31/2024	10.24B	Commercial Type II and Residential Type I Drop Curb Driveway with Sidewalk Abutting Curb	Revised line item in Apron Width table to "Arterial" instead of "throughfare"
24	1/31/2024	10.24C	Commercial Type II and Residential Type I Drop Curb Driveway with Sidewalk Abutting Curb	Revised line item in Apron Width table to "Arterial" instead of "throughfare"
24	1/31/2024	10.25A	Residential Drop Curb Type I Driveway with Planting Strip (2'-6" Curb and Gutter)	Revised line item in Apron Width table to "Arterial" instead of "throughfare"
24	1/31/2024	10.25C	Residential Drop Curb Type I Driveway with Planting Strip (6"X18" Vertical Curb)	Revised line item in Apron Width table to "Arterial" instead of "throughfare"
24	1/31/2024	10.25F	Commercial Type IV Driveway Standard	Revised line item in Apron Width table to "Arterial" instead of "throughfare"
24	1/31/2024	10.27A	Residential Driveway (Type II) Valley Gutter	Revised line item in Apron Width table to "Arterial" instead of "throughfare"
24	1/31/2024	10.36A	Culvert Crossings on Residential and Commercial Streets	Client 2:1 slope from sidewalk bench to top of pipe. Show grade file to top of endwalls
24	1/31/2024	10.39	Modular Retaining Walls Using Geogrids in the Right Of Way	Revise Note 8 to include storm drainage easements and storm drain pipes
24	1/31/2024	20.00A	NCDOT Standards Approved For Use in the City of Charlotte and Charlotte ETJ	Updated / revised various items to correspond to NCDOT 2024 Roadway Standard Drawings
24	1/31/2024	20.00B	NCDOT Standards Approved For Use in the City of Charlotte and Charlotte ETJ	Updated / revised various items to correspond to NCDOT 2024 Roadway Standard Drawings
24	1/31/2024	20.00C	NCDOT Standards Approved For Use in the City of Charlotte and Charlotte ETJ	Updated / revised various items to correspond to NCDOT 2024 Roadway Standard Drawings
24	1/31/2024	20.30	Minimum Storm Easements Pipe and Channel	Added notes 5 and 6. Re: pipe contact in easement and dual pipe scenarios
24	1/31/2024	21.00	Bio-retention Plan	Revised notes, callouts, etc to correspond to SCM Manual information
24	1/31/2024	21.01	Bio-retention Cross-Section	Revised notes, callouts, etc to correspond to SCM Manual information
24	1/31/2024	21.02	Bio-retention Planting Plan	DETAIL REMOVED - no longer needed
24	1/31/2024	21.04	Flow Splitter	DETAIL REMOVED - no longer needed
24	1/31/2024	21.05	Wetpond Plan	Revised notes, callouts, etc to correspond to SCM Manual information
24	1/31/2024	21.06	Wetpond Profile	Revised notes, callouts, etc to correspond to SCM Manual information
24	1/31/2024	21.07	Wetpond Cross-Sections	DETAIL REMOVED - no longer needed
24	1/31/2024	21.09	Wetpond Planting Plan	DETAIL REMOVED - no longer needed
24	1/31/2024	21.10	Wetland Plan	Revised notes, callouts, etc to correspond to SCM Manual information
24	1/31/2024	21.11	Wetland Section	Revised notes, callouts, etc to correspond to SCM Manual information
24	1/31/2024	21.12	Wetland Cross Sections	DETAIL REMOVED - no longer needed
24	1/31/2024	21.14	Wetland Planting Plan	DETAIL REMOVED - no longer needed
24	1/31/2024	21.15	Enhanced Grass Swale Planting Plan	DETAIL REMOVED - no longer needed
24	1/31/2024	21.16	Enhanced Grass Swale Details	DETAIL REMOVED - no longer needed
24	1/31/2024	21.17	Grass Channel	DETAIL REMOVED - no longer needed
24	1/31/2024	21.18	Grass Channel Planting Plan	DETAIL REMOVED - no longer needed
24	1/31/2024	21.19	Infiltration Trench	Revised notes, callouts, etc to correspond to SCM Manual information
24	1/31/2024	21.21	Buffer Strip	DETAIL REMOVED - no longer needed
24	1/31/2024	21.22	Buffer Strip Planting Plan	DETAIL REMOVED - no longer needed
24	1/31/2024	21.23	Underground Sand Filter	Revised notes, callouts, etc to correspond to SCM Manual information
24	1/31/2024	21.24	Surface Sand Filter	Revised notes, callouts, etc to correspond to SCM Manual information
24	1/31/2024	21.25	Surface Sand Filter Section	Revised notes, callouts, etc to correspond to SCM Manual information
24	1/31/2024	30.00	Erosion Control Standards List & Maintenance References	Replaced old table of EC measures with a new table to list Maintenance References for EC Measures
24	1/31/2024	30.00B	General Notes - Sediment Basins	Revised various notes
24	1/31/2024	30.10C	Temporary Waftle Check Dam with Matting	Revised previous detail to remove "optional PAM"
24	1/31/2024	30.10D	Temporary Waftle Check Dam with Matting and PAM	New detail to show standard including PAM
24	1/31/2024	30.22A	Bypass Pumping	Added note referring to Dewatering Device 30.13
REVISION NO.	REVISION DATE	STANDARD No.	NAME	DESCRIPTION OF REVISION
25	8/31/2025		TEXT	Specifications and Special Provisions Notes
25	8/31/2025	10.24A	Commercial Type II and Residential Type I Drop Curb Driveway with Sidewalk Abutting Curb (2'-6" Curb and Gutter)	Language was updated to implement recent PROWAG updates.
25	8/31/2025	10.24B	Commercial Type II and Residential Type I Drop Curb Driveway with Sidewalk Abutting Curb (6" X 18" Curb and Gutter)	Detail was added regarding the driveway apron requirements.
25	8/31/2025	10.24C	Commercial Type II and Residential Type I Drop Curb Driveway with Sidewalk Abutting Curb (6" X 18" Curb and Gutter)	Detail was added regarding the driveway apron requirements.
25	8/31/2025	10.25A	Residential Drop Curb Type I Driveway with Planting Strip (2'-6" Curb and Gutter)	Detail was added regarding the driveway apron requirements.
25	8/31/2025	10.25B	Residential Drop Curb Type I Driveway with Planting Strip (2'-6" Curb and Gutter)	Detail was added regarding the driveway apron requirements.
25	8/31/2025	10.25C	Residential Drop Curb Type I Driveway with Planting Strip (6" X 18" Vertical Curb)	Detail was added regarding the driveway apron requirements.
25	8/31/2025	10.25D	Commercial Drop Curb Type II Driveway with Planting Strip (6" X 18" Vertical Curb)	Detail was added regarding the driveway apron requirements.
25	8/31/2025	10.25E	Type II Modified Driveway Detail with Wide Planting Strip and Standard Curb	Detail was added regarding the driveway apron requirements.
25	8/31/2025	10.25F	Commercial Type IV Driveway Standard	Detail was added regarding the driveway apron requirements.
25	8/31/2025	10.27A	Residential Driveway (Type II) Valley Gutter	Detail was added regarding the driveway apron requirements.
25	8/31/2025	10.27B	Commercial Type II Driveway For 2'-0" Valley Gutter	Detail was added regarding the driveway apron requirements.
25	8/31/2025	10.28	Type III Driveway Entrance	Detail was added regarding the driveway apron requirements.
25	8/31/2025	10.45A	Truck Apron at Intersection	Red Dye option was removed from the detail and the concrete is required to be naturally colored.
25	8/31/2025	10.45B	Truck Apron at Roundabout	Red Dye option was removed from the detail and the concrete is required to be naturally colored.
25	8/31/2025	21.24	Surface Sand Filter	Clarification added to ensure positive drainage.
25	8/31/2025	30.11A	Stabilized Construction Entrance	Clarified depth and stone size required, added silt fence and maintenance notes.
25	8/31/2025	30.11B	Construction Entrance Tire Wash	Clarified depth and stone size required, added construction and maintenance notes.
25	8/31/2025	30.11C	Single Family Lot Controls	Clarified depth and stone size required and maintenance notes.
25	8/31/2025	30.11D	Urban Block/Lot Controls	New Detail to address erosion control requirements. Provides standard practice related to erosion control requirements for lots/blocks.
25	8/31/2025	40.11	Reinforced Concrete Sidewalk (Bridging Tree Roots)	Detail was updated to accommodate shared-use paths along with sidewalks
25	8/31/2025	50.00D	Accessible On-Street Parallel Parking	Detail was updated to accommodate meet current PROWAG language

Charlotte Land Development Standards Manual

City of Charlotte (Including ETJ) Land Development

Table of Contents

Specifications & Special Provisions

Standard Details:

1000 Series - Miscellaneous Infrastructure Standards

<u>Standard</u>	<u>Description</u>
10.17A	Curb and Gutter
10.17B	Curb and Gutter
10.17C	Curb and Gutter
10.18	Vertical Curb
10.19	Curb Transition 2'-6" To 2'-0" Valley
10.20	Curb Transition 2'-6" To 1'-6" Standard
10.22	Concrete Sidewalks
10.23	Sidewalk Transition
10.24A	Commercial Type II and Residential Drop Curb Type I Driveway with Sidewalk Abutting Curb (2'-6" Curb and Gutter)
10.24B	Commercial Type II and Residential Drop Curb Type I Driveway with Sidewalk Abutting Curb (6"X18" Vertical Curb)
10.24C	Commercial and Residential Drop Curb Driveway with Sidewalk Abutting Curb
10.25A	Residential Drop Curb Type I Driveway with Planting Strip (2'-6" Curb and Gutter)
10.25B	Commercial Drop Curb Type II Driveway with Planting Strip (2'-6" Curb and Gutter)
10.25C	Residential Drop Curb Type I Driveway with Planting Strip (6"X18" Vertical Curb)
10.25D	Commercial Drops Curb Type II Driveway with Planting Strip (6"X18" Vertical Curb)
10.25E	Modified Type II Driveway Detail with Planting Strip
10.25F	Commercial Type IV Driveway Standard
10.27A	Residential Driveway (Type I) Valley Gutter
10.27B	Commercial Type II Driveway For 2'-0" Valley Gutter
10.28	Type III Driveway Entrance
10.29	Catch Basin Frame in Valley Gutter
10.30	Catch Basin Placement in Valley Gutter
10.31A	Perpendicular Curb Ramp with 2'-6" Curb and Gutter
10.31B	Perpendicular Curb Ramp with 2'-6" Curb and Gutter
10.33	Perpendicular Curb Ramp with 2'-0" Valley Gutter
10.35A	Standard Placement of Curb Ramps at Obstructed or Small Corner Radius
10.35B	Truncated Domes Plan and Cross Section
10.36A	Culvert Crossings on Residential and Commercial Streets
10.36B	Culvert Crossings on Residential and Commercial Streets
10.37	Typical Local Residential To Local Limited Street Taper
10.38	Curb Repairs at Bus Stops
10.39	Modular Retaining Walls Using Geogrid in the Right Of Way
10.40A	Directional Curb Ramp with Small/Medium Curb Radii
10.40B	Directional Curb Ramp with Large Curb Radius
10.40C	Directional Curb Ramp with Valley Gutter
10.41A	Pedestrian Refuge (With 1'-6" Curb & Gutter)
10.41B	Pedestrian Refuge (With Vertical Curb)

10.41C	Pedestrian Refuge (Modified Monolithic)
10.42	Shared Use Path (SUP) and Off-Street Path
10.43	Bike Ramp at Shared Use Path
10.44	Tactile Guide Strip
10.45A	Truck Apron at Intersection
10.45B	Truck Apron at Roundabout

1100 Series - Street Section Details

<u>Standard</u>	<u>Description</u>
11.02	Local Residential Typical Ditch Type Street Section
11.07A	Residential Collector Street Ditch Type Typical Section (6' Sidewalk)
11.07B	Residential Collector Street Ditch Type Typical Section (8' Sidewalk)
11.09	Arterial Street Typical Sections
11.13	Private Street Typical Sections
11.14	Divided Private Street Typical Sections
11.16	City of Charlotte and ETJ Residential Cul-De-Sac Detail
11.17	Commercial Cul-De-Sac Detail
11.18A	Residential Hammerhead Detail
11.18B	Temporary Turnaround Local Residential Street (Optional)
11.19A	Residential Alley Detail One Way Operation
11.19B	Residential Alley Detail Double Loaded w/ Two Way Operation
11.19C	Residential Alley Detail Single Loaded w/ Two-Way Operation
11.20	Residential Alley Hammerheads and Intersections
11.21	Oversized Residential Cul-De-Sacs with Raised Planter Island

2000 Series - Storm Drain Standards

<u>Standard</u>	<u>Description</u>
20.00A,B,C	NCDOT Standards Approved For Use in the City of Charlotte and Charlotte ETJ
20.03	Double Brick Catch Basin 15"-36" Pipe
20.05A	Slab Type Catch Basin 15" Thru 48" Pipe
20.05B	Manhole Ring and Cover for Slab Type Catch Basin
20.17A	Concrete Wingwall Splash Pad
20.17B	Concrete Wingwall Splash Pad
20.22	Flared End Section 12" To 72"
20.23	Rip Rap Aprons at Outfalls
20.24	Rip Rap Plunge Pool
20.26	Concrete Paved Ditches
20.28	Subdrain Detail
20.29	Overlapping Sewer and Storm Easements
20.30	Minimum Storm Easements Pipe and Channel
20.34	Offset Catch Basin
20.35	Grading At Yard/Drop Inlet

2100 Series – Stormwater Control Measure (SCM) Details

<u>Standard</u>	<u>Description</u>
21.00	Bioretention Plan
21.01	Bioretention Cross-Section
21.05	Wetpond Plan
21.06	Wetpond Profile
21.07	Wetpond Cross-Sections
21.08	Wetpond Details
21.10	Wetland Plan

21.11	Wetland Section
21.13	Wetland Details
21.19	Infiltration Trench
21.20	Monitoring Well Detail
21.23	Underground Sand Filter
21.24	Surface Sand Filter
21.25	Surface Sand Filter Section

3000 Series - Erosion Control Standards

StandardDescription

30.00	Erosion Control Standards List & Maintenance References
30.01	Temporary Sediment Trap
30.02A	Skimmer Sediment Basin
30.02B	Skimmer
30.03A	Sediment Basin
30.03B	General Notes – Sediment Basins
30.04	Flexible Pipe Slope Drain
30.05	Temporary Silt Ditch
30.06A	Temporary Silt Fence
30.06B	High Hazard Temporary Silt Fence
30.06C	Silt Fence Outlet
30.06D	Super Silt Fence
30.07	Block and Gravel Stone Inlet Protection
30.08	Stone Inlet Protection
30.09	Hardware Cloth and Gravel Inlet Protection
30.10A	Temporary Rock Check Dam
30.10B	Temporary Rock Check Dam with Matting and PAM
30.10C	Temporary Wattle Check Dam with Matting
30.10D	Temporary Wattle Check Dam with Matting and PAM
30.11A	Stabilized Construction Entrance
30.11B	Construction Entrance Tire Wash
30.11C	Single Family Lot Controls
30.11D	Urban Block/Lot Controls
30.12	Gravel and Rip Rap Filter Berm Basin
30.13	Erosion Control Dewatering
30.14	Temporary Stream Crossing
30.15	Catch Basin Inlet Protection
30.16	Slope Stability
30.17	Temporary Seeding Schedule
30.18	Temporary Rolled Asphalt Diversion Berm
30.19	Baffle Installation
30.20	Embankment Matting Detail
30.21	Brick Storm Structure with Temporary Pipe\
30.22A	Bypass Pumping
30.22B	Suspended Bypass Pipe
30.22C	Piped Diversion
30.23	Turbidity Curtain

4000 Series - Tree Standards

StandardDescription

40.01	Tree Planting Detail
40.02	Tree Protection Detail
40.03	Large and Small Maturing Tree Pit with Grate in Sidewalk (Plan)
40.03A	Large and Small Maturing Tree Pit with Grate in Sidewalk (Section)
40.03B	Large and Small Maturing Tree Pit with Grate in Sidewalk (Section)
40.03C	Large and Small Maturing Tree Pit with Grate in Sidewalk (Section)
40.04	Typical Valve and Valve Box Installation
40.05A	Shrub Planting Bed
40.05B	Individual Small Shrub / Tree Planting

40.06	6' Tree Planting Strip UMUD Only
40.08A	Median Greater than 120 Inches Excavation, Drainage and Backfill
40.08B	73 to 120 Inch Median Excavation, Drainage and Backfill
40.08C	48 to 72 Inch Median Excavation, Drainage and Backfill
40.09	Root Flare Depths (Tree Rootball Condition on Trees from Suppliers)
40.11	Reinforced Concrete Sidewalk (Bridging Tree Roots Detail)
40.12	Temporary Tree Protection Detail
40.13	Asphalt Curb Placement at Existing Trees
40.14	Rock Chimney

5000 Series - Miscellaneous Standards

<u>Standard</u>	<u>Description</u>
50.01A	Precast Concrete Pavers for Uptown Streetscape
50.01B	Precast Concrete Pavers for Uptown Streetscape
50.01C	Precast Concrete Pavers for Uptown Streetscape
50.03	Concrete Control Monument
50.04A	Safety Rail
50.04B	Safety Rail Warrants
50.05A	Street Name Sign
50.05B	Street Name Sign
50.06	Street Sign Installation Locations
50.07A	Dead End Street Barricade
50.07B	Dead End Street Barricade General Notes
50.08A	End of Roadway Marker
50.08B	End of Roadway Marker Guard Rail Clamp Installation
50.08C	Street Connectivity Sign for End-of-Road Barricade
50.09A	Parking Standards
50.09B	Parking Standards (Continued)
50.09C	Parallel Parking Standards
50.09D	Accessible On-street Parallel Parking
50.10A	Accessible Parking and Signage Standards
50.10B	Supplemental Van Accessible Sign (R7-8P)
50.10C	Supplemental Accessible Sign
50.11	Signage and Pavement Markings at Roundabouts
50.12	Emergency Vehicle Median Crossover
50.13	Directional Crossover with Raised Medians
50.14	Piano Style Crosswalk
50.15	Raised Crosswalk
50.20	Inverted U Rack Bicycle Parking
50.21	Post and Ring Bike Rack
50.22	Bicycle Lockers

U Series – Standards for Urban Street Design

<u>Standard</u>	<u>Description</u>
U-02A	Local Residential Medium Street Typical Section (6' Sidewalk)
U-02B	Local Residential Medium Street Typical Section (8' Sidewalk)
U-03	Local Residential Wide Street Plan View
U-03A1	Local Residential Wide Street Typical Section (8' Sidewalk)
U-03A2	Local Residential Wide Street Typical Section (6' Sidewalk)
U-03B1	Local Residential Wide Street At Midblock With Curb Extension Typical Section (8' Sidewalk)
U-03B2	Local Residential Wide Street At Midblock With Curb Extension Typical Section (6' Sidewalk)

U-03C1	Local Residential Wide Street At Intersection With Curb Extension Typical Section (8' Sidewalk)
U-03C2	Local Residential Wide Street At Intersection With Curb Extension Typical Section (6' Sidewalk)
U-04A	Local Office/Commercial Narrow Street Typical Section (8' Sidewalk)
U-04B	Local Office/Commercial Narrow Street Typical Section (6' Sidewalk)
U-05	Local Office/Commercial Wide Street Plan View
U-05A1	Local Office/Commercial Wide Street Typical Section (8' Sidewalk)
U-05A2	Local Office/Commercial Wide Street Typical Section (6' Sidewalk)
U-05B1	Local Office/Commercial Wide Street At Midblock With Curb Extension Typical Section (8' Sidewalk)
U-05B2	Local Office/Commercial Wide Street At Midblock With Curb Extension Typical Section (6' Sidewalk)
U-05C1	Local Office/Commercial Wide Street At Intersection With Curb Extension Typical Section (8' Sidewalk)
U-05C2	Local Office/Commercial Wide Street At Intersection With Curb Extension Typical Section (6' Sidewalk)
U-06	Local Industrial Street Typical Section
U-07	Local Collector Street Typical Section
U-07A	Local Collector Street Typical Section (6' Sidewalk)
U-07B	Local Collector Street Typical Section (8' Sidewalk)

CHARLOTTE LAND DEVELOPMENT STANDARDS MANUAL
SPECIFICATIONS AND SPECIAL PROVISION NOTES
Includes ETJ

The following specifications and special provisions are intended to be used in conjunction with Charlotte Land Development Standard Drawings, NCDOT Roadway Standard Drawings, and NCDOT Standard Specifications for Roads and Structures for all development within the City of Charlotte and the City of Charlotte ETJ unless otherwise directed by the City.

I. STREETS

A. GENERAL NOTES

1. All work and materials shall conform to the latest edition of the North Carolina Department of Transportation Standard Specifications for Roads and Structures *unless otherwise specified in this manual*.
2. All asphalt cuts shall be made with a saw when preparing street surfaces for patching or widening strips.
3. Paper joints shall be used to seal the ends of an asphalt pour so that future extensions can be made without causing rough joints.
4. When placing asphalt against existing surfaces, a straight edge shall be used to prevent “humping” at that location.
5. Stone shall be primed if paving is not complete within seven days following stone base approval.
6. Surfaces shall be tacked when asphalt is being placed over existing asphalt streets or adjoining concrete, storm drain and sanitary sewer structures.

7. In rolling and hilly terrains, sweeping of the stone base and/or application of a tack coat may be required near intersections. These requirements will be established by the City Inspector based on field conditions.
8. ALL concrete used for streets, curb and gutter, sidewalks and drainage structures, etc. shall have a minimum compressive strength of 3600 PSI at 28 days. This requirement shall be met regardless of any lesser compressive strength specified in the North Carolina Department of Transportation Standard Specifications for Roads and Structures. The contractor shall prepare concrete test cylinders in accordance with Section 1000 of the North Carolina Department of Transportation Standard Specifications for Roads and Structures at the direction of the project inspector. All equipment and cylinder molds shall be furnished by the contractor. It shall be the responsibility of the contractor to protect the cylinders until such time as they are transported for testing. Testing for projects shall be performed by an independent testing lab, at no cost to the City. The contractor shall provide equipment and perform tests on concrete for a maximum slump and air content as defined in Section 1000 of the North Carolina Department of Transportation Standard Specifications for Roads and Structures. These tests shall be performed at a frequency established by the inspector. Materials failing to meet specifications shall be removed by the contractor.
9. All concrete shall be cured with 100% Resin Base, white pigmented curing compound which meets ASTM Specifications C-309, Type 1, applied at a uniform rate at one (1) gallon to 400 square feet within 24 hours of placement of the concrete.
10. All curb and gutter shall be backfilled with soil approved by the Inspector within 48 hours after construction to prevent erosion.
11. All backfill shall be non-plastic in nature, free from roots, vegetative matter, waste, construction material or other objectionable material. Said material shall be capable of being compacted by mechanical means and the material shall have no tendency to flow or behave in a plastic manner under the tamping blows or proof rolling.
12. Materials deemed by the Inspector as unsuitable for backfill purposes shall be removed and replaced with select backfill material.

13. All trenches in the street right-of-way shall be backfilled with suitable material immediately after the pipe is laid. The fill around all pipe shall be placed in layers not to exceed six (6) inches and each layer shall be compacted thoroughly. For Storm Drainage see Backfill under Storm Drainage section.
14. Under no circumstances shall water be permitted to rise in un-backfilled trenches after the pipe has been placed.
15. Compaction requirements shall be attained using mechanical compaction methods. Each six (6) inch layer of backfill shall be placed loose and thoroughly compacted into place.
16. Straight forms shall not be used for forming curb and gutter in curves.
17. All excess concrete on the front edge (lip) of gutter shall be removed when curb and gutter is poured with a machine.
18. All subgrade shall be compacted to 100% of the maximum density obtainable with the Standard Proctor Test to a depth of eight (8) inches, and a density of 95% Standard Proctor for depths greater than eight (8) inches. All tests shall be performed by developer at no cost to the City.
19. A canvas cover or other suitable cover shall be required for transporting plant mix asphalt during cool weather when the following conditions are present:
 - a. Air temperature is below 60 degrees F.
 - b. Length of haul from plant to job is greater than five (5) miles.
 - c. Other occasions at the Inspector's discretion when a combination of factors indicates that material should be covered in order to assure proper placement temperature.
20. Concrete or asphalt shall not be placed until the air temperature measured at the location of the paving operation is at 35 degrees F and rising by 10:00 a.m. Concrete or paving operations should be suspended when the air temperature is 40 degrees F and descending. The contractor shall protect freshly placed concrete or asphalt in accordance with Sections 420 (Concrete Structures), 600 (Asphalt Bases and Pavements), and 700 (Concrete Pavements and Shoulders) of the North Carolina Department of Transportation Standard Specifications when the air temperature is at or below 35 degrees F and the concrete has not obtained an age of 72 hours.

21. The contractor shall always maintain two-way traffic when working within existing streets. The contractor shall place and maintain signs, danger lights, and barricades and furnish watchmen or flagmen to direct traffic in accordance with the latest edition Work Area Traffic Control Handbook (WATCH), Work in the right-of-way of State System Streets may require additional traffic control provisions.
22. The contractor shall do that which is necessary to control erosion and to prevent sedimentation damage to all adjacent properties and streams in accordance with the appropriate City of Charlotte Erosion and Sedimentation Control Ordinance.

B. STANDARDS OF STREET DESIGN

Note: Use of Hilly Terrain criteria is NOT permitted without PRIOR approval of the Director of Transportation.

Note: Design standards that apply for the ETJ are taken from the July 2020 edition of the NCDOT Subdivision Manual. Any revisions to Subdivision Manual will supersede the design standards given in the Charlotte Land Development Standards for ETJ streets. However, under no circumstances shall an NCDOT/ETJ standard be less restrictive than what is required by the City of Charlotte.

1. STREETS (PUBLIC and PRIVATE):

	ALL LOCAL STREETS (Except Industrial & Collector)		LOCAL INDUSTRIAL AND COLLECTOR ONLY	
	<u>Level/Rolling</u>	<u>Hilly</u>	<u>Level/Rolling</u>	<u>Hilly</u>
a. Terrain Classification	0%-15%	15%+	0%-15%	15%+
b. Maximum Grade	10%	12%	8%	10%+
c. Design Speed (mph)	25	20	30	25
d. Minimum Radius (ft.)				
Public Street	150	90	250	175
Private Street	50	50	150	150

	ALL LOCAL STREETS (Except Industrial & Collector)		LOCAL INDUSTRIAL AND COLLECTOR ONLY	
	<u>Level/Rolling</u>	<u>Hilly</u>	<u>Level/Rolling</u>	<u>Hilly</u>
e. Min. Tangent between Horizontal Reverse Curves (ft.)	50	50	100	100
f. K Value (CREST/SAG)	20/20	15/20	28/35	20/20
K Value (STOP Condition)	9	5	14	9

Note: K=Rate of Vertical Curvature for Minimum Sight Distance. Provisions of adequate stopping sight distance may require use of larger K values than the minimums listed above. The Charlotte Department of Transportation, under Section 19-245 of City Code, reserves the right to prescribe more stringent sight distance standards and/or means to achieve adequate sight distance than these listed above.

2. INTERSECTIONS:

a. Maximum Street Grade at Intersections ^{a,b}

STOP or YIELD Condition: Vertical alignment is 2.10% maximum through the crosswalk areas (marked or unmarked). Outside of the crosswalk areas the vertical alignment is 5% maximum within 100 feet of an intersection ^c

UNCONTROLLED APPROACH Condition: Vertical alignment is 5% maximum through the crosswalk areas. Where feasible, it is recommended that the vertical alignment for a through-movement street also be set at 2.10% maximum through the crosswalk areas (marked or unmarked). Outside of the crosswalk areas, see B.1.b for maximum grade.

b. Midblock Pedestrian Street Crossings: At midblock crossings, the cross slope of the pedestrian street crossing is allowed to equal the street grade

c. Minimum Angle of Intersection is 75 degrees

d. See Charlotte Unified Development Ordinance Section 31.3.D for intersection sight distance requirements.

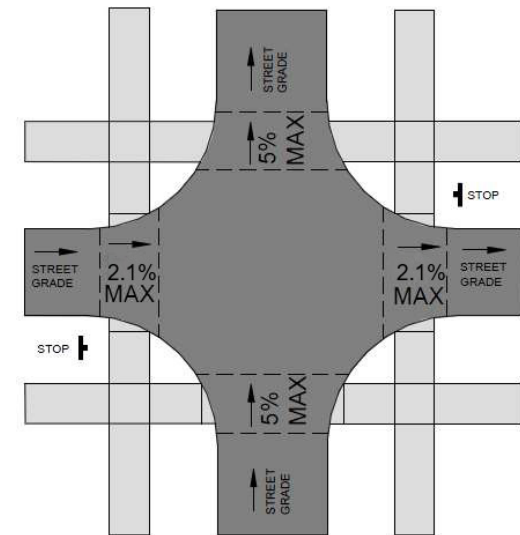

- a Preferred option: Design intersections with a max. 2.10% street grade through the crosswalk area of all legs of the intersection. This will provide a level intersection where the required sidewalks, curb ramps, and street crossings can be constructed with the use of CLDSM standard details included in the plans. Special attention to drainage design is warranted to ensure that these intersections drain properly. For intersections with street grades greater than 2.10% in any direction it is strongly recommended that the sidewalks, curb ramps, and street crossings be included as part of the design process and site-specific details of the designs and any alternate layouts shall be included in plans as appropriate.
- b Refer to Charlotte Unified Development Ordinance Section 31.1.D regarding potential modification of required street spacing and stub street requirements in areas of steep slopes.
- c 100' is the standard for Level/Rolling Terrain. In areas classified as Hilly Terrain, 100' is preferred length, but 40' minimum may be approved by the Director of Transportation. This only applies within the City of Charlotte limits and not in the ETJ, where NCDOT vertical alignment criteria would govern.

(Please note: Modifications to standards as noted in ^b and ^c or the use of "Hilly Terrain" street alignment criteria are typically requested via a subdivision sketch plan submittal. The sketch plan submittal must contain sufficient information to support the request for modified standards. For example, modification requests based upon topographical constraints should include existing and proposed street profiles.)

- e. Minimum Curb & R/W Radius = Taken from Appendix C (Curb Return Radii Guidelines) of USDG

Table 4 - Curb Radii for Local Street Intersections

From/To	R/Medium	R/Wide	C/Narrow	C/Wide	Industrial
R/Medium	15				
R/Wide	15	10			
C/Narrow	15	25	35		
C/Wide	15	15	30	10	
Industrial	25	15	40	25	50
R=Residential					
C=Commercial					

- f. Minimum Intersection Separation.
- | | |
|--------------------------------|--------------------------|
| Along local streets | 125 feet |
| Along collector streets | 200 feet |
| Along arterials/Uptown Streets | To be determined by CDOT |

Intersection offsets/separation from a thoroughfare, at signalized intersections, or at intersections that may become signalized in the future may need to be greater than these minimums and will be determined by CDOT on a case by case basis.

- Design criteria for arterial streets shall be established by the Director of the Department of Transportation on a case by case basis using the latest edition of the American Association of State Highway and Transportation Officials (AASHTO) A Policy on Geometric Design of Highway and Streets and/or NCDOT Roadway Design Manual.
- Intersection corner – A minimum 50' x 50' sight triangle (measured along back of curb or edge of pavement) shall be provided at each intersection corner. An additional 10' x 70' sight triangle shall be provided at intersections connecting to NCDOT maintained roadways. Other sight distance requirements may be required by the NCDOT or CDOT per the Charlotte Unified Development Ordinance (UDO) Section 31.3.D.
- Refer to the NCDOT Subdivision Roads Minimum Construction Manual for development criteria for sites located within the City of Charlotte Extraterritorial Jurisdiction (ETJ) within these areas governed by Charlotte Land Development Standards Manual and the NCDOT Subdivision Roads Minimum Construction Standards Manual. The more restrictive standard shall apply.

C. GRADING

1. Proposed street rights-of-way shall be graded to their full width for ditch type streets and a minimum of eight (8) feet behind the curb for curb and gutter sections.
2. Fill embankments shall be formed of suitable material placed in successive layers not to exceed more than six (6) inches in depth for the full width of the cross-section, including the width of the slope area. No stumps, trees, brush, rubbish or other unsuitable materials or substances shall be placed in the embankment. Each successive six (6) inch layer shall be thoroughly compacted by the sheepfoot tamping roller, 10-ton power roller, pneumatic-tired roller, or other methods approved by the City. Embankments over and around all pipe culverts shall be of select material, placed, and thoroughly tamped and compacted as directed by the City.

D. ROADWAY BASE

1. All roadways shall be constructed with a base course as described on the appropriate Charlotte Land Development Standard Detail Drawing.
2. The material for stone base course shall conform to the requirements of Section 1010, Aggregate for Non-Asphalt Flexible Type Base, and Section 520, Aggregate Base course of the North Carolina Department of Transportation Standard Specifications for Roads and Structures.
3. The stone base shall be compacted to 100% of the maximum density obtainable with the Modified Proctor Test (AASHTO-T180) by rolling with ring or tamping roller or with a pneumatic tired roller with a minimum weight of ten tons. When completed, the base course shall be smooth, hard, dense, unyielding and well bonded.
4. A bituminous concrete base course, as specified on the Standard Detail Drawing may be substituted in lieu of a stone base course.
5. Asphalt base course will only be allowed within widening strips less than five (5) feet in width.

E. ROADWAY INTERMEDIATE AND SURFACE COURSE

1. All public roadways shall be constructed with an intermediate and surface course as described on the appropriate City of Charlotte Land Development Standard Detail Drawing.
2. Plant mixed asphalt shall conform in all respects to Section 610 of the North Carolina Department of Transportation Standard Specifications for Roads and Structures.
3. The final (1) one inch lift of asphalt surface course for Residential Subdivision Streets shall be withheld until a minimum of (75%) Seventy-Five Percent of the Development is occupied (occupied means a certificate of occupancy has been issued) or at least (1) one year has lapsed from the application of the intermediate course layer (All documentation to be provided by the developer and approved by the City Inspector). All known base failures shall be repaired prior to application of the final one inch lift of asphalt surface course.
4. The City inspector shall be given a (24) twenty-four-hour notification to inspect the intermediate course deficiencies. All deficiency repairs are to be monitored by a City Inspector and accepted prior to application of final layer.
5. City inspectors shall be notified prior to using recycled plant mixes.
6. Failure to meet the above requirements may result in the delay or prevention of street acceptance by the City of Charlotte or NCDOT.

F. SIDEWALKS, RAMPS, AND DRIVEWAYS

1. Where sidewalks and pedestrian routes within street crossings (including marked and unmarked crosswalks) are provided, they must be constructed so they are accessible to all potential users, including those with disabilities.

All pedestrian facilities within the public right of way are to be designed per requirements of the latest Public Right-of-Way Accessibility Guidelines (PROWAG). The designer is encouraged to reference the complete PROWAG document for additional information (www.accessboard.gov). Buildings and other structures not covered by PROWAG must comply with the applicable requirements of the ADAAG.

2. Sidewalks shall be constructed of not less than 3600 P.S.I. concrete and shall be four (4) inches thick, constructed on an adequately graded base, except where a sidewalk crosses a driveway it shall be six (6) inches thick. Subgrade shall be compacted to 95% of the maximum density obtainable with the Standard Proctor Test. The surface of the sidewalk shall be steel trowel and light broom finished and cured with an acceptable curing compound. Tooled joints shall be provided at intervals of not less than five (5) feet and expansion joints at intervals of not more than forty-five (45) feet. The sidewalk shall have a desired lateral slope of 1.5% (2.10% maximum).

EXAMPLE SIDEWALK CONSTRUCTION DIMENSIONS:		
WIDTH	RISE	CROSS-SLOPE
4'	¾"	1.56%
5'	1"	1.67%
6'	1-1/8"	1.56%
8'	1-½"	1.56%

3. Planting strip adjacent to sidewalk shall be graded to ¼ inch per foot (min.) up to 1 ¼ inch per foot (max.), except where excessive natural grades make this requirement impractical. In such cases, the City may authorize a suitable grade.
4. Sidewalk widths shall be a minimum of five (5) feet unless otherwise specified. Where necessary, a 5' x 5' sidewalk is required at least every 200' as required by PROWAG for a passing zone unless otherwise provided by residential driveways, intersecting sidewalk, etc.
5. Approval of sidewalk construction plans must be obtained as part of the plan review process. Except in unusual circumstances, sidewalk must be located a minimum of (8) eight feet from the back of the curb or at the back of the right-of-way. A recorded public sidewalk easement is required for all sidewalk located outside public right-of-way; the width shall be equal to the distance from the right-of-way line to the back of the sidewalk plus two feet or to the face of building, whichever is less. The sidewalk easement must be recorded with the Mecklenburg County Register of Deeds prior to issuance of a certificate of occupancy for the corresponding building(s).
6. Running slope of all ramps shall be up to 7.5% (8.3% maximum). Ramp length is not required to exceed 15' regardless of the resulting slope, which shall be uniform for the length of the ramp. Curb ramps are required where sidewalks intersect curbing at any street intersection and at Type III driveway connections.
7. For City projects only: On CLDS# 10.24A/B/C, 10.25(A/B/C/D only), and 10.27A/B, the curb and gutter across the front of the driveway shall be measured and paid for separately under Curb and Gutter (either 2'-0" valley gutter, vertical curb, or standard 2'-6" curb and gutter as specified on the details). The curb and gutter is to be measured per linear foot along the surface of the top of the curb. The concrete driveway apron is to be measured per square yard.

8. Refer to the WATCH Manual, MUTCD (latest edition), and the PROWAG (latest edition) for construction zone pedestrian routes and signalization and controls for actuators. Curb ramps shall be designed and constructed in accordance with PROWAG.
9. Where pedestrian routes are contained within a street or right-of-way, the grade of pedestrian access routes shall not exceed the general grade established for the adjacent street or highway.

II. STORM DRAINAGE

A. GENERAL NOTES

1. Unless otherwise specifically set forth herein, all materials, methods of construction and workmanship for the work covered in reference to stormwater infrastructure construction shall conform to the most recent Standards and Specifications of the North Carolina Department of Transportation (NCDOT).
2. Refer to NCDOT Pipe Material Selection Guide for allowable pipe fill heights and specifications. For fill heights less than 2' (measured from top of pipe to bottom of pavement structure) Class IV/Class V Reinforced Concrete Pipe (RCP) will be required. Designs outside of the selection guide will be approved at the discretion of Charlotte Storm Water Services.
3. All pipes must be sourced through an NCDOT approved producer/supplier and they must participate in the NCDOT QA/QC program for each respective pipe material.
4. Reinforced Concrete Pipe (RCP) may be used in all storm drainage and culvert applications.
5. High Density Polyethylene (HDPE) Pipe may be substituted for pipe diameters of 48" or less but shall not be allowed in culvert applications or installations within an arterial street Right of Way maintained by the City of Charlotte.
6. Corrugated Aluminized Metal Pipe (CAMP) or Corrugated Aluminum Alloy Pipe (CAAP) may only be used in roadway culvert applications requiring 60" or larger pipe diameters. Culverts are defined as open-ended conduits passing through roadway embankments. CAMP and/or CAAP shall not be used in piped storm drainage collection systems that connect to drainage structures, multiple systems, system outlets, etc.
7. Pipes shall have a minimum diameter of fifteen (15) inches (eighteen (18) inches minimum on culverts).
8. The maximum allowable pipe slope is 10 percent.
9. All pipes, regardless of material shall have all joints wrapped with a geotextile fabric (NCDOT Section 1056 – Type 2). Geotextile must extend 12" past each side of joint and edges of bands. Geotextile must be secured to the outside of pipe by methods indicated by engineer.

10. All concrete used for drainage structures shall have a minimum compressive strength of 3600 PSI at 28 days. This requirement shall be provided regardless of any lesser compressive strength specified in the North Carolina Department of Transportation Standard Specifications for Roads and Structures.
11. Prior approval by Charlotte Storm Water Services shall be required for the construction of any endwall that is not a NCDOT Roadway Standard Drawing.
12. All graded creek banks and cut/fill slopes shall be at a maximum of two (2) feet horizontal to one (1) foot vertical (2:1) and not to exceed 10' without terracing or the slopes shall be designed by a Professional Geotechnical Engineer and approved by Charlotte Storm Water Services on a case-by-case basis.

B. STANDARDS FOR DESIGN

1. In accordance with Charlotte Unified Development Ordinance Articles 24 and 25, Charlotte Storm Water Services shall review the drainage plan for compliance with the standards contained in the current edition of the Charlotte Land Development Standards Manual, the Charlotte-Mecklenburg Storm Water Design Manual and all other relevant and appropriate standards established by the City.
2. All storm drainage design shall conform to the standards and specifications as provided in the Charlotte-Mecklenburg Storm Water Design Manual, North Carolina Department of Transportation Standards Specifications for Roads and Structures, and the Charlotte Land Development Standards Manual. In the event of conflicting standards, the more restrictive shall apply.
3. The NCDOT Roadway Standard Drawings have been accepted as approved standards for Land Development projects in the City of Charlotte and City of Charlotte ETJ. See standard #20.00A, B, and C of this manual for a table listing the standards accepted. These standard drawings shall be referenced by NCDOT number or shown on all plans submitted to the City of Charlotte for approval.
4. Culverts must be long enough to accommodate the proposed roadway section with a 2:1 fill slope, or flatter, measured from shoulder point and/or back of grade bench to the toe of slope. Extend the pipe to allow the endwall to be placed at the toe of slope. See CLDSM 10.36A.
5. Endwalls or other end treatments are required on all culverts and at the outlet end of all closed pipe systems. Endwalls are required for pipes 36" and larger.
6. Construct endwalls perpendicular to the centerline of the pipe unless specific site conditions warrant construction of an endwall parallel to the roadway.

7. Sub-surface drainage shall be provided where the ground water level is likely to be near the surface. In capillary soils, the water level should be four (4) to six (6) feet below the surface to prevent the rise of moisture into the subgrade. Subdrains shall be used to lower ground water in low areas in the street.

C. PIPE INSTALLATION

1. All pipe materials referenced herein shall be installed pursuant to Section 300 of the current version of the NCDOT Standard Specifications for Roads and Structures, Pipe installation and 300.01 of the NCDOT Roadway Standard Drawings for method of pipe installation.
2. Storm drainage pipe shall be placed in a straight alignment at uniform grade. All pipes shall be laid with the bell or groove up grade and the joint entirely interlocking.
3. No changes in alignment shall be allowed except at catch basins, manholes, or other junctions that provide appropriate clean out access. The maximum length between access points is 300 linear feet.
4. Each run of pipe (structure to structure) shall be a single type, class, and material.
5. An NCDOT standard pipe collar or drainage structure is required where pipes from differing manufacturers or materials are joined. Pipes should be on the same grade and alignment and have the same internal diameter where a pipe collar is specified.
6. Lift holes, if present on Reinforced Concrete Pipe, are to be repaired per 300-6 (A) of the NCDOT Standard Specifications for Roads and Structures. Alternate repair methods must be submitted to Storm Water for approval prior to construction. Repair must meet or exceed acceptable leakage rates for the pipe joints.
7. All installations of storm drainage infrastructure associated with the subdivision ordinance, unified development ordinance and/or any system conveying runoff into or from a public right of way will require a Closed-Circuit Television (CCTV) inspection and/or Confined Space Entry (CSE) to verify infrastructure was installed correctly and is free of defects and excessive deflection. This inspection should occur after backfilling is completed to final grade but prior to completion of paving operations. See City of Charlotte *Post Installation Inspection and Repair of Storm Drainage Pipes and Culverts* for additional information.
8. All flexible pipe, reinforced concrete box culverts, and arch culvert installations require third-party inspection. All inspections shall be performed by a licensed, competent third-party inspection firm and the inspections shall be directed or performed by a North Carolina Professional Engineer. Inspections shall be completed as described in the most recent version of the City of Charlotte Storm Water Services document *Third-Party Inspection for Pipe Installation*.

D. BACKFILL

1. Backfilling of pipe trenches and excavations for drainage structures shall be in accordance with NCDOT standards. Layers shall not exceed six (6) inches loose and each layer shall be compacted thoroughly to the required density of 95% standard proctor density.
2. All backfill shall be non-plastic in nature, free from roots, vegetative matter, waste, construction material or other objectionable material. Said material shall be capable of being compacted by mechanical means to the required density and the material shall have no tendency to flow or behave in a plastic manner under the tamping blows or proof rolling.
3. Materials deemed by the Engineer as unsuitable for backfill purposes shall be removed and replaced with select backfill material.
4. Backfilling of trenches shall be accomplished immediately after the pipe is laid. Do not operate heavy equipment over any pipe or culvert until the pipe or culvert has been properly backfilled and covered with at least three (3) feet of an approved material.
5. Under no circumstances shall water be permitted to rise in un-backfilled trenches after the pipe has been placed.

E. STANDARD PIPE MATERIAL REQUIREMENTS

1. Reinforced Concrete Pipe – RCP
 - a. Pipe shall be manufactured in accordance with AASHTO M-170 and/or ASTM C-76. Class of pipe and wall thickness shall be in accordance with the most recent version of the NCDOT Pipe Material Selection Guide. Pipe shall have 8-foot standard joint lengths. Unless a leak resistant joint is specified, preformed joint sealant conforming to ASTM C-990 shall be used.
 - i. Installation of Class IV or higher concrete pipe shall be identified on the design plans. The City inspector shall be given documentation and notification of this information prior to construction. Registered professional shall note on As-Builts that the appropriate class/type of pipe was installed.

F. ALTERNATIVE PIPE MATERIALS AND DESIGN SPECIFICATIONS

1. Performance Pipe Joints - Where reinforced concrete pipes (RCP) and/or culverts are subject to operating under pressure during the design storm event, as defined within the Charlotte Mecklenburg Storm Water Design Manual, an upgraded performance joint design will be required.
 - a. Leak Resistant Joint – Limited leakage is acceptable.

- i. All joints shall be bell and spigot type, with a rubber gasket conforming to ASTM C-443. Pipe shall be manufactured in accordance with AASHTO M-170 and/or ASTM C-76. Class of pipe and wall thickness shall be in accordance with the current version of the NCDOT Pipe Material Selection Guide.
- b. Special Design Joint – Limited leakage is not acceptable.
 - i. Manufacture provided design will be required.

2. Corrugated Aluminized Steel Pipe and Corrugated Aluminum Alloy Pipe

- a. Aluminum coated (Type 2) steel pipe shall comply with AASHTO M-274 for the coating and AASHTO M-36 for the pipe fabrication. Aluminum alloy pipe shall comply with AASHTO M-196 for material and fabrication.
- b. Where velocities within the pipe exceed 5 ft/sec for the 2-year storm, field pave a 4-inch-thick reinforced concrete invert, 2/5 of the height of the culvert or .5' above the flow height of the 2-year event, whichever is more restrictive. Allowable velocities for the design storm event shall not exceed 10 feet/sec. Invert shall not be constructed until pipe backfill is completed.
- c. Prior to installation, pH, and resistivity testing of the proposed backfill material is required at two or more locations along the proposed pipe alignment.
 - At a minimum, for CAMP and CAAP to be considered, soil and stream-side pH and resistivity values must be within a range of $5.0 < \text{pH} < 9.0$ and resistivity of $r > 1500$ ohm-cm.
 - Submit manufactures specifications showing that the selected CAMP or CAAP is suitable based on the results of the physical testing of pH and resistivity.
- d. Minimum wall thickness is 10 gage.
- e. Each pipe section shall be joined to the next by a coupling band with a minimum of one corrugation overlap at each edge. The coupling bands shall have a minimum of two annular corrugations and fully engage, over the entire pipe periphery, one corrugation on each pipe. Bands shall be fabricated from the same material as the pipe. The minimum band gauges for aluminum pipe and aluminized pipe shall be as specified in AASHTO M-196 and AASHTO M-274, respectively.
- f. Gaskets that provide a leak resistant joint are required and shall be either sleeve type or O-ring type and shall meet the requirements for gaskets as specified in AASHTO M-36, Section 9.3
- g. Where Aluminum or Aluminized metal pipe is in direct contact with concrete a barrier coating must be applied. See NCDOT Thermal Spray Coatings Program for acceptable treatments.

3. Corrugated Aluminized Steel and Corrugated Aluminum Alloy Arches and/or Plate
 - a. Corrugated aluminum alloy structural plate pipe, pipe arches and arches shall consist of aluminum plates and galvanized bolts and nuts of the size, shape and thickness as shown on the approved plans. These structures shall conform to the requirements of AASHTO M-219.
 - b. Where velocities within the pipe/arch exceed 5 ft/sec for the 2-year storm, the walls of the culvert should be protected from abrasion by applying a 4-inch-thick reinforced concrete barrier, $\frac{2}{5}$ of the height of the culvert or .5' above the flow height of the 2-year event, whichever is more restrictive. Allowable velocities for the design storm event shall not exceed 10 feet/sec. Barrier shall not be constructed until pipe backfill is completed.
 - c. Prior to installation, pH, and resistivity testing of the proposed backfill material is required at two or more locations along the proposed pipe alignment.
 - i. At a minimum, for CAMP and CAAP to be considered, soil and stream-side pH and resistivity values must be within a range of $5.0 < \text{pH} < 9.0$ and resistivity of $r > 1500$ ohm-cm.
 - ii. Submit manufactures specifications showing that the selected CAMP or CAAP is suitable based on the results of the physical testing of pH and resistivity.
 - d. Minimum wall thickness is 10 gage.
 - e. Gaskets that provide a leak resistant joint are required and shall be either sleeve type or O-ring type and shall meet the requirements for gaskets as specified in AASHTO M-36, Section 9.3.
 - f. Where Aluminum or Aluminized metal pipe is in direct contact with concrete a barrier coating must be applied. See NCDOT Thermal Spray Coatings Program for acceptable treatments.
4. High Density Polyethylene Pipe - HDPE
 - a. This type of pipe shall comply with AASHTO M-294, Type S for pipe manufacturing.
 - b. The bell and spigot joint shall have an O-ring gasket meeting ASTM F477 with the gasket factory installed, placed on the spigot end of the pipe. Pipe joints shall meet all requirements of AASHTO M294.
 - c. The minimum length of HDPE pipe permitted for use shall be four (4) feet
5. Reinforced Concrete Box Culverts (RCBC)
 - a. All RCBC must have direct access points into the culvert. Catch Basins, Manholes or Junctions that connect to the culvert via small diameter pipes will not be considered acceptable access points.
 - b. ALL RCBC must be designed with leak resistant joints. A preformed joint sealant used with an external sealing band is acceptable.
6. Bottomless/Arch Culverts
 - a. All bottomless/arch culvert must be designed with leak resistant joints. A preformed joint sealant used with an external sealing band is acceptable.
 - b. If shallow, non-erosive bedrock is found three feet or less below the streambed, proposal of a bottomless (three-sided) culvert may be considered.

- i. A geotechnical report signed and sealed by a North Carolina Professional Engineer stating that the entire length of the culvert will be bedded on non-erosive bedrock is required.
- ii. Reinforced concrete footings designed by a North Carolina Professional Engineer tied to the bedrock are required.

G. DRAINAGE STRUCTURES

1. All structures and associated frames, grates and lids must comply with current NCDOT standard details and specifications.
2. All storm drain structures over three (3) feet and six (6) inches in height must have steps which comply with NCDOT 840.66.
3. The interior surfaces of all storm drainage structures shall be pointed up and smoothed to an acceptable standard using mortar mixed to manufacturer's specifications. All pipes shall be cut flush within the interior structure wall.
4. All frames, grates, rings, covers, etc., must conform to the standards set forth in this manual. Supply covers with a minimum of two and a maximum of six 1" diameter vent holes.
5. No Blind/Inaccessible structures will be allowed.
6. Waffle and knockout boxes are prohibited on storm drainage systems within and/or conveying runoff from the public right-of-way. Boxes with pre-cast openings shall be used.
7. Joints/Sections of pre-cast structures shall use flexible sealants meeting ASTM C990 or rubber gaskets meeting ASTM C443. Sealant type should meet or exceed allowable leakage rates for pipe joints.
8. Drainage structures accepting flexible pipes (HDPE, CAMP, CAAP, etc) must provide a resilient connection conforming to ASTM C923 and ASTM C1478.
9. Where Aluminum or Aluminized metal pipe is in direct contact with concrete a barrier coating must be applied. See NCDOT Thermal Spray Coatings Program for acceptable treatments.

H. END TREATMENTS:

1. Endwalls are to be NCDOT standard precast concrete, brick masonry with reinforced concrete footings, or cast-in place, reinforced concrete with reinforced concrete footings.
2. No metal or plastic end treatments are allowed.
3. Where Aluminum or Aluminized metal pipe is in direct contact with concrete a barrier coating must be applied. See NCDOT Thermal Spray Coatings Program for acceptable treatments.

I. NON-STANDARD STRUCTURES

1. Any non-standards structures must have prior approval by Charlotte Storm Water Services and will require a sealed design by a North Carolina Professional Engineer.

III. PLAN REQUIREMENTS

A. GENERAL NOTES

1. All erosion control measures shall conform to the standards set forth in the Charlotte Land Development Standards Manual, State of North Carolina Erosion and Sediment Control Planning and Design Manual, or the more restrictive of any standards that conflict.
2. All storm drainage design shall conform to the standards and specifications as provided in the Charlotte-Mecklenburg Storm Water Design Manual, Charlotte Land Development Standards Manual, or the more restrictive of any standards that conflict.
3. The following note shall be placed on all site plans, grading plans, and plats.
 - a. The purpose of the Storm Drainage Easement (SDE) is to provide storm water conveyance. Buildings are not permitted in the easement area. Any other objects which impede storm water conveyance or system maintenance are also prohibited.
4. Cite all appropriate standard detail numbers for any structures or specifics used within the plans in reference to the most current copy of the Charlotte Land Development Standards Manual.
5. In areas where the Floodway Regulations are applicable, the Future Conditions Flood Fringe Line, FEMA Flood Fringe Line, Community Encroachment Line, and FEMA Encroachment Line shall be shown on the preliminary plan and the final plat. An application for a Floodplain Development Permit shall be submitted to Mecklenburg County Land Use and Environmental Services (LUESA) in accordance with the requirements set forth in the City/County Floodplain Regulations.

B. EASEMENTS

1. Storm Drainage Easements (SDE) shall be provided for all storm drainage pipes and channels that are installed and/or modified by a developer (builder, property owner, etc.) and convey runoff into or from a public right of way. See CLDSM 20.30 for additional information.
2. Overlapping of storm drainage easements shall be approved at the discretion of Charlotte Storm Water Services.
3. Storm Drainage Easements shall include all end treatments and energy dissipators, lengthen or widen as needed.

C. SUBDIVISIONS -PRELIMINARY PLAN

1. The preliminary plan must include, at a minimum, the information described in Sections 30.4 and 30.6 of the City of Charlotte Unified Development Ordinance.

D. BOND POLICY – SUBDIVISION IMPROVEMENTS

1. Release of the final subdivision plat will not occur until the improvements required for the area of the final plat are constructed and a final inspection has been performed and found to be in conformance with the plans approved by the Charlotte-Mecklenburg Planning Commission., or a security has been posted with the Land Development Bond Coordinator of the applicable department and all required documents are received in their entirety.
2. The security shall be posted and remain in force until the construction is complete and found to be in conformance with the plans approved by the Charlotte-Mecklenburg Planning Commission. The security will be reevaluated after one year from the date of posting.
3. The Applicant shall notify the City that construction is complete according to the appropriate subdivision ordinance and the Charlotte Land Development Standards Manual before any security will be released. A final inspection will be made to check completeness of the project upon notification.
4. One type of security may be replaced by another type of security in certain situations. The amount of the replacement security will be based on the City's estimate of the work remaining. If the estimate of work results in a lower amount, the replacement security will be treated as a reduction. Certain situations will require an increase in a security and in such cases the replacement security shall be required to equal the higher amount.
5. A one-time reduction in security will be allowed if requested in writing by the principal party of the security. However, the security shall never be less than \$10,000 for the City of Charlotte unless approved by the City.

IV. APPROVED PLANT SPECIES

The following list of trees and shrubs represent the approved plant species that may be used to comply the City of Charlotte Unified Development Ordinance ("Tree Ordinance" section) of the City of Charlotte Code.

Other species may be allowed with staff approval

List subject to change

- * - Not allowed for required city planting.
- ** - Not recommended for required city planting.
- † - Cultivars under 15' tall only.
- ‡ - Trees <25' mature height can be planted directly under power lines.
Trees 25' - 40' mature height can be planted at least 20' from power lines.

Trees		City Tree Ordinance Approved	CIP/ROW Approved	City Zoning Approved (Large or Small Maturing)	Duke Transmission Zone (T) or Distribution line (D) Approved	Shade Tolerant	Tolerates Poor Drainage	Native	Blooming	Foliage (Deciduous, Semi-deciduous, or Evergreen)
Common Name	Scientific Name									
LARGE MATURING (50'+ H)										
Arborvitae, 'Green Giant'	Thuja 'Green Giant'		x				x			E
Ash, Green	Fraxinus pennsylvanica			L		x		x		D
Ash, White	Fraxinus americana	x		L				x		D
Baldcypress	Taxodium distichum	x	x	L			x	x		D
Beech, American	Fagus grandiflora	x	x	L				x		D
Birch, River	Betula nigra	x	x	L		x	x	x		D
Black Gum	Nyssa sylvatica	x	x	L				x		D
Cedar, Deodar	Cedrus deodara	x	x	L						E
Cedar, Eastern Red	Juniperus virginiana		x	L				x		E
Cryptomeria, Japanese	Cryptomeria japonica	x	x				x			E

Trees		City Tree Ordinance Approved	CIP/ROW Approved	City Zoning Approved (Large or Small Maturing)	Duke Transmission Zone(T) or Distribution line(D) Approved	Shade Tolerant	Tolerates Poor Drainage	Native	Blooming	Foliage (Deciduous, Semi-deciduous, or Evergreen)
Common Name	Scientific Name									
LARGE MATURING (50'+ H) cont...										
Dawn Redwood	<i>Metasequoia glyptostroboides</i>	x	x							S
Elm, Princeton	<i>Ulmus americana 'Princeton'</i>		x							D
Elm, Lacebark	<i>Ulmus parvifolia</i>	x	x	L		x	x			D
Ginkgo ‡	<i>Ginkgo biloba</i>	x	x	L		x	x			D
Hackberry, Common	<i>Celtis occidentalis</i>	x		L		x	x	x		D
Hackberry, Sugar	<i>Celtis laevigata</i>	x				x	x	x		D
Hemlock, Eastern	<i>Tsuga canadensis</i>			L		x		x		E
Hickory, Bitternut	<i>Carya cordiformis</i>			L				x		D
Hickory, Pignut	<i>Carya glabra</i>			L				x		E
Hickory, Shagbark	<i>Carya ovata</i>			L				x		E
Holly, American	<i>Ilex opaca</i>	x	x	S		x		x		E
Honeylocust, Shademaster**	<i>Gleditsia tricanthos inermis 'Shademaster'</i>							x		D
Hornbeam, European	<i>Carpinus betulus</i>	x	x	S		x	x			D
Kentucky Coffeetree	<i>Gymnocladus dioicus</i>	x	x			x		x		D
Linden, Little Leaf	<i>Tilia cordata</i>	x				x	x		x	D
Magnolia, Cucumber	<i>Magnolia acuminata</i>		x					x	x	D
Magnolia, Southern	<i>Magnolia grandiflora</i>	x	x	L			x	x	x	E
Maple, Freeman	<i>Acer x fremanii</i>	x	x			x		x		D
Maple, Red *	<i>Acer rubrum</i>		x	L		x	x	x		D
Maple, Sugar	<i>Acer saccharum</i>	x	x	L		x		x		D
Oak, Black	<i>Quercus velutina</i>			L		x		x		D
Oak, Fastigiante English	<i>Quercus robur 'Fastigiata'</i>		x							D

Trees		City Tree Ordinance Approved	CIP/ROW Approved	City Zoning Approved (Large or Small Maturing)	Duke Transmission Zone(T) or Distribution line(D) Approved	Shade Tolerant	Tolerates Poor Drainage	Native	Blooming	Foliage (Deciduous, Semi-deciduous, or Evergreen)
Common Name	Scientific Name									
LARGE MATURING (50'+ H) cont...										
Oak, Laurel	<i>Quercus laurifolia</i>	x		L		x		x		D
Oak, Live	<i>Quercus virginiana</i>	x	x	L		x	x	x		E
Oak, Northern Red*	<i>Quercus rubra</i>			L		x		x		D
Oak, Nuttall	<i>Quercus nuttallii</i>	x	x			x		x		D
Oak, Overcup	<i>Quercus lyrata</i>	x	x			x	x	x		D
Oak, Scarlet**	<i>Quercus coccinea</i>			L				x		D
Oak, Shumard	<i>Quercus shumardii</i>	x	x	L		x		x		D
Oak, Southern Red	<i>Quercus falcata</i>	x	x	L		x		x		D
Oak, Swamp White	<i>Quercus bicolor</i>		x	L		x	x	x		D
Oak, Water	<i>Quercus nigra</i>		x	L			x	x		D
Oak, White	<i>Quercus alba</i>		x	L		x		x		D
Oak, Willow	<i>Quercus phellos</i>	x	x	L		x	x	x		D
Pecan	<i>Carya illinoensis</i>			L				x		D
Persimmon	<i>Diospyros virginiana</i>			L		x		x		D
Pine, Austrian	<i>Pinus nigra</i>	x		L			x			E
Pine, Japanese Black	<i>Pinus thunbergi</i>			L						E
Pine, Loblolly	<i>Pinus taeda</i>	x	x	L			x	x		E
Pine, Shortleaf	<i>Pinus echinata</i>		x	L				x		E
Pine, Virginia	<i>Pinus virginiana</i>	x	x	L				x		E
Poplar, Tulip	<i>Liriodendron tulipifera</i>	x	x	L		x	x	x	x	D
Sweetgum, Fruitless	<i>Liquidambar styraciflua</i> 'Rotundiloba'	x	x	L		x	x	x		D
Sweetgum, Slender	<i>Liquidambar styraciflua</i> 'Slender Silhouette'		x			x	x	x		D
Zelkova, Japanese *	<i>Zelkova serrata</i>			L		x				D

Trees		City Tree Ordinance Approved	CIP/ROW Approved	City Zoning Approved (Large or Small Maturing)	Duke Transmission Zone(T) or Distribution line(D) Approved	Shade Tolerant	Tolerates Poor Drainage	Native	Blooming	Foliage (Deciduous, Semi-deciduous, or Evergreen)
Common Name	Scientific Name									
MEDIUM MATURING (30'-50'H)										
Arborvitae, American †	<i>Thuja occidentalis</i>		x		D		x	x		E
Carolina Silverbell	<i>Halesia carolina</i>	x	x	S		x		x	x	D
Chinese Pistache	<i>Pistacia chinensis</i>	x	x			x	x			D
Crape Myrtle (Biloxi, Natchez)*	<i>Lagerstroemia</i>		x							D
Dogwood, Flowering ‡	<i>Cornus florida</i>	x	x	S	D	x		x	x	D
Dogwood, Kousa ‡-	<i>Cornus kousa</i>	x	x	S	D	x		x	x	D
Fringetree, Chinese	<i>Chionanthus retusus</i>	x				x			x	D
Golden Raintree	<i>Koelreuteria paniculata</i>		x	S					x	D
Hawthorne, Green	<i>Crataegus viridis</i> 'Winter King'	x	x				x	x	x	D
Holly, 'Emily Brunner'	<i>Ilex X 'Emily Brunner'</i>		x			x				E
Holly, 'Nellie R. Stevens'	<i>Ilex X 'Nellie R. Stevens'</i>		x			x				E
Holly, Savannah	<i>Ilex X attenuata</i> 'Savannah'		x	S			x	x		E
Hornbeam, American	<i>Carpinus caroliniana</i>	x	x	S		x	x	x		D
Maple, Hedge	<i>Acer campestre</i>		x	S			x			D
Maple, Paperbark	<i>Acer griseum</i>		x							D
Maple, Trident	<i>Acer buergeranum</i>	x	x			x				D
Redbud, Chinese ‡	<i>Cercis chinensis</i>	x	x		D	x			x	D
Sourwood	<i>Oxydendrum arboreum</i>			S		x		x	x	D

Trees		City Tree Ordinance Approved	CIP/ROW Approved	City Zoning Approved (Large or Small Maturing)	Duke Transmission Zone(T) or Distribution line(D) Approved	Shade Tolerant	Tolerates Poor Drainage	Native	Blooming	Foliage (Deciduous, Semi-deciduous, or Evergreen)
Common Name	Scientific Name									
SMALL MATURING (UP-25'H)										
Arborvitae, Emerald Green	<i>Thuja occidentalis</i> 'Emerald Green'		x							E
Buckeye, Bottlebrush †	<i>Aesculus parviflora</i>	x	x		T	x		x	x	D
Camellia, Sasanuqa	<i>Camellia sasanqua</i>		x	S		x			x	E
Cherry, Kwanzan	<i>Prunus serrulata</i> 'Kwanzan'	x		S					x	D
Cherry, Snowgoose	<i>Prunus serrulata</i> 'Snowgoose'		x						x	D
Cherry, 'Okame'	<i>Prunus</i> X 'Okame'	x	x						x	D
Cherry, Weeping	<i>Prunus subhirtella pendula</i>			S					x	D
Cherry, Yoshino	<i>Prunus</i> X <i>yedoensis</i>	x	x	S	D				x	D
Cherrylaurel, Carolina	<i>Prunus caroliniana</i>			S		x	x	x	x	E
Crabapple, Japanese Flowering †	<i>Malus floribunda</i>		x	S	D				x	D
Crape Myrtle	<i>Lagerstroemia</i>		x							D
Dogwood, redbud †	<i>Cornus sericea</i> f. <i>baileyi</i>		x		D		x	x	x	D
Dogwood, Rutger's Hybrid	<i>Cornus kousa</i> X <i>florida</i>		x		D	x	x		x	D
Filbert, American	<i>Corylus americana</i>	x	x		T,D	x		x		D
Fringetree	<i>Chionanthus virginiana</i>		x				x	x	x	D
Hawthorne, Washington	<i>Crataegus phaenopyrum</i>	x	x	S			x	x	x	D
Holly, Foster	<i>Ilex</i> X <i>attenuata</i> 'Fosteri'	x	x	S			x	x		E
Holly, Yaupon	<i>Ilex vomitoria</i>		x	S		x		x		E
Magnolia, Star †	<i>Magnolia stellata</i>	x	x	S	D		x	x	x	D

Trees		City Tree Ordinance Approved	CIP/ROW Approved	City Zoning Approved (Large or Small Maturing)	Duke Transmission Zone(T) or Distribution line(D) Approved	Shade Tolerant	Tolerates Poor Drainage	Native	Blooming	Foliage (Deciduous, Semi-deciduous, or Evergreen)
Common Name	Scientific Name									
SMALL MATURING (UP-25'H)										
Magnolia, Lily Flowered	Magnolia liliiflora		x			x			x	D
Magnolia, 'Little Gem'	Magnolia grandiflora 'Little Gem'	x	x				x	x	x	E
Magnolia, 'Merrill'	Magnolia X loebneri 'Merrill'		x				x	x	x	D
Magnolia, Saucer	Magnolia X soulangiana	x	x	S	D		x	x	x	D
Maple, Armur 'Flame' †	Acer tataricum ginnala 'Flame'	x	x		D		x			D
Maple, Japanese	Acer palmatum	x	x			x				D
Maple, Purplebow/Shantung	Acer truncatum		x							D
Plum, Purpleleaf	Prunus cerasifera 'Atropurpurea'	x	x	S					x	D
Redbud, Eastern	Cercis canadensis	x	x	S	D	x	x	x	x	D
Serviceberry	Amelanchier arborea	x	x					x	x	D
Serviceberry, Shadbush †	Amelanchier canadensis	x	x	S	T	x		x	x	D
Waxmyrtle	Myrica cerifera	x		S			x			E

SHRUBS

Common Name	Scientific Name
Burford holly *	<i>Ilex cornuta burfordi</i>
Camellia *	<i>Camellia japonica</i>
Convex Japanese holly *	<i>Ilex crenata `convexa`</i>
Dwarf burford holly *	<i>Ilex cornuta burfordi nana</i>
Emily brunner holly *	<i>Ilex "Emily Brunner"</i>
English holly *	<i>Ilex aquifolium</i>
Evergreen euonymus *	<i>Euonymus japonicus</i>
Flowering quince	<i>Chaenomeles speciosa</i>
Forsythia	<i>Forsythia intermedia</i>
Glenn dale azalea *	<i>Azalea hybrida</i>
Glossy abelia *	<i>Abelia grandiflora</i>
Hetzi Japanese holly *	<i>Ilex crenata `hetzi`</i>
Hetzi jumper *	<i>Jumperus chinensis hetzi</i>
Indian azalea *	<i>Azalea indica</i>
Inkberry holly *	<i>Ilex glabra</i>
Japanese aucuba *	<i>Aucuba japonica</i>
Kaempferi azalea *	<i>Azalea obtusum Kaempferi</i>
Laurel *	<i>Laurus nobilis</i>
Loropetalum *	<i>Loropetalum chinense</i>
Lusterleaf holly *	<i>Ilex latifolia</i>
Oakleaf hydrangea	<i>Hydrangea quercifolia</i>
Perny holly *	<i>Ilex pernyi</i>
Pfitzer juniper *	<i>Juniperus chinensis pfitzeriana</i>

Common Name	Scientific Name
Roundleaf Japanese holly *	<i>Ilex crenata `rotundifolia`</i>
Sasanqua Camellia *	<i>Camellia sasanqua</i>
Witch-hazel	<i>Hammamelis virginiana</i>
Yaupon holly *	<i>Ilex vomitoria</i>
Wax myrtle *	<i>Myrica cerifera</i>
Wild olive *	<i>Osmanthus americana</i>
Chinese photinia *	<i>Photinia serrulata</i>
Mountain andromeda *	<i>Pieris floribunda</i>
Japanese andromeda *	<i>Pieris japonica</i>
Pittosporum *	<i>Pittosporum tobira</i>
English laurel *	<i>Prunus laurocerasus</i>
Podocarpus *	<i>Podocarpus macrophyllus maki</i>
Narrow leafed English laurel *	<i>Prunus laurocerasus angustifolia</i>
Scarlet firethorn	<i>Pyracantha coccinea</i>
Yeddo-hawthorn *	<i>Raphiolepis umbellata</i>
Reeves spirea	<i>Spirea cantoniensis</i>
Thunberg spirea	<i>Spirea thunbergii</i>
Bridalwreath spirea	<i>Spirea prunifolia plena</i>
Vanhoutte spirea	<i>Spirea vanhouttei</i>
Japanese yew *	<i>Taxus cuspidata</i>
Leatherleaf viburnum *	<i>Viburnum rhytidophyllum</i>
Laurestinus viburnum *	<i>Viburnum tinus</i>

* denotes evergreen

Other species may be allowed with staff approval

List subject to change

REFERENCES

1. North Carolina Department of Transportation, Standard Specifications for Roads and Structures, latest edition.
2. North Carolina Department of Transportation, Roadway Standards Drawings, latest edition.
3. City of Charlotte Department of Transportation, Work Area Traffic Control Handbook (WATCH), latest edition.
4. City of Charlotte and Mecklenburg County Storm Water Services, Charlotte-Mecklenburg Storm Water Design Manual, latest edition.
5. American Association of State Highway and Transportation Officials most recent edition, A Policy on Geometric Design of Highways and Streets.
6. North Carolina Department of Transportation, Roadway Design Manual, latest edition.
7. NCDEQ -Division of Energy, Mineral, and Land Resources, Erosion and Sediment Control Planning and Design Manual, latest edition.
8. NCDEQ, Storm Water Best Management Practices, latest edition.
9. Charlotte-Mecklenburg SCM Design Manual, latest edition.
10. City of Charlotte, CDOT Pavement Marking Standards, latest edition.
11. The City of Charlotte Urban Street Design Guidelines, adopted by City Council October 22, 2007.
12. Federal Highway Administration, Manual on Uniform Traffic Control Devices (MUTCD), latest edition.
13. United States Access Board, Public Right-of-Way Accessibility Guidelines (PROWAG), latest edition.
14. City of Charlotte, Charlotte Streets Manual
15. City of Charlotte, Post Installation Inspection and Repair of Storm Drainage Pipes and Culverts, latest edition.
16. Charlotte Storm Water Services, Third-Party Inspection for Pipe Installations, latest edition.

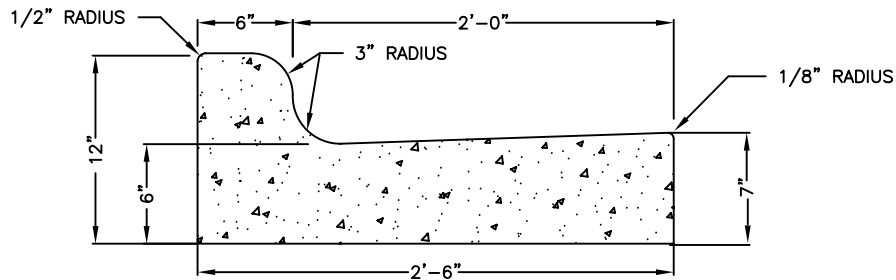

STANDARD 2'-6" CURB AND GUTTER

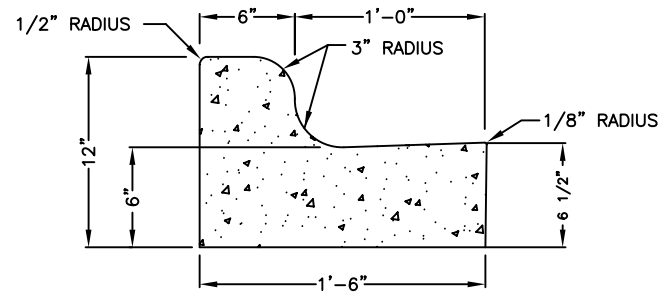

1'-6" STANDARD CURB AND GUTTER

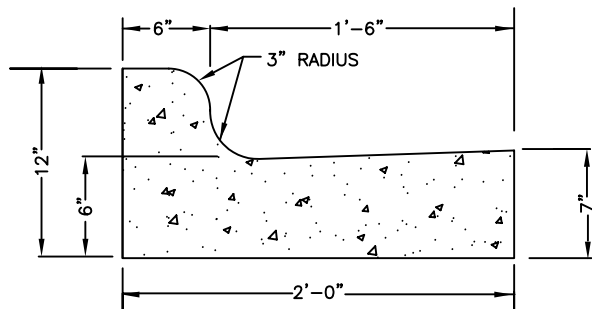

2'-0" STANDARD CURB & GUTTER

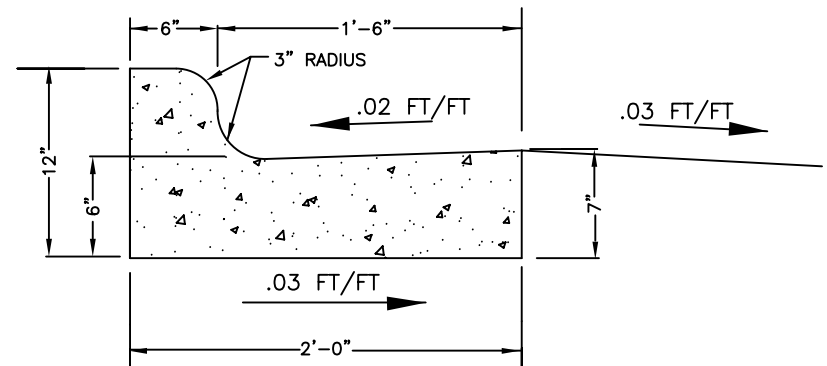

SLOPE FOR VARIABLE
SUPERELEVATION RATES

NOT TO SCALE



CITY OF CHARLOTTE
LAND DEVELOPMENT STANDARDS
INCLUDES CHARLOTTE ETJ

STANDARD CURB AND GUTTER

STD. NO.	REV.
10.17A	

2'-0" VALLEY GUTTER

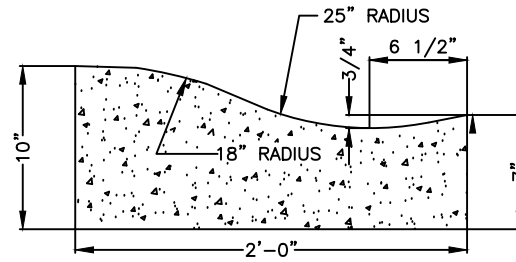

1'-6" MEDIAN CURB AND GUTTER**

TO BE USED IN MEDIANS WHEN LANES ARE SLOPED FROM ISLAND OR AS SPECIFIED BY THE APPROPRIATE CITY DEPT.

**ONLY FOR USE ON MEDIANS WITHIN CITY-MAINTAINED STREETS.

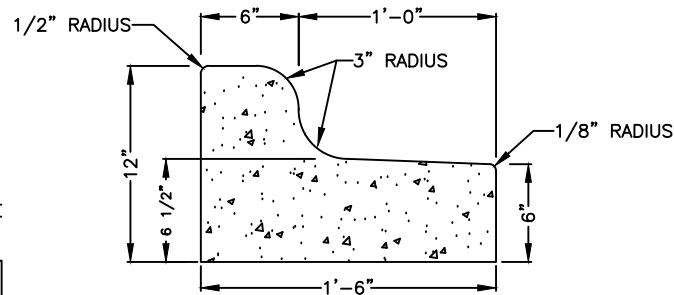

1'-6" MOUNTABLE CURB AND GUTTER

TO BE USED IN MEDIANS OR TRUCK APRONS ONLY; WHEN SPECIFIED BY THE APPROPRIATE CITY DEPT.

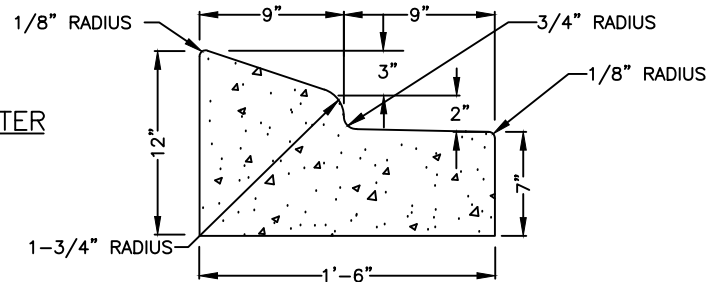

NOT TO SCALE



CITY OF CHARLOTTE
LAND DEVELOPMENT STANDARDS
INCLUDES CHARLOTTE ETJ

CURB AND GUTTER

STD. NO.	REV.
10.17B	20

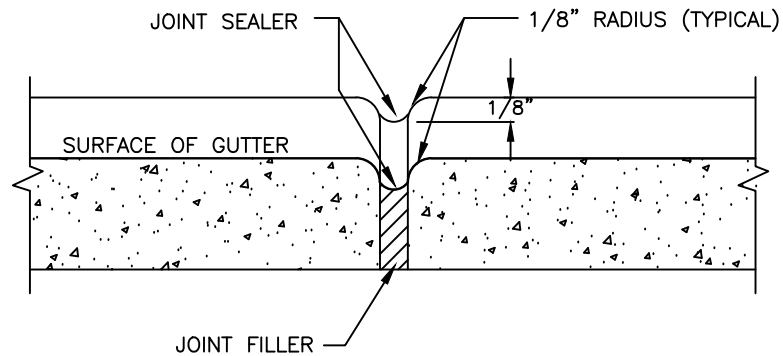

TRANSVERSE EXPANSION JOINT

NOTES:

1. CONTRACTION JOINTS SHALL BE SPACED AT 10-FOOT INTERVALS. FOR VALLEY GUTTER, A 10-FOOT SPACING MAY BE USED WHEN A MACHINE IS USED. JOINT SPACING MAY BE ALTERED BY THE CITY ENGINEER TO PREVENT UNCONTROLLED CRACKING.
2. CONTRACTION JOINTS MAY BE INSTALLED BY THE USE OF TEMPLATES OR FORMED BY OTHER APPROVED METHODS. WHERE SUCH JOINTS ARE NOT FORMED BY TEMPLATES, A MINIMUM DEPTH OF 1 1/2" SHALL BE OBTAINED.
3. ALL EXPANSION JOINTS SHALL BE SPACED AT 90-FOOT INTERVALS, AND ADJACENT TO ALL RIGID OBJECTS. JOINTS SHALL MATCH LOCATIONS WITH JOINTS IN ABUTTING SIDEWALK.
4. CONCRETE COMPRESSIVE STRENGTH SHALL BE 3600 P.S.I. IN 28 DAYS.
5. CURB SHALL BE DEPRESSED AT INTERSECTIONS TO PROVIDE FOR FUTURE ACCESSIBLE RAMPS.
6. TOP 6" OF SUBGRADE BENEATH THE CURB AND GUTTER SHALL BE COMPACTED TO 100% STANDARD PROCTOR DENSITY.
7. FOR CURB AND GUTTER INSTALLATIONS THE ETJ, NCDOT REQUIRES THAT ALL JOINTS MUST BE FILLED WITH JOINT SEALER PER NCDOT STANDARD SPECIFICATIONS FOR ROADS AND STRUCTURES, SECTION 846-3 (C).

NOT TO SCALE



CITY OF CHARLOTTE
LAND DEVELOPMENT STANDARDS
INCLUDES CHARLOTTE ETJ

CURB AND GUTTER

STD. NO.	REV.
10.17C	21

NOTES:

1. CONTRACTION JOINTS SHALL BE SPACED AT 10-FOOT INTERVALS. JOINT SPACING MAY BE ALTERED BY THE ENGINEER TO PREVENT UNCONTROLLED CRACKING.
2. CONTRACTION JOINTS MAY BE INSTALLED BY THE USE OF TEMPLATES OR FORMED BY OTHER APPROVED METHODS. WHERE SUCH JOINTS ARE NOT FORMED BY TEMPLATES, A MINIMUM DEPTH OF 1 1/2" SHALL BE OBTAINED.
3. ALL EXPANSION JOINTS SHALL BE SPACED AT 90-FOOT INTERVALS, AND ADJACENT TO ALL RIGID OBJECTS. JOINTS SHALL MATCH LOCATIONS WITH JOINTS IN ABUTTING SIDEWALK.
4. CONCRETE COMPRESSIVE STRENGTH SHALL BE 3600 P.S.I. IN 28 DAYS.
5. CURB SHALL BE DEPRESSED AT INTERSECTIONS TO PROVIDE FOR FUTURE ACCESSIBLE RAMPS.
6. TOP 6" OF SUBGRADE BENEATH THE CURB SHALL BE COMPACTED TO 100% STANDARD PROCTOR DENSITY.
7. DETAIL MAY BE USED FOR PRIVATE DRIVES, PARKING LOTS, AND INTERIOR CIRCULATION DRIVE.

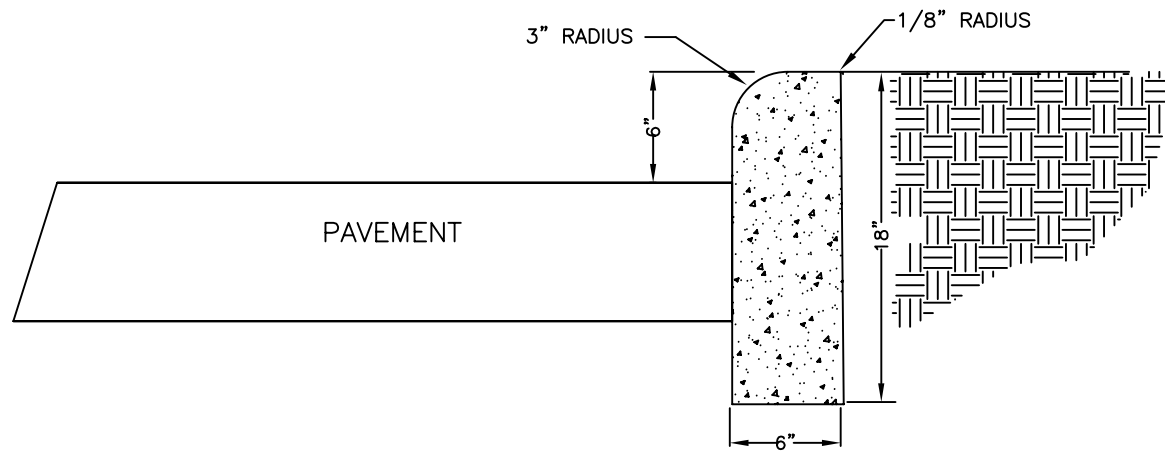

NOT TO SCALE



CITY OF CHARLOTTE
LAND DEVELOPMENT STANDARDS
INCLUDES CHARLOTTE ETJ

18" VERTICAL CURB

STD. NO.	REV.
10.18	

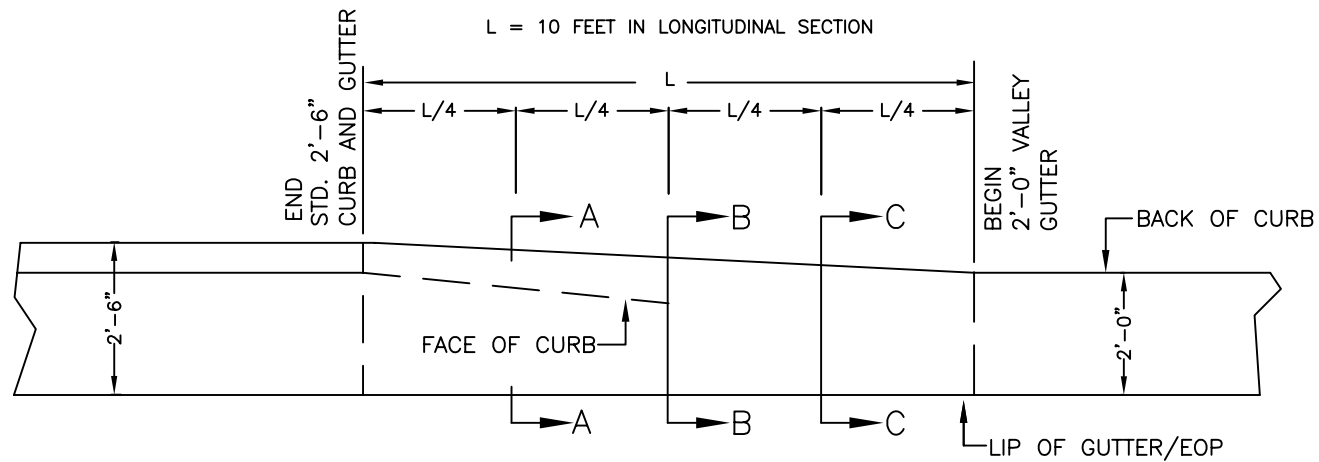

PLAN VIEW

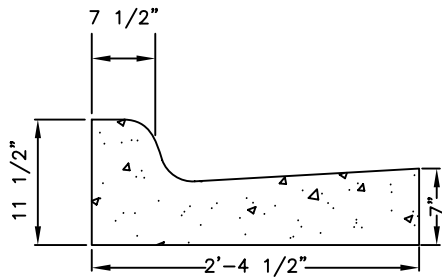

SECTION A-A

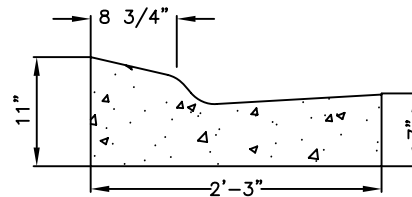

SECTION B-B

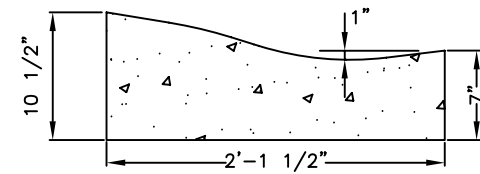

SECTION C-C

NOTES:

1. TRANSITION IS NOT TO BE LOCATED WITHIN THE CURB RADIUS.

NOT TO SCALE



CITY OF CHARLOTTE
LAND DEVELOPMENT STANDARDS
INCLUDES CHARLOTTE ETJ

CURB TRANSITION
2'-6" CURB AND GUTTER TO 2'-0" VALLEY GUTTER

STD. NO.	REV.
10.19	

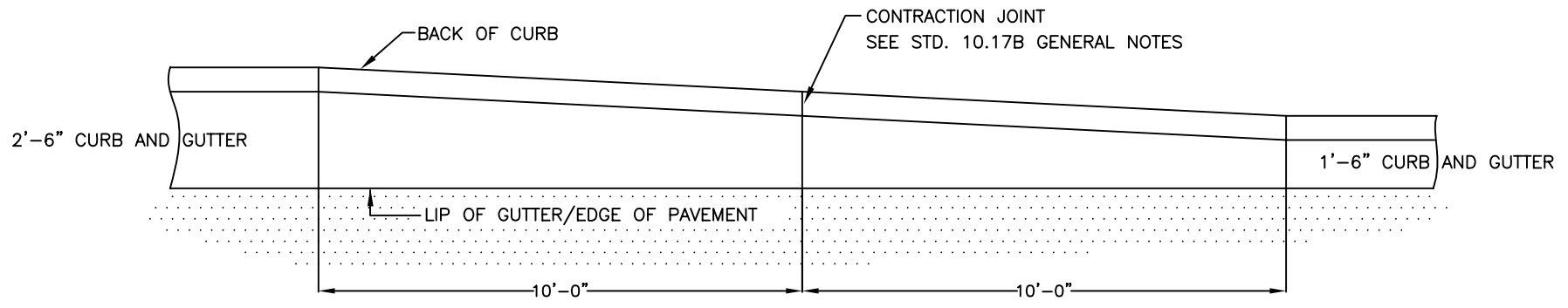

PLAN VIEW

NOTES:

1. TRANSITION TO BE ALONG BACK OF CURB.

NOT TO SCALE



CITY OF CHARLOTTE
 LAND DEVELOPMENT STANDARDS
 INCLUDES CHARLOTTE ETJ

CURB TRANSITION
 2'-6" CURB AND GUTTER TO
 1'-6" CURB AND GUTTER

STD. NO.	REV.
10.20	

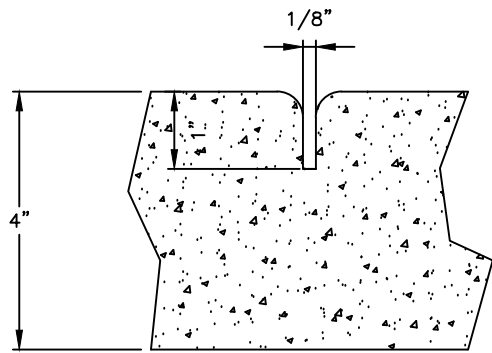

GROOVE JOINT IN SIDEWALK

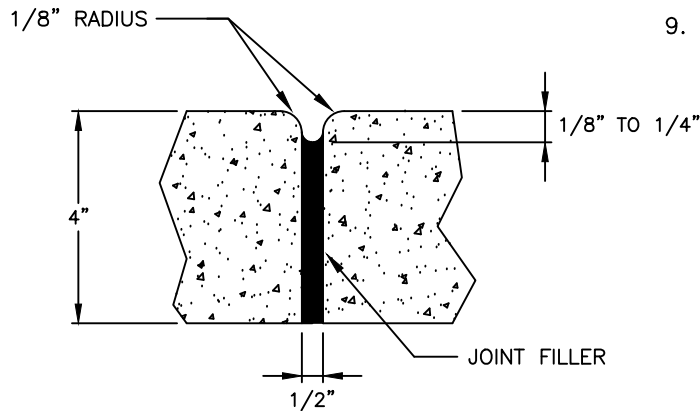

TRANSVERSE EXPANSION JOINT IN SIDEWALK

GENERAL NOTES:

1. A GROOVE JOINT 1" DEEP WITH 1/8" RADII SHALL BE REQUIRED IN THE CONCRETE SIDEWALK WITH JOINT SPACING EQUAL TO THE WIDTH OF SIDEWALK, UP TO 10' WIDTH. WIDER THAN 10' REQUIRES SPECIAL DESIGN (SEE DETAIL #10.42 FOR MULTI-USE PATH).
2. ONE 1/2" EXPANSION JOINT WILL BE REQUIRED AT INTERVALS OF NOT MORE THAN 45' AND MATCHING EXPANSION/CONSTRUCTION JOINT IN ADJACENT CURB. A SEALED 1/2" EXPANSION JOINT WILL BE REQUIRED WHERE THE SIDEWALK JOINS ANY RIGID STRUCTURE.
3. SIDEWALK AT DRIVEWAY ENTRANCES TO BE 6" THICK.
4. WIDTH OF SIDEWALK ON ARTERIALS SHALL BE BASED ON THE STREETS MAP TYPICAL SECTION. WIDTH OF SIDEWALKS ON UPTOWN STREETS WILL BE BASED ON TABLE 33-6 OF THE UDO.
5. WIDTH OF SIDEWALKS ON NON-ARTERIALS SHALL BE BASED ON TYPICAL SECTION, OR AS SHOWN ON THE STREETS MAP WHEN A SHARED USE PATH IS SHOWN. SIDEWALK/SUP OF REQUIRED WIDTH TO BE POURED TO END OF RADIUS AT INTERSECTING STREETS.
6. CONCRETE COMPRESSIVE STRENGTH SHALL BE 3600 PSI. IN 28 DAYS.
7. ZONING CONDITIONS MAY REQUIRE ADDITIONAL WIDTH SIDEWALKS WHICH SHALL SUPERSEDE THESE STANDARD DIMENSIONS SHOWN.
8. LIDS FOR JUNCTION BOXES AND UTILITY VAULTS SHALL BE NON-SKID AS SPECIFIED BY ENGINEER.
9. JOINT MATERIALS SHALL LIMIT SHRINK/SWELL SO POST CONSTRUCTION INSTALLATION RESULTS IN A MAXIMUM OF 1/4" FROM FLUSH.

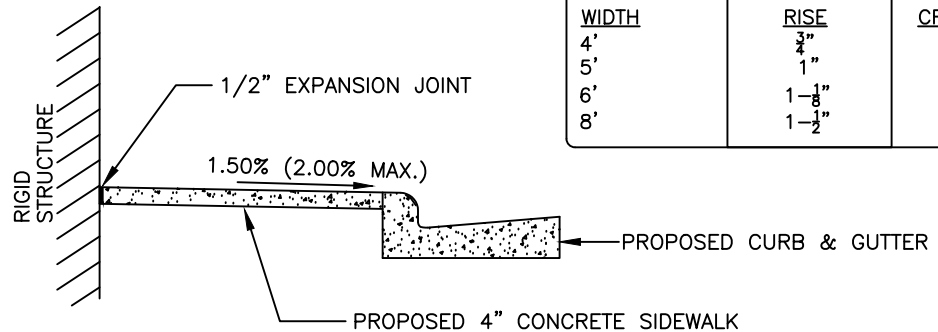

DETAILS SHOWING EXPANSION JOINTS IN CONCRETE SIDEWALK

EXAMPLE SIDEWALK CONSTRUCTION DIMENSIONS:		
WIDTH	RISE	CROSS-SLOPE
4'	3/4"	1.56%
5'	1"	1.67%
6'	1-1/8"	1.56%
8'	1-1/2"	1.56%

NOT TO SCALE



CITY OF CHARLOTTE
LAND DEVELOPMENT STANDARDS
INCLUDES CHARLOTTE ETJ

CONCRETE SIDEWALKS

STD. NO.	REV.
10.22	23

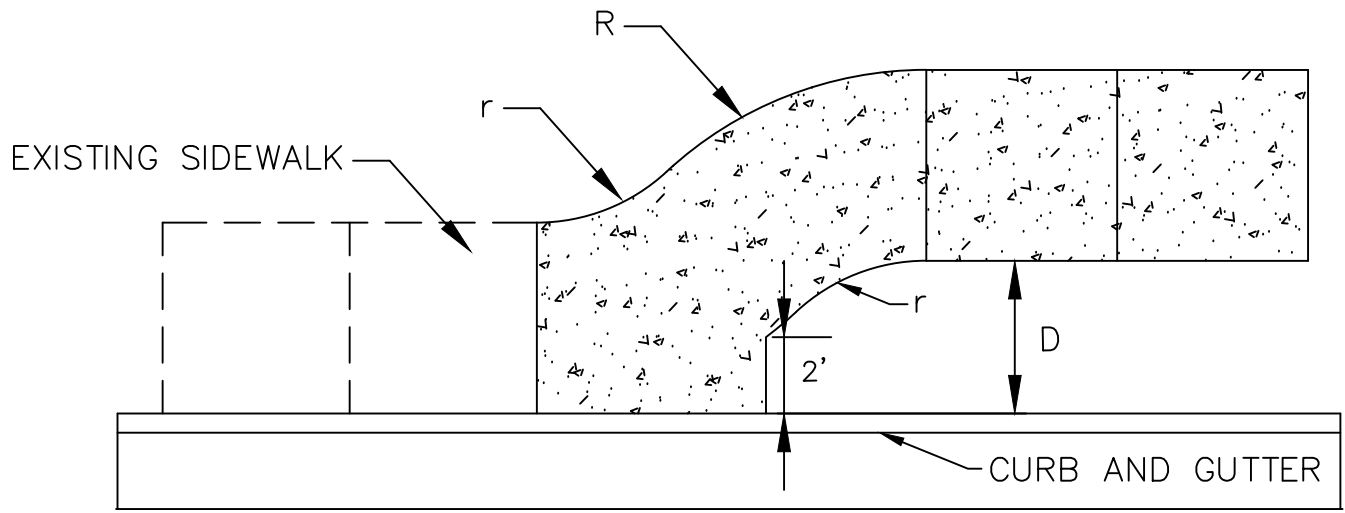

SIDEWALK TRANSITION DETAIL AT BACK OF CURB
Not to scale

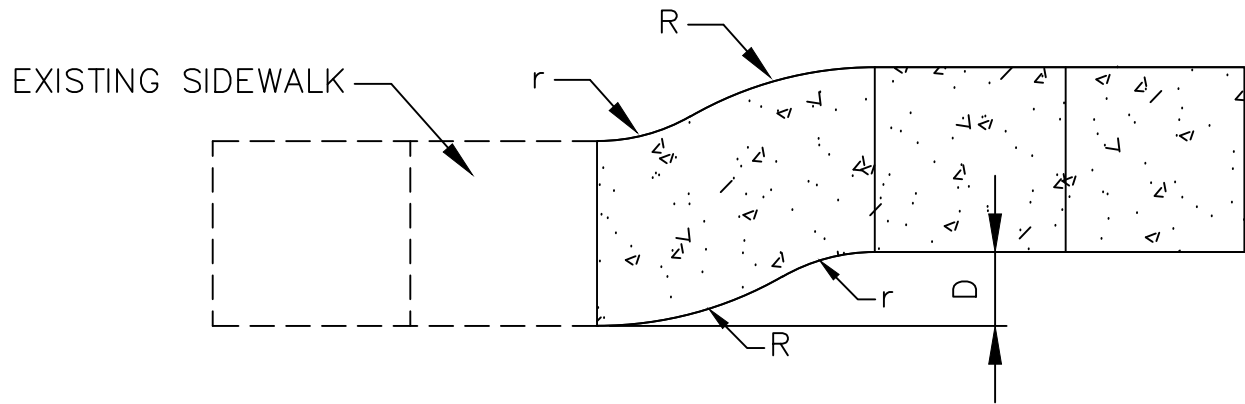

SIDEWALK TRANSITION DETAIL (PLANTING STRIP BOTH SIDES)
Not to scale

KEY

D	R	r
0' - 2.9'	10'	4'
3' - 7.9'	25'	19'
8' +	50'	44'



CITY OF CHARLOTTE
LAND DEVELOPMENT STANDARDS
INCLUDES CHARLOTTE ETJ

SIDEWALK TRANSITION

STD. NO.	REV.
10.23	18

NOTES:

1. 1/2" EXPANSION JOINTS REQUIRE INSTALLATION OF ONE 1/2" THICK PIECE OF BITUMINOUS FIBER THROUGH THE ENTIRE SLAB. JOINT MATERIAL SHOULD BE PLACED FLUSH WITH CONCRETE.
2. TO LIMIT STORM WATER FLOW DOWN DRIVEWAYS, USE STANDARD 10.24C FOR DRIVEWAYS NEAR LOW POINTS.
3. ALL DRIVEWAYS MUST MEET THE CURRENT CITY DRIVEWAY REGULATIONS AND NCDOT REQUIREMENTS FOR SPACING, SIGHT DISTANCE AND OFFSETS FROM PROPERTY LINES AND INTERSECTIONS.
4. "A" BREAKOVER SHALL BE 8% OR LESS (A = ALGEBRAIC DIFFERENCE).
5. PRIOR APPROVAL IS REQUIRED BY CDOT ON GRADES EXCEEDING WHAT ARE SHOWN.
6. ** PER NC IFC SECTION D103.2, FIRE APPARATUS ACCESS ROADS SHALL NOT EXCEED 10 PERCENT IN GRADE.
7. REFER TO CHAPTER 32 OF THE UDO FOR MODIFICATIONS RELATED TO TREE PRESERVATION OR CONSTRAINED SPACES.
10. DRIVEWAY APRON MUST BE ASPHALT OR CONCRETE EXTENDED FROM EXISTING ROADWAY EDGE OF PAVEMENT TO THE RIGHT-OF-WAY LINE, OR BACK OF SIDEWALK, WHICHEVER IS GREATER.

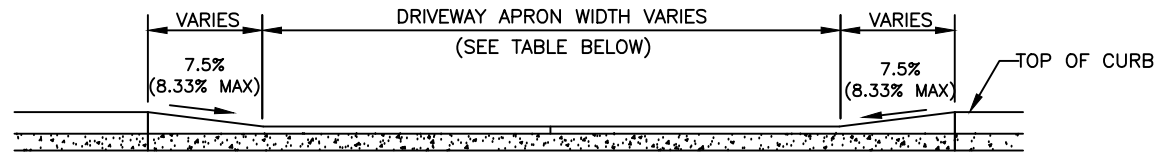

SECTION A - A

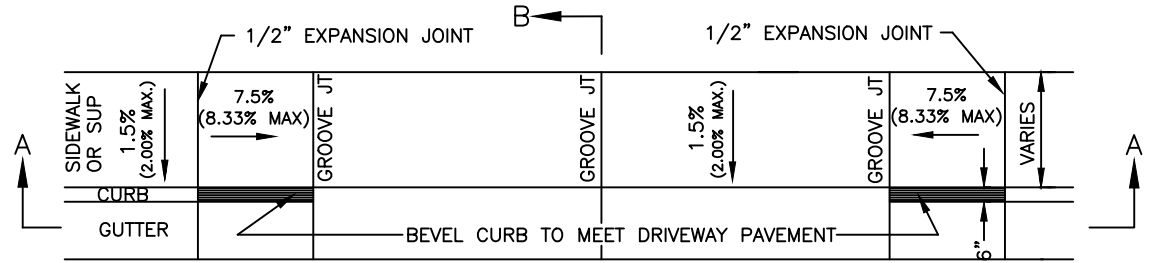

PLAN

GENERAL NOTES:

- ALL CONCRETE TO BE 3600 P.S.I. COMPRESSIVE STRENGTH.
- ALL CURB, CURB AND GUTTER AND SIDEWALKS ARE TO BE REMOVED TO THE NEAREST JOINT BEYOND NEW CONSTRUCTION OR CUT WITH A SAW AND REMOVED.
- SAW CUT OR JOINT TO BE PERPENDICULAR TO EDGE OF EXISTING PAVEMENT.
- SEE STD. NO 10.17B FOR DETAIL OF EXPANSION JOINT AND GROOVE JOINT.

DRIVEWAY APRON WIDTH		
TYPE DRIVEWAY	MINIMUM	MAXIMUM
TYPE I-RESIDENTIAL: LOCAL/COLLECTOR ARTERIAL *	10' 15'	24' 24'
ONE-WAY TYPE II COMMERCIAL	20'	30'
TWO-WAY TYPE II COMMERCIAL	26'	50'

* MUST PROVIDE ON-SITE TURNAROUND

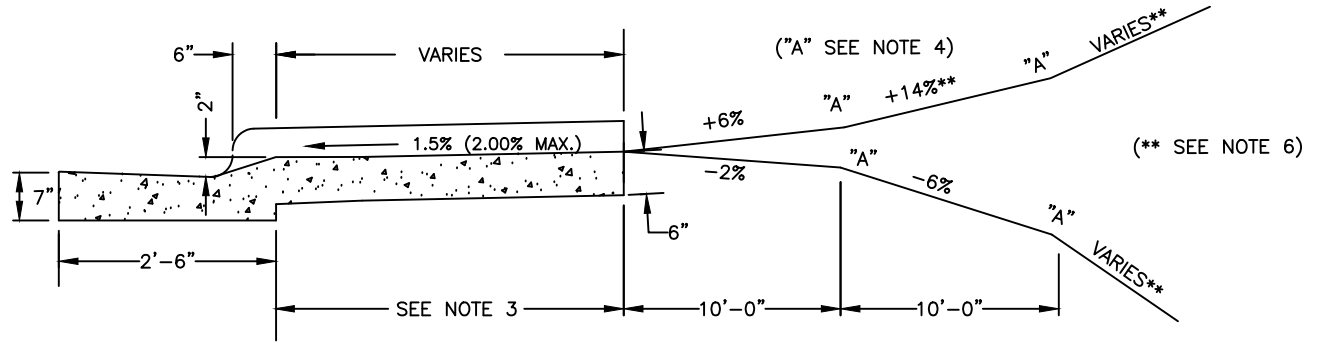

SECTION B - B

NOT TO SCALE



CITY OF CHARLOTTE
LAND DEVELOPMENT STANDARDS
INCLUDES CHARLOTTE ETJ

COMMERCIAL TYPE II AND RESIDENTIAL TYPE I
DROP CURB DRIVEWAY WITH SIDEWALK ABUTTING
CURB (2'-6" CURB AND GUTTER)

STD. NO.	REV.
10.24A	25

NOTE:

1. 1/2" EXPANSION JOINTS REQUIRE INSTALLATION OF ONE 1/2" THICK PIECE OF BITUMINOUS FIBER THROUGH THE ENTIRE SLAB. JOINT MATERIAL SHOULD BE PLACED FLUSH WITH CONCRETE.
2. TO LIMIT STORM WATER FLOW DOWN DRIVEWAYS, USE STANDARD 10.24C FOR DRIVEWAYS NEAR LOW POINTS.
3. ALL DRIVEWAYS MUST MEET THE CURRENT CITY DRIVEWAY REGULATIONS AND NCDOT REQUIREMENTS FOR SPACING, SIGHT DISTANCE AND OFFSETS FROM PROPERTY LINES AND INTERSECTIONS.
4. "A" BREAKOVER SHALL BE 8% OR LESS (A = ALGEBRAIC DIFFERENCE).
5. PRIOR APPROVAL IS REQUIRED BY CDOT ON GRADES EXCEEDING WHAT ARE SHOWN.
6. ** PER NC IFC SECTION D103.2, FIRE APPARATUS ACCESS ROADS SHALL NOT EXCEED 10 PERCENT IN GRADE.
7. REFER TO CHAPTER 32 OF THE UDO FOR MODIFICATIONS RELATED TO TREE PRESERVATION OR CONSTRAINED SPACES.
10. DRIVEWAY APRON MUST BE ASPHALT OR CONCRETE EXTENDED FROM EXISTING ROADWAY EDGE OF PAVEMENT TO THE RIGHT-OF-WAY LINE, OR BACK OF SIDEWALK, WHICHEVER IS GREATER.

GENERAL NOTES:

- ALL CONCRETE TO BE 3600 P.S.I. COMPRESSIVE STRENGTH.
- ALL CURB, CURB AND GUTTER AND SIDEWALKS ARE TO BE REMOVED TO THE NEAREST JOINT BEYOND NEW CONSTRUCTION OR CUT WITH A SAW AND REMOVED.
- SAW CUT OR JOINT TO BE PERPENDICULAR TO EDGE OF EXISTING PAVEMENT.
- SEE STD. NO 10.17B FOR DETAIL OF EXPANSION JOINT AND GROOVE JOINT.

DRIVEWAY APRON WIDTH		
TYPE DRIVEWAY	MINIMUM	MAXIMUM
TYPE I-RESIDENTIAL LOCAL/COLLECTOR ARTERIAL *	10'	24'
ONE-WAY TYPE II COMMERCIAL	20'	30'
TWO-WAY TYPE II COMMERCIAL	26'	50'

* MUST PROVIDE ON-SITE TURNAROUND

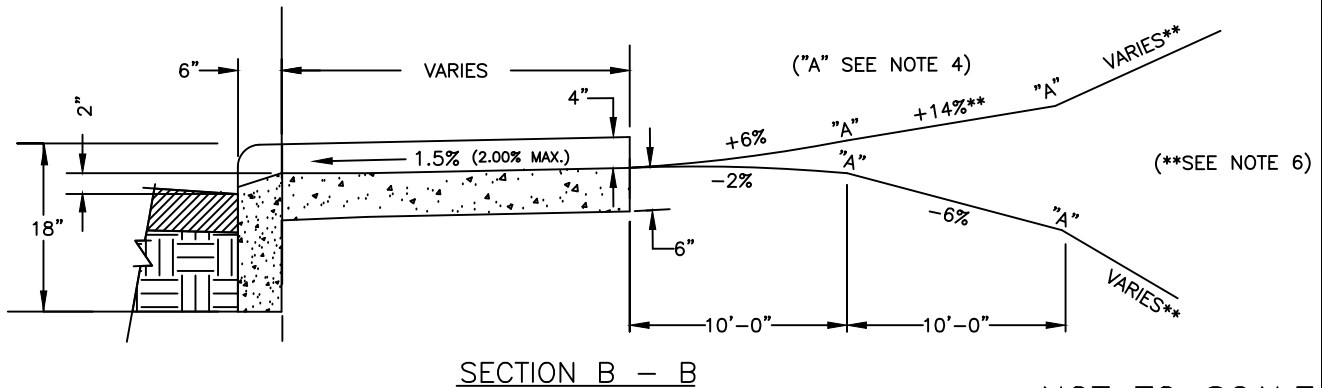
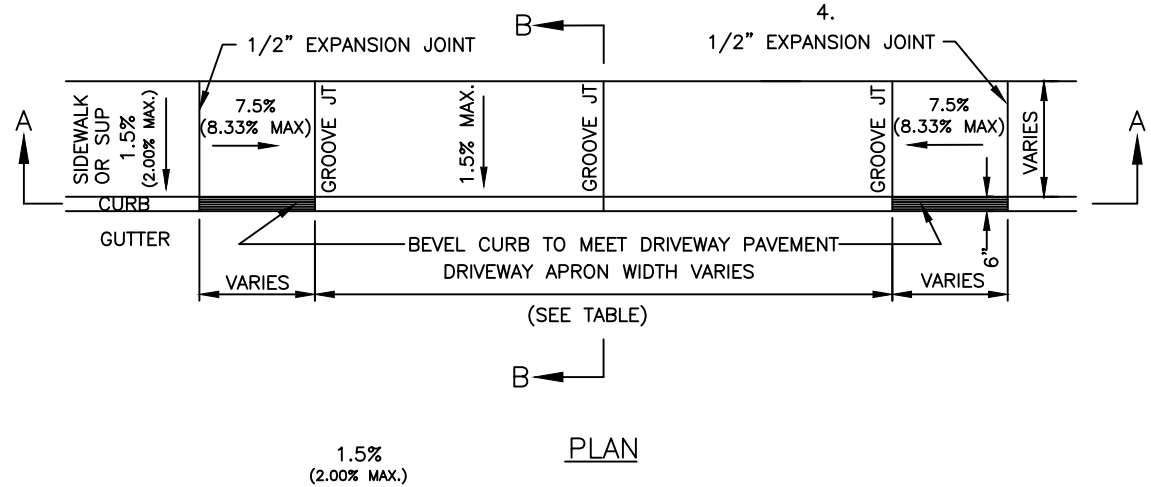
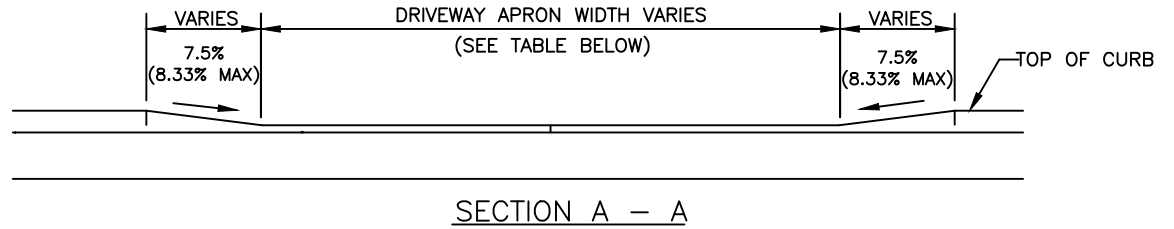

NOT TO SCALE



CITY OF CHARLOTTE
LAND DEVELOPMENT STANDARDS
INCLUDES CHARLOTTE ETJ

COMMERCIAL TYPE II AND RESIDENTIAL TYPE I DROP CURB
DRIVEWAY WITH SIDEWALK ABUTTING CURB
(6" X 18" VERTICAL CURB)

STD. NO.	REV.
10.24B	25

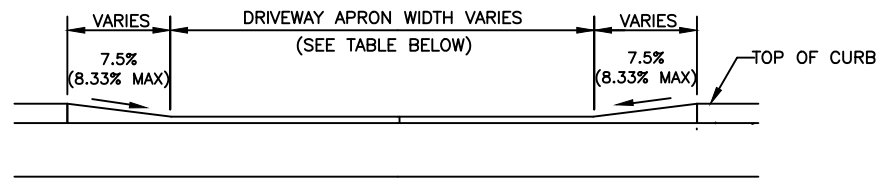
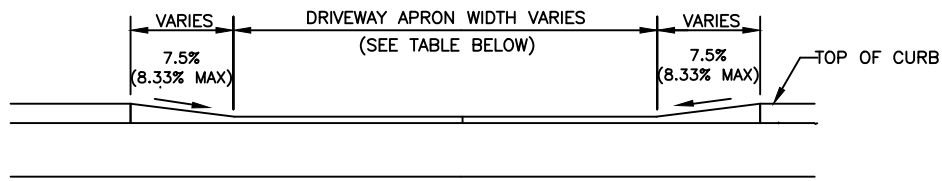

SECTION A - A

SECTION A - A

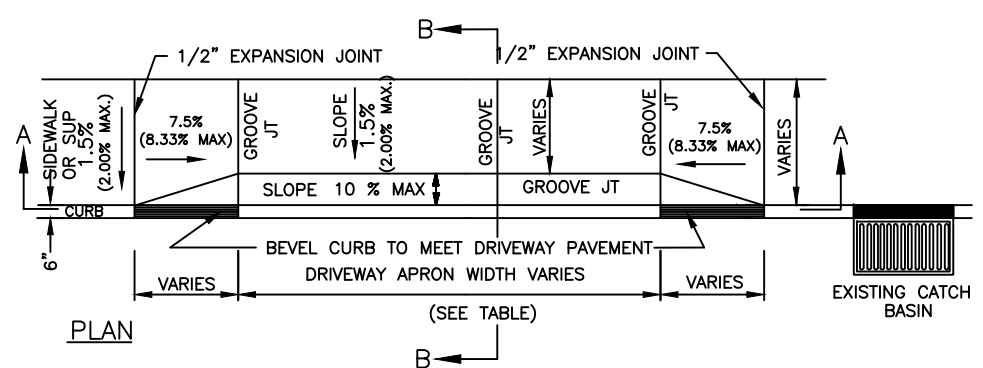
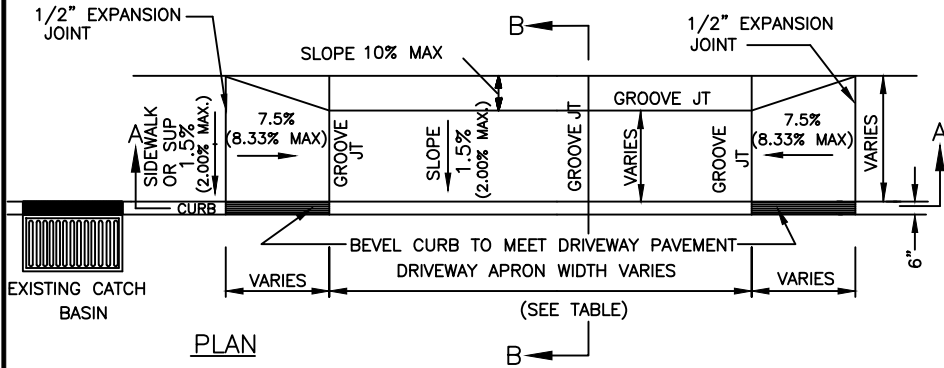

PLAN

PLAN

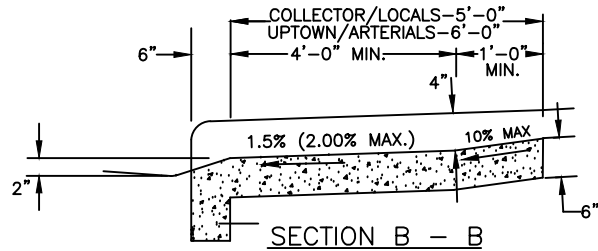

SECTION B - B

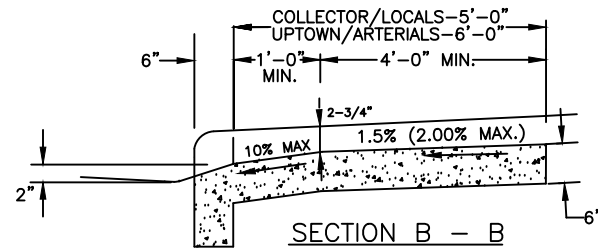

SECTION B - B

DRIVEWAY APRON WIDTH		
TYPE DRIVEWAY	MINIMUM	MAXIMUM
TYPE I-RESIDENTIAL: LOCAL/COLLECTOR	10'	24'
	ARTERIAL *	15'
ONE-WAY TYPE II COMMERCIAL	20'	30'
TWO-WAY TYPE II COMMERCIAL	26'	50'

* MUST PROVIDE ON-SITE TURNAROUND

NOTES

1. USED AT LOW POINTS IN ROADWAYS WITH 2'-6" CURB AND GUTTER OR 6" X 18" CURB AS DIRECTED BY THE CITY.
2. SEE STANDARDS 10.24A & 10.24B FOR ADDITIONAL DETAILS.
3. ALL DRIVEWAYS MUST MEET THE CURRENT CITY DRIVEWAY REGULATIONS AND NCDOT REQUIREMENTS FOR SPACING, SIGHT DISTANCE AND OFFSETS FROM PROPERTY LINES AND INTERSECTIONS.
4. JOINT MATERIAL SHOULD BE PLACED FLUSH WITH CONCRETE.
10. DRIVEWAY APRON MUST BE ASPHALT OR CONCRETE EXTENDED FROM EXISTING ROADWAY EDGE OF PAVEMENT TO THE RIGHT-OF-WAY LINE, OR BACK OF SIDEWALK, WHICHEVER IS GREATER.

NOT TO SCALE



CITY OF CHARLOTTE
LAND DEVELOPMENT STANDARDS
INCLUDES CHARLOTTE ETJ

COMMERCIAL TYPE II AND RESIDENTIAL TYPE I DROP CURB
DRIVEWAY WITH SIDEWALK ABUTTING CURB
6" X 18" (VERTICAL CURB)

STD. NO.	REV.
10.24C	25

NOTES:

1. ALL CONCRETE TO BE 3600 P.S.I.
2. ALL CURB OR CURB AND GUTTER AND SIDEWALKS ARE TO BE REMOVED TO THE NEAREST JOINT BEYOND NEW CONSTRUCTION OR CUT WITH A SAW AND REMOVED. SAW CUT OR JOINT TO BE PERPENDICULAR TO EDGE OF EXISTING PAVEMENT. SEE STD. NO. 10.17 FOR JOINT DETAIL.
3. ALL DRIVEWAYS MUST MEET THE CURRENT CITY DRIVEWAY REGULATIONS AND NCDOT REQUIREMENTS FOR SPACING, SIGHT DISTANCE AND OFFSETS FROM PROPERTY LINES AND INTERSECTIONS.
4. "A" BREAKOVER SHALL BE 8% OR LESS. (A = ALGEBRAIC DIFFERENCE).
5. PRIOR APPROVAL IS REQUIRED BY CDOT ON GRADES EXCEEDING WHAT ARE SHOWN.
6. ** PER NC IFC SECTION D103.2, FIRE APPARATUS ACCESS ROADS SHALL NOT EXCEED 10 PERCENT IN GRADE.
7. JOINT MATERIAL SHOULD BE PLACED FLUSH WITH CONCRETE.
8. DRIVEWAY APRON MUST BE ASPHALT OR CONCRETE EXTENDED FROM EXISTING ROADWAY EDGE OF PAVEMENT TO THE RIGHT-OF-WAY LINE, OR BACK OF SIDEWALK, WHICHEVER IS GREATER.

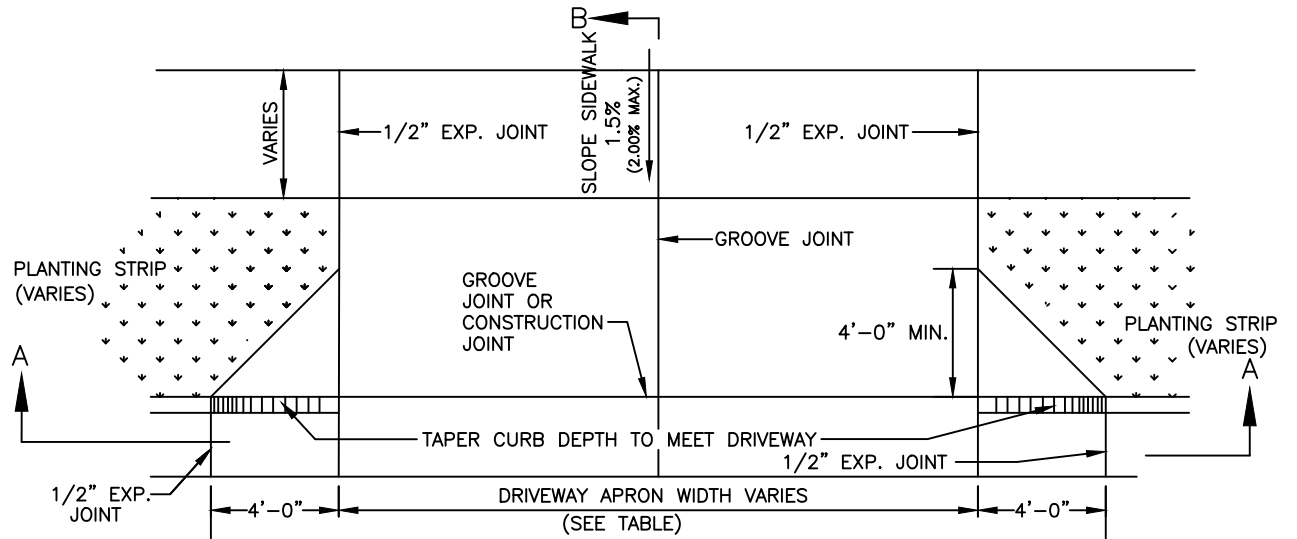

PLAN VIEW

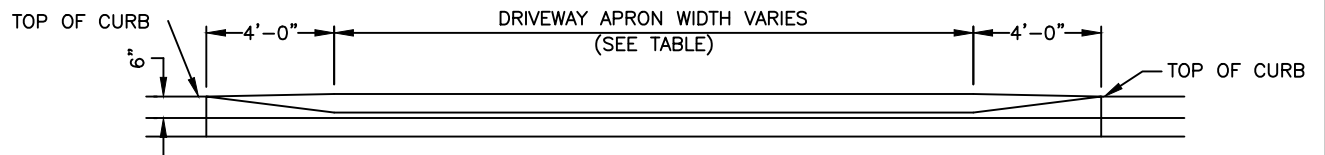

SECTION A - A

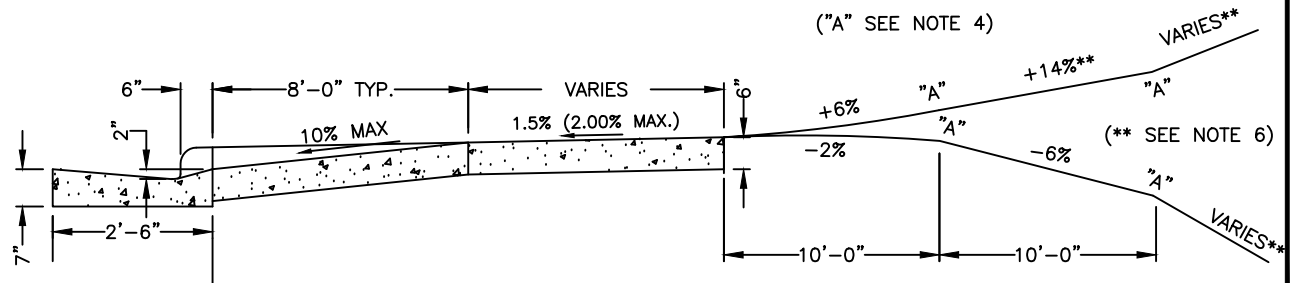

SECTION B - B

NOT TO SCALE

DRIVEWAY APRON WIDTH		
DRIVEWAY TYPE	MINIMUM	MAXIMUM
LOCAL/COLLECTOR	10'	24'
ARTERIAL *	15'	24'

* MUST PROVIDE ON-SITE TURNAROUND



CITY OF CHARLOTTE
LAND DEVELOPMENT STANDARDS
 INCLUDES CHARLOTTE ETJ

RESIDENTIAL DROP CURB TYPE I
 DRIVEWAY WITH PLANTING STRIP
 (2'-6" CURB AND GUTTER)

STD. NO.	REV.
10.25A	25

NOTES:

1. ALL CONCRETE TO BE 3600 P.S.I. COMPRESSIVE STRENGTH.
2. AT ALL DRIVEWAYS, SIDEWALKS TO BE REMOVED TO THE NEAREST JOINT BEYOND NEW CONSTRUCTION OR CUT WITH A SAW AND REMOVED. SAW CUT OR JOINT TO BE PERPENDICULAR TO EDGE OF EXISTING PAVEMENT. SEE STD. NO. 10.17 FOR JOINT DETAIL.
3. ALL DRIVEWAYS MUST MEET THE CURRENT CITY DRIVEWAY REGULATIONS AND NCDOT REQUIREMENTS FOR SPACING, SIGHT DISTANCE, AND OFFSETS FROM PROPERTY LINES AND INTERSECTIONS.
4. "A" BREAKOVER SHALL BE 8% OR LESS (A=ALGEBRAIC DIFFERENCE).
5. PRIOR APPROVAL IS REQUIRED BY CDOT ON GRADES EXCEEDING THE GRADES SHOWN ON THIS DETAIL.
6. **PER NC IFC SECTION D103.2, FIRE APPARATUS ROADS SHALL NOT EXCEED 10 PERCENT IN GRADE.
7. JOINT MATERIAL SHOULD BE PLACED FLUSH WITH CONCRETE.
8. THIS DETAIL IS ONLY FOR USE WHEN PLANTING STRIP IS 6' OR LESS IN WIDTH. USE TYPE II-MODIFIED DRIVEWAY 10.25E WITH LARGER PLANTING STRIP.
10. DRIVEWAY APRON MUST BE ASPHALT OR CONCRETE EXTENDED FROM EXISTING ROADWAY EDGE OF PAVEMENT TO THE RIGHT-OF-WAY LINE, OR BACK OF SIDEWALK, WHICHEVER IS GREATER.

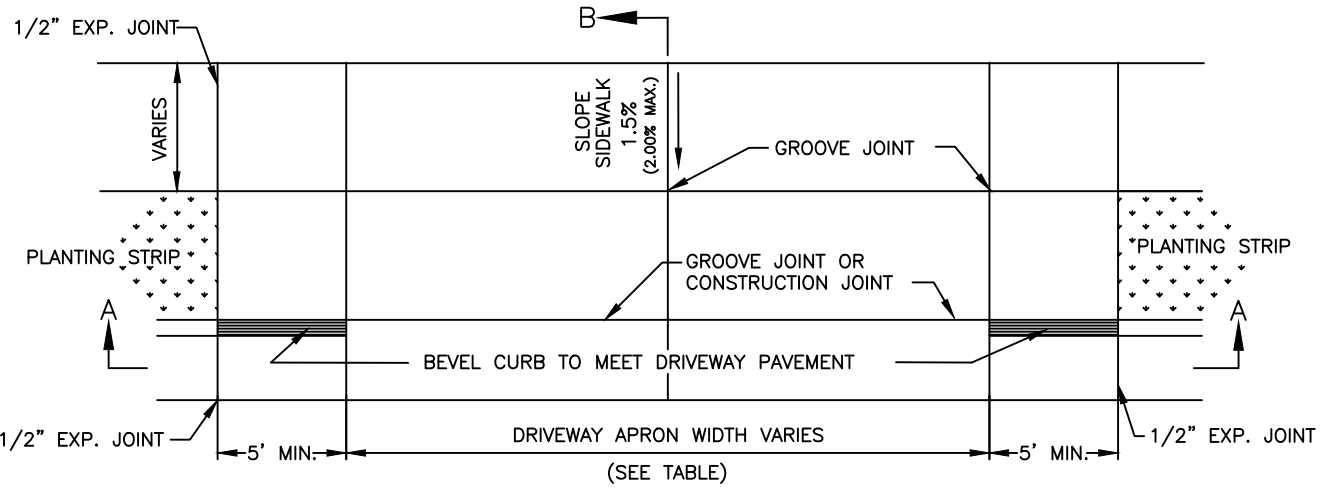

PLAN VIEW

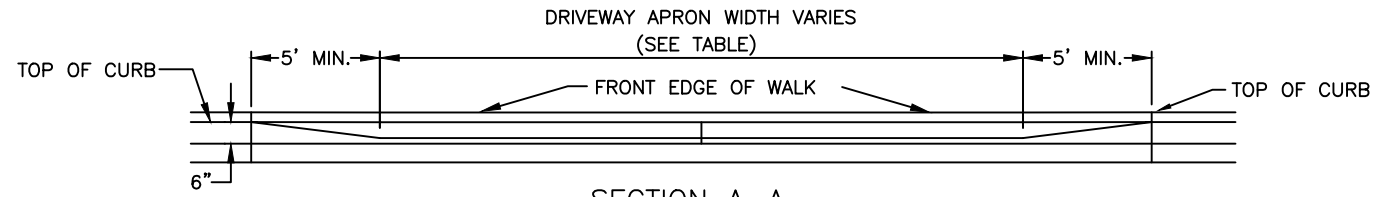

SECTION A-A

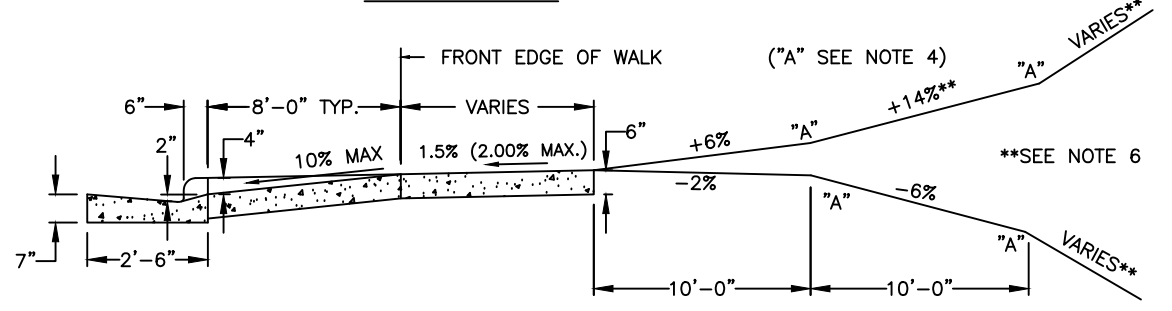

SECTION B-B

NOT TO SCALE

DRIVEWAY APRON WIDTH		
TYPE DRIVEWAYS	MINIMUM	MAXIMUM
ONE-WAY TYPE II - COMMERCIAL	20'	30'
TWO-WAY TYPE II - COMMERCIAL	26'	50'*

* NEED MORE THAN ONE CONTRACTION JOINT IN CENTER.



CITY OF CHARLOTTE
LAND DEVELOPMENT STANDARDS
 INCLUDES CHARLOTTE ETJ

COMMERCIAL DROP CURB TYPE II DRIVEWAY
WITH PLANTING STRIP
(2'-6" CURB AND GUTTER)

STD. NO.	REV.
10.25B	25

NOTES:

1. ALL CONCRETE TO BE 3600 P.S.I.
2. ALL CURB OR CURB AND GUTTER AND SIDEWALK ARE TO BE REMOVED TO THE NEAREST JOINT BEYOND NEW CONSTRUCTION OR CUT WITH A SAW AND REMOVED. SAW CUT OR JOINT TO BE PERPENDICULAR TO EDGE OF EXISTING PAVEMENT. SEE STD. NO. 10.17 FOR JOINT DETAIL.
3. ALL DRIVEWAYS MUST MEET THE CURRENT CITY DRIVEWAY REGULATIONS AND NCDOT REQUIREMENTS FOR SPACING, SIGHT DISTANCE, AND OFFSETS FROM PROPERTY LINES AND INTERSECTIONS.
4. "A" BREAKOVER SHALL BE 8% OR LESS.
5. PRIOR APPROVAL IS REQUIRED BY CDOT ON GRADES EXCEEDING WHAT ARE SHOWN.
6. ** PER NC IFC SECTION D103.2, FIRE APPARATUS ACCESS ROADS SHALL NOT EXCEED 10 PERCENT IN GRADE.
7. JOINT MATERIAL SHOULD BE PLACED FLUSH WITH CONCRETE.
8. DRIVEWAY APRON MUST BE ASPHALT OR CONCRETE EXTENDED FROM EXISTING ROADWAY EDGE OF PAVEMENT TO THE RIGHT-OF-WAY LINE, OR BACK OF SIDEWALK, WHICHEVER IS GREATER.

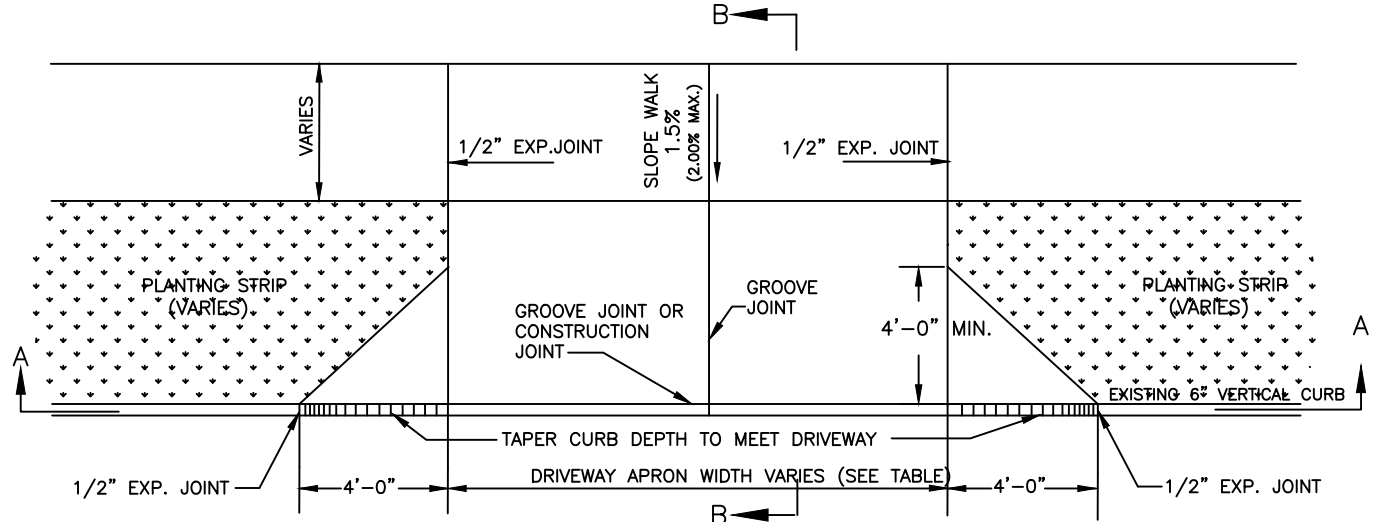

PLAN VIEW

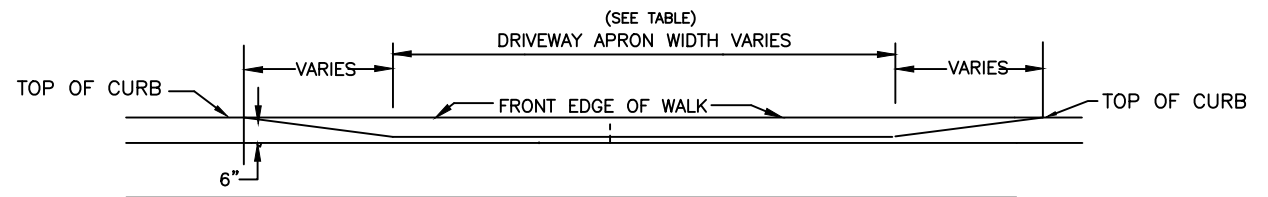

SECTION A-A (ALONG FLOW LINE)

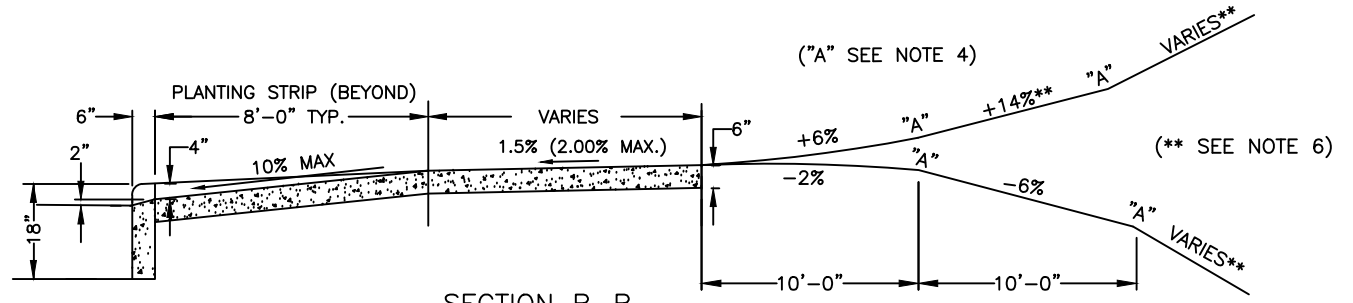

SECTION B-B

NOT TO SCALE

DRIVEWAY APRON WIDTH		
DRIVEWAY TYPE	MINIMUM	MAXIMUM
LOCAL/COLLECTOR	10'	24'
ARTERIAL *	15'	24'

* MUST PROVIDE ON-SITE TURNAROUND



CITY OF CHARLOTTE
LAND DEVELOPMENT STANDARDS
 INCLUDES CHARLOTTE ETJ

RESIDENTIAL DROP CURB TYPE I DRIVEWAY WITH PLANTING STRIP (6" X 18" VERTICAL CURB)

STD. NO.	REV.
10.25C	25

NOTES:

1. ALL CONCRETE TO BE 3600 P.S.I.
2. ALL CURB OR CURB AND GUTTER AND SIDEWALK ARE TO BE REMOVED TO THE NEAREST JOINT BEYOND NEW CONSTRUCTION OR CUT WITH A SAW AND REMOVED. SAW CUT OR JOINT TO BE PERPENDICULAR TO EDGE OF EXISTING PAVEMENT. SEE STD. NO. 10.17 FOR JOINT DETAIL.
3. ALL DRIVEWAYS MUST MEET THE CURRENT CITY DRIVEWAY REGULATIONS AND NCDOT REQUIREMENTS FOR SPACING, SIGHT DISTANCE, AND OFFSETS FROM PROPERTY LINES AND INTERSECTIONS.
4. "A" BREAKOVER SHALL BE 8% OR LESS. (A=ALGEBRAIC DIFFERENCE)
5. PRIOR APPROVAL IS REQUIRED BY CDOT FOR GRADES EXCEEDING THE GRADES SHOWN ON THIS DETAIL
6. **PER NC IFC SECTION D103.2, FIRE APPARATUS ACCESS ROADS SHALL NOT EXCEED 10 PERCENT IN GRADE.
7. JOINT MATERIAL SHOULD BE FLUSH WITH CONCRETE.
8. THIS DETAIL IS ONLY FOR USE WHEN PLANTING STRIP IS 6' OR LESS IN WIDTH. USE TYPE II-MODIFIED DRIVEWAY 10.25E WITH LARGER PLANTING STRIP.
8. DRIVEWAY APRON MUST BE ASPHALT OR CONCRETE EXTENDED FROM EXISTING ROADWAY EDGE OF PAVEMENT TO THE RIGHT-OF-WAY LINE, OR BACK OF SIDEWALK, WHICHEVER IS GREATER.

DRIVEWAY APRON WIDTH		
TYPE DRIVEWAYS	MINIMUM	MAXIMUM
ONE-WAY TYPE II-COMMERCIAL	20'	30'
TWO-WAY TYPE II-COMMERCIAL	26'	50'*

* NEED MORE THAN ONE CONTRACTION JOINT IN CENTER

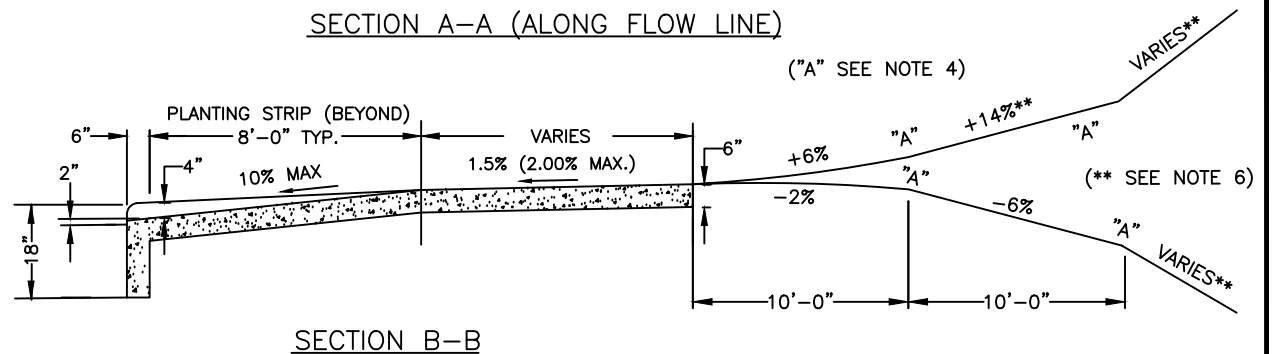
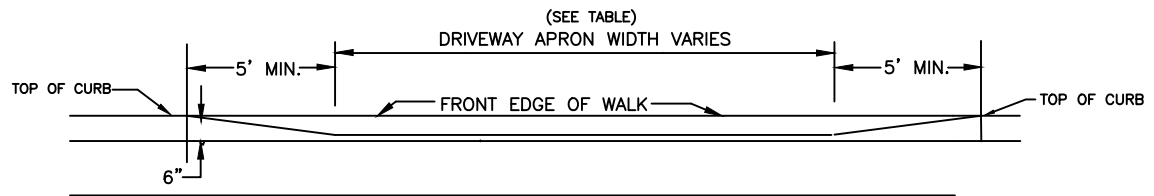
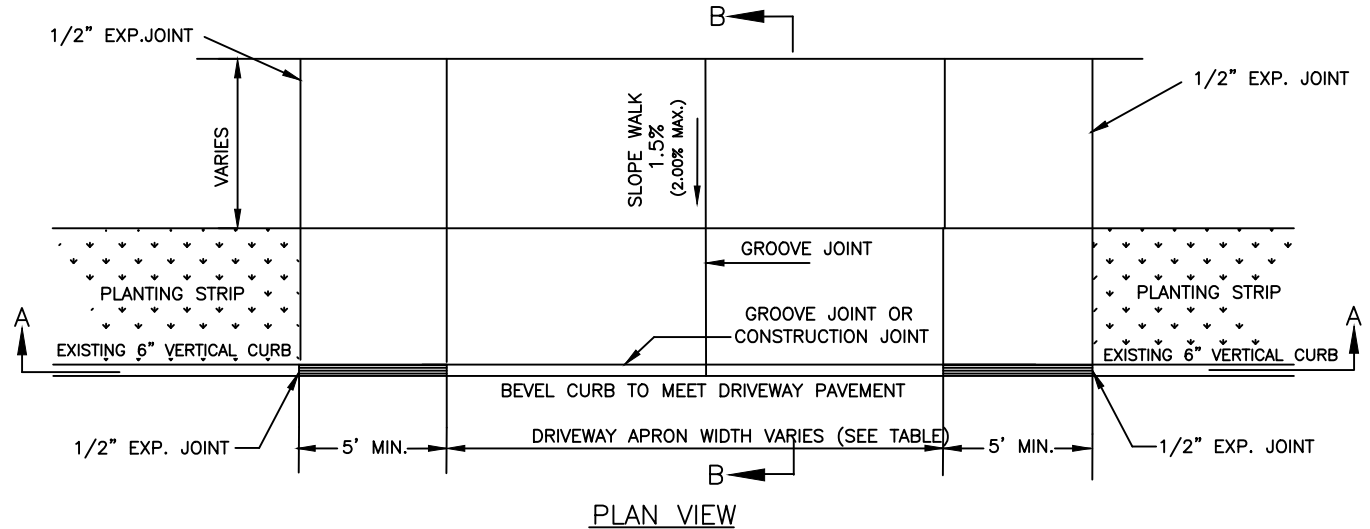

NOT TO SCALE



CITY OF CHARLOTTE
LAND DEVELOPMENT STANDARDS
 INCLUDES CHARLOTTE ETJ

COMMERCIAL DROP CURB TYPE II DRIVEWAY WITH
 PLANTING STRIP (6" X 18" VERTICAL CURB)

STD. NO.	REV.
10.25D	25

NOTES:

1. ALL CONCRETE TO BE 3600 P.S.I. COMPRESSIVE STRENGTH.
2. AT ALL DRIVEWAYS, SIDEWALKS TO BE REMOVED TO THE NEAREST JOINT BEYOND NEW CONSTRUCTION OR CUT WITH A SAW AND REMOVED. SAW CUT OR JOINT TO BE PERPENDICULAR TO EDGE OF EXISTING PAVEMENT. SEE CLDSM STD. #10.17 FOR JOINT DETAIL. PAY LIMITS FOR WORK DONE UNDER CITY OF CHARLOTTE CONTRACTS ARE FROM EXPANSION JOINT TO EXPANSION JOINT, FROM LIP OF CURB TO BACK OF SIDEWALK.
3. ALL DRIVEWAYS MUST MEET THE CURRENT CITY DRIVEWAY REGULATIONS AND NCDOT REQUIREMENTS FOR SPACING, SIGHT DISTANCE, AND OFFSETS FROM PROPERTY LINES AND INTERSECTIONS.
4. ALGEBRAIC DIFFERENCE IN GRADE ("A") BETWEEN SLOPES SHALL BE 8% OR LESS.
5. RADII MUST BE MINIMUM 8 FEET OR THE WIDTH OF THE PLANTING STRIP, WHICHEVER IS GREATER. RADII GREATER THAN THESE MINIMUMS MAY BE REQUIRED BY CDOT ON A CASE-BY-CASE BASIS. FOR RADII GREATER THAN 8 FEET, THE RADII ARE TO CONTINUE AS A BAND AT-GRADE THROUGH THE SIDEWALK.
6. PER NC IFC SECTION D103.2, FIRE APPARATUS ACCESS ROADS SHALL NOT EXCEED 10 PERCENT IN GRADE.
7. PAVERS USED IN DRIVEWAY MUST HAVE A THICKNESS OF 3 INCHES.
8. JOINT MATERIAL SHOULD BE PLACED FLUSH WITH CONCRETE.
9. THE DRIVEWAY MUST RISE 6" FROM THE GUTTER LINE TO PREVENT RUNOFF FROM ENTERING DRIVEWAY.
10. FOR STREETS WITH 2'-0" VALLEY GUTTER, PROVIDE TRANSITION ON EACH SIDE OF DRIVEWAY APRON FROM VALLEY GUTTER TO 2'-6" STANDARD CURB AND GUTTER USING CLDSM STD. DETAIL #10.19.
11. DRIVEWAY APRON MUST BE ASPHALT OR CONCRETE EXTENDED FROM EXISTING ROADWAY EDGE OF PAVEMENT TO THE RIGHT-OF-WAY LINE, OR BACK OF SIDEWALK, WHICHEVER IS GREATER.

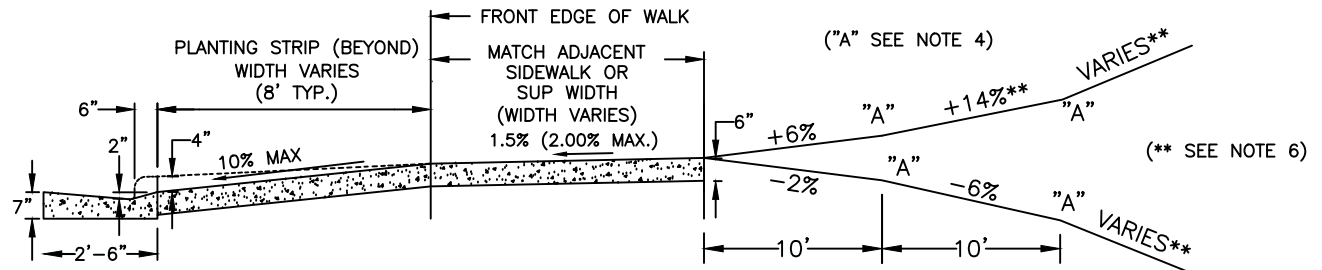
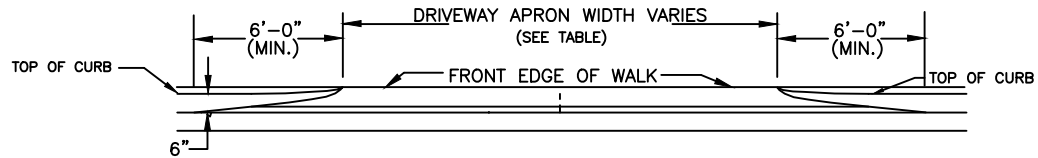
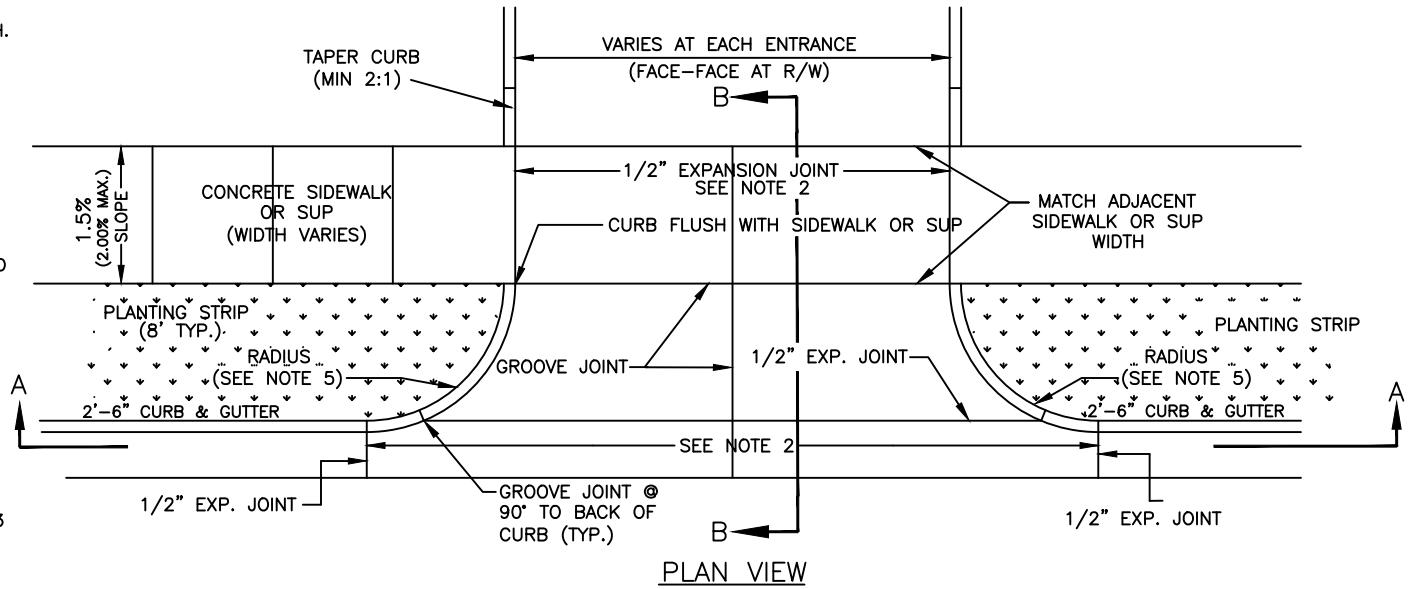

DRIVEWAY APRON DIMENSIONS		
OPERATION/RADIUS	MINIMUM	MAXIMUM
ONE-WAY WITH 6-12 FT. RADII	20'	30'
ONE-WAY WITH 13+ FT. RADII	15'	25'
TWO-WAY WITH 6-12 FT. RADII	26'	50'
TWO-WAY WITH 13+ FT. RADII	22'	40'

NOT TO SCALE



**CITY OF CHARLOTTE
LAND DEVELOPMENT STANDARDS**
INCLUDES CHARLOTTE ETJ

**TYPE II-MODIFIED DRIVEWAY DETAIL WITH
WIDE PLANTING STRIP AND STANDARD CURB**

STD. NO.	REV.
10.25E	25

NOTES:

1. TO BE USED ON ROADS WITHOUT CURB AND GUTTER AND WHERE CURB AND GUTTER IS NOT BEING INSTALLED. (MUST MEET BOTH CRITERIA)
2. ALL CONCRETE TO BE 3600 P.S.I. COMPRESSIVE STRENGTH.
3. THIS STANDARD IS TYPICALLY FOR COMMERCIAL APPLICATION – IT IS AN OPTION FOR RESIDENTIAL DRIVEWAY CONSTRUCTION.
4. "A" BREAKOVER SHALL BE 8% OR LESS.
5. ALL CONCRETE TO BE 3600 P.S.I.
6. ** PER NC IFC SECTION D103.2, FIRE APPARATUS ACCESS ROADS SHALL NOT EXCEED 10 PERCENT IN GRADE.
7. ALL DRIVEWAYS MUST MEET THE CURRENT CITY DRIVEWAY REGULATIONS AND NCDOT REQUIREMENTS FOR SPACING, SIGHT DISTANCE, AND OFFSETS FROM PROPERTY LINES AND INTERSECTIONS.
8. PRIOR APPROVAL IS REQUIRED BY CDOT ON GRADES EXCEEDING WHAT ARE SHOWN.
9. JOINT MATERIAL SHOULD BE PLACED FLUSH WITH CONCRETE.
10. DRIVEWAY APRON MUST BE ASPHALT OR CONCRETE EXTENDED FROM EXISTING ROADWAY EDGE OF PAVEMENT TO THE RIGHT-OF-WAY LINE, OR BACK OF SIDEWALK, WHICHEVER IS GREATER.

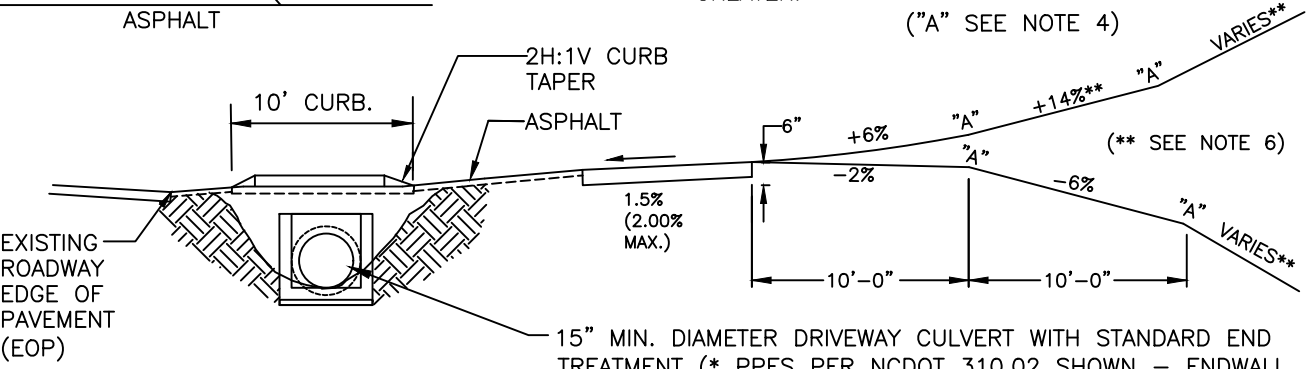
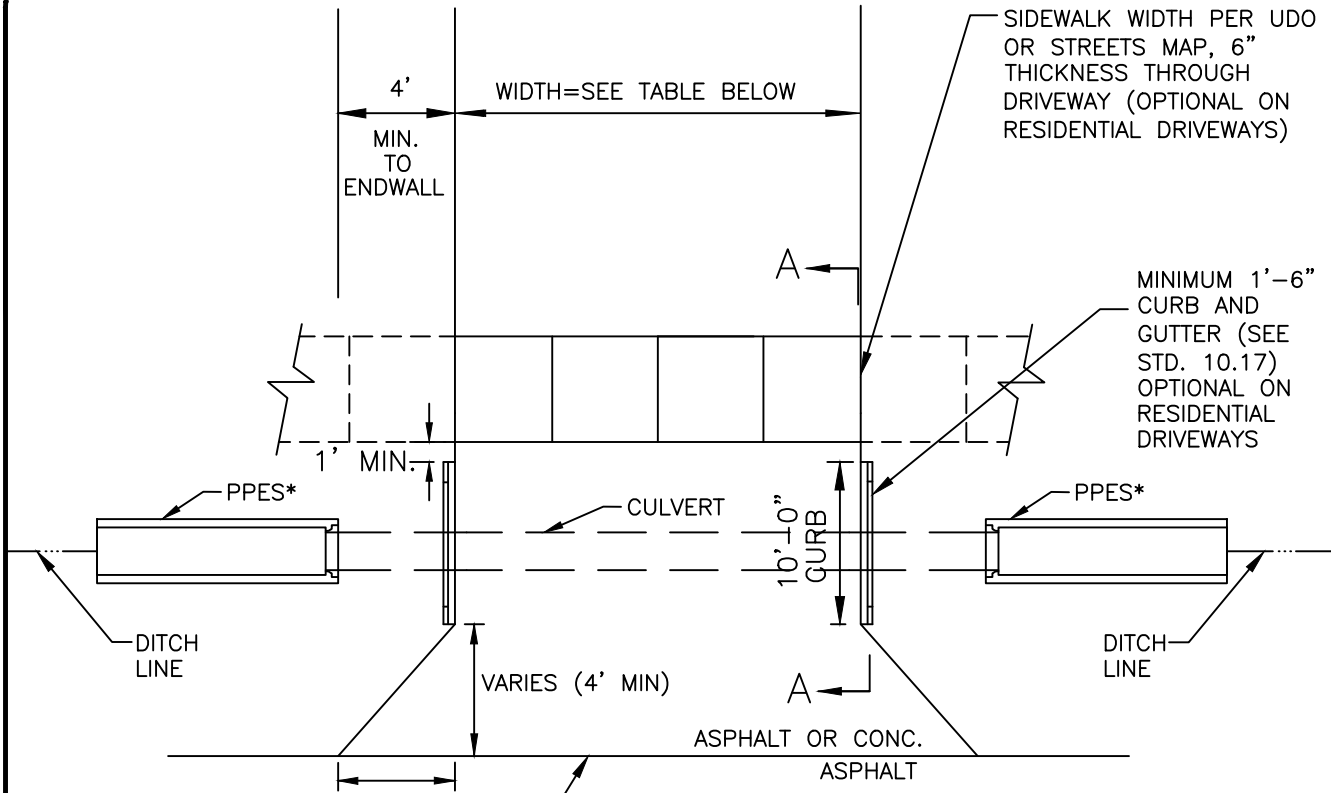

DRIVEWAY APRON WIDTH		
DRIVEWAY TYPE	MINIMUM	MAXIMUM
RESIDENTIAL:		
LOCAL/COLLECTOR	10'	24'
ARTERIAL *	15'	24'
ONE-WAY COMMERCIAL	20'	30'
TWO-WAY COMMERCIAL	26'	50'

* MUST PROVIDE ON-SITE TURNAROUND

SECTION A-A

NCDOT TO APPROVE FOR USE ON NCDOT SYSTEM ROAD



CITY OF CHARLOTTE
LAND DEVELOPMENT STANDARDS
 INCLUDES CHARLOTTE ETJ

TYPE IV DRIVEWAY

NOT TO SCALE

STD. NO.	REV.
10.25F	25

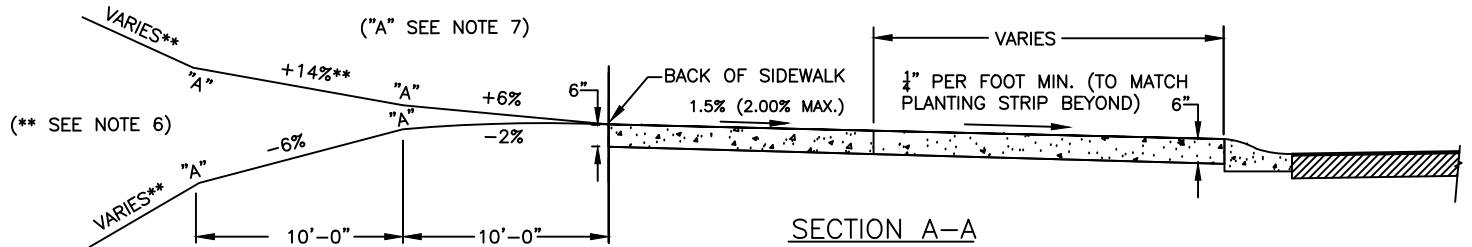

NOTES:

1. THE ELEVATION OF THE SIDEWALK SHALL BE NOT LESS THAN SIX INCHES OR MORE THAN EIGHTEEN INCHES ABOVE THE ROADWAY CROWN. THIS ELEVATION DIFFERENTIAL SHALL BE CONSISTENT WITHIN EACH BLOCK.
2. ALL CONCRETE TO BE 3600 PSI STRENGTH.
3. ALL CONSTRUCTION PRACTICES, INCLUDING COMPACTION, CURING, FINISHING, ETC. SHALL BE IN ACCORDANCE WITH THE CHARLOTTE LAND DEVELOPMENT STANDARDS.
4. PLANTING STRIP SHALL BE GRADED WITH A CROSS SLOPE BETWEEN 1/4 IN. PER FOOT AND 1 1/4 IN. PER FOOT EXCEPT WHERE EXCESSIVE NATURAL GRADES MAKE THIS REQUIREMENT IMPRACTICAL. IN SUCH CASES, THE CITY ENGINEER MAY AUTHORIZE A SUITABLE GRADE
5. ALL DRIVEWAYS MUST MEET THE CURRENT CITY DRIVEWAY REGULATIONS AND NCDOT REQUIREMENTS, INCLUDING BUT NOT LIMITED TO SPACING, SIGHT DISTANCE, AND OFFSETS FROM PROPERTY LINES AND INTERSECTIONS.
6. **PER NC IFC SECTION D103.2, FIRE APPARATUS ACCESS ROADS SHALL NOT EXCEED 10 PERCENT IN GRADE.
7. "A" BREAKOVER SHALL BE 8% OR LESS (A = ALGEBRAIC DIFFERENCE).
8. PRIOR APPROVAL IS REQUIRED BY CDOT ON GRADES EXCEEDING WHAT ARE SHOWN.
8. DRIVEWAY APRON MUST BE ASPHALT OR CONCRETE EXTENDED FROM EXISTING ROADWAY EDGE OF PAVEMENT TO THE RIGHT-OF-WAY LINE, OR BACK OF SIDEWALK, WHICHEVER IS GREATER.

DRIVEWAY APRON WIDTH		
	X	Y
TYPE I-RESIDENTIAL:		
LOCAL/COLLECTOR	10' MIN.	30' MAX.***
ARTERIAL *	15' MIN.	30' MAX.***

* MUST PROVIDE ON-SITE TURNAROUND
 *** MAXIMUM WIDTH INCLUDES OPTIONAL WINGS

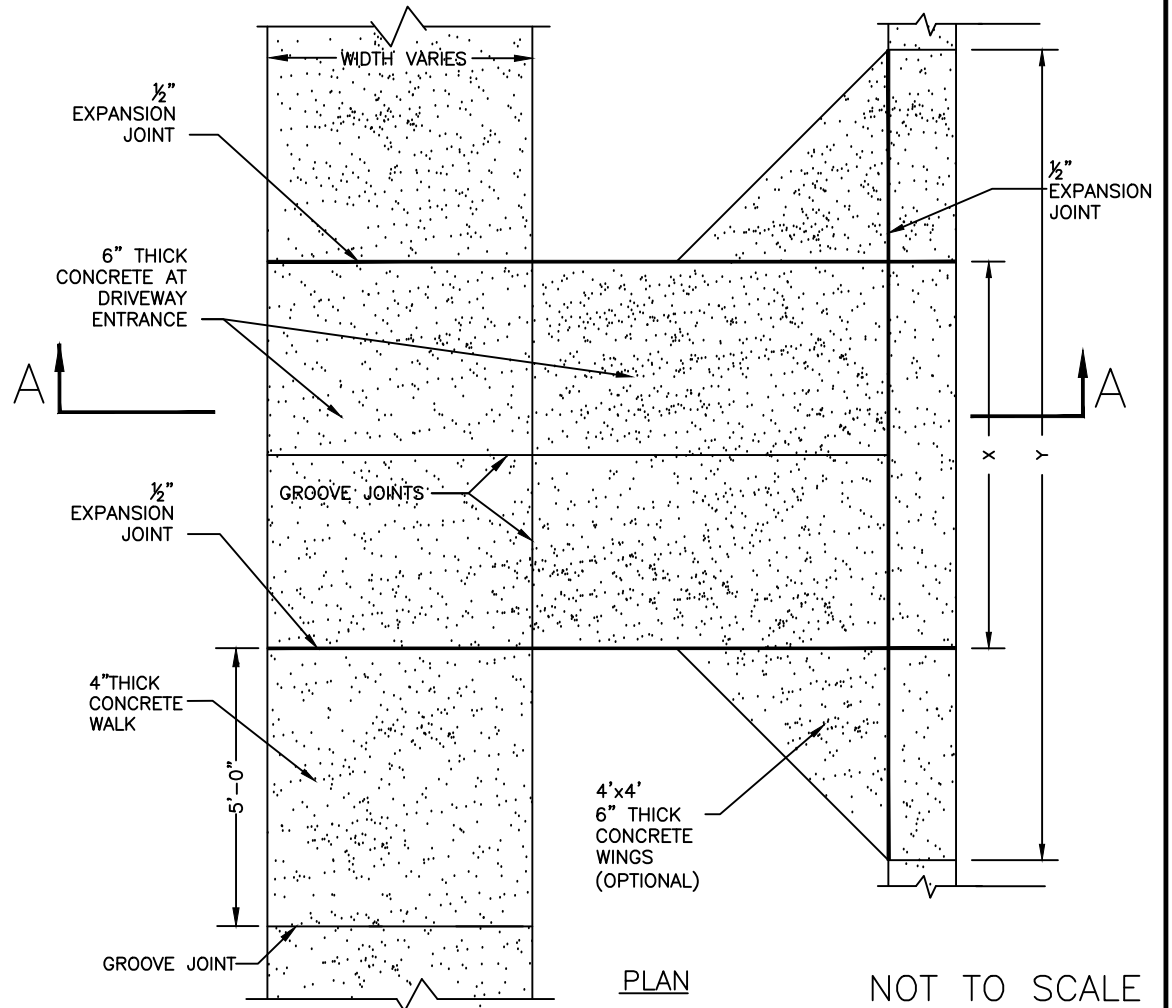

CITY OF CHARLOTTE
LAND DEVELOPMENT STANDARDS
 INCLUDES CHARLOTTE ETJ

RESIDENTIAL DRIVEWAY (TYPE I)
 FOR 2'-0" VALLEY GUTTER

STD. NO.	REV.
10.27A	25

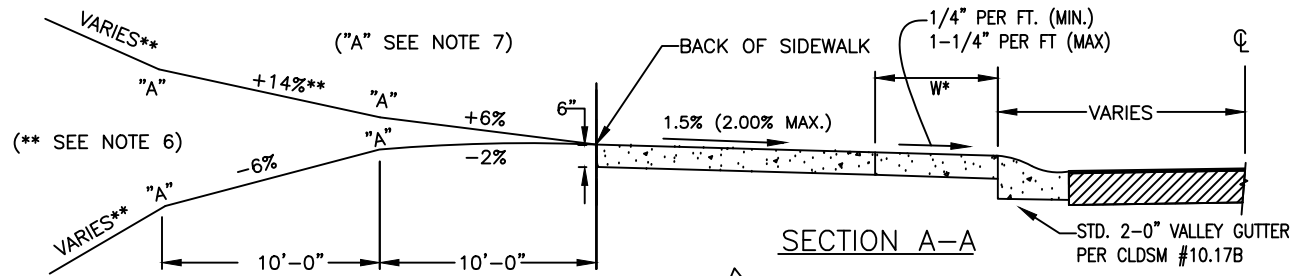
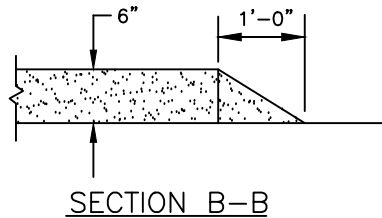

NOTES:

1. THE ELEVATION OF THE SIDEWALK SHALL BE NOT LESS THAN SIX INCHES OR MORE THAN EIGHTEEN INCHES ABOVE THE ROADWAY CROWN. THIS ELEVATION DIFFERENTIAL SHALL BE CONSISTENT WITHIN EACH BLOCK.
2. ALL CONCRETE TO BE 3600 PSI STRENGTH.
3. ALL CONSTRUCTION PRACTICES, INCLUDING COMPACTION, CURING, FINISHING, ETC. SHALL BE IN ACCORDANCE WITH THE CHARLOTTE LAND DEVELOPMENT STANDARDS.
4. PLANTING STRIP SHALL BE GRADED WITH A CROSS SLOPE BETWEEN 1/4 IN. PER FOOT AND 1 1/4 IN. PER FOOT EXCEPT WHERE EXCESSIVE NATURAL GRADES MAKE THIS REQUIREMENT IMPRACTICAL. IN SUCH CASES, THE CITY ENGINEER MAY AUTHORIZE A SUITABLE GRADE.
5. ALL DRIVEWAYS MUST MEET THE CURRENT CITY DRIVEWAY REGULATIONS AND NCDOT REQUIREMENTS, INCLUDING BUT NOT LIMITED TO SPACING, SIGHT DISTANCE, AND OFFSETS FROM PROPERTY LINES AND INTERSECTIONS.
6. PER NC IFC SECTION D103.2, FIRE APPARATUS ACCESS ROADS SHALL NOT EXCEED 10 PERCENT IN GRADE.
7. "A" BREAKOVER SHALL BE 8% OR LESS (A=ALGEBRAIC DIFFERENCE).
8. PRIOR APPROVAL IS REQUIRED BY CDOT ON GRADES EXCEEDING WHAT ARE SHOWN.
9. DRIVEWAY APRON MUST BE ASPHALT OR CONCRETE EXTENDED FROM EXISTING ROADWAY EDGE OF PAVEMENT TO THE RIGHT-OF-WAY LINE, OR BACK OF SIDEWALK, WHICHEVER IS GREATER.

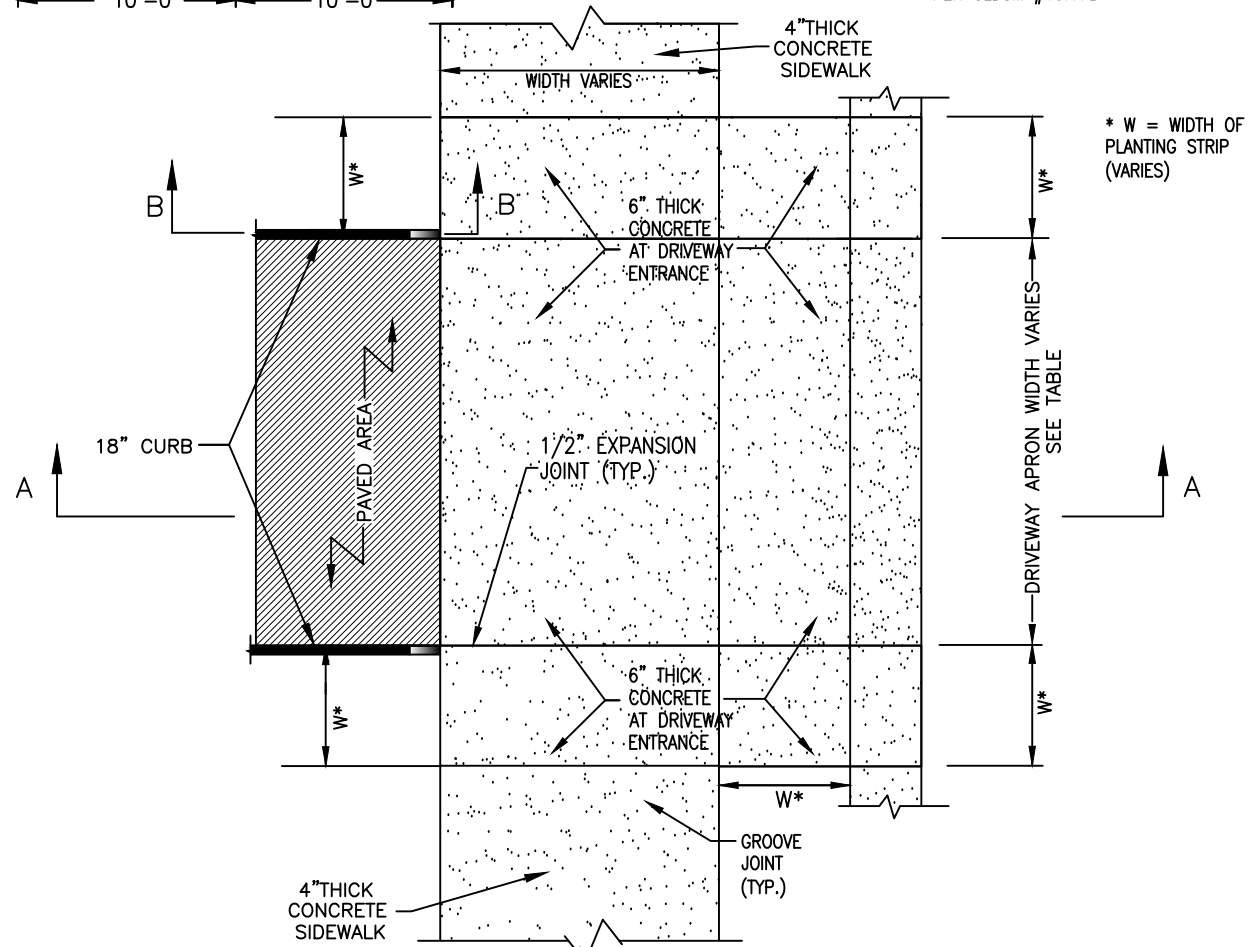

DRIVEWAY APRON WIDTH		
TYPE DRIVEWAY	MINIMUM	MAXIMUM
ONE-WAY TYPE II COMMERCIAL	20'	30'
TWO-WAY TYPE II COMMERCIAL	26'	50'

PLAN NOT TO SCALE



CITY OF CHARLOTTE
LAND DEVELOPMENT STANDARDS
INCLUDES CHARLOTTE ETJ

COMMERCIAL TYPE II DRIVEWAY
FOR 2'-0" VALLEY GUTTER

STD. NO.	REV.
10.27B	25

NOTES:

1. WHERE A TYPE III DRIVEWAY IS APPROVED BY THE CHARLOTTE DEPARTMENT OF TRANSPORTATION (CDOT) THAT CONNECTS TO AN EXISTING SIGNALIZED INTERSECTION, OR AT A LOCATION WHERE A TRAFFIC SIGNAL INSTALLATION IS PROPOSED BY CDOT BASED ON A TRAFFIC IMPACT/SIGNAL WARRANT STUDY, A FULL DEPTH ASPHALT PAVEMENT IS REQUIRED. THIS PAVEMENT DESIGN IS REQUIRED IN THE DRIVEWAY EASEMENT (100-FOOT MINIMUM) TO MAINTAIN DETECTOR LOOPS AND PAVEMENT MARKINGS. A TRAFFIC SIGNAL WILL BE INSTALLED ONLY IF CDOT DETERMINES THAT ONE IS NECESSARY BASED ON A TRAFFIC STUDY OF CURRENT CONDITIONS.
2. A CONCRETE GUTTER IS TO BE USED EXCEPT AT EXISTING OR PROPOSED TRAFFIC SIGNAL LOCATIONS. AT THESE LOCATIONS ADDITIONAL DRAINAGE REQUIREMENTS WILL BE NECESSARY TO ELIMINATE THE NEED FOR GUTTER ACROSS THE DRIVEWAY CONNECTIONS.
3. THE DRIVEWAY MUST RISE 6" FROM THE GUTTER LINE TO PREVENT RUNOFF FROM ENTERING DRIVEWAY.
4. ALL DRIVEWAYS MUST MEET THE CURRENT CITY DRIVEWAY REGULATIONS AND NCDOT REQUIREMENTS FOR SPACING, SIGHT DISTANCE, AND OFFSETS FROM PROPERTY LINES AND INTERSECTIONS.
5. TWO (2) CURB RAMPS PER CURB RETURN REQUIRED AT SIGNALIZED INTERSECTIONS.
6. FOUR (4) FOOT GUTTER AND WINGS ARE REQUIRED TO DIRECT WATER ACROSS DRIVE. GUTTER AND WINGS MAY NOT BE REQUIRED IF THE DRIVEWAY GUTTER SLOPE IS GREATER THAN 2%.
7. MAINTAIN UP TO 1.5% (MAX. 2%) CROSS-SLOPE ON THE PEDESTRIAN ACCESS ROUTE BETWEEN CURB RAMPS. CONCRETE IS OPTIONAL FOR THE CROSSWALK AREA IN THE DRIVEWAY.
8. DRIVEWAY APRON MUST BE ASPHALT OR CONCRETE EXTENDED FROM EXISTING ROADWAY EDGE OF PAVEMENT TO THE RIGHT-OF-WAY LINE, OR BACK OF SIDEWALK, WHICHEVER IS GREATER.

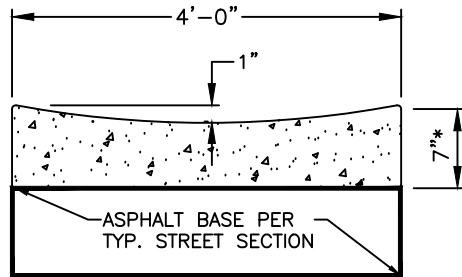
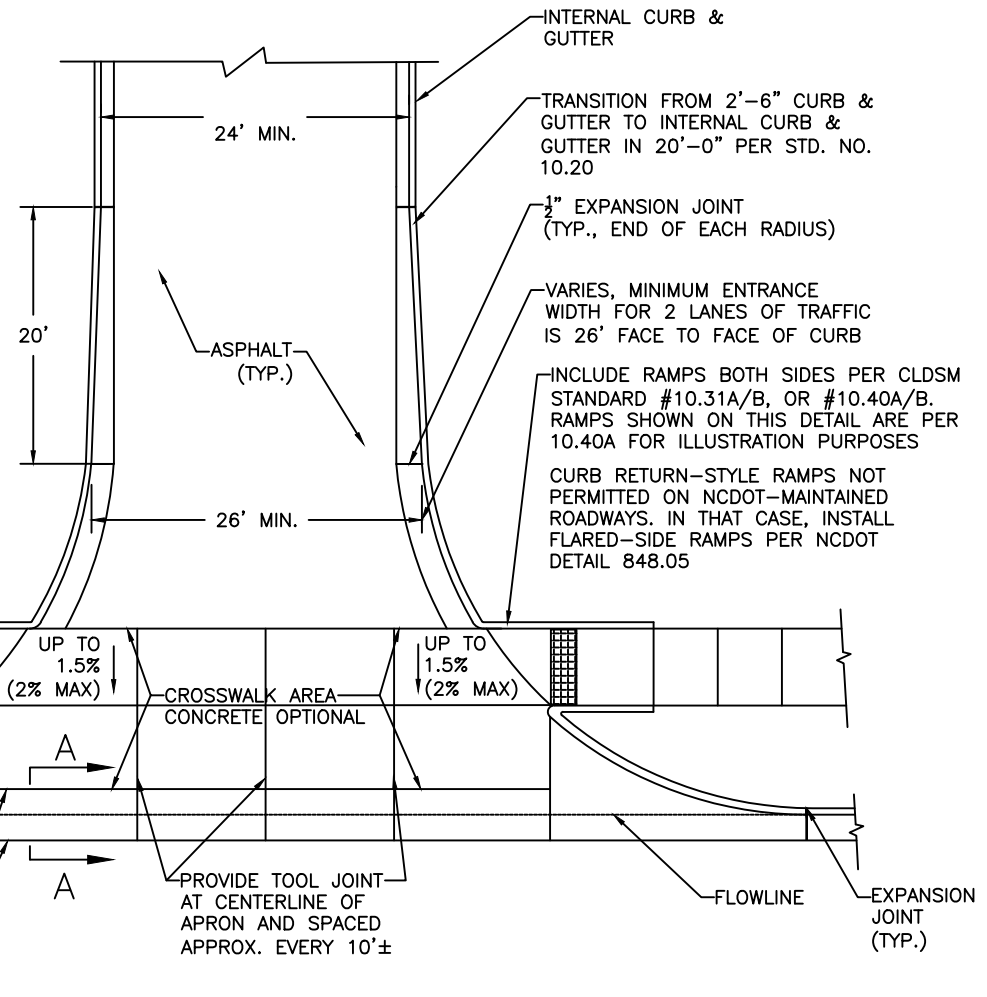

SECTION A-A

* TRANSITION CONCRETE DEPTH FROM 7" AT LIP TO 10" AT 4' CONCRETE GUTTER CONSTRUCTION JOINT IF NO ASPHALT BASE INSTALLED. IF ASPHALT BASE IS USED, 7" CONCRETE DEPTH CAN BE CARRIED THROUGH THE 4' CONCRETE GUTTER.

NOT TO SCALE



CITY OF CHARLOTTE
LAND DEVELOPMENT STANDARDS
 INCLUDES CHARLOTTE ETJ

TYPE III DRIVEWAY ENTRANCE

STD. NO.	REV.
10.28	25

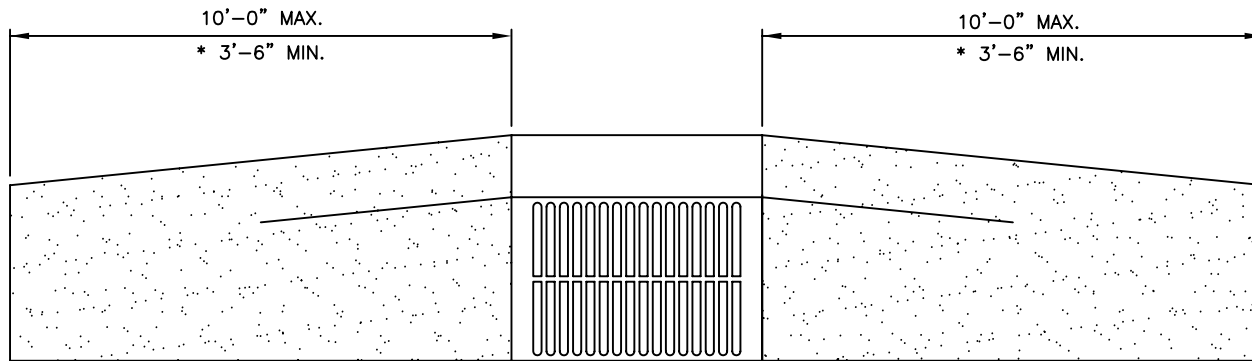

PLAN

NOTE:

- * TRANSITION FROM 2'-6" STANDARD CURB TO VALLEY CURB AT A DRAINAGE INLET ONLY.
- SEE STANDARD 10.19 FOR CROSS SECTION GEOMETRY.

NOT TO SCALE



CITY OF CHARLOTTE
 LAND DEVELOPMENT STANDARDS
 INCLUDES CHARLOTTE ETJ

CATCH BASIN FRAME
 IN VALLEY GUTTER

STD. NO.	REV.
10.29	

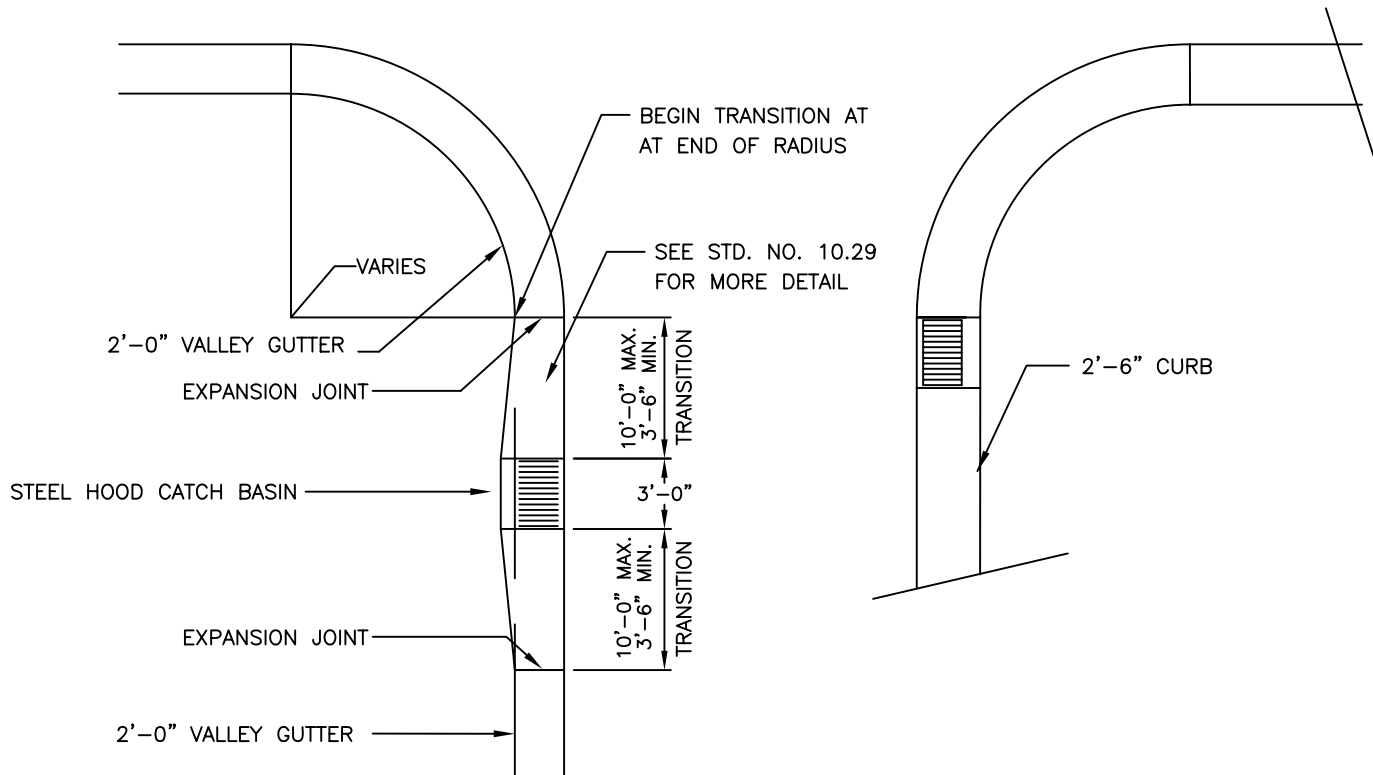

NOTE:

1. WHERE 2'-6" CURB AND GUTTER IS USED, CATCH BASINS MAY BE LOCATED AT END OF RADIUS.
2. RADIUS AT INTERSECTION MAY VARY.

NOT TO SCALE



**CITY OF CHARLOTTE
LAND DEVELOPMENT STANDARDS**
INCLUDES CHARLOTTE ETJ

CATCH BASIN PLACEMENT AT INTERSECTIONS

STD. NO.	REV.
10.30	

NOTES:

1. ENSURE FLUSH CONDITIONS AT CURB RAMP TO GUTTER TRANSITION.
2. TYPICALLY, THE SIDEWALK RUNNING SLOPE SHALL NOT EXCEED THE GENERAL GRADE ESTABLISHED FOR THE ADJACENT STREET.
3. IF THE SLOPE FROM FLOWLINE TO BACK OF CURB AT RAMP IS LESS THAN 8.33%, THEN THE SLOPE FROM LIP TO FLOWLINE AT RAMP MAY EXCEED 5% AS LONG AS THE ALGEBRAIC DIFFERENCE BETWEEN THESE TWO SLOPES IS LESS THAN 13.33%.

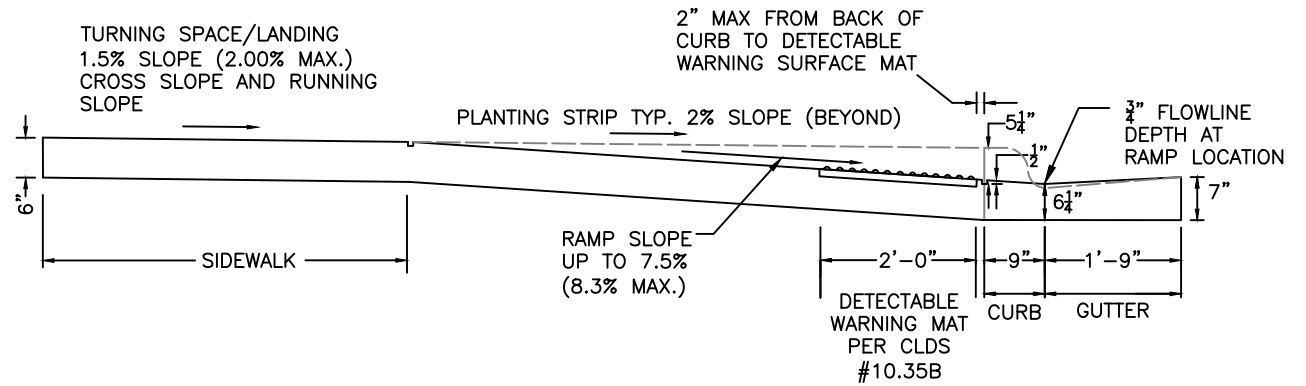
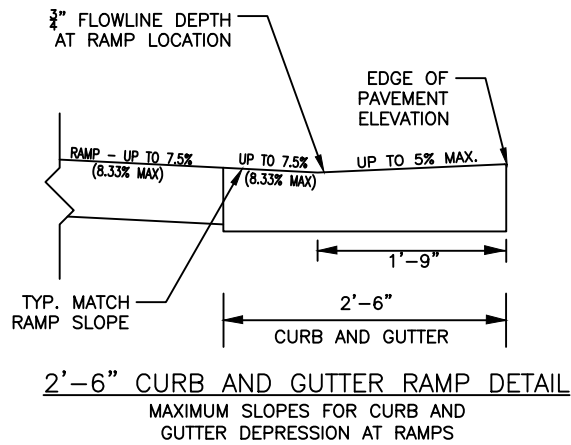
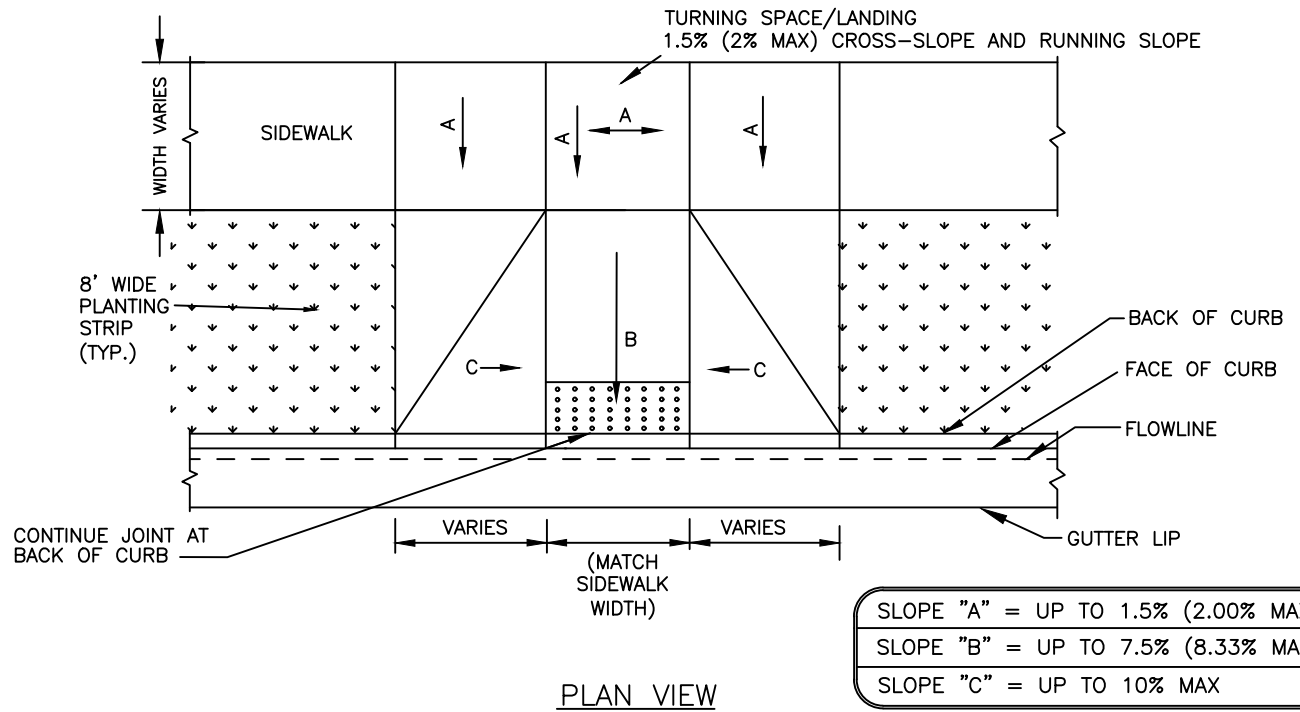

TYPICAL RAMP SECTION AT CENTERLINE

NOT TO SCALE



CITY OF CHARLOTTE
LAND DEVELOPMENT STANDARDS
INCLUDES CHARLOTTE ETJ

PERPENDICULAR CURB RAMP
WITH 2'-6" CURB AND GUTTER

STD. NO.	REV.
10.31A	23

NOTES:

1. THIS DETAIL PRESENTS ALTERNATIVE TREATMENTS FOR THE SIDES OF THE RAMP – RETURNED CURBS, RECTANGULAR WINGS, AND ANGLED WINGS.
2. ENSURE FLUSH CONDITIONS AT CURB RAMP TO GUTTER TRANSITION.
3. TYPICALLY, THE SIDEWALK RUNNING SLOPE SHALL NOT EXCEED THE GENERAL GRADE ESTABLISHED FOR THE ADJACENT STREET.
4. CURB RAMPS WITH RETURNED CURBS MAY BE USED ONLY WHERE PEDESTRIANS WOULD NOT TYPICALLY WALK ACROSS THE RAMP, THE ADJACENT SURFACE IS PLANTING OR OTHER NON-WALKING SURFACE, OR THE SIDE APPROACH IS SUBSTANTIALLY OBSTRUCTED.

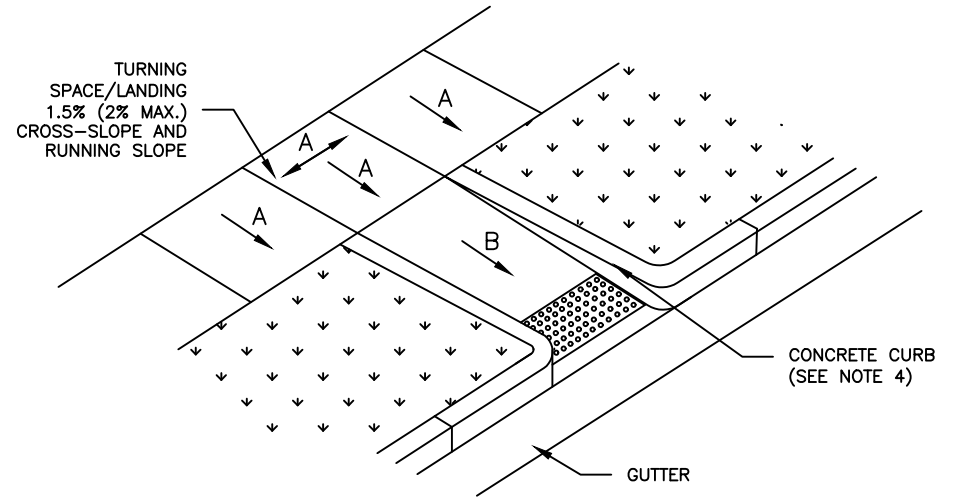

ALTERNATIVE 1: RETURNED CURBS

(SEE NOTE 4)

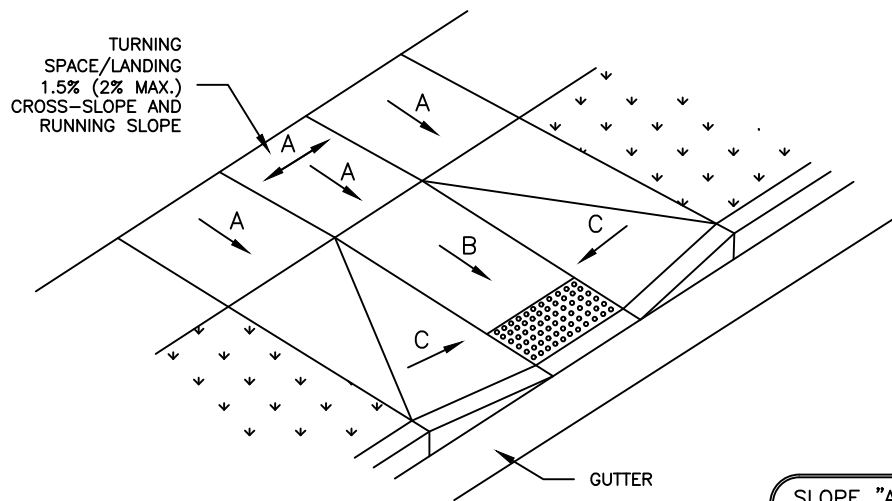

ALTERNATIVE 2: RECTANGULAR FLARES

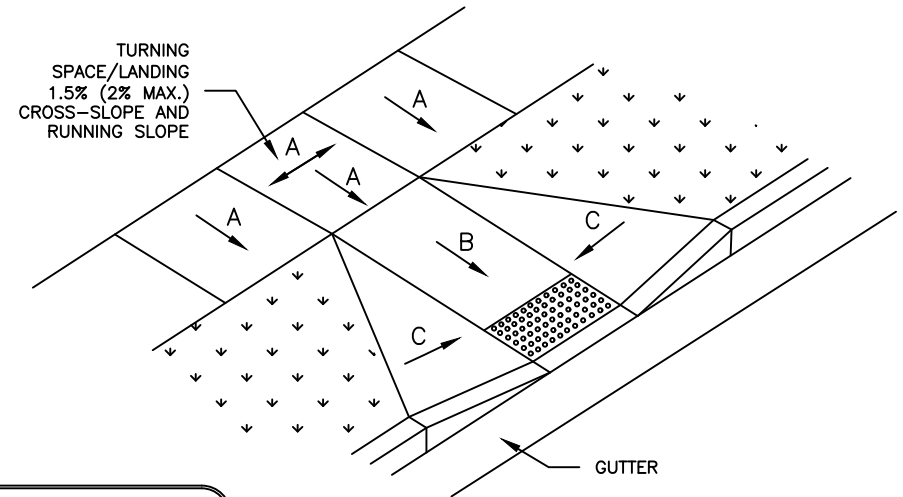

ALTERNATIVE 3: ANGLED FLARES

NOT TO SCALE

SLOPE "A" = UP TO 1.5% (2.00% MAX)
SLOPE "B" = UP TO 7.5% (8.33% MAX)
SLOPE "C" = UP TO 10% MAX



CITY OF CHARLOTTE
LAND DEVELOPMENT STANDARDS
INCLUDES CHARLOTTE ETJ

PERPENDICULAR CURB RAMP WITH
2'-6" CURB AND GUTTER

STD. NO.	REV.
10.31B20	

NOTES:

1. ENSURE FLUSH CONDITIONS AT CURB RAMP TO GUTTER TRANSITION.
2. TYPICALLY, THE SIDEWALK RUNNING SLOPE SHALL NOT EXCEED THE GENERAL GRADE ESTABLISHED FOR THE ADJACENT STREET.
3. MAINTAIN POSITIVE DRAINAGE ALONG THE LIP OF GUTTER IN RAMP. IN FLAT AREAS, ADDITIONAL CATCH BASINS MAY BE REQUIRED ON THE SIDES OF THE RAMP TO MINIMIZE STANDING WATER AT THE RAMP LOCATION.
4. IF THE SLOPE FROM FLOWLINE TO BACK OF CURB AT RAMP IS LESS THAN 8.3%, THEN THE SLOPE FROM LIP TO FLOWLINE AT RAMP MAY EXCEED 5% AS LONG AS THE DIFFERENCE BETWEEN THESE TWO SLOPES IS LESS THAN 13.3%.

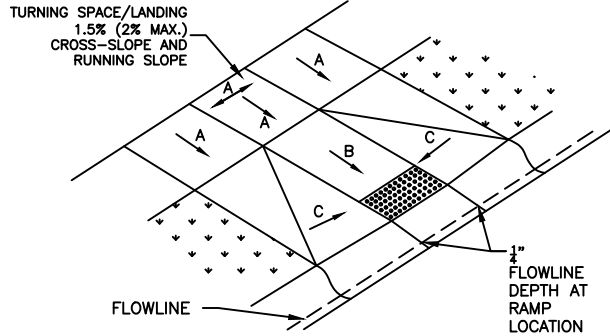

ISOMETRIC VIEW

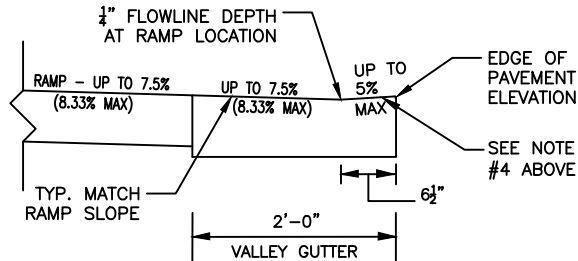

2'-0" VALLEY GUTTER RAMP DETAIL

MAXIMUM SLOPES FOR VALLEY GUTTER DEPRESSION AT RAMPS

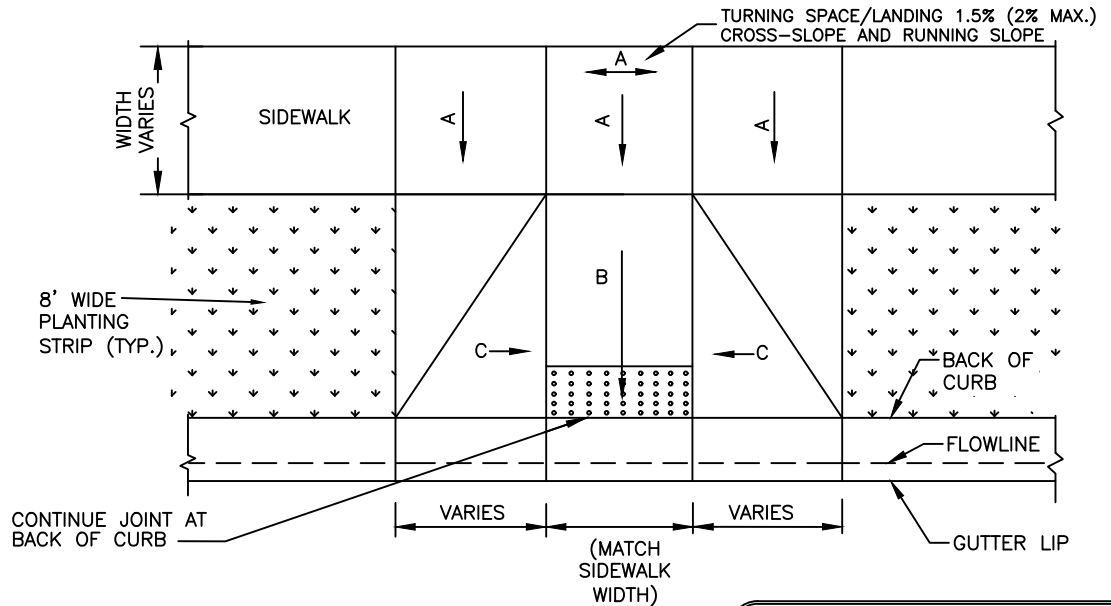

PLAN VIEW

SLOPE "A" = UP TO 1.5% (2.00% MAX)
SLOPE "B" = UP TO 7.5% (8.33% MAX)
SLOPE "C" = UP TO 10% MAX

NOT TO SCALE

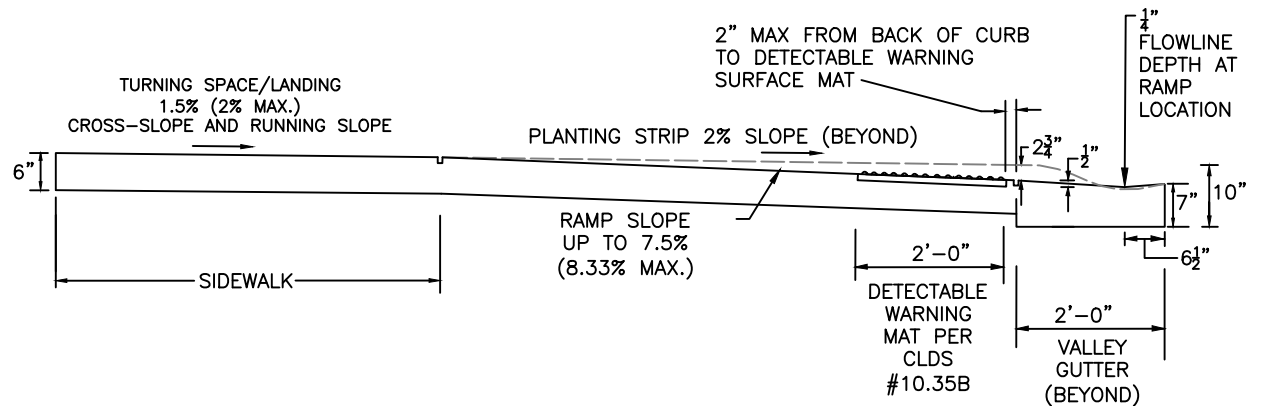

TYPICAL RAMP SECTION AT CENTERLINE

NOT TO SCALE



**CITY OF CHARLOTTE
LAND DEVELOPMENT STANDARDS**
INCLUDES CHARLOTTE ETJ

**PERPENDICULAR CURB RAMP
WITH 2'-0" VALLEY GUTTER**

STD. NO.	REV.
10.33	23

NOTES:

1. MAINTAIN A MINIMUM OF 0.5% SLOPE ON ALL CONCRETE SURFACES TO PROMOTE SURFACE DRAINAGE TOWARD CURB.
2. GUTTER FLOW LINE AND PLAN PROFILE SHALL BE MAINTAINED THROUGH THE RAMP AREA.
3. THE SURFACE OF THE RAMP SHALL BE FLUSH WITH THE FLOWLINE OF THE CURB AND GUTTER.
4. THE WING AND RAMP SURFACES SHALL BE 3600 PSI CONCRETE WITH A SIDEWALK FINISH IN ACCORDANCE WITH CURRENT EDITION NCDOT STANDARD SPECIFICATIONS FOR ROADS AND STRUCTURES.
5. DRAINAGE STRUCTURES, MAST ARMS, LIGHT POLES AND OTHER OBSTRUCTIONS SHALL NOT BE PLACED IN LINE WITH RAMPS. LOCATION OF THE RAMP SHALL TAKE PRECEDENCE OVER LOCATION OF OBSTRUCTIONS EXCEPT WHERE EXISTING OBSTRUCTIONS ARE BEING UTILIZED IN THE NEW CONSTRUCTION.
6. SEE STANDARD DRAWING 10.35B FOR DETECTABLE WARNING INSTALLATION.
7. SEE USDG INTERSECTION DIAGRAMS I-1 THROUGH I-3 FOR TYPICAL RAMP PLACEMENT AND INTERSECTION LAYOUTS.
8. CURB RAMPS SHALL HAVE A SEGMENT OF STRAIGHT CURB AT LEAST 24 INCHES LONG LOCATED ON EACH SIDE OF THE WING SLOPE AND WITHIN THE CROSSWALK MARKINGS.
9. FOR ALL RAMPS AT MARKED CROSSWALKS THE RAMP OPENING (AT THE FULLY DEPRESSED CURB) SHALL BE LOCATED WITHIN THE PARALLEL BOUNDARIES OF CROSSWALK MARKINGS.
10. IF A SINGLE DIAGONAL RAMP ON A CORNER IS USED (TYP. ONLY IN RETROFITS), THE RAMP CENTERLINE SHALL BE LOCATED AT THE CORNER RADIUS CENTERLINE UNLESS OTHERWISE DIRECTED BY THE ENGINEER. A MIN. 4'X4' CLEAR SPACE BEYOND THE CURB FACE MUST BE WHOLLY OUTSIDE OF THE PARALLEL VEHICLE TRAVEL LANE (SEE DIAGRAM BELOW):

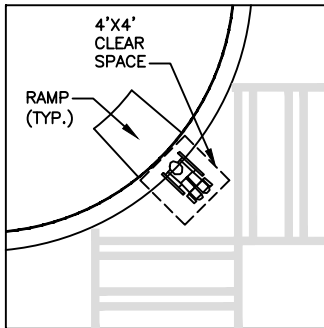

- CLEAR SPACE:**
- 4' X 4' MINIMUM
 - BEYOND BOTTOM GRADE BREAK
 - WITHIN PEDESTRIAN STREET CROSSING
 - OUTSIDE PARALLEL VEHICLE TRAVEL LANE

SLOPE "A" 1.5% (2.00% MAX)
SLOPE "B" 7.5% (8.33% MAX)
SLOPE "C" 10% MAX

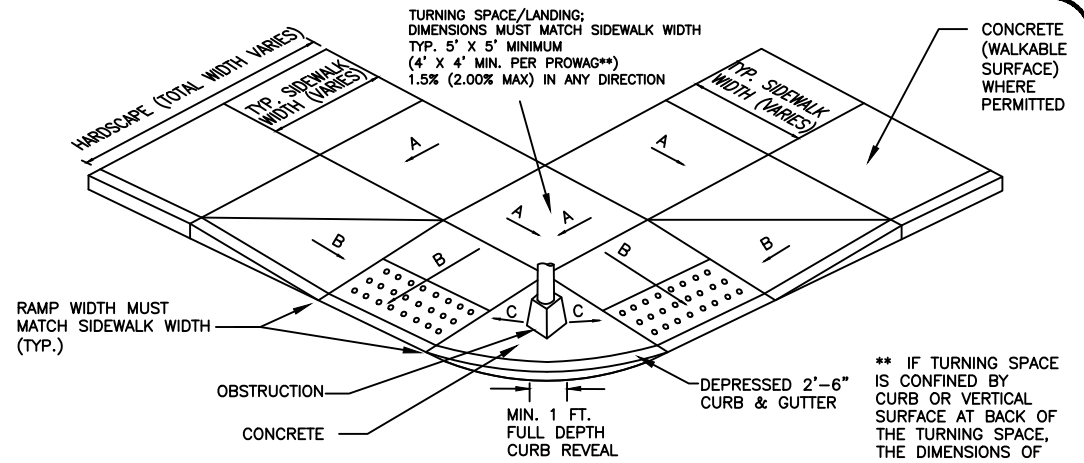

** IF TURNING SPACE IS CONFINED BY CURB OR VERTICAL SURFACE AT BACK OF THE TURNING SPACE, THE DIMENSIONS OF TURNING SPACE MUST BE 5'X5' MINIMUM.

TURNING SPACE DIMENSIONS AND RAMP WIDTH MUST MATCH SIDEWALK WIDTH.

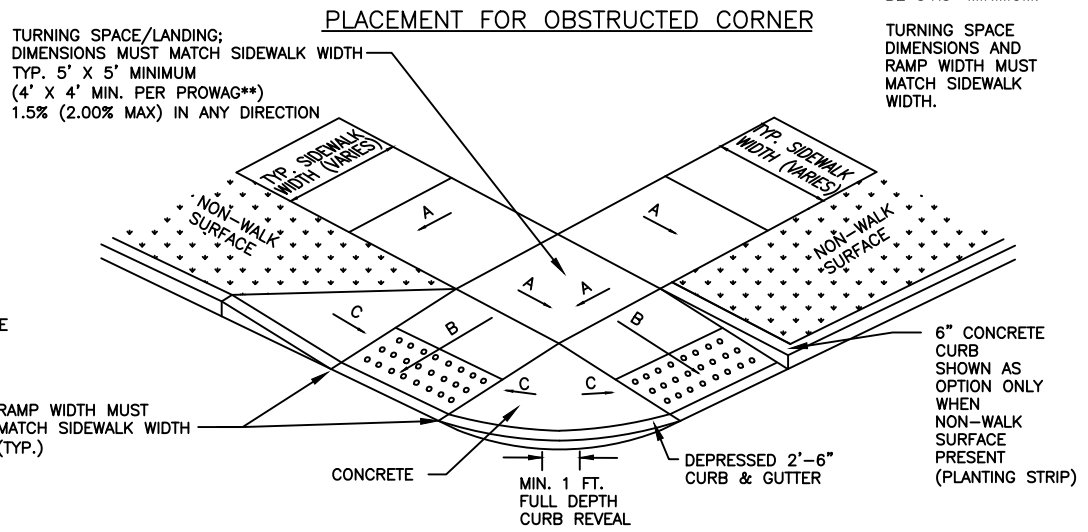

PLACEMENT FOR SMALL CORNER RADIUS

NOT TO SCALE



CITY OF CHARLOTTE
LAND DEVELOPMENT STANDARDS
 INCLUDES CHARLOTTE ETJ

PLACEMENT OF CURB RAMPS AT OBSTRUCTED OR SMALL CORNER RADIUS

STD. NO.	REV.
10.35A	17

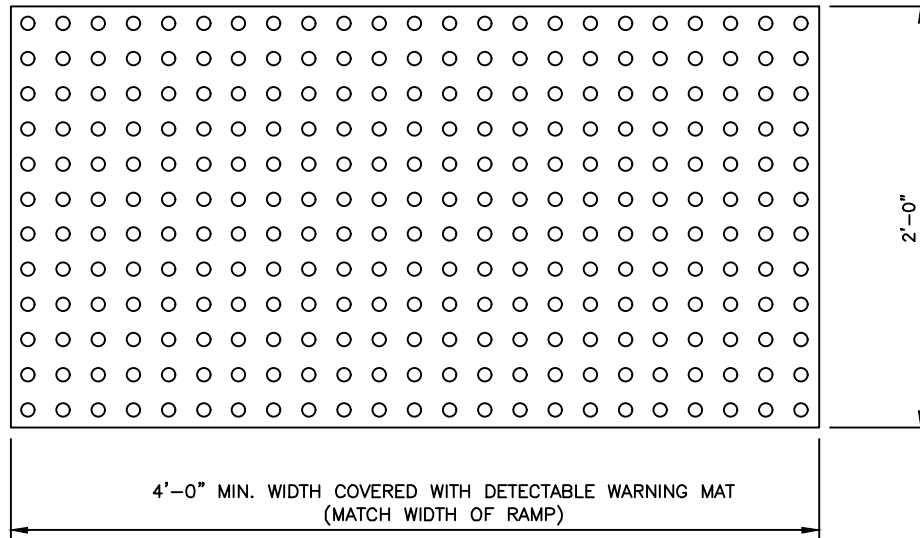

TRUNCATED DOME PLAN VIEW

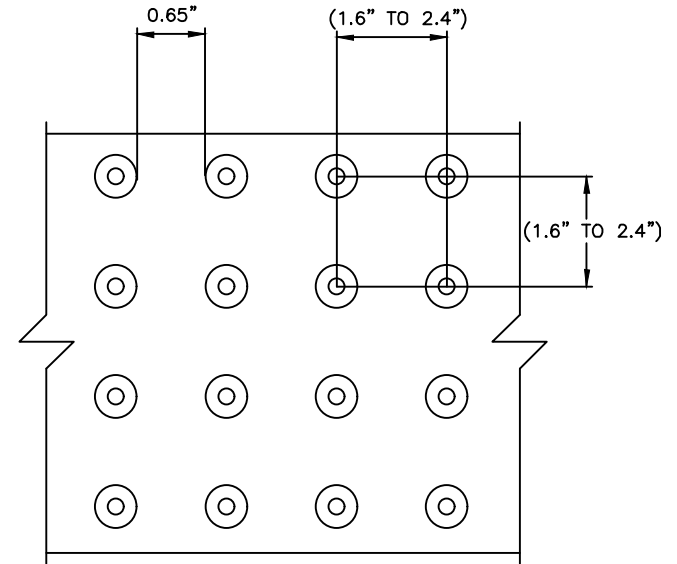

TRUNCATED DOME SPACING

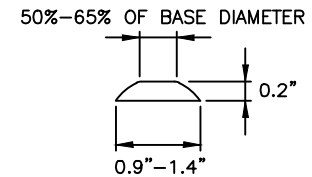

TRUNCATED DOME SECTION

NOTES:

1. ALL DETECTABLE WARNING DEVICES USED IN NEW CONSTRUCTION SHALL BE OF A RIGID PRECAST OR EMBEDDED PRODUCT APPROVED BY THE CITY ENGINEER. RETROFIT MATS WILL ONLY BE ALLOWED ON EXISTING RAMPS WITH PRIOR APPROVAL OF THE CITY ENGINEER FOR MATERIAL TYPE AND INSTALLATION (IE. RESURFACING).
2. RAMP AND DETECTABLE WARNING AREA SHALL BE A MINIMUM OF 4 FEET IN WIDTH, BUT NOT LESS THAN THE WIDTH OF SIDEWALK LEADING TO BACK OF RAMP.
3. DETECTABLE WARNING SURFACES SHALL EXTEND 2.0 FT MINIMUM IN THE DIRECTION OF PEDESTRIAN TRAVEL.
4. DETECTABLE WARNING AREA CAN BE PLACED SQUARE WHERE USED IN A CURB RADIUS.
5. THE ROWS OF TRUNCATED DOMES IN DETECTABLE WARNING SURFACES SHOULD BE ALIGNED PERPENDICULAR TO THE GRADE BREAK BETWEEN THE RAMP RUN AND THE STREET. WHERE DETECTABLE WARNING SURFACES ARE PROVIDED ON A SURFACE WITH A SLOPE THAT IS LESS THAN 5 PERCENT, DOME ORIENTATION IS LESS CRITICAL.
6. DETECTABLE WARNING AREA SHALL CONTRAST VISUALLY WITH ADJACENT GUTTER, STREET OR HIGHWAY, OR PEDESTRIAN ACCESS ROUTE SURFACE; EITHER LIGHT-ON-DARK OR DARK-ON-LIGHT. ON THE TRYON STREET MALL, FRENCH GRAY IS TO BE USED.
7. IF PAVERS ARE TO BE USED, PAVERS SHALL BE MINIMUM 8000 PSI CONCRETE WITH A 2-INCH MINIMUM THICKNESS, SET ON A THIN-SET MORTAR ON TOP OF 4" THICK 3600 PSI CONCRETE BASE.
8. MATS ARE TO BE RIGID WITH TURNED-DOWN EDGES EMBEDDED IN CONCRETE TO ELIMINATE TRIP HAZARD.
9. DIMENSIONS PER NCDOT 848.06

NOT TO SCALE



CITY OF CHARLOTTE
LAND DEVELOPMENT STANDARDS
INCLUDES CHARLOTTE ETJ

TRUNCATED DOMES
PLAN AND CROSS-SECTION

STD. NO.	REV.
10.35B	15

- (H) 2'-6" OR 2'-0" STANDARD CURB AND GUTTER, STD. PER 10.17A
- (M) SAFETY RAIL, STD. 50.04A & 50.04B
- (S) CONCRETE SIDEWALK, STD. 10.22 OR SHARED USE PATH, STD. 10.42
- (H1) 2'-0" VALLEY GUTTER. STD. 10.17B
- (H2) CURB TRANSITION STANDARD CURB AND GUTTER TO 2'-0" VALLEY GUTTER, STD. 10.19

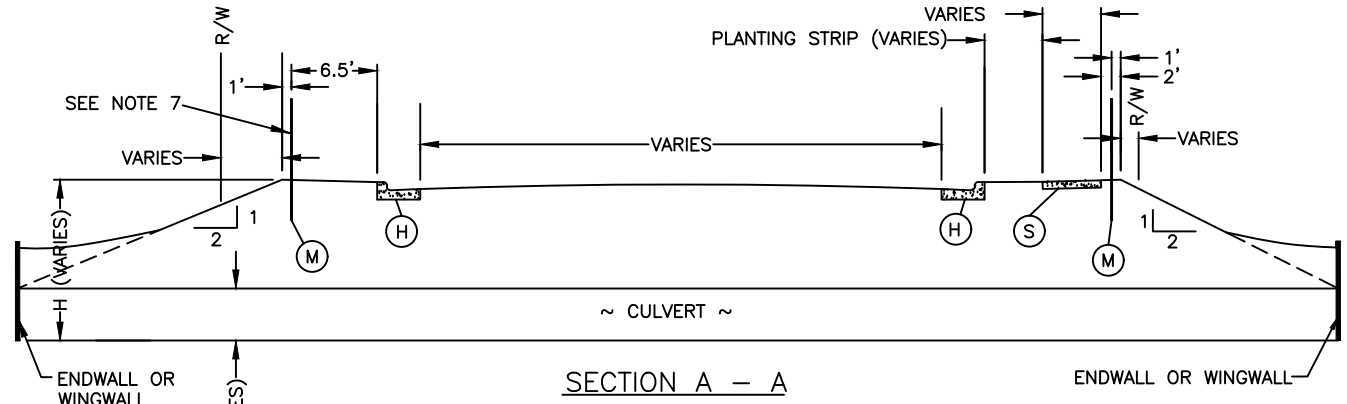

- LH = DISTANCE FROM END OF WINGWALL TO END OF SAFETY RAIL.
- LC1 = DISTANCE FROM \hat{C} OF CULVERT TO END OF 2'-6" CURB AND GUTTER GUTTER.
- LC2 = DISTANCE FROM END OF WINGWALL TO END OF 2'-6" CURB AND GUTTER.

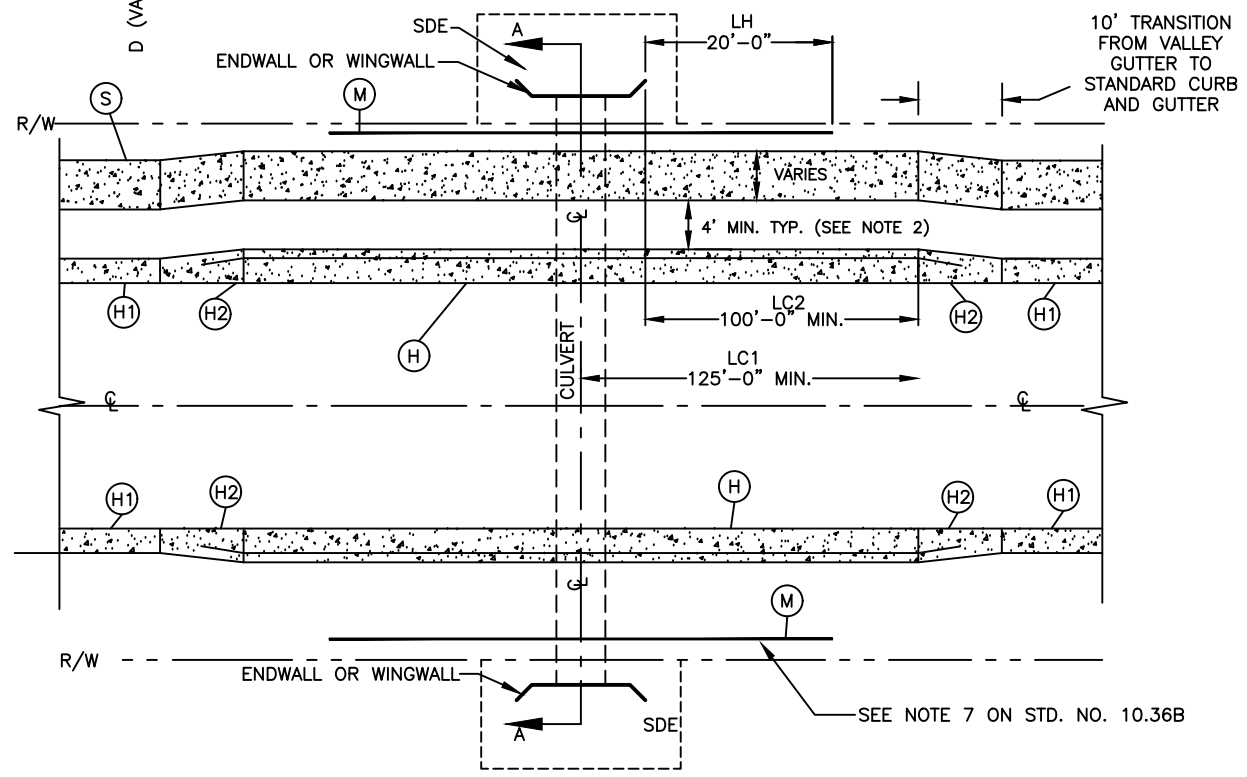

NOTES:

1. SEE STD. NO. 10.36B FOR GENERAL NOTES AND CLEAR ZONE DISTANCES.
2. AN ALTERNATIVE FOR STREETS WITH WIDER PLANTING STRIPS AND SIDEWALKS: IN LIEU OF A PLANTING STRIP ALONG THE CULVERT CROSSING, PROVIDE A MINIMUM 8-FOOT WIDE SIDEWALK LOCATED AT THE BACK OF CURB, FOR LENGTH "LC1" ON EITHER SIDE OF THE CULVERT CENTERLINE.



**CITY OF CHARLOTTE
LAND DEVELOPMENT STANDARDS**
INCLUDES CHARLOTTE ETJ

**CULVERT CROSSINGS ON RESIDENTIAL
AND COMMERCIAL STREETS**

STD. NO.	REV.
10.36A	24

GENERAL NOTES:

1. UNLESS OTHERWISE DETERMINED BY THE CITY, THE MEASURES ILLUSTRATED SHALL BE USED WHEN CULVERT DIAMETER, D, IS GREATER THAN OR EQUAL TO 24 INCHES AND WHEN THE DIFFERENCE IN ELEVATION BETWEEN THE CULVERT INVERT AND THE TOP OF SLOPE, H, IS GREATER THAN OR EQUAL TO 5 FEET.
2. INSTALLATION OF 2'-6" CURB AND GUTTER MAY NOT BE REQUIRED WHEN AN ADEQUATE CLEAR ZONE IS PROVIDED FOR VEHICLES WITH A MAXIMUM OF 6:1 SLOPE (SEE TABLE 1).
3. INSTALLATION OF SAFETY RAIL MAY NOT BE REQUIRED WHEN A 10-FOOT PEDESTRIAN CLEAR ZONE IS PROVIDED BEHIND THE SIDEWALK WITH A MAXIMUM OF 6:1 SLOPE. WHERE NO SIDEWALK IS REQUIRED, INSTALLATION OF SAFETY RAIL MAY NOT BE REQUIRED WHEN A 15-FOOT PEDESTRIAN CLEAR ZONE IS PROVIDED BEHIND THE CURB WITH A MAXIMUM OF 6:1 SLOPE.
4. FOR CULVERT CROSSINGS WITHOUT ENDWALLS, LH AND LC2 SHALL BE MEASURED FROM THE OUTSIDE OF THE NEAREST WALL OF THE CULVERT BARREL.
5. FOR MULTIPLE BARREL CULVERT CROSSINGS, LC1 SHALL BE MEASURED FROM THE CENTERLINES OF THE OUTBOARD CULVERT BARRELS.
6. WHEN NECESSARY, AS DETERMINED BY THE CITY, ADDITIONAL MEASURES MAY BE REQUIRED.
7. INSTALLATION OF SAFETY RAIL IS REQUIRED ON BOTH SIDES OF STREET IF SIDEWALK IS REQUIRED ON BOTH SIDES.
8. INSTALLATION OF SAFETY RAIL IS REQUIRED ON BOTH SIDES OF STREET IF NO SIDEWALK IS REQUIRED EXCEPT WHEN A 15-FOOT PEDESTRIAN CLEAR ZONE IS PROVIDED BEHIND THE CURB WITH A MAXIMUM OF 6:1 SLOPE.
9. INSTALLATION OF SAFETY RAIL IS REQUIRED ON THE SIDEWALK SIDE OF STREET IF SIDEWALK IS ONLY REQUIRED ON ONE SIDE OF STREET. INSTALL EITHER SAFTEY RAIL OR 15-FT CLEAR ZONE ON SIDE WITHOUT SIDEWALK.
10. DESIGN ADT IS CALCULATED ASSUMING A TRIP GENERATION OF 10 DAILY TRIPS PER SINGLE FAMILY DWELLING UNIT.

TABLE 1.
CLEAR ZONE DISTANCES
LOCAL, COLLECTOR, AND COMMERCIAL STREETS

DESIGN ADT	CLEAR ZONE FROM EDGE OF PAVEMENT	
	TANGENT SECTION	CURVE (WITHIN 125' OF CULVERT)
UNDER 750	10'	15'
750 - 1500	12'	18'
1501 - 6000	14'	21'
OVER 6000	16'	24'

SEE STD. NO. 10.36A FOR PLAN AND CROSS SECTIONAL SCHEMATICS.

NOT TO SCALE



CITY OF CHARLOTTE
LAND DEVELOPMENT STANDARDS
INCLUDES CHARLOTTE ETJ

CULVERT CROSSINGS ON RESIDENTIAL
AND COMMERCIAL STREETS

STD. NO.	REV.
10.36B	23

GENERAL NOTES:

1. ALL TAPERS ARE 20:1 AND OCCUR ON BOTH SIDERS OF THE ROAD TO BE TAPERED STARTING AT THE RADIUS RETURN AFTER THE INTERSECTION.
2. CENTERLINE OF BOTH STREETS IS MAINTAINED. NO SHIFTING OF THE CENTERLINE SHALL OCCUR.
3. RIGHT OF WAY AND SIDEWALK BEHIND TAPERED STREET SECTION TO TAPER OVER THE SAME STREET TAPER LENGTH.
4. DETAIL DOES NOT APPLY TO ARTERIALS, UPTOWN STREETS, OR MAIN STREETS. CDOT TO DETERMINE APPROPRIATE TAPERS IN THOSE SITUATIONS.

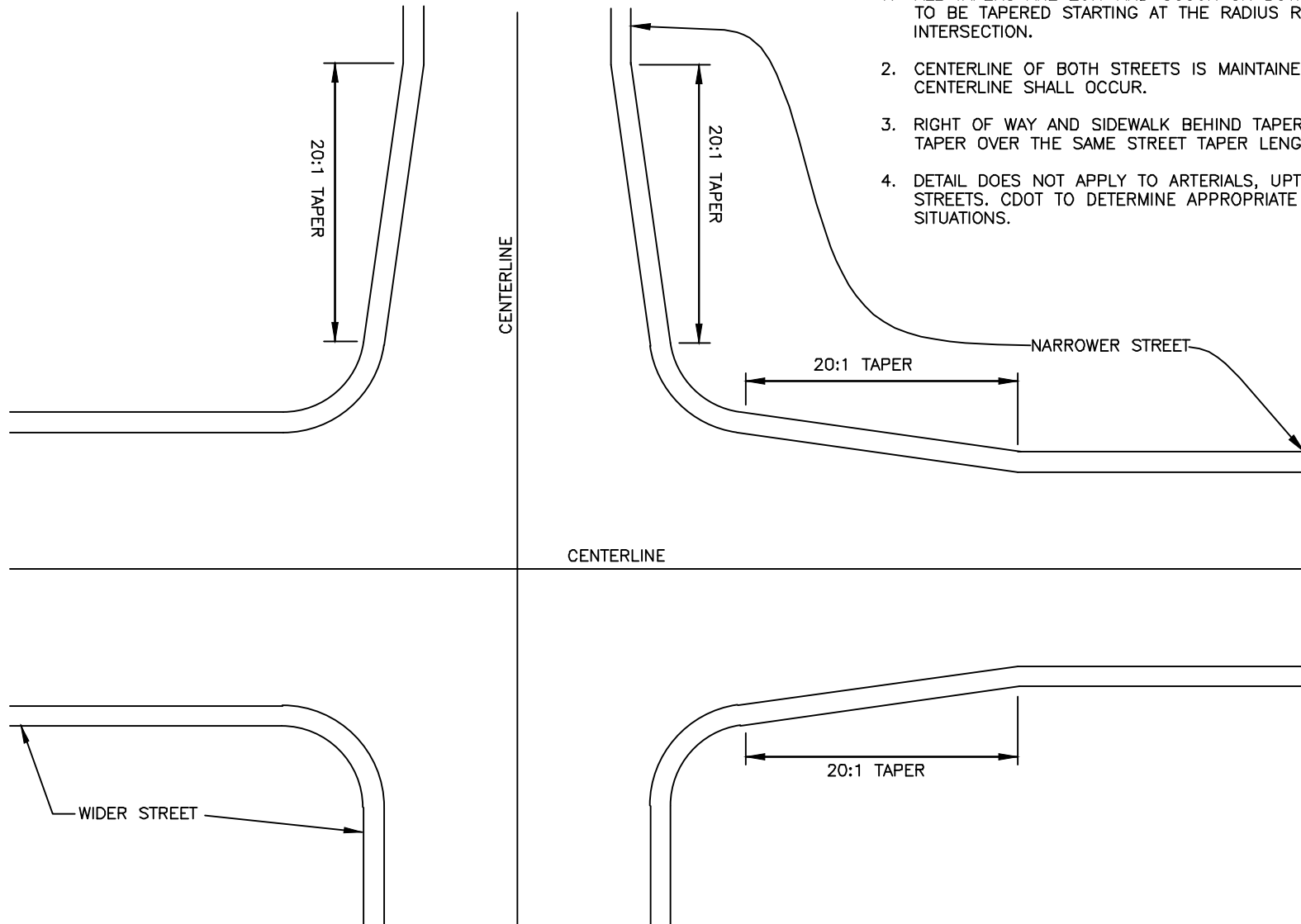

NOT TO SCALE



CITY OF CHARLOTTE
 LAND DEVELOPMENT STANDARDS
 INCLUDES CHARLOTTE ETJ

TYPICAL WIDER STREET TO
 NARROWER STREET TAPER

STD. NO.	REV.
10.37	23

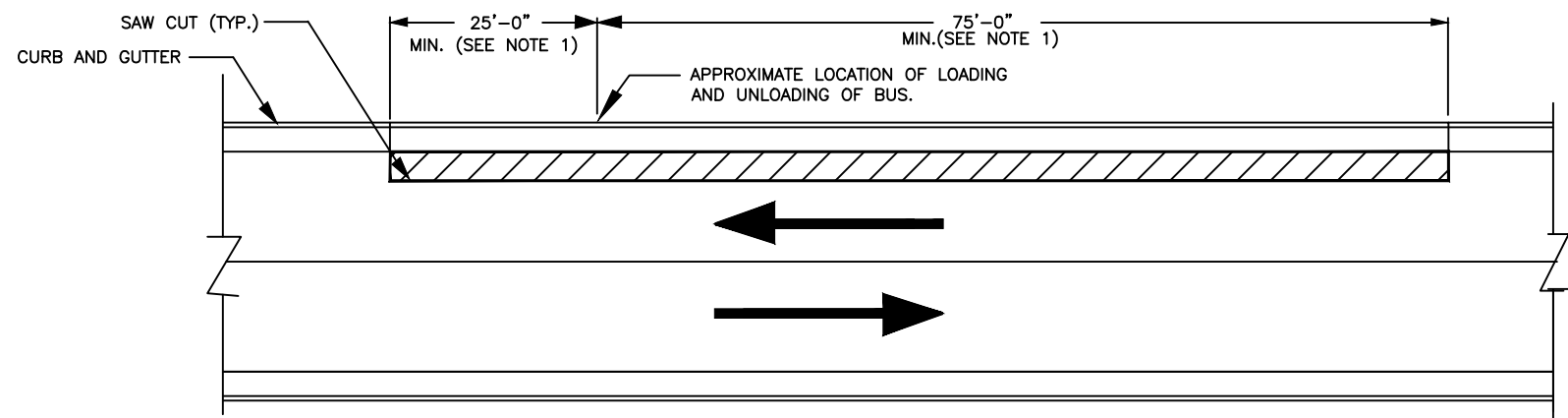
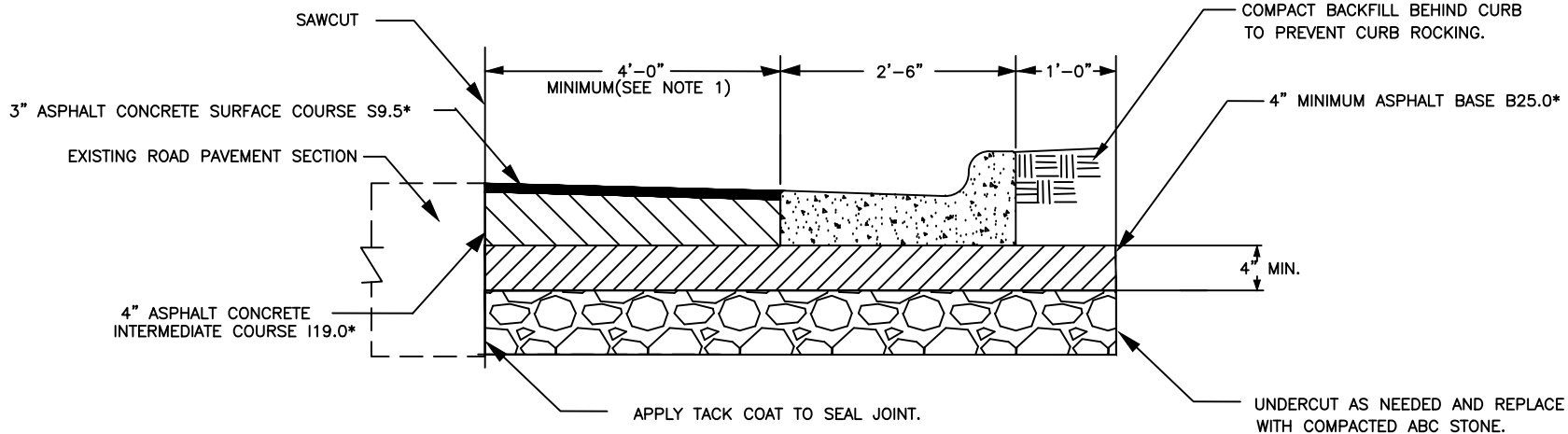

- NOTES:
1. ACTUAL SITE CONDITIONS MAY REQUIRE ADDITIONAL LIMITS OF CONSTRUCTION TO BE DETERMINED BY THE CITY (MINIMUM SHOWN).
 2. SEE APPROPRIATE CURB DETAIL FOR CURB INSTALLATION.
 3. CONCRETE SHALL BE A MINIMUM OF 3600 PSI.
 4. ASPHALT TYPE (*) TO MATCH SPECIFIED STREET DETAIL STANDARD PAVEMENT STRUCTURE OR AS DIRECTED BY CITY ENGINEER (SEE STREET TYPICAL DETAIL STANDARD).
 5. RESURFACING LIMITS ON NCDOT-MAINTAINED ROADS TO BE DETERMINED BY NCDOT.

NOT TO SCALE



CITY OF CHARLOTTE
LAND DEVELOPMENT STANDARDS
 INCLUDES CHARLOTTE ETJ

CURB REPAIRS AT EXISTING BUS STOPS

STD. NO.	REV.
10.38	23

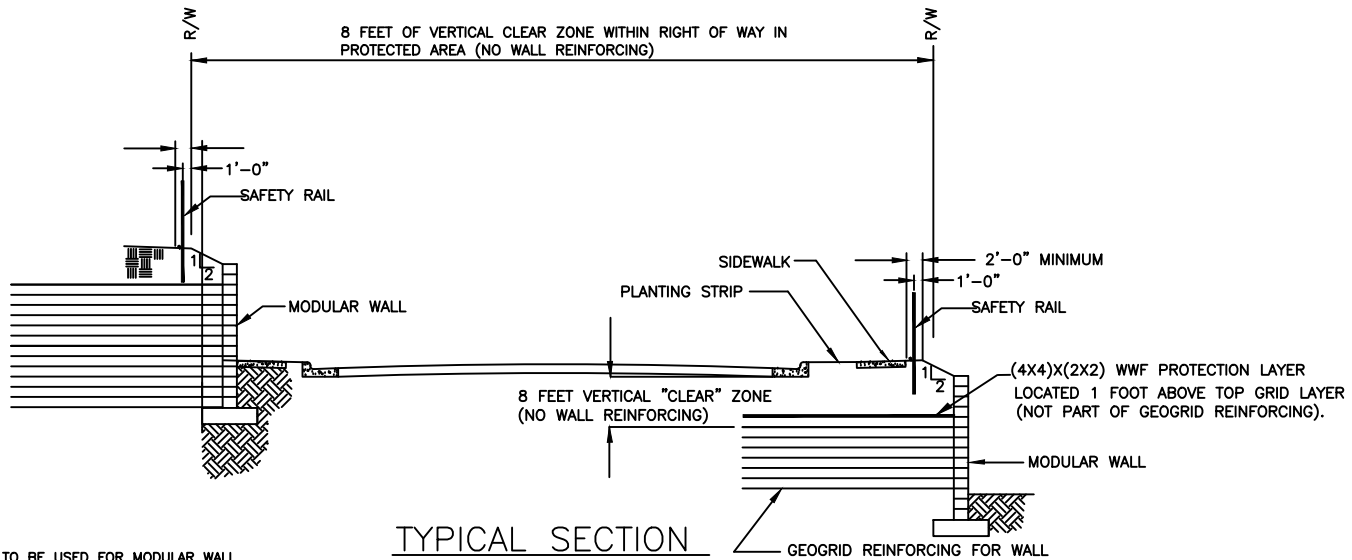
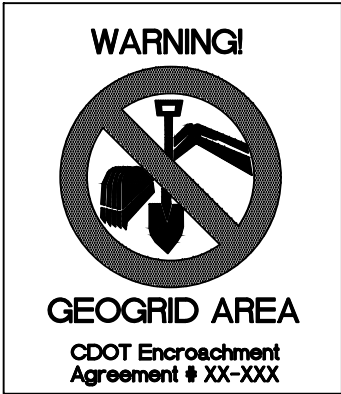

TYPICAL SECTION

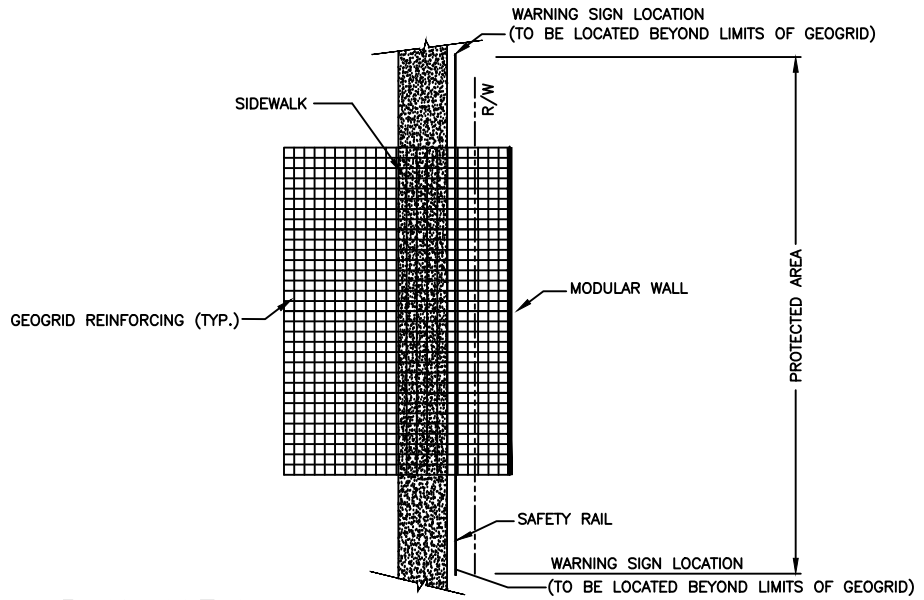

PLAN VIEW

NOT TO SCALE

WARNING SIGN
DETAIL

NOTES

1. THIS DRAWING ILLUSTRATES THE CONCEPTS TO BE USED FOR MODULAR WALL INSTALLATIONS REGARDING WARNING SIGN PLACEMENT, CLEAR SPACE REQUIREMENTS, GEOGRID PROTECTION, AND THE NEED TO OBTAIN AN ENCROACHMENT AGREEMENT PRIOR TO CONSTRUCTION. THIS DETAIL DOES NOT CONSTITUTE A STRUCTURAL DESIGN. FULL CONSTRUCTION PLANS FOR RETAINING WALLS MUST BE SEALED BY A PROFESSIONAL ENGINEER LICENSED IN NORTH CAROLINA AND SUBMITTED TO THE CITY DURING THE PLAN REVIEW PROCESS.
2. PLACEMENT OF ANY PORTION OF A MODULAR RETAINING WALL IN THE RIGHT-OF-WAY (R/W) SHALL REQUIRE AN ENCROACHMENT AGREEMENT TO BE EXECUTED WITH CDOT PRIOR TO CONSTRUCTION.
3. SAFETY RAILS SHALL EXTEND THROUGH THE PROTECTED AREA AND WARNING SIGNS SHALL BE ATTACHED TO THE SAFETY RAIL AT EACH END OF THE PROTECTED AREA.
4. ADDITIONAL MEASURE(S) MAY BE REQUIRED BY CDOT.
5. THIS DETAIL APPLIES ONLY TO STREETS MAINTAINED (OR TO-BE-MAINTAINED) BY THE CITY OF CHARLOTTE. THIS DETAIL IS NOT PERMITTED FOR USE ON NEW OR EXISTING NCDOT-MAINTAINED ROADWAYS.
6. CDOT PREFERENCES CAST-IN-PLACE REINFORCED CONCRETE WALLS WITH NO GEO-GRID OR TIEBACKS FOR WALLS IN OR NEAR THE PUBLIC RIGHT-OF-WAY.
7. CDOT PREFERENCES THAT ALL RETAINING WALLS AND APPURTENANCES BE LOCATED OUTSIDE OF THE R/W IN ORDER TO PROVIDE ADEQUATE SPACE FOR UTILITES (AERIAL AND UNDERGROUND), LANDSCAPING, SIDEWALKS, AND OTHER ITEMS.
8. GEOGRID IS NOT PERMITTED IN STORM DRAINAGE EASEMENTS OR CLT WATER EASEMENTS, NOR IN THE PROXIMITY OF STORM DRAIN PIPES, OR WATER OR SEWER UTILITY LINES.



CITY OF CHARLOTTE
LAND DEVELOPMENT STANDARDS

MODULAR RETAINING WALLS
USING GEOGRID IN THE RIGHT-OF-WAY

STD. NO.	REV.
10.39	24

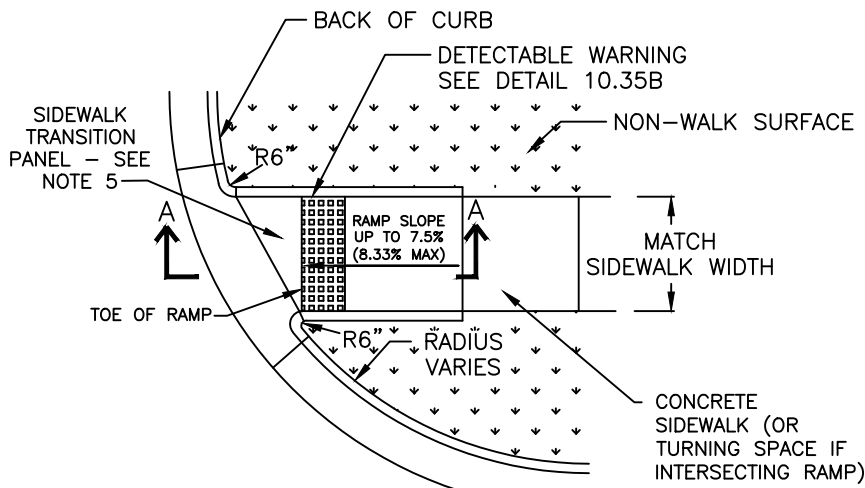

PLAN

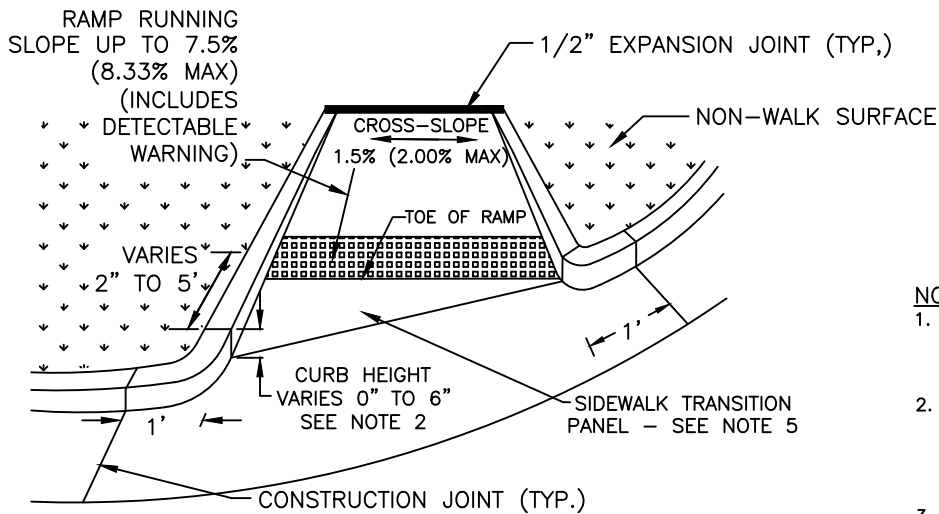

PERSPECTIVE

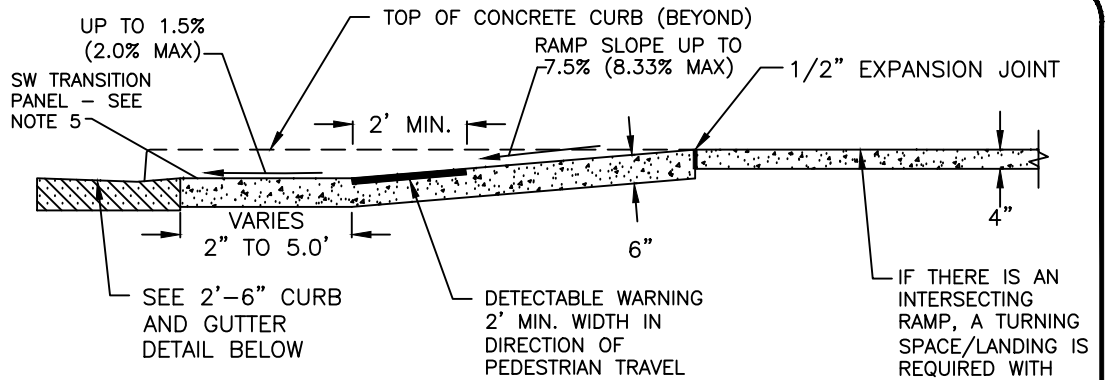

SECTION A-A

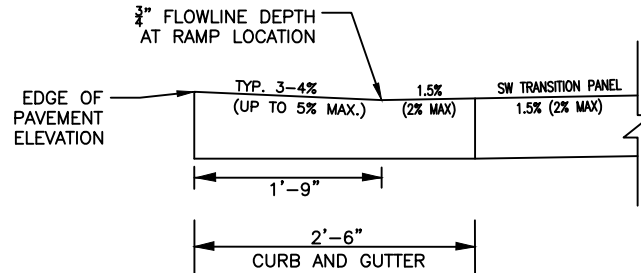

2'-6" CURB AND GUTTER DETAIL
MAXIMUM SLOPES FOR CURB AND GUTTER DEPRESSION AT DIRECTIONAL RAMPS

NOTES:

- USE THIS DETAIL ONLY UNDER THE FOLLOWING CIRCUMSTANCES:
 - 5-FOOT SIDEWALKS WITH CURB RADII OF 35 FEET OR LESS
 - 6-FOOT SIDEWALKS WITH CURB RADII OF 30 FEET OR LESS
 - 8-FOOT SIDEWALKS WITH CURB RADII OF 25 FEET OR LESS
- DIRECTIONAL RAMPS WITH RETURNED CURBS AS SHOWN MAY BE USED WHEN A PLANTING STRIP (NON-WALK SURFACE) IS PROVIDED. DO NOT USE THIS DETAIL IF THERE IS HARDSCAPE (WALKABLE SURFACE) INSTEAD OF A PLANTING STRIP. IF A WALKABLE SURFACE IS ADJACENT TO RAMP CONSTRUCT CONCRETE FLARES WITH SLOPES UP TO 10% MAX, INSTEAD OF RETURNED CURBS.
- ALL CONCRETE SHALL BE AT LEAST 3600 PSI.
- ENSURE FLUSH CONDITIONS AT RAMP TO GUTTER TRANSITION.
- SIDEWALK TRANSITION PANEL: PREFERRED DESIGN IS 1.5% (2.0% MAX) IN ALL DIRECTIONS IN FRONT OF GRADE BREAK & DRAIN TO FLOW LINE. RUNNING SLOPE OF THIS AREA MUST NOT EXCEED 2%. CROSS-SLOPE MAY MATCH STREET GRADE AT BACK OF CURB WHEN STREET GRADE >2%. TRANSITION TO 1.5% (2.0% MAX) CROSS-SLOPE AT TOE OF RAMP.

THIS DETAIL IS NOT FOR USE IN ETJ, OR ON NCDOT-MAINTAINED STREETS.

NOT TO SCALE



CITY OF CHARLOTTE
LAND DEVELOPMENT STANDARDS

DIRECTIONAL CURB RAMP
WITH SMALL/MEDIUM CURB RADII

STD. NO.	REV.
10.40A	17

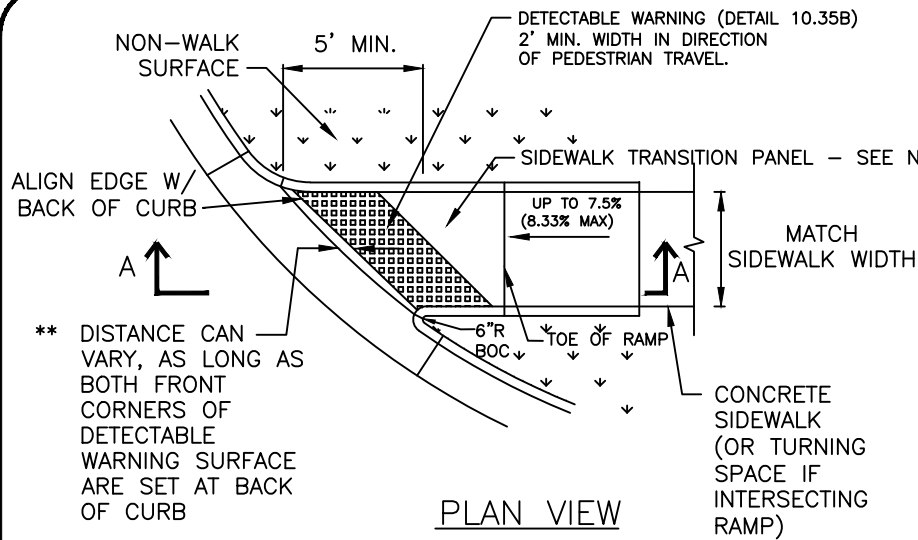

PLAN VIEW

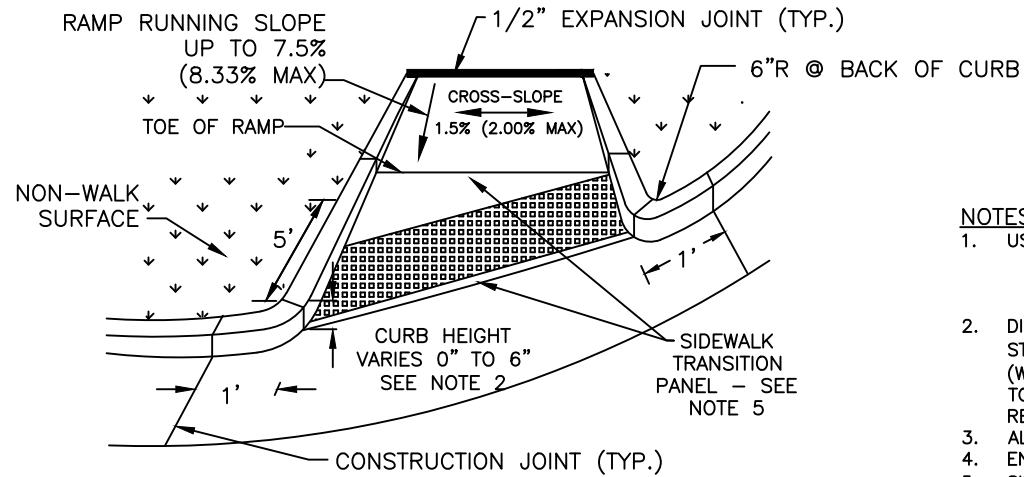

PERSPECTIVE

THIS DETAIL IS NOT FOR USE IN ETJ, OR ON NCDOT-MAINTAINED STREETS.

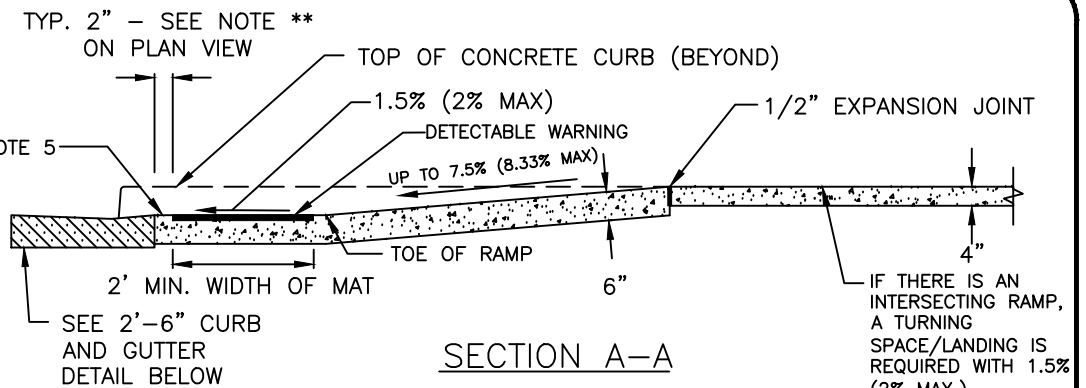

SECTION A-A

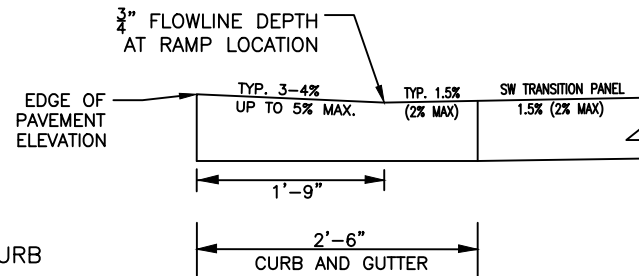

2'-6" CURB AND GUTTER DETAIL

MAXIMUM SLOPES FOR CURB AND GUTTER DEPRESSION AT DIRECTIONAL RAMPS

NOTES:

- USE THIS DETAIL ONLY UNDER THE FOLLOWING CIRCUMSTANCES:
 - 5-FOOT SIDEWALKS WITH CURB RADII GREATER THAN 35 FEET
 - 6-FOOT SIDEWALKS WITH CURB RADII GREATER THAN 30 FEET
 - 8-FOOT SIDEWALKS WITH CURB RADII GREATER THAN 25 FEET
- DIRECTIONAL RAMPS WITH RETURNED CURBS AS SHOWN MAY BE USED WHEN A PLANTING STRIP (NON-WALK SURFACE) IS PROVIDED. DO NOT USE THIS DETAIL IF THERE IS HARDSCAPE (WALKABLE SURFACE) INSTEAD OF A PLANTING STRIP. IF A WALKABLE SURFACE IS ADJACENT TO RAMP CONSTRUCT CONCRETE FLARES WITH SLOPES UP TO 10% MAX, INSTEAD OF RETURNED CURBS.
- ALL CONCRETE SHALL BE AT LEAST 3600 PSI.
- ENSURE FLUSH CONDITIONS AT RAMP TO GUTTER TRANSITION.
- SIDEWALK TRANSITION PANEL: PREFERRED 1.5% (2.0% MAX) IN ALL DIRECTIONS IN FRONT OF GRADE BREAK AND DRAIN TO FLOW LINE. RUNNING SLOPE OF THIS AREA MUST NOT EXCEED 2%. CROSS-SLOPE MAY MATCH STREET GRADE AT BACK OF CURB WHEN STREET GRADE >2%. TRANSITION TO 1.5% (2.0% MAX) CROSS-SLOPE AT TOE OF RAMP.

NOT TO SCALE



CITY OF CHARLOTTE
LAND DEVELOPMENT STANDARDS

DIRECTIONAL CURB RAMP
WITH LARGE CURB RADIUS

STD. NO.	REV.
10.40B	20

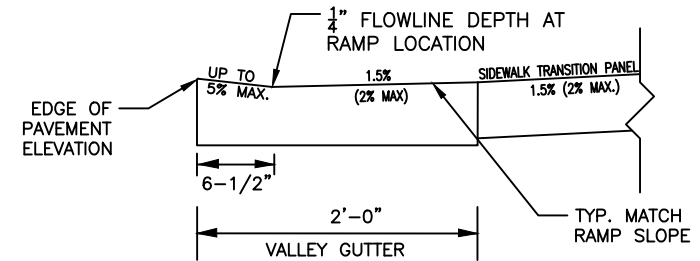
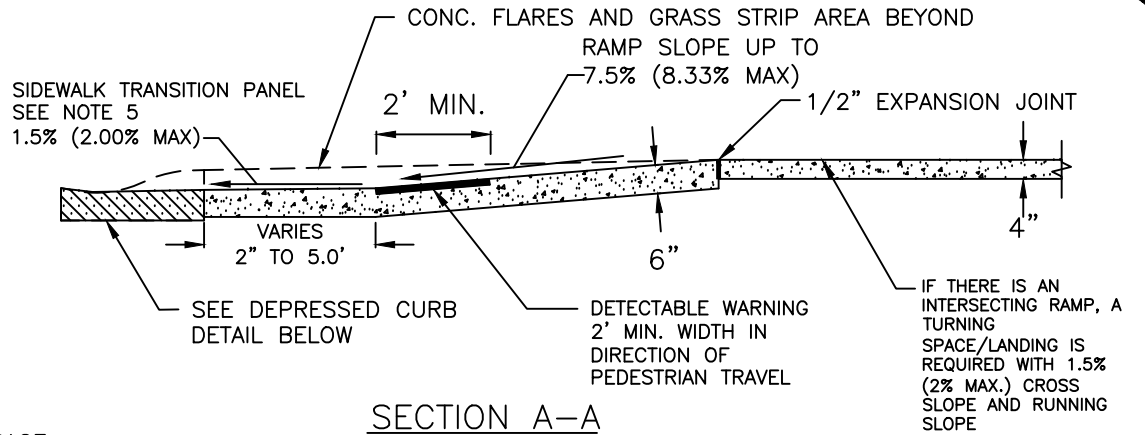
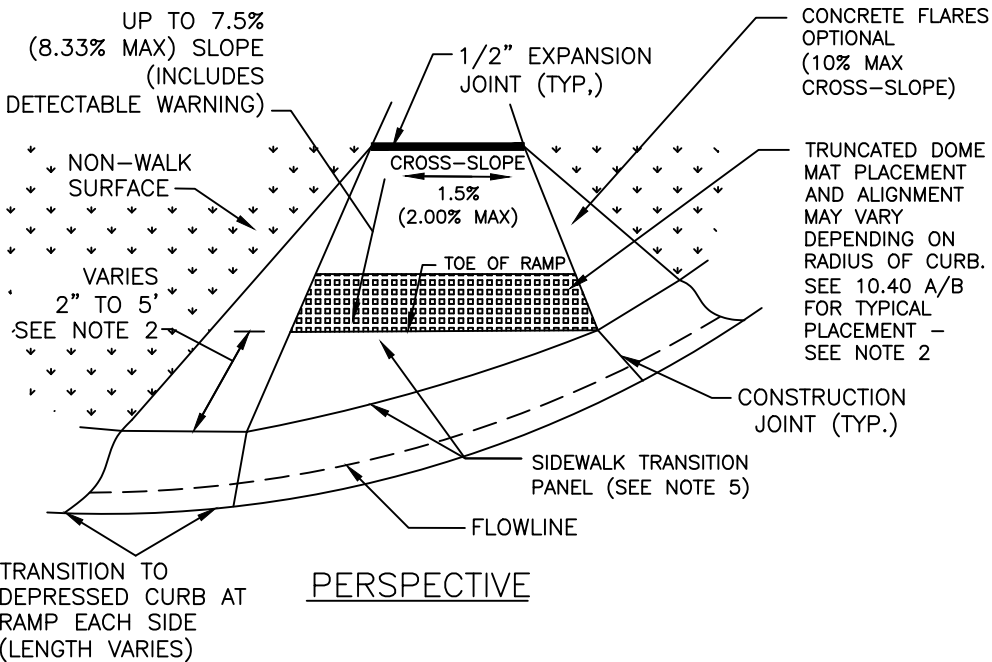
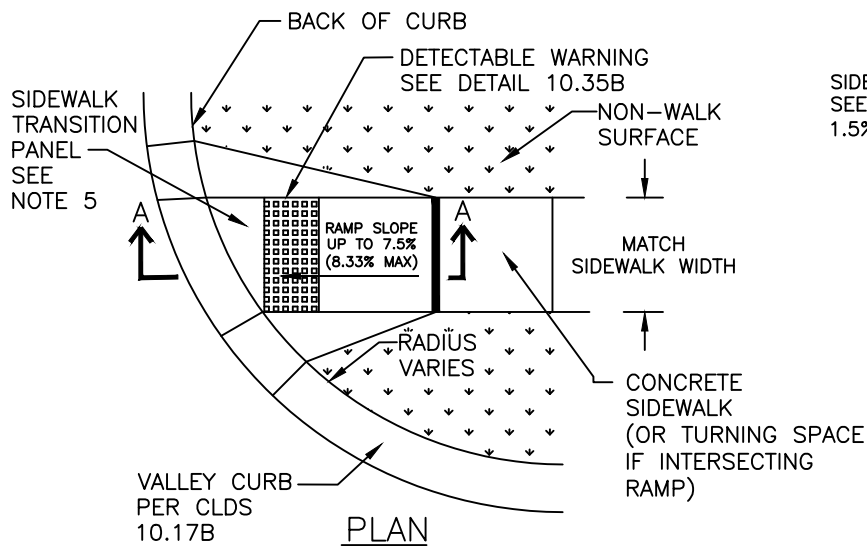

DEPRESSED CURB DETAIL
MAXIMUM SLOPES FOR CURB AND GUTTER DEPRESSION AT RAMPS

NOTES:

1. USE THIS DETAIL ONLY UNDER THE FOLLOWING CIRCUMSTANCES:
 - 5-FOOT SIDEWALKS WITH CURB RADII OF 35 FEET OR LESS
 - 6-FOOT SIDEWALKS WITH CURB RADII OF 30 FEET OR LESS
 - 8-FOOT SIDEWALKS WITH CURB RADII OF 25 FEET OR LESS
2. IF CURB RADIUS EXCEEDS THOSE LISTED ABOVE, REFER TO DETAIL 10.40B FOR DETECTABLE WARNING SURFACE MAT PLACEMENT.
3. ALL CONCRETE SHALL BE AT LEAST 3600 PSI.
4. ENSURE FLUSH CONDITIONS AT RAMP TO GUTTER TRANSITION.
5. SIDEWALK TRANSITION PANEL: PREFERRED 1.5% (2.0% MAX) IN ALL DIRECTIONS IN FRONT OF GRADE BREAK AND DRAIN TO FLOW LINE. RUNNING SLOPE OF THIS AREA MUST NOT EXCEED 2%. CROSS-SLOPE MAY MATCH STREET GRADE AT BACK OF CURB WHEN STREET GRADE >2%. TRANSITION TO 1.5% (2.0% MAX) CROSS-SLOPE AT TOE OF RAMP.

NOT TO SCALE



CITY OF CHARLOTTE
LAND DEVELOPMENT STANDARDS
INCLUDES CHARLOTTE ETJ

DIRECTIONAL CURB RAMP
WITH VALLEY GUTTER

STD. NO.	REV.
10.40C	17

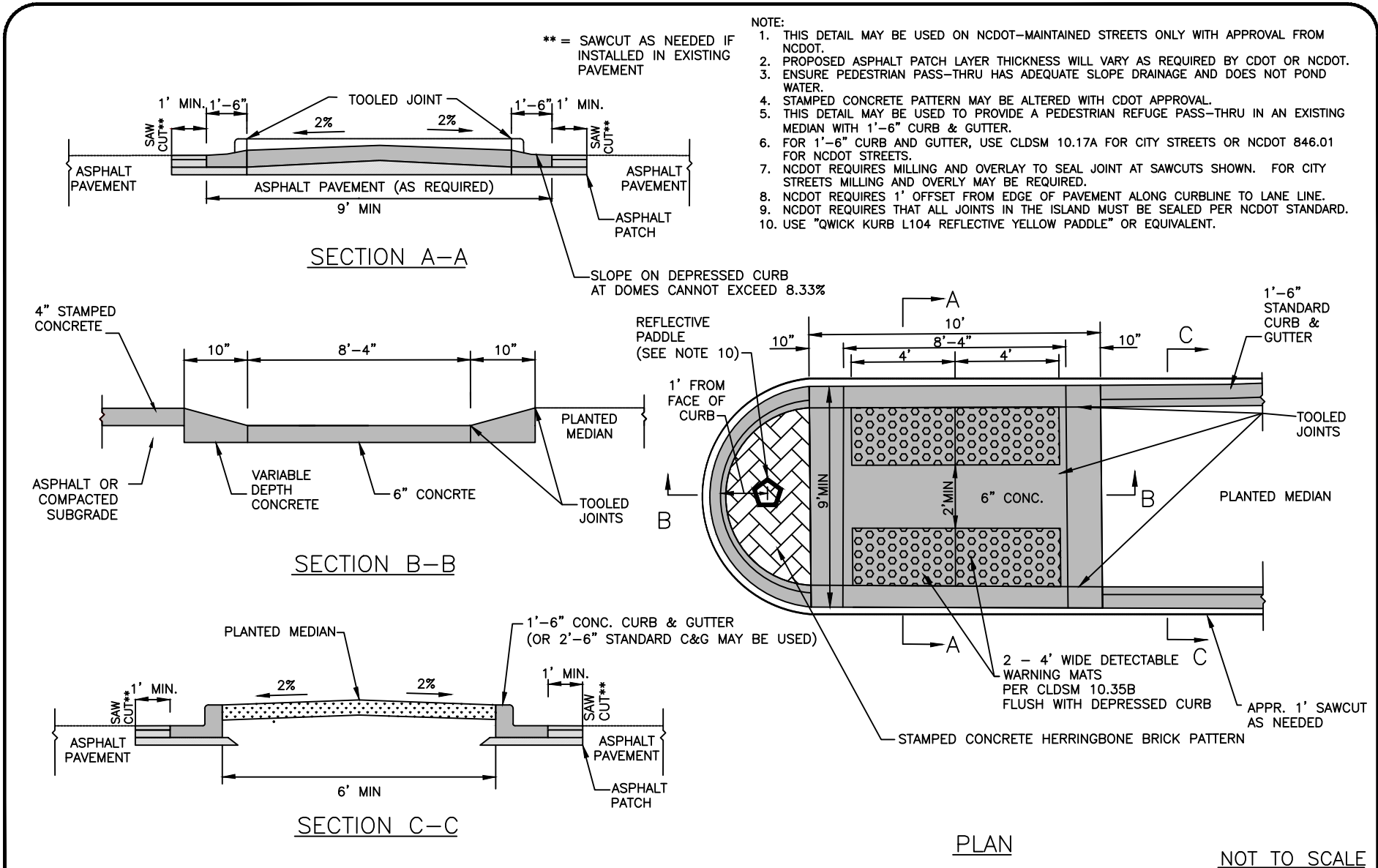

CITY OF CHARLOTTE
 LAND DEVELOPMENT STANDARDS
 INCLUDES CHARLOTTE ETJ

PEDESTRIAN REFUGE
 (WITH 1'-6" CURB & GUTTER)

STD. NO.	REV.
10.41A	23

** = SAWCUT AS
NEEDED IF
INSTALLED IN
EXISTING
PAVEMENT

NOTES:

1. THIS DETAIL IS APPROVED FOR CITY MAINTAINED STREETS ONLY.
2. PROPOSED ASPHALT PATCH LAYER THICKNESS WILL VARY AS REQUIRED BY CDOT.
3. ENSURE PEDESTRIAN PASS-THRU HAS ADEQUATE SLOPE DRAINAGE AND DOES NOT POND WATER.
4. STAMPED CONCRETE PATTERN MAY BE ALTERED WITH CDOT APPROVAL.
5. THIS DETAIL MAY BE USED TO PROVIDE A PEDESTRIAN REFUGE PASS-THRU IN AN EXISTING MEDIAN WITH VERTICAL CURB.
6. MILLING AND OVERLAY MAY BE REQUIRED TO SEAL JOINTS AT SAWCUT LOCATIONS.
7. USE "QWICK KURB L104 REFLECTIVE YELLOW PADDLE" OR EQUIVALENT.

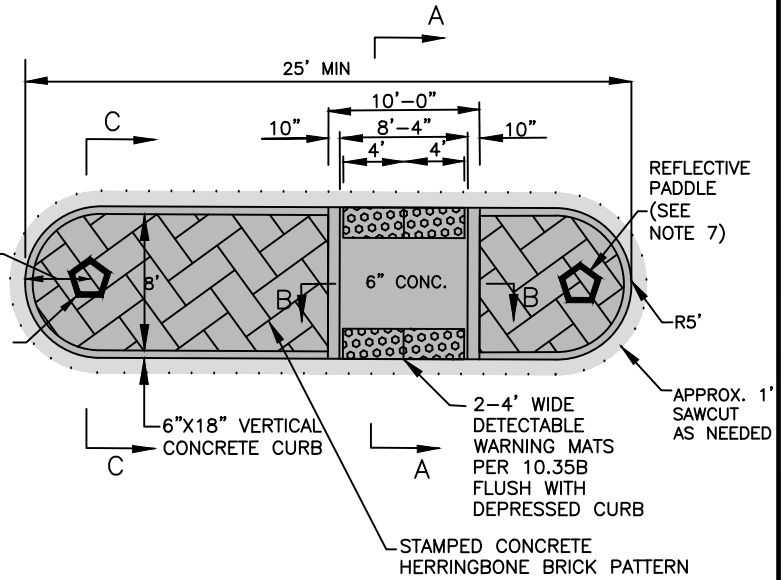
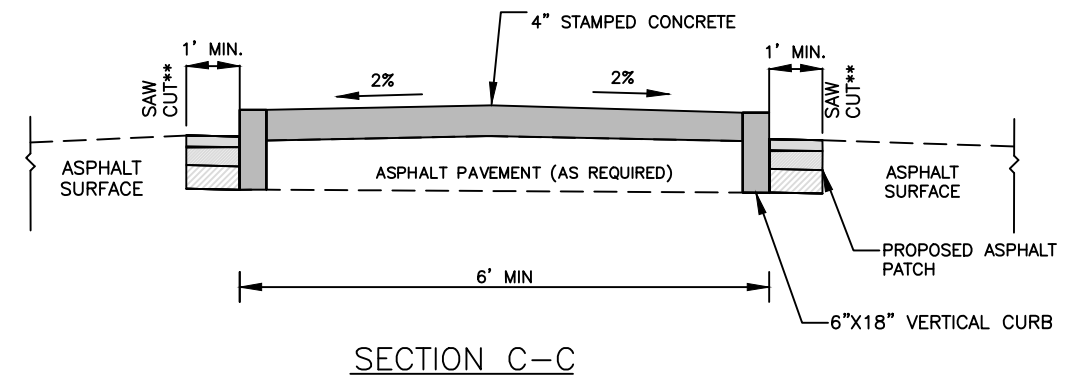
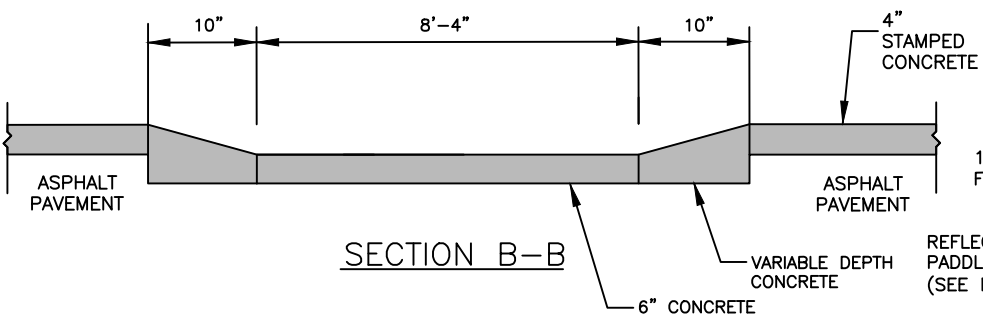
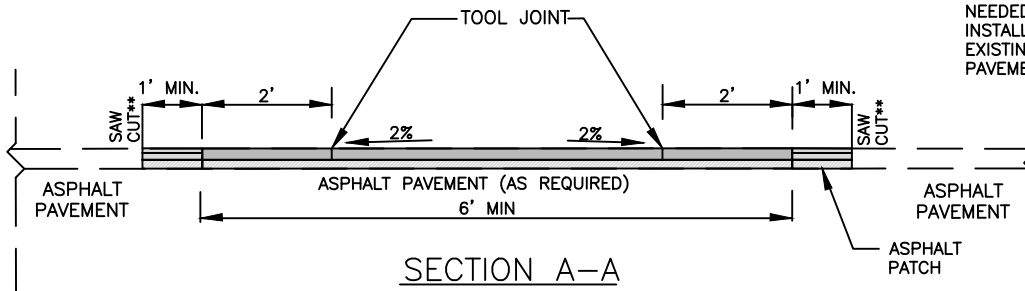

NOT TO SCALE



CITY OF CHARLOTTE
LAND DEVELOPMENT STANDARDS

PEDESTRIAN REFUGE
(WITH VERTICAL CURB)

STD. NO.	REV.
10.41B	23

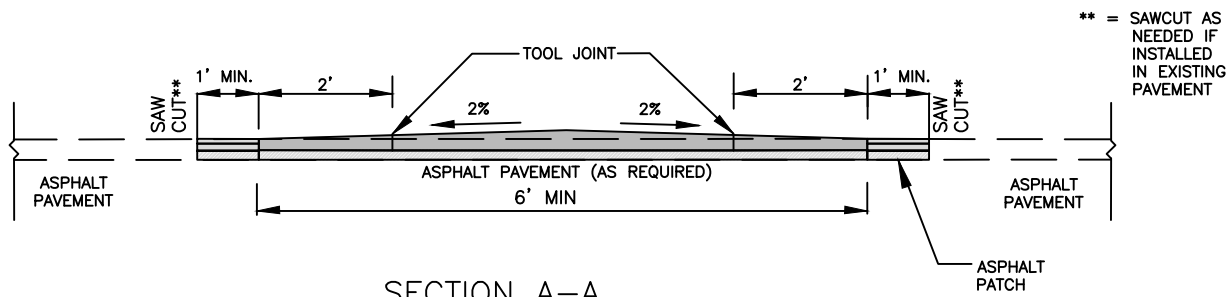

SECTION A-A

** = SAWCUT AS NEEDED IF INSTALLED IN EXISTING PAVEMENT

NOTES:

1. THIS DETAIL CAN ONLY BE USED WITH APPROVAL FROM CDOT OR NCDOT. 1'-6" CURB & GUTTER OR VERTICAL CURB PEDESTRIAN REFUGE DETAILS ARE PREFERRED.
2. PROPOSED ASPHALT PATCH LAYER THICKNESS WILL VARY AS REQUIRED BY CDOT OR NCDOT.
3. ENSURE PEDESTRIAN PASS-THRU HAS ADEQUATE SLOPE DRAINAGE AND DOES NOT POND WATER.
4. NCDOT REQUIRES MILLING AND OVERLAY TO SEAL JOINT AT SAWCUTS SHOWN. FOR CITY STREETS MILLING AND OVERLAY MAY BE REQUIRED.
5. NCDOT REQUIRES 1' OFFSET FROM EDGE OF PAVEMENT ALONG CURBLINE TO LANE LINE.
6. NCDOT REQUIRES THAT ALL JOINTS BE SEALED PER NCDOT STANDARD.
7. USE "QWICK KURB L104 REFLECTIVE YELLOW PADDLE" OR EQUIVALENT.

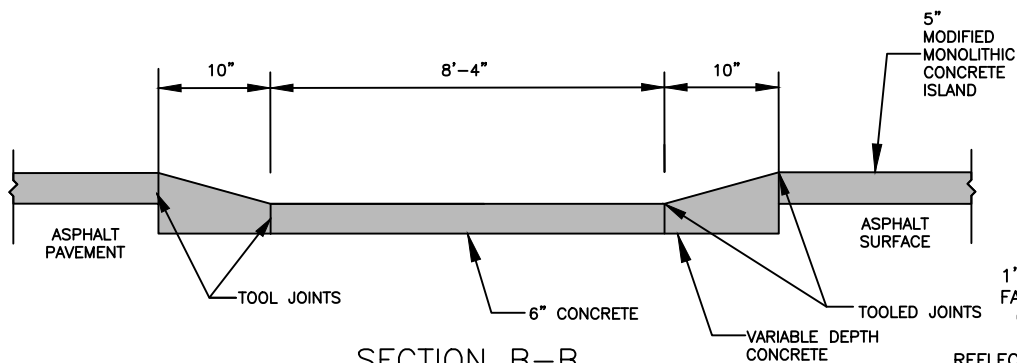

SECTION B-B

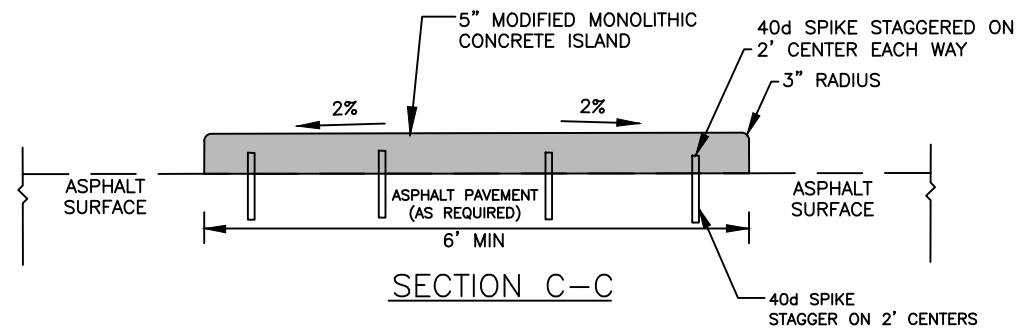

SECTION C-C

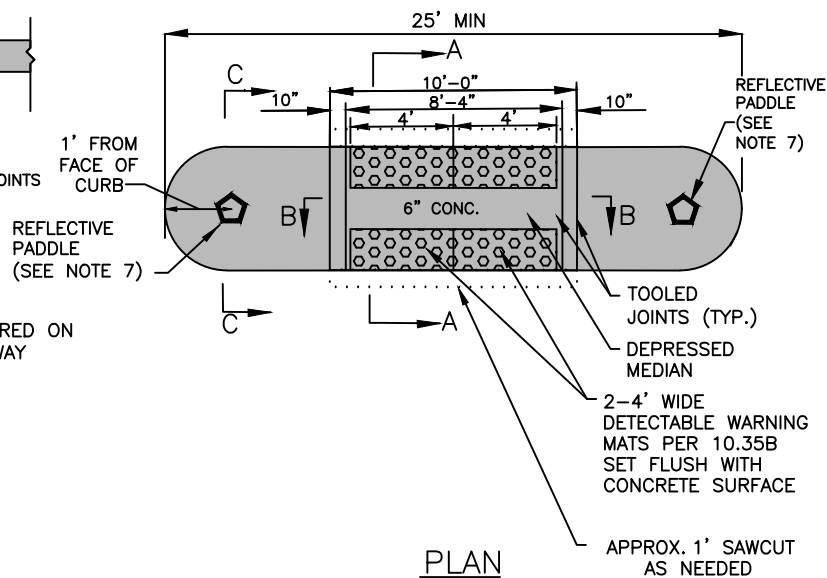

PLAN

NOT TO SCALE



CITY OF CHARLOTTE
LAND DEVELOPMENT STANDARDS
INCLUDES CHARLOTTE ETJ

PEDESTRIAN REFUGE
(MODIFIED MONOLITHIC)

STD. NO.	REV.
10.41C	23

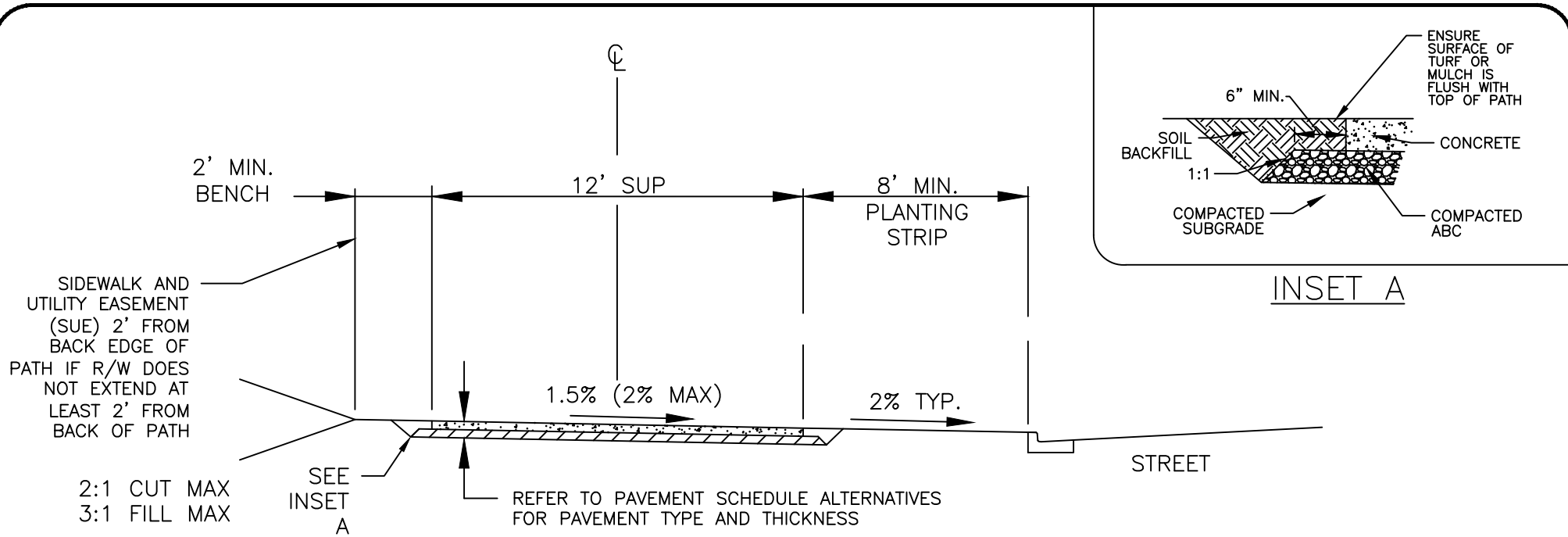

NOTES:

1. AT INTERSECTIONS WITH STREETS OR DRIVEWAYS, RAMP WIDTH MUST MATCH SHARED-USE PATH WIDTH.
2. IF SHARED-USE PATHS ARE NOT PART OF OR PARALLEL TO A ROADWAY, THE PAVEMENT SCHEDULE ALT 1 SHALL BE USED.
3. CONTRACTOR MUST SEAL ALL JOINTS. SEAL MUST BE NON-SHRINKING AND FLUSH WITH FINISHED GRADE OF THE CONCRETE PATH.
4. ALL CONCRETE SHALL BE AT LEAST 3600 PSI COMPRESSIVE STRENGTH.
5. JOINTS MUST BE SAWCUT A MINIMUM OF 1/4 DEPTH OF CONCRETE DEPTH, BUT NO MORE THAN 1/2 OF CONCRETE DEPTH.
 - TRANSVERSE JOINTS MUST BE SAWCUT EVERY 6 FEET WHEN PAVEMENT SCHEDULE ALT 1 OR ALT 3 ARE USED.
 - TRANSVERSE JOINTS MUST BE SAWCUT EVERY 10 FEET FOR PAVEMENT SCHEDULE ALT 2.
 - CONSTRUCTION JOINTS MUST BE EVERY 40 FEET.
6. UTILIZE THIS DETAIL FOR OFF-STREET PATHS. INCLUDE 2' MINIMUM WIDTH BENCH AT 1.5% CROSS-SLOPE PRIOR TO THE START OF CUT/FILL SLOPE, APPLY MAXIMUM CUT/FILL SLOPES, AND 2' SUE REQUIREMENTS TO BOTH SIDES OF PATH.

PAVEMENT SCHEDULE ALTERNATIVES

ALTERNATIVE	DESCRIPTION
ALT 1 (PREFERRED)	6" CONCRETE
	3" COMPACTED AGGREGATE BASE COURSE (ABC)
	COMPACTED SUBGRADE
ALT 2	6" CONCRETE
	COMPACTED SUBGRADE
ALT 3	4" CONCRETE
	3" COMPACTED AGGREGATE BASE COURSE (ABC)
	COMPACTED SUBGRADE

NOT TO SCALE



CITY OF CHARLOTTE
LAND DEVELOPMENT STANDARDS
 INCLUDES CHARLOTTE ETJ

SHARED-USE PATH (SUP) AND
 OFF-STREET PATH

STD. NO.	REV.
10.42	23

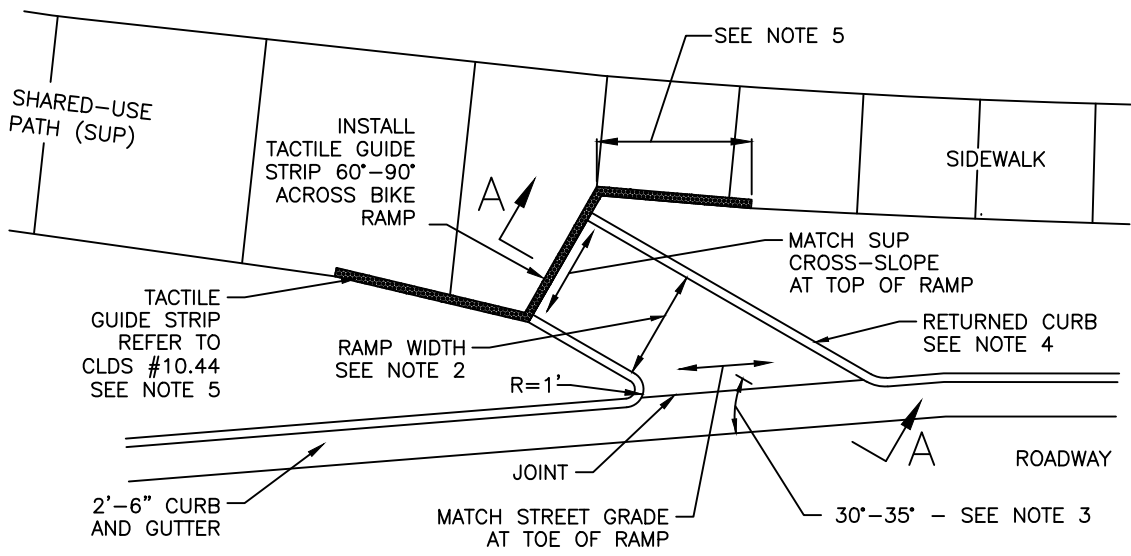

NOTES:

1. BIKE RAMP ALLOWS BICYCLE RIDERS TO TRANSITION FROM AN ON-STREET BICYCLE FACILITY TO/FROM AN OFF-STREET FACILITY.
2. FOR ONE-WAY FACILITIES, BIKE RAMP WIDTH IS 6'. FOR TWO-WAY BIKE FACILITIES, BIKE RAMP WIDTH SHALL MATCH THE WIDTH OF THE SHARED-USE PATH, WITH A MINIMUM WIDTH OF 10'.
3. BIKE RAMP SHALL BE PLACED AT A MINIMUM OF 30' AND A MAXIMUM OF 35' TO THE ROADWAY. BIKE RAMPS SHOULD BE PLACED ENTIRELY WITHIN THE PLANTING STRIP BETWEEN THE SHARED-USE PATH/SIDEWALK AND THE ROADWAY.
4. ON CITY-MAINTAINED STREETS, INSTALL A RETURNED VERTICAL CURB ALONG THE SIDES OF THE BIKE RAMP AS SHOWN, TAPER TO 0" DEPTH AT MUP. ON NCDOT-MAINTAINED STREETS, INSTALL CONCRETE FLARES ALONG THE SIDES OF THE BIKE RAMP.
5. INSTALL 2 TACTILE GUIDE STRIP MODULES ALONG PEDESTRIAN FACILITY.
6. FOLLOW "NCHRP 672 ROUNDABOUTS: AN INFORMATION GUIDE" (CURRENT EDITION) FOR BIKE RAMP PLACEMENT AT ROUNDABOUTS.

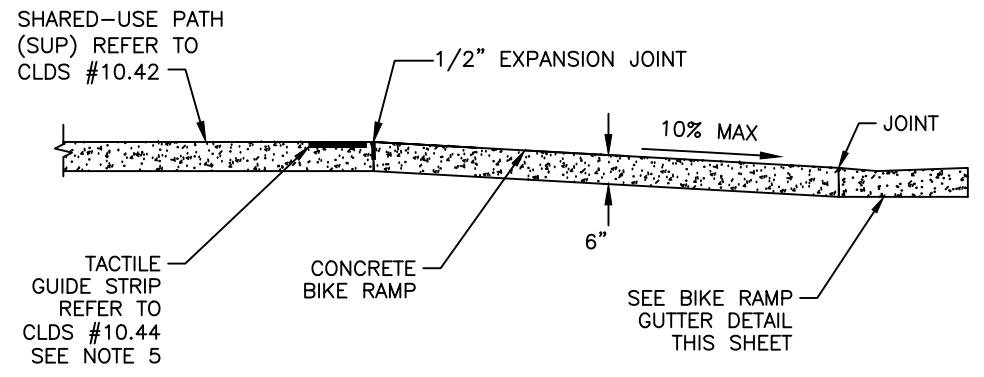

SECTION A-A

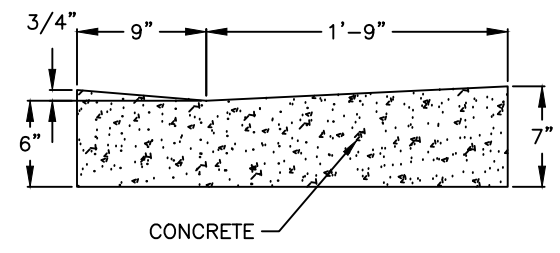

BIKE RAMP GUTTER DETAIL

NOT TO SCALE



**CITY OF CHARLOTTE
LAND DEVELOPMENT STANDARDS**
INCLUDES CHARLOTTE ETJ

BIKE RAMP AT SHARED USE PATH

STD. NO.	REV.
10.43	23

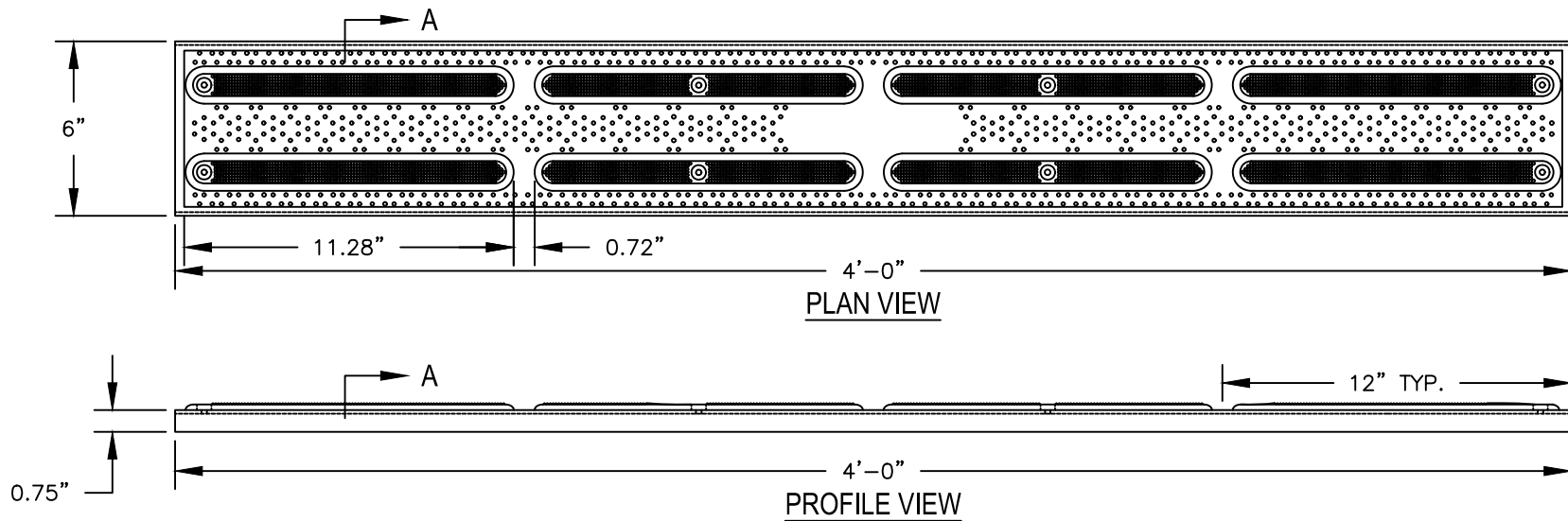

NOTES:

1. SUBMIT TACTILE GUIDE STRIP SHOP DRAWINGS TO CITY FOR REVIEW AND APPROVAL PRIOR TO INSTALLATION.
2. INSTALL TACTILE GUIDE STRIP PER MANUFACTURER'S DIRECTIONS.
3. THE COLOR OF THE TACTILE GUIDE STRIP SHALL MEET PROWAG REQUIREMENTS FOR CONTRAST WITH THE SURROUNDING PAVEMENT/SIDEWALK. FEDERAL YELLOW #33538 PROVIDES THE REQUIRED LEVEL OF CONTRAST AND SHALL BE USED, UNLESS:
 - 3.A. THE PAVEMENT/SIDEWALK IS A COLOR THAT DOES NOT PROVIDE SUFFICIENT CONTRAST WITH FEDERAL YELLOW #33538, OR
 - 3.B. AN ADOPTED STREETSCAPE, PEDSCAPE, OR SIMILAR PLAN PRESCRIBES A COLOR PALETTE TO USE (E.G., TRYON STREET MALL)
4. SUBMIT SHOP DRAWINGS OF ANY COLOR OTHER THAN FEDERAL YELLOW #33538 TO THE CITY FOR REVIEW AND APPROVAL BY CDOT PRIOR TO INSTALLATION. COMPLIANCE WITH THE COLOR-CONTRAST REQUIREMENTS OF PROWAG SHALL SUPERSEDE ANY CONFLICTING PROVISION IN A PRESCRIBED COLOR PALETTE.
5. MATERIAL SHALL BE FIBERGLASS-REINFORCED VITRIFIED POLYMER COMPOSITE.
6. IF CUTTING OF A TILE IS NECESSARY, CUT ONLY IN WHOLE ONE-FOOT INCREMENTS.

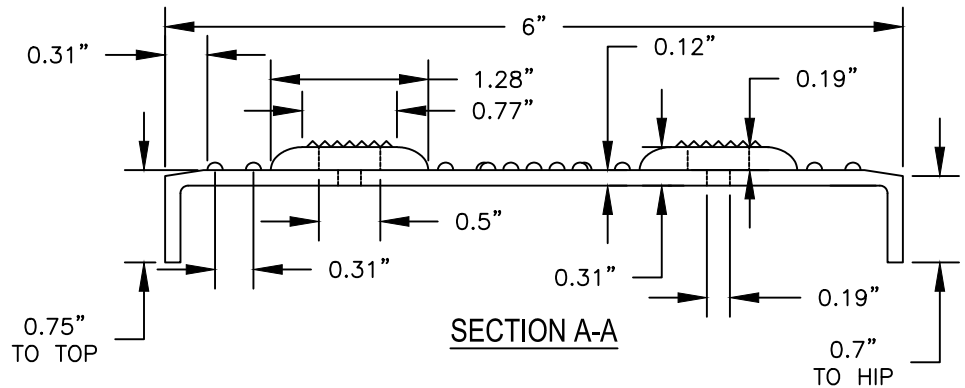

NOT TO SCALE



CITY OF CHARLOTTE
 LAND DEVELOPMENT STANDARDS
 INCLUDES CHARLOTTE ETJ

TACTILE GUIDE STRIP

STD. NO.	REV.
10.44	21

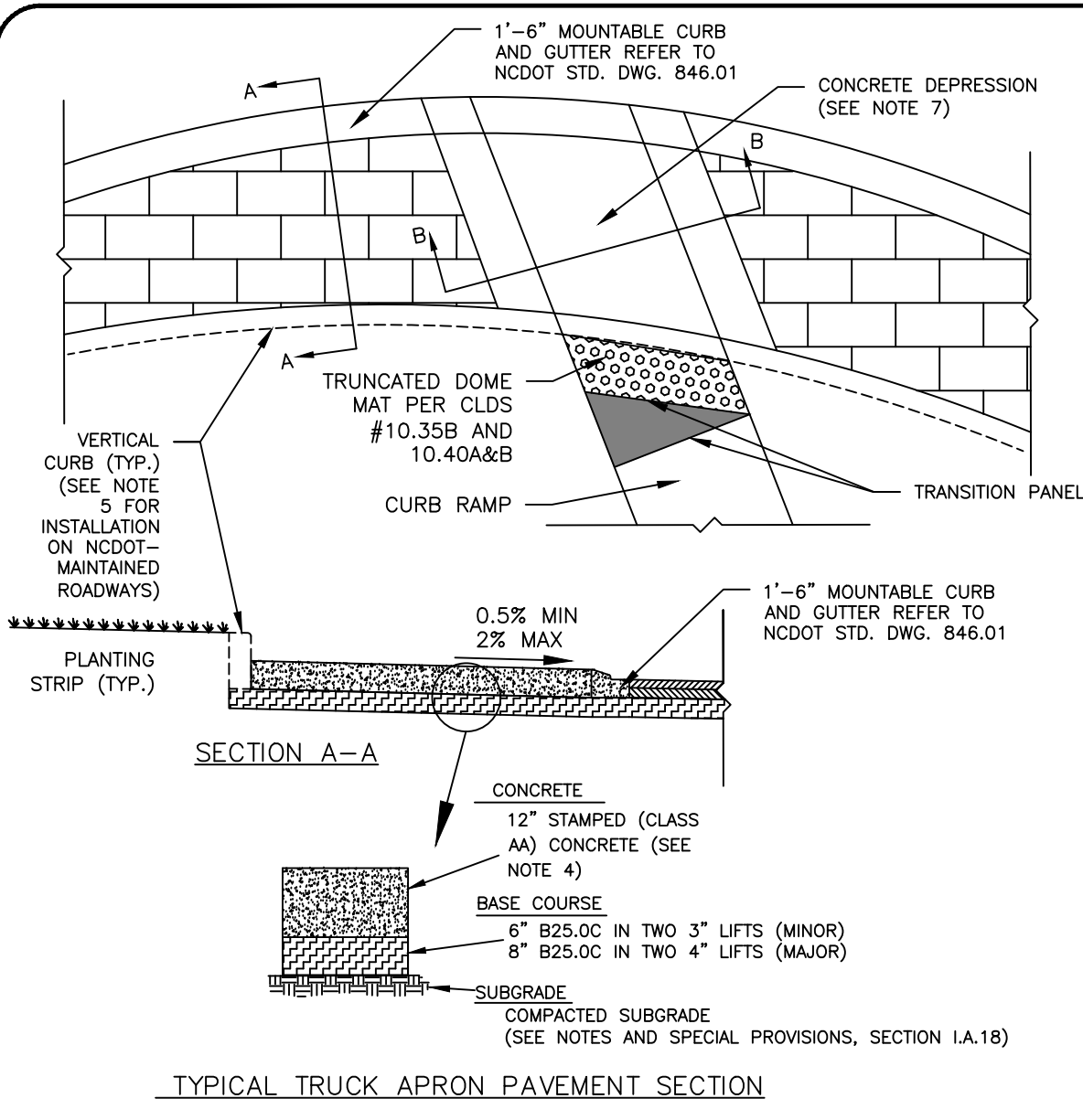

NOTES:

1. THIS DETAIL CAN BE USED ON NCDOT AND CITY OF CHARLOTTE STREETS WITH PRIOR NCDOT AND CDOT APPROVAL.
2. WIDTH OF THE TRUCK APRON SHALL ACCOMMODATE A DESIGN VEHICLE AS DETERMINED BY CDOT/NCDOT.
3. TRUCK APRON SHALL BE CONCRETE AND STAMPED WITH A BRICK PATTERN.
4. CONCRETE SHALL BE NATURALLY COLORED.
5. ON NCDOT-MAINTAINED FACILITIES, INSTALL 1'-6" SPILL CURB AND GUTTER BEHIND THE TRUCK APRON INSTEAD OF VERTICAL CURB AS SHOWN. THE GUTTER SPILL SLOPE MUST MATCH THE SLOPE OF THE ADJACENT TRUCK APRON. ON CITY-MAINTAINED STREETS, INSTALL VERTICAL CURB AS ILLUSTRATED.
6. ENSURE POSITIVE DRAINAGE THROUGHOUT THE APRON. AVOID STORM DRAINAGE STRUCTURES WITHIN THE MOUNTABLE CURB AND GUTTER.
7. PROVIDE FLUSH TRANSITIONS THROUGHOUT CONCRETE DEPRESSION AREA AND ENSURE RUNNING SLOPE AND CROSS SLOPE OF 2% MAX. FOR ALTERATIONS OF EXISTING CROSSINGS, CROSS SLOPE MAY MATCH ROAD GRADE.
8. AT SIGNALIZED INTERSECTIONS, ACCESSIBLE PEDESTRIAN SIGNALS (APS) WILL BE REQUIRED FOR ALL CROSSINGS TO & FROM CORNERS WITH TRUCK APRONS. ENGINEER TO COORDINATE WITH CDOT IMPLEMENTATION ON PLACEMENT, APS FEATURES, AND OPERATIONS.

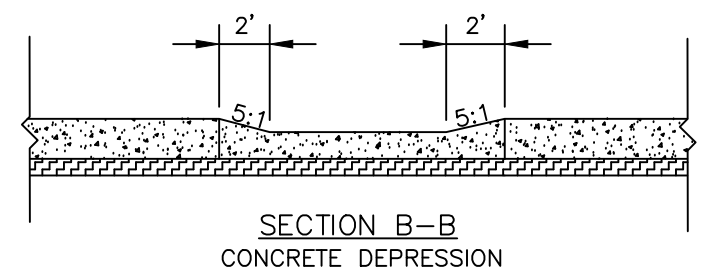

NOT TO SCALE



CITY OF CHARLOTTE
LAND DEVELOPMENT STANDARDS
INCLUDES CHARLOTTE ETJ

TRUCK APRON AT INTERSECTION

STD. NO.	REV.
10.45A	25

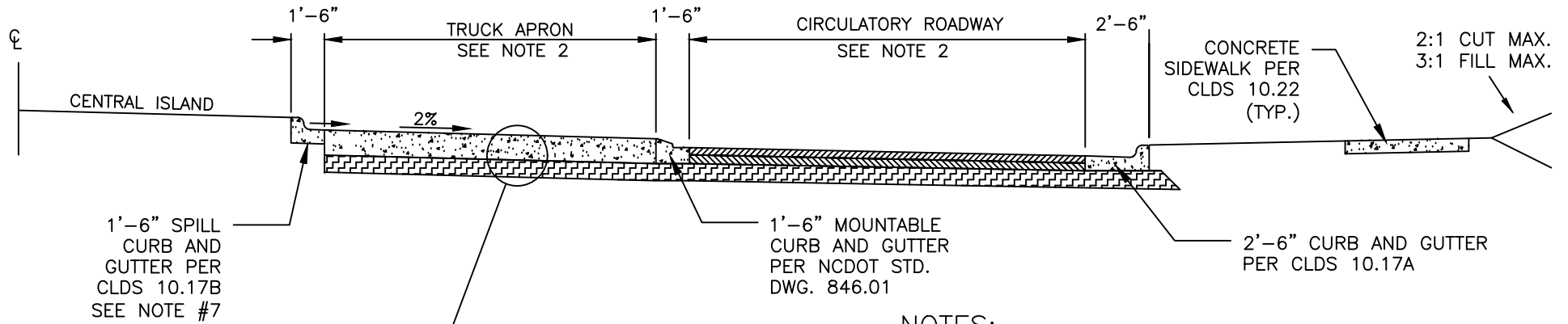

1'-6" SPILL CURB AND GUTTER PER CLDS 10.17B SEE NOTE #7

TRUCK APRON SEE NOTE 2

CIRCULATORY ROADWAY SEE NOTE 2

CONCRETE SIDEWALK PER CLDS 10.22 (TYP.)

2:1 CUT MAX. 3:1 FILL MAX.

1'-6" MOUNTABLE CURB AND GUTTER PER NCDOT STD. DWG. 846.01

2'-6" CURB AND GUTTER PER CLDS 10.17A

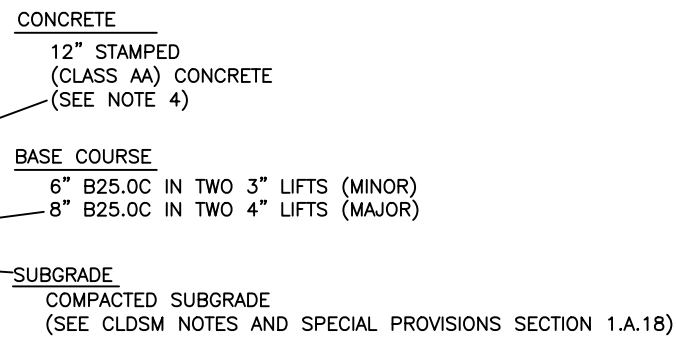

NOTES:

1. THIS DETAIL CAN BE USED AT ROUNDABOUTS ON ALL NCDOT AND CITY OF CHARLOTTE STREETS WITH PRIOR NCDOT AND CITY APPROVAL.
2. WIDTH OF TRUCK APRON AND CIRCULATORY ROADWAY TRAVEL LANE SHALL BE IN ACCORDANCE TO CURRENT "NCHRP 672 ROUNDABOUTS: AN INFORMATION GUIDE" (CURRENT EDITION).
3. TRUCK APRON SHALL BE CONCRETE AND STAMPED WITH A BRICK PATTERN.
4. CONCRETE SHALL BE NATURALLY COLORED.
6. ENSURE POSITIVE DRAINAGE THROUGHOUT THE APRON. AVOID STORM DRAINAGE STRUCTURES WITHIN THE MOUNTABLE CURB AND GUTTER.
7. INSTALL "SPILL" CURB AND GUTTER BETWEEN THE TRUCK APRON AND THE CENTER OF THE ROUNDABOUT. THE GUTTER SPILL SLOPE MUST MATCH THE SLOPE OF THE ADJACENT TRUCK APRON.

TYPICAL TRUCK APRON PAVEMENT SECTION

NOT TO SCALE



CITY OF CHARLOTTE
 LAND DEVELOPMENT STANDARDS
 INCLUDES CHARLOTTE ETJ

TRUCK APRON AT ROUNDABOUT

STD. NO.	REV.
10.45B	25

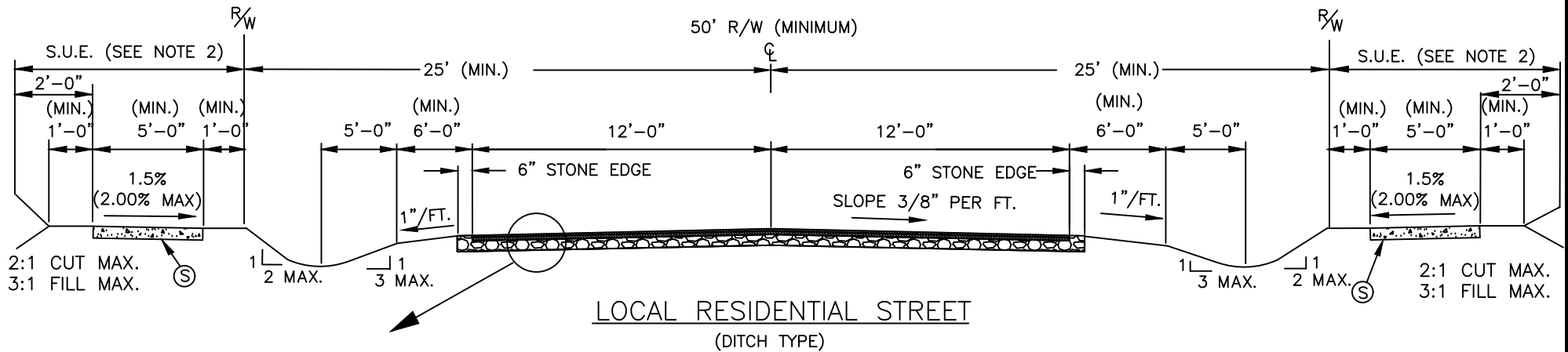

TACK COAT
(SEE SECTION 1.E.4)

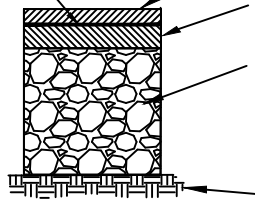

SURFACE COURSE

1" S9.5B
FINAL LIFT TO BE APPLIED UPON MEETING ONE OF THE FOLLOWING CONDITIONS:
1) 75% DEVELOPMENT OCCUPANCY,
2) 1 YEAR FROM INTERMEDIATE COURSE PLACEMENT,
3) FOR ETJ STREETS, FINAL 1" MAY BE PLACED WHEN APPROVED BY NCDOT.

INTERMEDIATE COURSE

1-1/2" S9.5C OR S9.5B

BASE COURSE

8" COMPACTED AGGREGATE BASE COURSE, OR 4" BCBC TYPE B25.0C
SHOULD ENTIRE DEVELOPMENT HAVE A CBR OF 6 OR GREATER, THEN AN
ALTERNATIVE BASE COURSE PAVEMENT DESIGN MAY BE SUBMITTED TO THE
CITY FOR APPROVAL.

SUBGRADE

COMPACTED SUBGRADE (SEE CLDS SPECIFICATIONS AND SPECIAL PROVISIONS SECTION 1.A.18)

TYPICAL PAVEMENT SECTION

NOTES:

1. SIDEWALK SHALL BE ON BOTH SIDES OF STREET AND LOCATED ON LOT SIDE OF DITCH.
2. SIDEWALK OR SHARED-USE PATH (SUP) LOCATED OUTSIDE OF STREET RIGHT OF WAY SHALL BE LOCATED IN A PERMANENT SIDEWALK AND UTILITY EASEMENT (SUE) EXTENDING 2' BEHIND BACK OF SIDEWALK OR SUP.
3. APPROVAL BY THE CITY IS REQUIRED PRIOR TO USING DITCH TYPE SECTION.

KEY

⊙ = 4" CONCRETE SIDEWALK

NOT TO SCALE



CITY OF CHARLOTTE
LAND DEVELOPMENT STANDARDS
INCLUDES CHARLOTTE ETJ

LOCAL RESIDENTIAL
TYPICAL DITCH TYPE STREET SECTION

STD. NO.	REV.
11.02	23

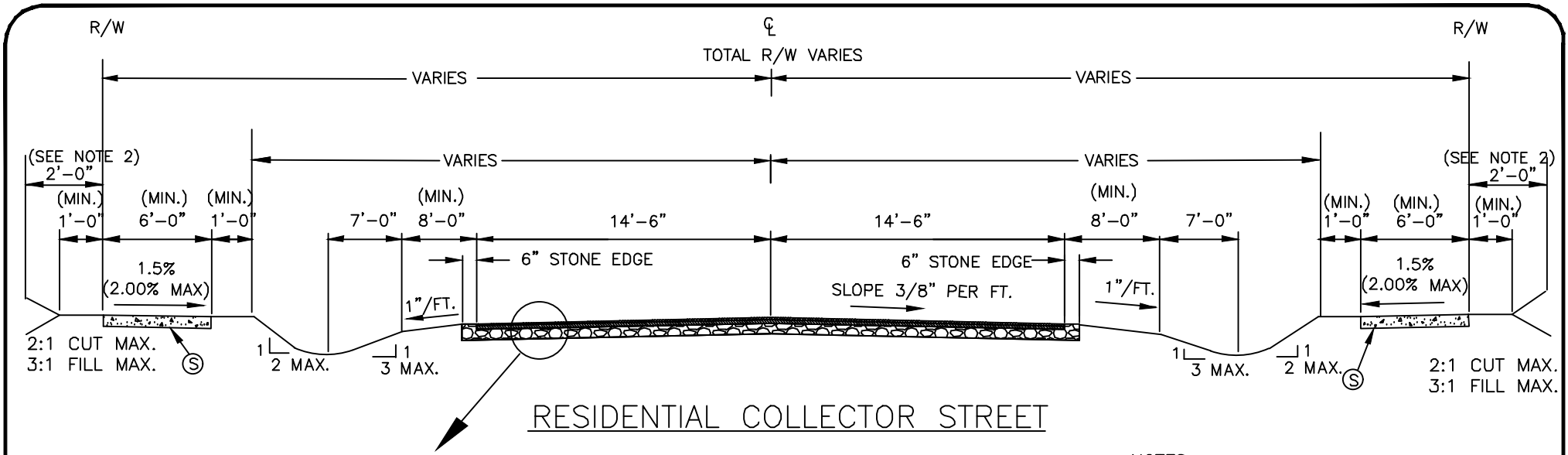

RESIDENTIAL COLLECTOR STREET

SURFACE COURSE
1" S9.5B

FINAL LIFT TO BE APPLIED UPON MEETING ONE OF THE FOLLOWING CONDITIONS:
 1) 75% DEVELOPMENT OCCUPANCY,
 2) 1 YEAR FROM INTERMEDIATE COURSE PLACEMENT,
 3) FOR ETJ STREETS, FINAL 1" MAY BE PLACED WHEN APPROVED BY NCDOT.

INTERMEDIATE COURSE
1 1/2" S9.5C OR S9.5B

BASE COURSE
 8" COMPACTED AGGREGATE BASE COURSE, OR 4" BCBC TYPE B25.0C
 SHOULD ENTIRE DEVELOPMENT HAVE A CBR OF 6 OR GREATER, THEN AN
 ALTERNATIVE BASE COURSE PAVEMENT DESIGN MAY BE SUBMITTED TO THE
 CITY FOR APPROVAL.

SUBGRADE
 COMPACTED SUBGRADE (SEE CLDS SPECIFICATIONS AND SPECIAL PROVISIONS SECTION 1.A.18)

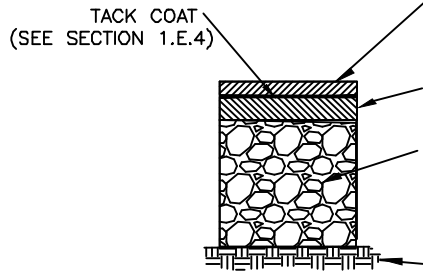

TYPICAL MINIMUM PAVEMENT SECTION
(SEE NOTE 4.)

NOTES:

1. SIDEWALK SHALL BE ON BOTH SIDES OF STREET AND LOCATED ON LOT SIDE OF DITCH.
2. 2' BUFFER CAN BE SUE OR ADDITIONAL R/W
3. APPROVAL BY THE CITY IS REQUIRED PRIOR TO USING ANY DITCH TYPE SECTION.
4. AN ALTERNATIVE PAVEMENT DESIGN MAY BE REQUIRED BY CDOT/NCDOT BASED ON SPECIFIC TRAFFIC PARAMETERS.

KEY

 (S) 4" CONCRETE SIDEWALK

NOT TO SCALE



CITY OF CHARLOTTE
LAND DEVELOPMENT STANDARDS
 INCLUDES CHARLOTTE ETJ

RESIDENTIAL COLLECTOR STREET DITCH TYPE
 STREET TYPICAL SECTION (6' SIDEWALK)

STD. NO.	REV.
11.07A	23

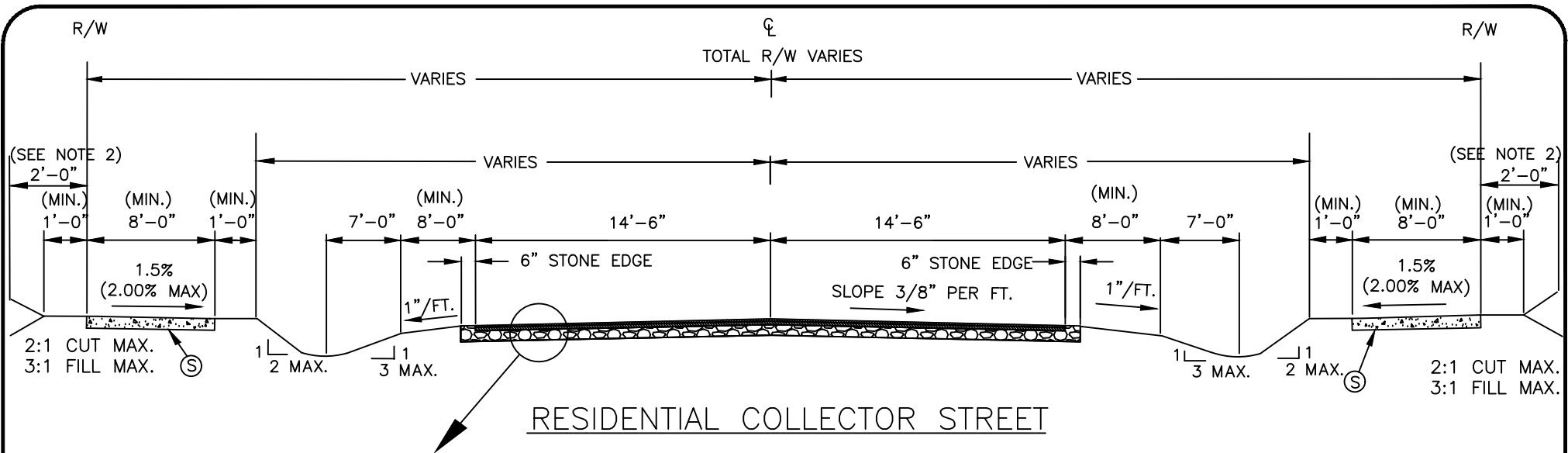

RESIDENTIAL COLLECTOR STREET

SURFACE COURSE
1" S9.5B

FINAL LIFT TO BE APPLIED UPON MEETING ONE OF THE FOLLOWING CONDITIONS:
 1) 75% DEVELOPMENT OCCUPANCY,
 2) 1 YEAR FROM INTERMEDIATE COURSE PLACEMENT,
 3) FOR ETJ STREETS, FINAL 1" MAY BE PLACED WHEN APPROVED BY NCDOT.

INTERMEDIATE COURSE
1 1/2" S9.5C OR S9.5B

BASE COURSE
8" COMPACTED AGGREGATE BASE COURSE, OR 4" BCBC TYPE B25.0C
 SHOULD ENTIRE DEVELOPMENT HAVE A CBR OF 6 OR GREATER, THEN AN
 ALTERNATIVE BASE COURSE PAVEMENT DESIGN MAY BE SUBMITTED TO THE
 CITY FOR APPROVAL.

SUBGRADE
COMPACTED SUBGRADE (SEE CLDS SPECIFICATIONS AND SPECIAL PROVISIONS SECTION 1.A.18)

TACK COAT
(SEE SECTION 1.E.4)

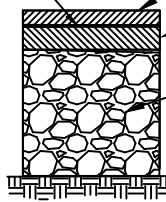

TYPICAL MINIMUM PAVEMENT SECTION
(SEE NOTE 4.)

NOTES:

1. SIDEWALK SHALL BE ON BOTH SIDES OF STREET AND LOCATED ON LOT SIDE OF DITCH.
2. 2' BUFFER CAN BE SIDEWALK & UTILITY EASEMENT (SUE) OR ADDITIONAL R/W.
3. APPROVAL BY THE CITY IS REQUIRED PRIOR TO USING DITCH TYPE SECTION.
4. AN ALTERNATIVE PAVEMENT DESIGN MAY BE REQUIRED BY CDOT/NCDOT BASED ON SPECIFIC TRAFFIC PARAMETERS.

KEY

Ⓢ 4" CONCRETE SIDEWALK

NOT TO SCALE



CITY OF CHARLOTTE
 LAND DEVELOPMENT STANDARDS
 INCLUDES CHARLOTTE ETJ

RESIDENTIAL COLLECTOR STREET DITCH TYPE
 STREET TYPICAL SECTION (8' SIDEWALK)

STD. NO.	REV.
11.07B	23

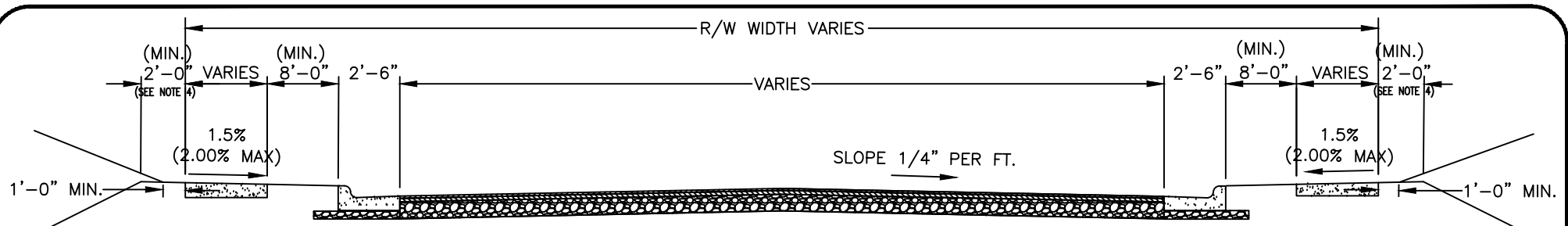

ARTERIAL (3 LANES OR LESS)

2:1 CUT MAX.
3:1 FILL MAX.

2:1 CUT MAX.
3:1 FILL MAX.

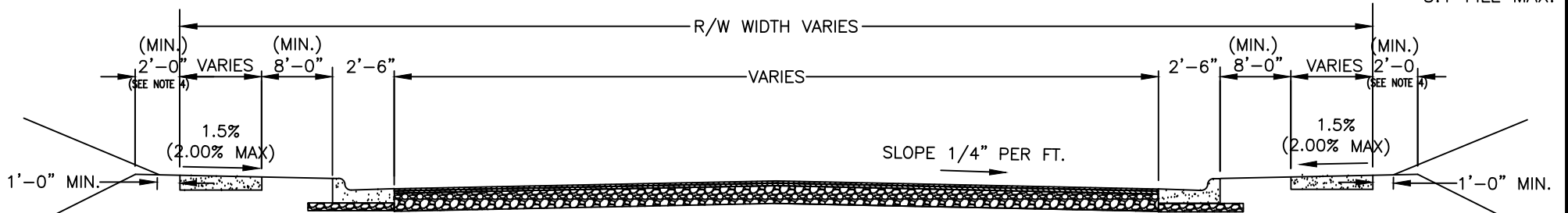

ARTERIAL (4 LANES OR MORE)

2:1 CUT MAX.
3:1 FILL MAX.

2:1 CUT MAX.
3:1 FILL MAX.

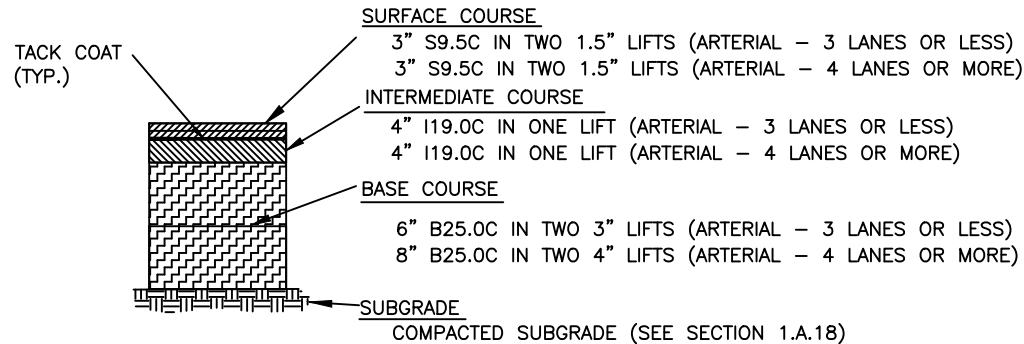

TYPICAL MINIMUM PAVEMENT SECTION
(SEE NOTE 3.)

NOTES:

1. SIDEWALKS SHALL BE PROVIDED IN ACCORDANCE WITH THE APPLICABLE ORDINANCE(S).
2. DITCH TYPE STREET IS TO BE USED ONLY WHEN APPROVED BY CITY.
3. AN ALTERNATIVE PAVEMENT DESIGN MAY BE REQUIRED BY CDOT/NCDOT BASED ON SPECIFIC TRAFFIC PARAMETERS.
4. 2' BUFFER CAN BE SUE OR ADDITIONAL R/W

NOT TO SCALE



CITY OF CHARLOTTE
 LAND DEVELOPMENT STANDARDS
 INCLUDES CHARLOTTE ETJ

ARTERIAL STREET TYPICAL SECTIONS

STD. NO.	REV.
11.09	23

NOTES:

1. DETAILS SHOWN SHALL BE CONSTRUCTED IN ACCORDANCE WITH CITY STANDARDS.
2. DITCH TYPE STREET REQUIRES APPROVAL OF CITY.
3. MINIMUM CURB RADIUS ON INTERIOR DRIVES AND PARKING AREAS IS 10'
4. THIS DETAIL IS NOT TO BE USED TO MEET INTERNAL/EXTERNAL CONNECTIVITY REQUIREMENTS OF THE SUBDIVISION ORDINANCE AND ZONING ORDINANCE.

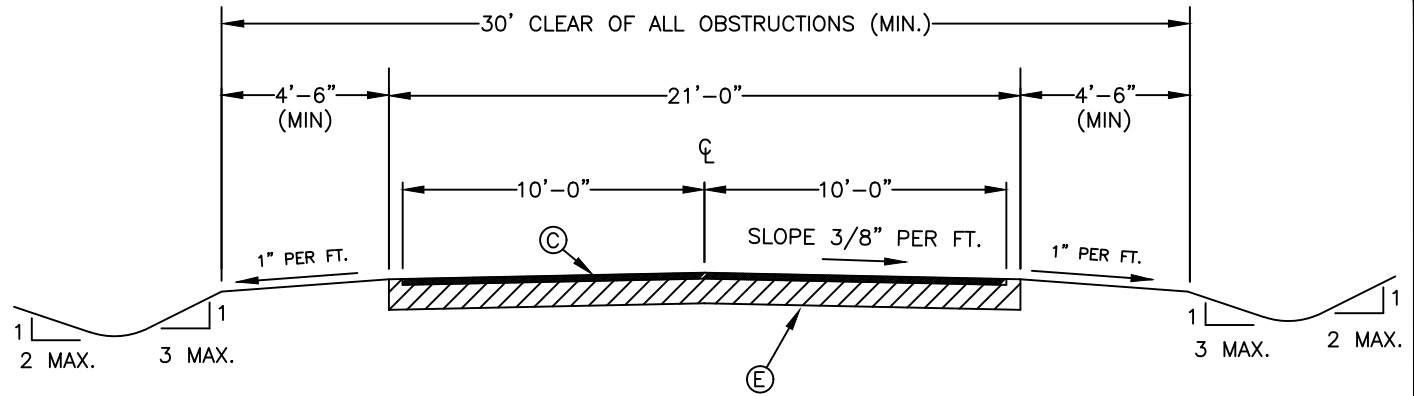

DITCH TYPE

GUIDELINES FOR PRIVATE STREET DESIGN:

1. INTERNAL STREET ALIGNMENT:
 MAXIMUM GRADE: 10%
 MINIMUM VERTICAL CURVE "K" VALUES: 10/20 (CREST/SAG)
 MINIMUM HORIZONTAL CURVE CENTERLINE RADIUS: 50 FT.
2. INTERSECTION WITH PUBLIC STREET:
 SAME AS FOR PUBLIC STREET. SEE GENERAL NOTES, SECTION I.B.2.

NOTE: VARIATIONS ON THESE GUIDELINES WILL BE REVIEWED ON A CASE BY CASE BASIS BY CITY STAFF.

PAVEMENT SCHEDULE

- (C) 1.5" BITUMINOUS CONCRETE SURFACE COURSE, TYPE S9.5B
- (E) 6" COMPACTED AGGREGATE BASE COURSE OR 4" BITUMINOUS CONCRETE BASE COURSE, TYPE B25.0C
- (R) CURB AND GUTTER (REFERENCE 10.17A AND B)

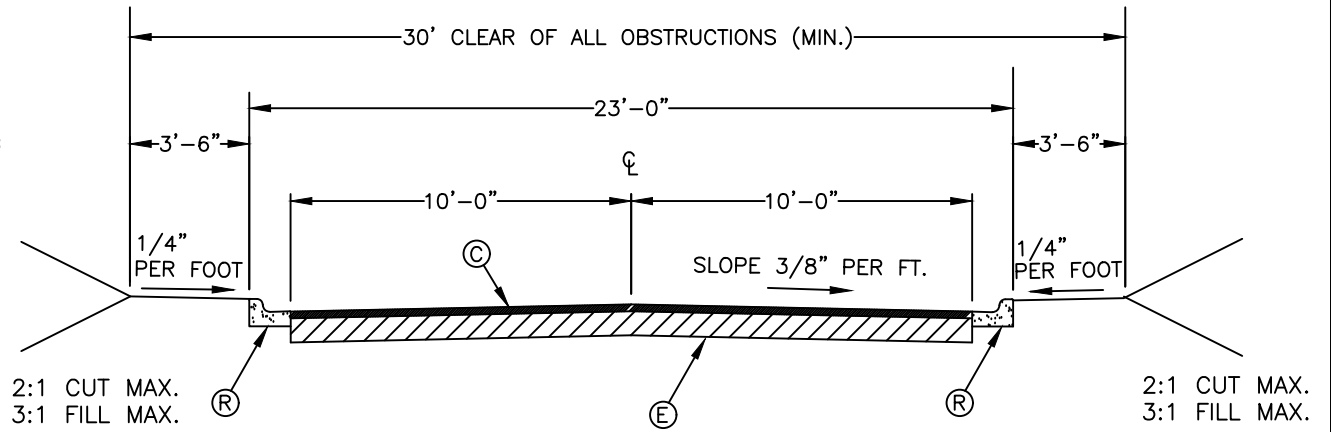

CURB AND GUTTER

NOT TO SCALE



CITY OF CHARLOTTE
 LAND DEVELOPMENT STANDARDS
 INCLUDES CHARLOTTE ETJ

PRIVATE STREET TYPICAL SECTIONS

STD. NO.	REV.
11.13	23

NOTES:

1. CURB RETURN RADIUS DIMENSIONS AT INTERSECTIONS MAY VARY DEPENDING ON MEDIAN WIDTH AND WILL BE REVIEWED ON A CASE BY CASE BASIS.
2. FOR ADDITIONAL LANES ADD 10'(MINIMUM) OF PAVEMENT PER LANE.
3. 2'-0" VALLEY GUTTER MAY BE USED WITH APPROVAL OF THE CITY.
4. MONOLITHIC CONCRETE MEDIANS WITH BEVELED EDGES AND MINIMUM WIDTH OF 4 FEET CAN BE USED IN LIEU OF LANDSCAPE MEDIANS.

GUIDELINES FOR PRIVATE STREET DESIGN:

1. INTERNAL STREET ALIGNMENT:
 MAXIMUM GRADE: 10%
 MINIMUM VERTICAL CURVE "K" VALUES: 10/20 (CREST/SAG)
 MINIMUM HORIZONTAL CURVE CENTERLINE RADIUS: 50 FT.
2. INTERSECTION WITH PUBLIC STREET:
 SAME AS FOR PUBLIC STREET. SEE CLDS SPECIFICATIONS AND SPECIAL PROVISIONS SECTION I.B.2.

NOTE: VARIATIONS ON THESE GUIDELINES WILL BE REVIEWED ON A CASE BY CASE BASIS BY CITY STAFF.

PAVEMENT SCHEDULE

- Ⓒ 1.5" BITUMINOUS CONCRETE SURFACE COURSE, TYPE S9.5B
- Ⓔ 6" COMPACTED AGGREGATE BASE COURSE OR 4" BITUMINOUS CONCRETE BASE COURSE, TYPE B25.0C
- Ⓓ CURB AND GUTTER (REFERENCE 10.17A & B).
- Ⓖ 1'-6" MOUNTABLE CURB

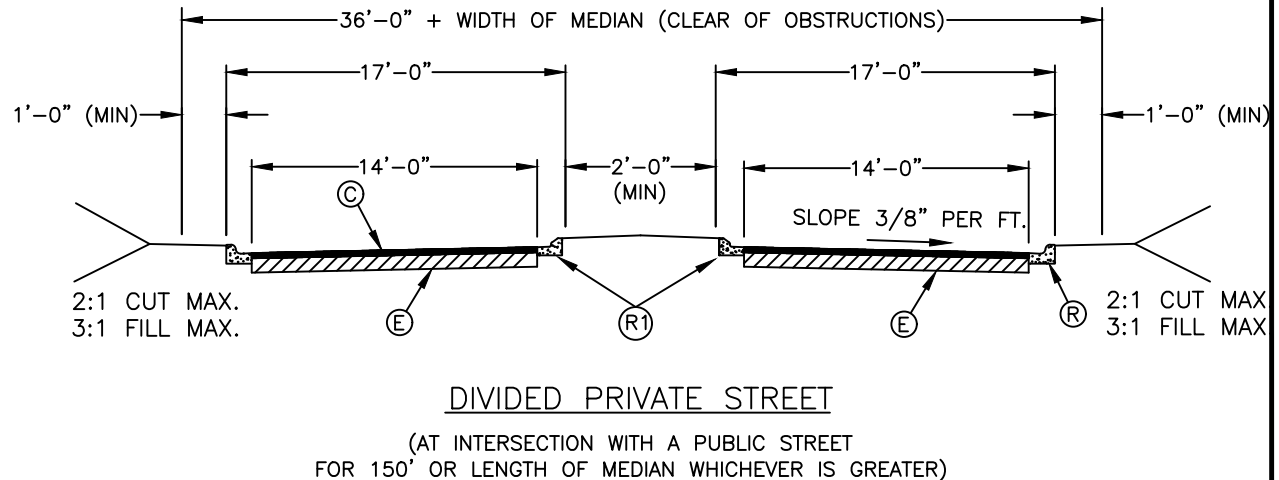
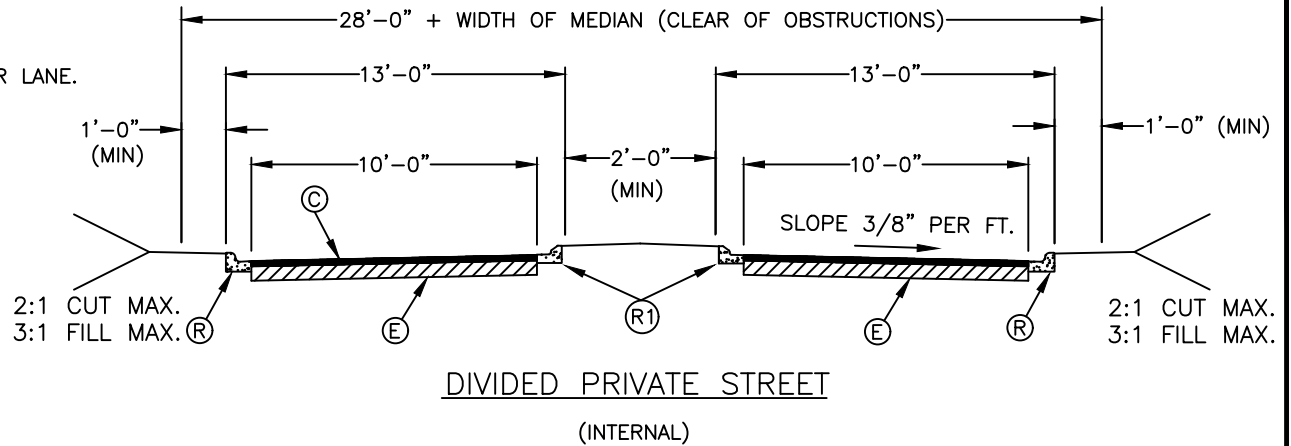

NOT TO SCALE



**CITY OF CHARLOTTE
 LAND DEVELOPMENT STANDARDS**
 INCLUDES CHARLOTTE ETJ

**DIVIDED PRIVATE STREET
 TYPICAL SECTIONS**

STD. NO.	REV.
11.14	23

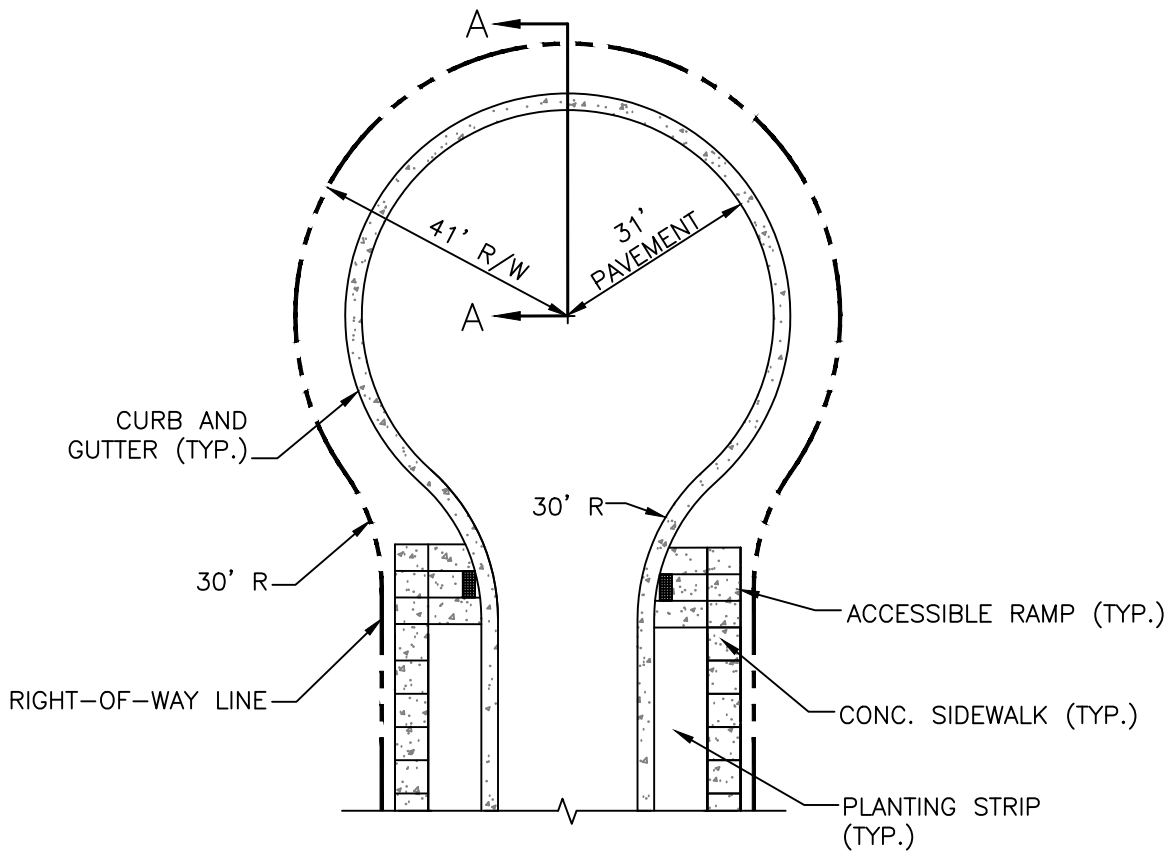

STANDARD CUL-DE-SAC

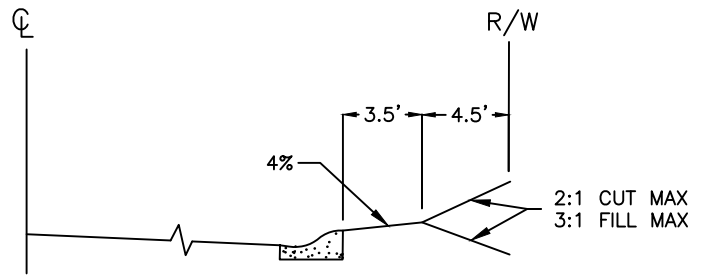

SECTION A-A

APPLICABLE WHEN NO SIDEWALK PRESENT.
PLEASE NOTE: DRIVEWAY STANDARD
MAX. SLOPES AND BREAKOVERS APPLY

NOTES:

1. ALTERNATIVE CUL-DE-SAC DESIGNS, INCLUDING ISLANDS SHALL BE SUBMITTED TO THE CITY FOR REVIEW AND APPROVAL.
2. THE CROWN FOR PAVEMENT SHALL BE 1/4" PER FT FROM THE CENTER OF THE CUL-DE-SAC.
3. REFER TO NCDOT STANDARDS FOR DITCH TYPE STREETS IN ETJ.
4. SIDEWALK MAY BE REQUIRED TO EXTEND AROUND CUL-DE-SAC BULB WHERE PARKS OR SCHOOLS HAVE FRONTAGE TO THE END OF THE CUL-DE-SAC.

NOTE: THIS DETAIL IS NOT FOR USE IN ETJ, OR ON NCDOT-MAINTAINED STREETS. REFER TO NCDOT SUBDIVISION ROADS MINIMUM CONSTRUCTION STANDARDS MANUAL.

NOT TO SCALE



CITY OF CHARLOTTE
LAND DEVELOPMENT STANDARDS

CITY OF CHARLOTTE RESIDENTIAL
CUL-DE-SAC DETAIL

STD. NO.	REV.
11.16	23

SIDEWALK (TYP.)

PLANTING STRIP (TYP.)

CURB AND GUTTER (TYP.)

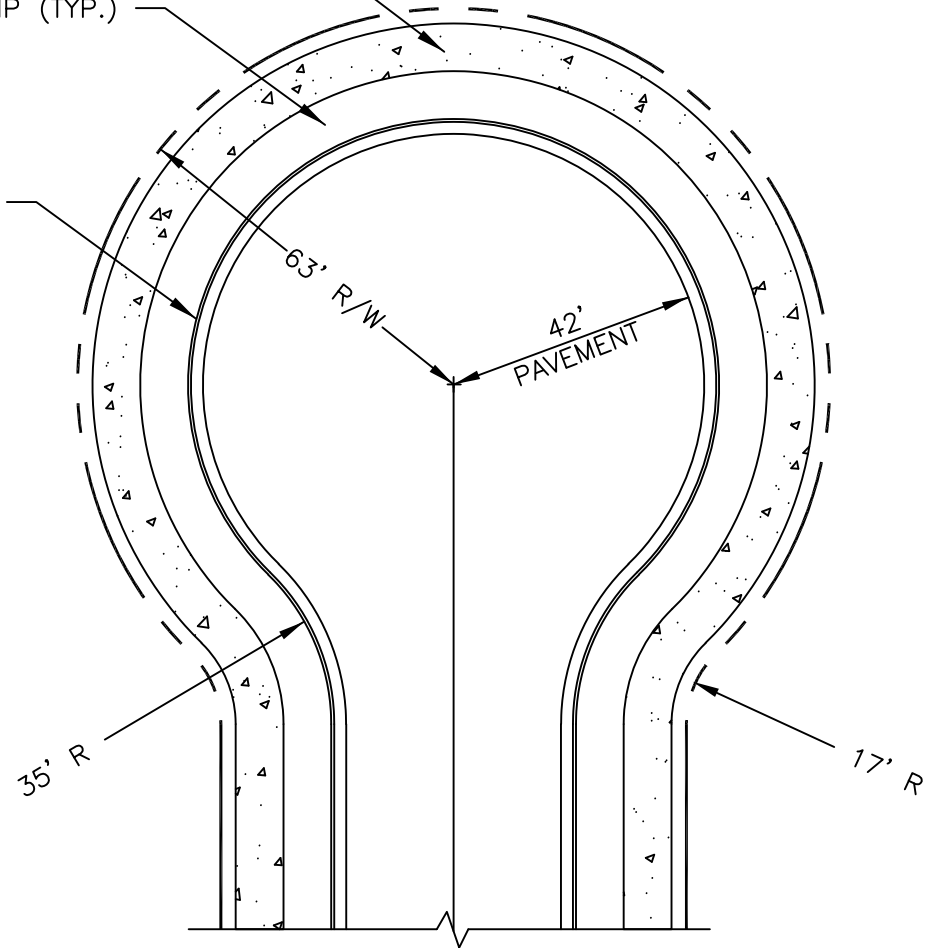

NOTES:

1. ALTERNATIVE CUL-DE-SAC DESIGNS, INCLUDING ISLANDS SHALL BE SUBMITTED TO THE CITY FOR REVIEW AND APPROVAL.
2. PAVEMENT SECTION SHALL CONFORM WITH THE DESIGN REQUIREMENTS FOR COMMERCIAL STREETS.
3. THE CROWN FOR PAVEMENT SHALL BE 1/4" PER FT FROM THE CENTER OF THE CUL-DE-SAC.

NOT TO SCALE



CITY OF CHARLOTTE
 LAND DEVELOPMENT STANDARDS
 INCLUDES CHARLOTTE ETJ

OFFICE / COMMERCIAL / INDUSTRIAL
 CUL-DE-SAC DETAIL

STD. NO.	REV.
11.17	23

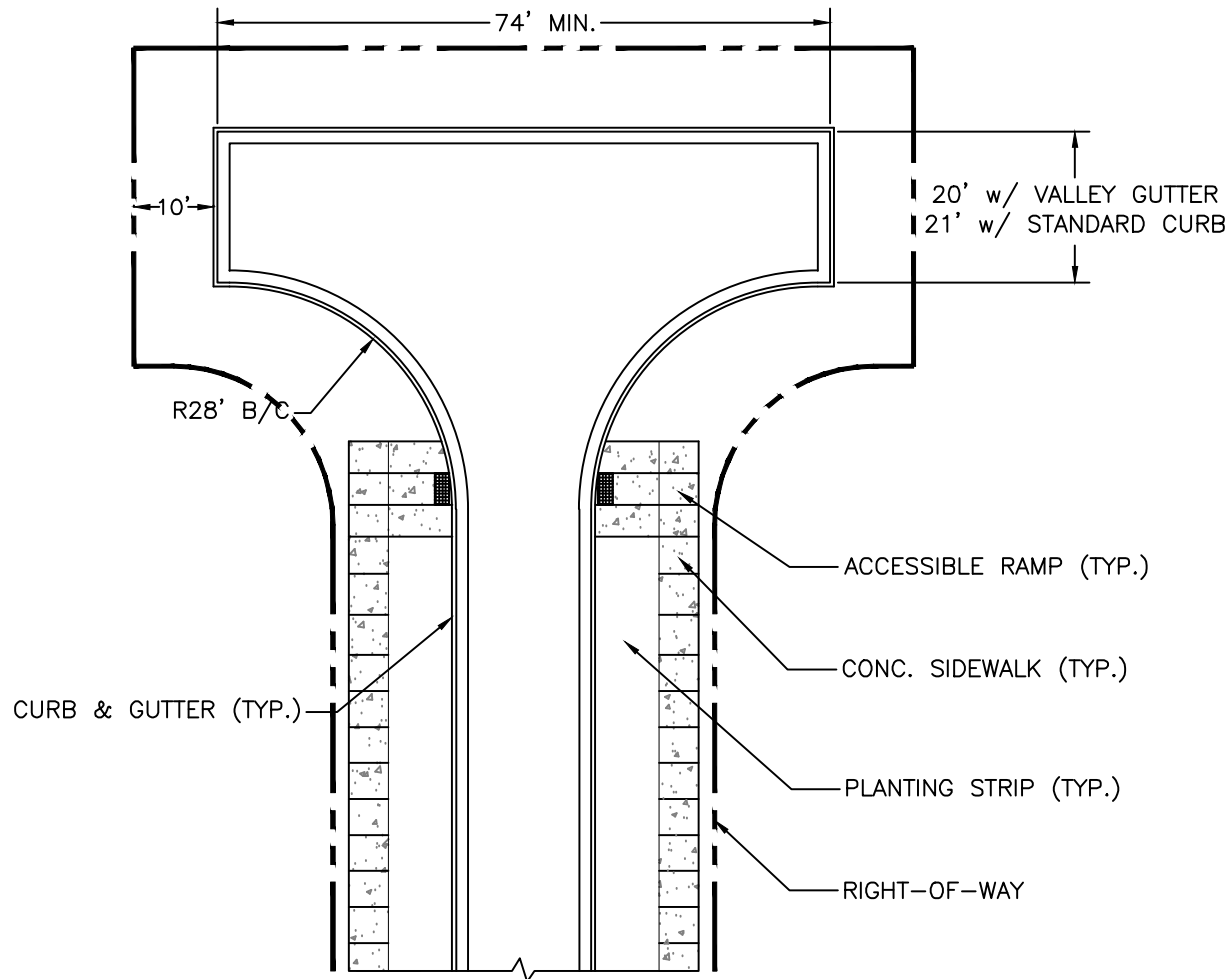

NOTES

1. THIS DESIGN ACCOMMODATES SINGLE-UNIT TRUCK BUT NOT A CHARLOTTE FIRE DEPARTMENT LADDER TRUCK. TO DESIGN FOR A LADDER TRUCK REQUIRES A HAMMERHEAD OF 120 FEET IN LENGTH.
2. VARIATIONS ON THIS DESIGN (E.G., WYES, TURNAROUNDS IN THE STEM, ROTATION OF ENTRY POINT, ETC.) CAN BE SUBMITTED TO CDOT FOR REVIEW AND APPROVAL ON A CASE-BY-CASE BASIS.
3. SIDEWALK MAY BE REQUIRED TO EXTEND AROUND THE HAMMERHEAD WHERE PARKS OR SCHOOLS HAVE FRONTAGE TO THE END OF THE HAMMERHEAD.

NOTE: THIS DETAIL IS NOT FOR USE IN ETJ, OR ON NCDOT-MAINTAINED STREETS. REFER TO NCDOT SUBDIVISION ROADS MINIMUM CONSTRUCTION STANDARDS MANUAL.

NOT TO SCALE



CITY OF CHARLOTTE
LAND DEVELOPMENT STANDARDS

RESIDENTIAL HAMMERHEAD DETAIL

STD. NO.	REV.
11.18A	13

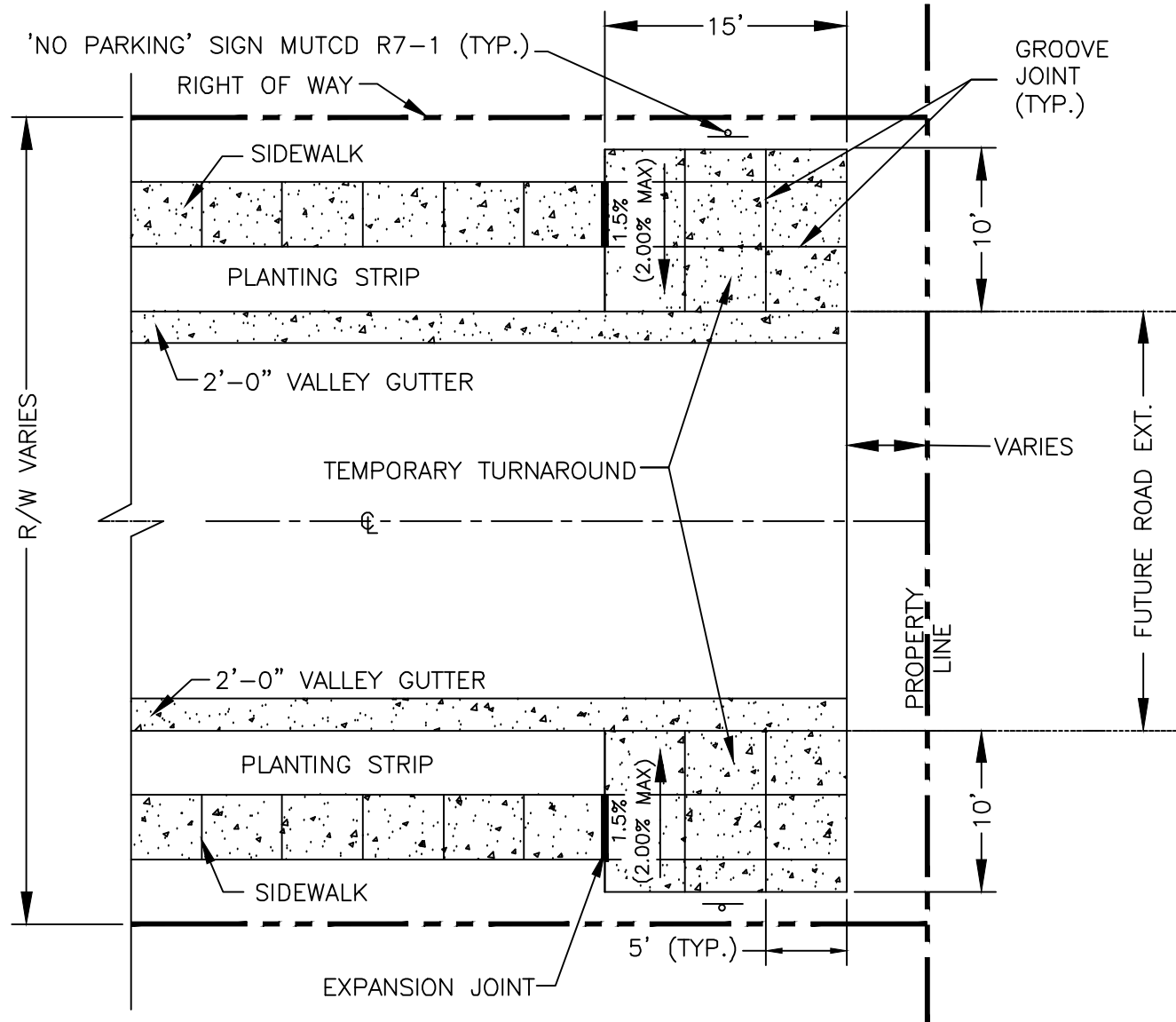

NOTES

1. TEMPORARY TURNAROUND MATERIAL SHALL BE MIN. 3600 PSI CONCRETE, 6" THICK.
2. TEMPORARY INSTALLATION ONLY – TO BE REMOVED WHEN FUTURE DEVELOPMENT CONNECTS TO STREET. "SIDEWALK" PORTION OF TURNAROUND MAY BE LEFT IN PLACE IF NOT DAMAGED.
3. NOT TO BE USED AS A PRIVATE DRIVEWAY.
4. DEAD END STREET BARRICADE AND END OF ROADWAY MARKER PER CLDSM #50.07A&B AND #50.08A, B, & C ARE REQUIRED.

SCALE 1"=10'



CITY OF CHARLOTTE
LAND DEVELOPMENT STANDARDS
 INCLUDES CHARLOTTE ETJ

TEMPORARY TURNAROUND
 LOCAL RESIDENTIAL STREET
 (OPTIONAL)

STD. NO.	REV.
11.18B	13

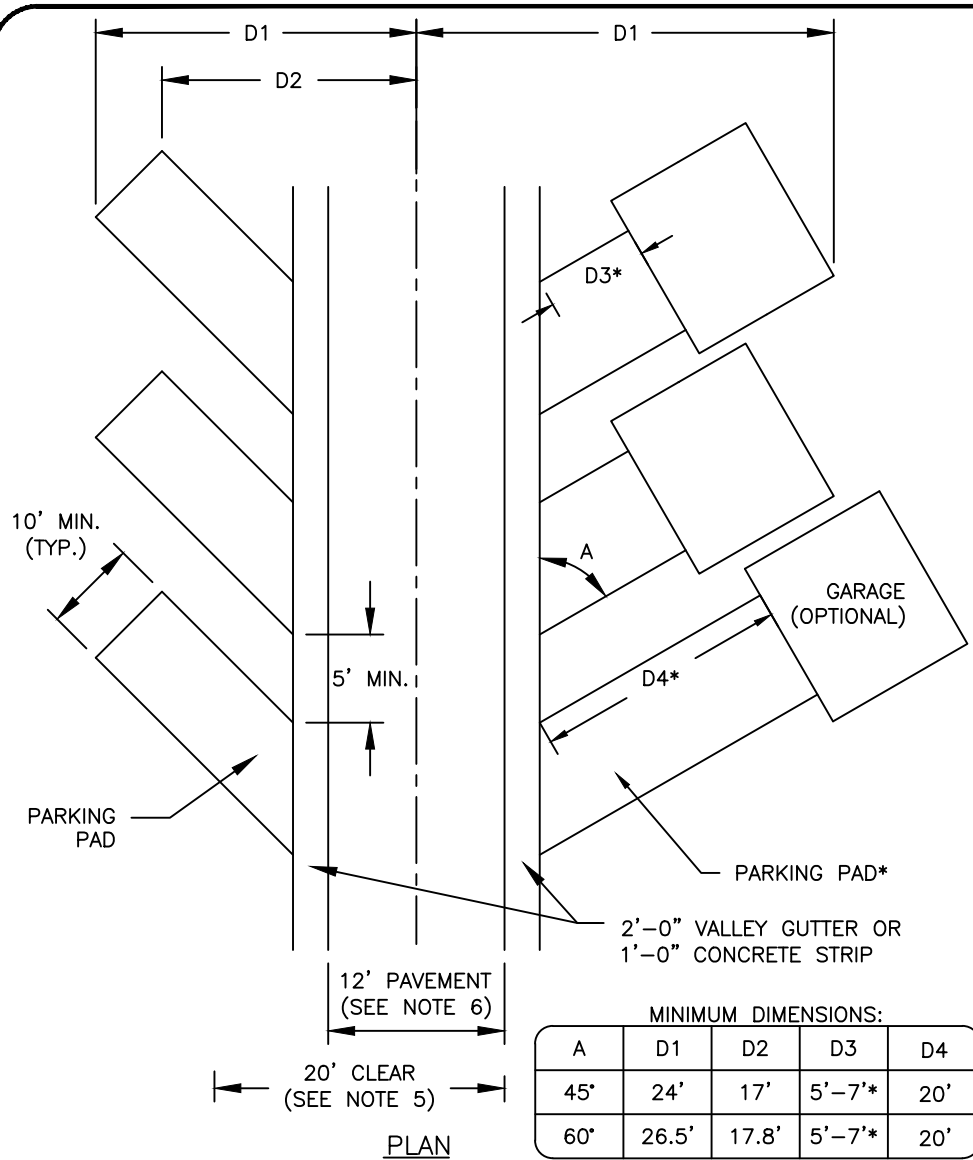

MINIMUM DIMENSIONS:

A	D1	D2	D3	D4
45'	24'	17'	5'-7'*	20'
60'	26.5'	17.8'	5'-7'*	20'

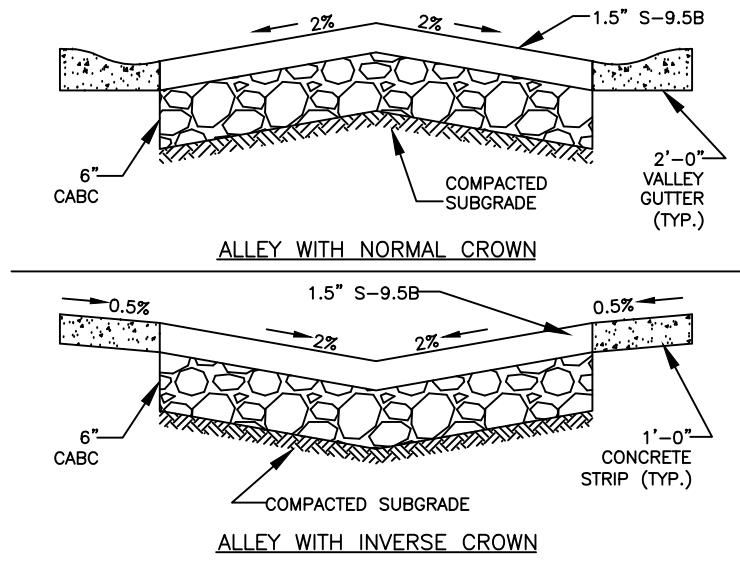

- NOTES:**
1. SUBGRADE SHALL BE COMPACTED TO PUBLIC STREET STANDARDS.
 2. STORM DRAINAGE (NOT SHOWN) SHALL BE PROVIDED AS NECESSARY.
 3. ALLEYS SHALL BE CONSIDERED PRIVATE EASEMENTS AND WILL NOT BE ACCEPTED FOR MAINTENANCE BY THE CITY OF CHARLOTTE.
 4. DRIVEWAYS SHALL BE SEPARATED BY AT LEAST 5 FEET, OR GREATER IF REQUIRED BY PLANNING (LOT SIZE) REQUIREMENTS AND/OR N.C. BUILDING CODE.
 5. DETAIL APPLIES TO SINGLE- OR DOUBLE-LOADED ALLEYS. FOR SINGLE-LOADED ALLEYS, THERE SHALL BE A 20-FOOT CLEAR ZONE FREE OF CUT SLOPES, OBSTRUCTIONS, HEDGES, ETC. FROM THE LOADED SIDE EDGE OF PAVEMENT.
 6. MINIMUM 20' WIDE PAVEMENT REQUIRED IF ALLEY IS TO BE CONSIDERED A "FIRE APPARATUS ACCESS ROAD" PER NC FIRE CODE.
- * WITH NO PARKING PAD, DIMENSION D3 IS REQUIRED TO BE MINIMUM 5' BUT NO GREATER THAN 7'. WITH PARKING PAD, DIMENSION D4 IS REQUIRED TO BE A MINIMUM OF 20'.

NOT TO SCALE



CITY OF CHARLOTTE
LAND DEVELOPMENT STANDARDS
 INCLUDES CHARLOTTE ETJ

RESIDENTIAL ALLEY DETAIL
 ONE-WAY OPERATION

STD. NO.	REV.
11.19A	17

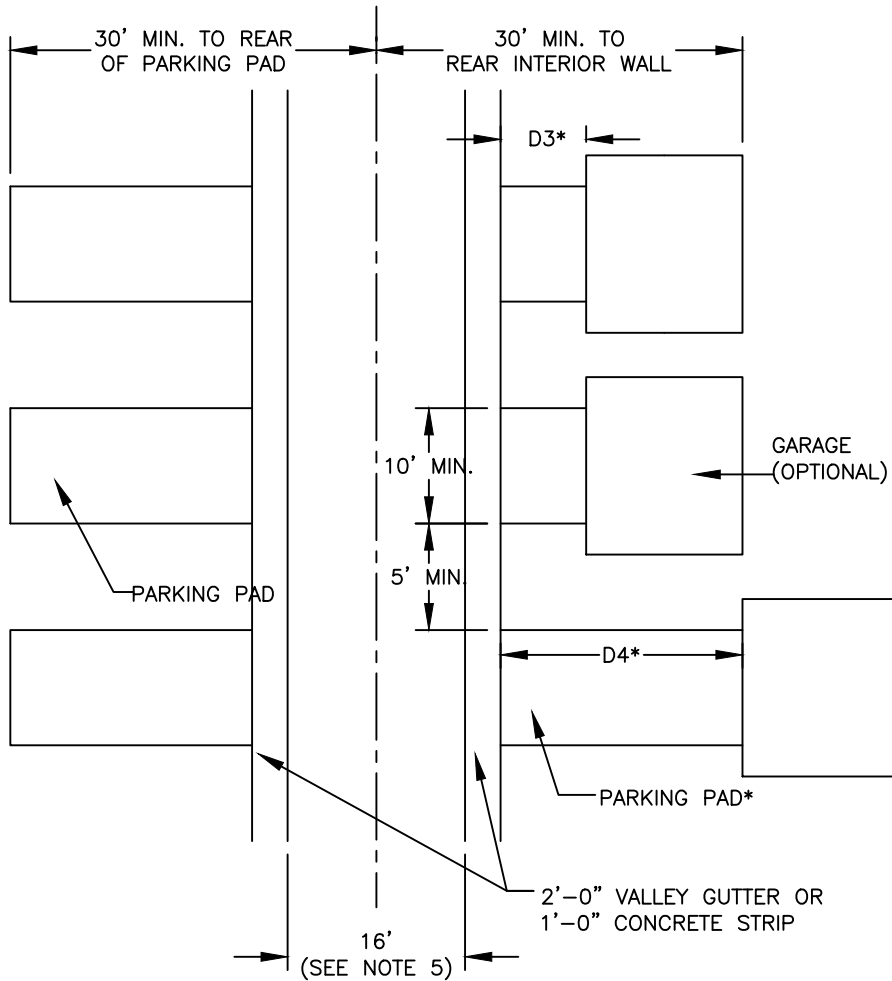

PLAN

* WITH NO PARKING PAD, DIMENSION D3 IS REQUIRED TO BE MINIMUM 5' BUT NO GREATER THAN 7'. WITH PARKING PAD, DIMENSION D4 IS REQUIRED TO BE A MINIMUM OF 20'.

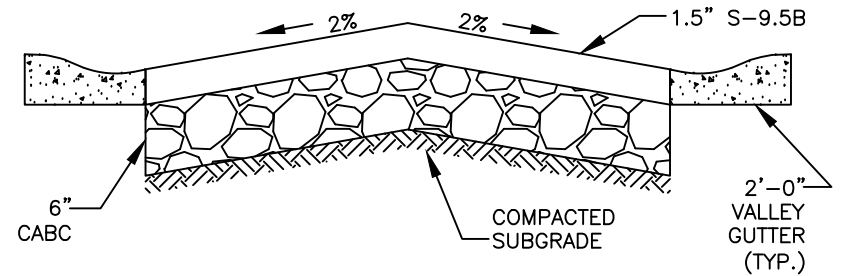

ALLEY WITH NORMAL CROWN

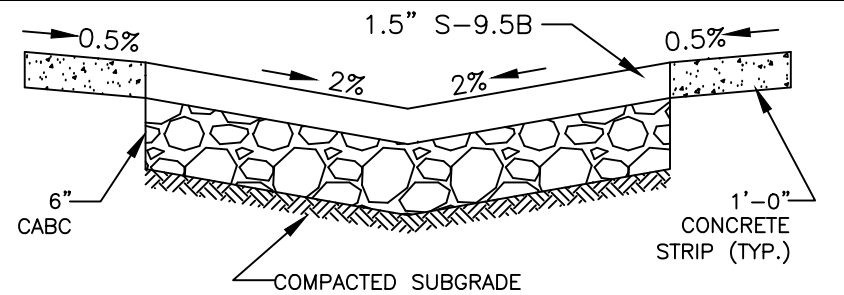

ALLEY WITH INVERSE CROWN

NOTES:

1. SUBGRADE SHALL BE COMPACTED TO PUBLIC STREET STANDARDS.
2. STORM DRAINAGE (NOT SHOWN) SHALL BE PROVIDED AS NECESSARY.
3. ALLEYS SHALL BE CONSIDERED PRIVATE EASEMENTS AND WILL NOT BE ACCEPTED FOR MAINTENANCE BY THE CITY OF CHARLOTTE.
4. DRIVEWAYS SHALL BE SEPARATED BY AT LEAST 5 FEET, OR GREATER IF REQUIRED BY PLANNING (LOT SIZE) REQUIREMENTS AND/OR N.C. BUILDING CODE.
5. MINIMUM 20' WIDE PAVEMENT REQUIRED IF ALLEY IS TO BE CONSIDERED A "FIRE APPARATUS ACCESS ROAD" PER NC FIRE CODE.

NOT TO SCALE



CITY OF CHARLOTTE
LAND DEVELOPMENT STANDARDS
INCLUDES CHARLOTTE ETJ

RESIDENTIAL ALLEY DETAIL
DOUBLE LOADED W/ TWO-WAY OPERATION

STD. NO.	REV.
11.19B	17

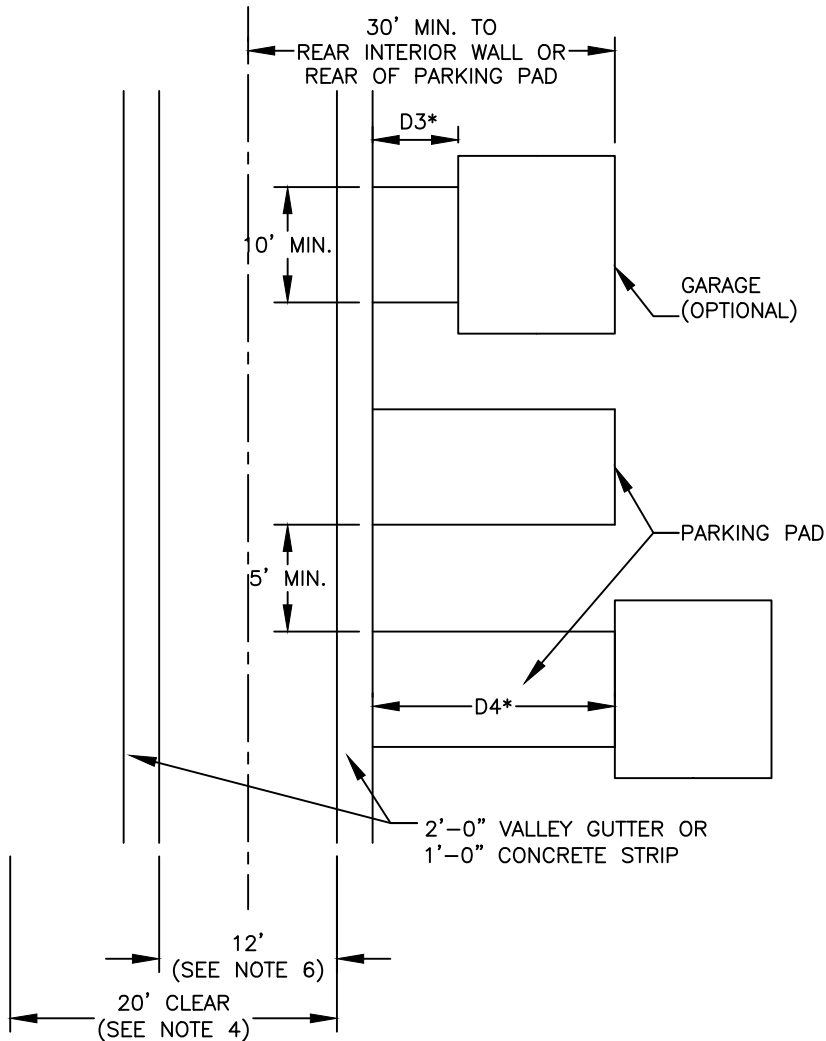

PLAN

* WITH NO PARKING PAD, DIMENSION D3 IS REQUIRED TO BE MINIMUM 5' BUT NO GREATER THAN 7'. WITH PARKING PAD, DIMENSION D4 IS REQUIRED TO BE A MINIMUM OF 20'.

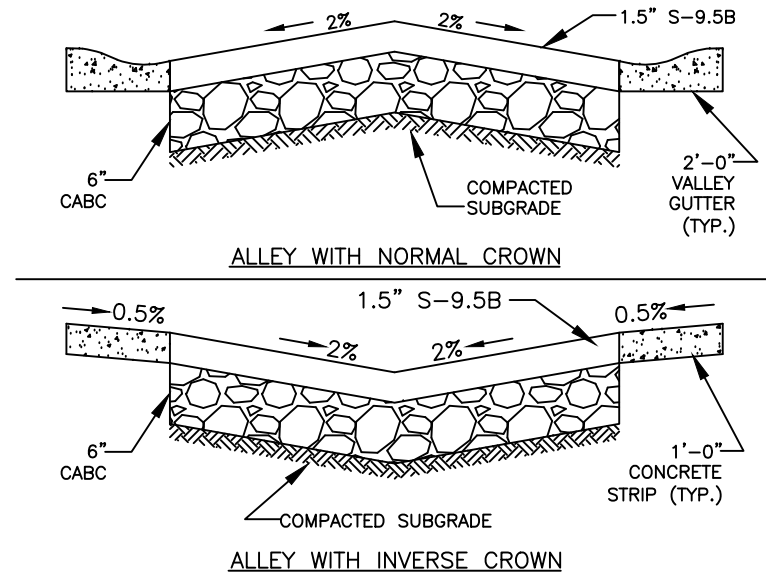

NOTES:

1. SUBGRADE SHALL BE COMPACTED TO PUBLIC STREET STANDARDS.
2. STORM DRAINAGE (NOT SHOWN) SHALL BE PROVIDED AS NECESSARY.
3. ALLEYS SHALL BE CONSIDERED PRIVATE EASEMENTS AND WILL NOT BE ACCEPTED FOR MAINTENANCE BY THE CITY OF CHARLOTTE.
4. NO CUT SLOPES, OBSTRUCTIONS, HEDGES, ETC. ON NON-LOADED SIDE OF ALLEY WITHIN 20 FEET OF LOADED SIDE EDGE OF PAVEMENT.
5. DRIVEWAYS SHALL BE SEPARATED BY AT LEAST 5 FEET, OR GREATER IF REQUIRED BY PLANNING (LOT SIZE) REQUIREMENTS AND/OR N.C. BUILDING CODE.
6. MINIMUM 20' WIDE PAVEMENT REQUIRED IF ALLEY IS TO BE CONSIDERED A "FIRE APPARATUS ACCESS ROAD" PER NC FIRE CODE.

NOT TO SCALE



CITY OF CHARLOTTE
LAND DEVELOPMENT STANDARDS
INCLUDES CHARLOTTE ETJ

RESIDENTIAL ALLEY DETAIL
SINGLE LOADED W/ TWO-WAY OPERATION

STD. NO.	REV.
11.19C	17

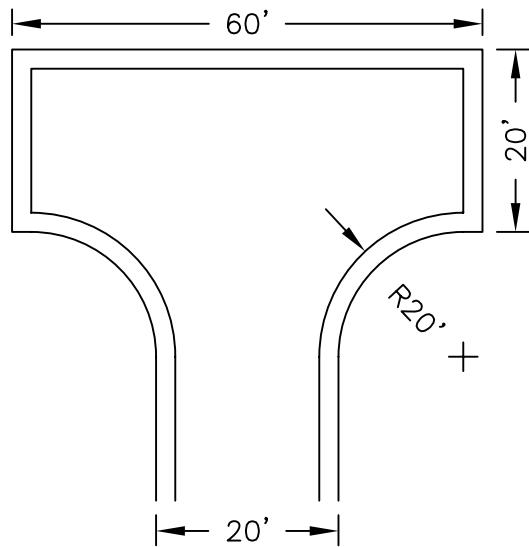

STANDARD HAMMERHEAD

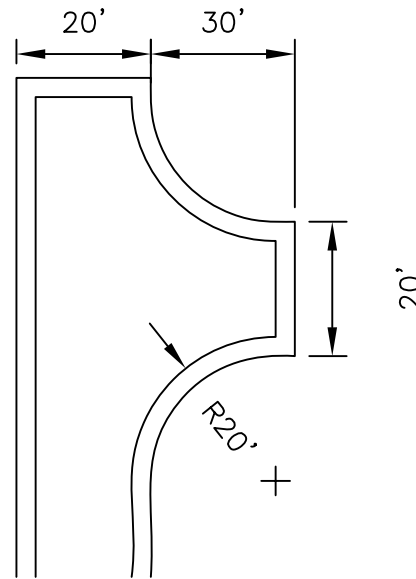

ROTATED HAMMERHEAD

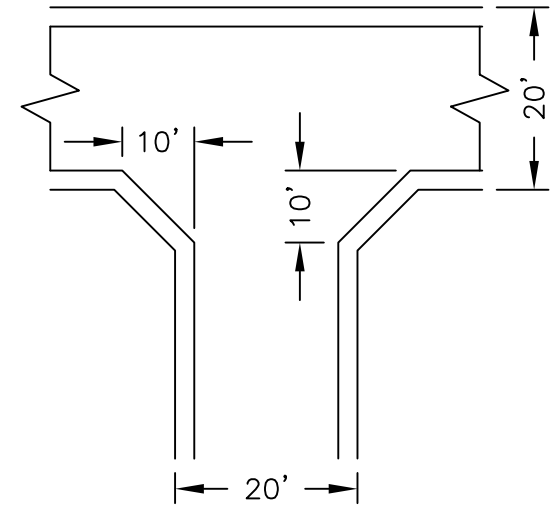

STANDARD INTERSECTION

NOTES:

1. SEE DETAILS 11.19A-B FOR ALLEY DESIGN STANDARDS.
2. HAMMERHEAD DETAILS APPLY ONLY FOR TWO-WAY ALLEYS. ONE-WAY ALLEYS MUST CONNECT TO A PUBLIC STREET OR ANOTHER ALLEY.
3. FOR INTERSECTIONS WITH A LEAST ONE (1) ONE-WAY ALLEY, THE BACK-OF-CURB TO BACK-OF-CURB WIDTH CAN BE 16 FEET ON THE APPROPRIATE LEG(S) INSTEAD OF THE 20 FEET SHOWN.
4. OTHER INTERSECTION DESIGNS WILL BE APPROVED BY CDOT ON A CASE-BY-CASE BASIS.
5. THIS DETAIL DOES NOT ACCOMMODATE COMMERCIAL VEHICLES OR CHARLOTTE FIRE DEPARTMENT DESIGN FIRE TRUCK.
6. ADEQUATE STOPPING SIGHT DISTANCE (SSD) SHALL BE PROVIDED AT EACH INTERSECTION. MINIMUM SSD SHALL BE 50 FEET ASSUMING AN OPERATIONAL SPEED OF 10 MPH.



CITY OF CHARLOTTE
LAND DEVELOPMENT STANDARDS
INCLUDES CHARLOTTE ETJ

RESIDENTIAL ALLEY HAMMERHEADS
AND INTERSECTIONS

STD. NO.	REV.
11.20	

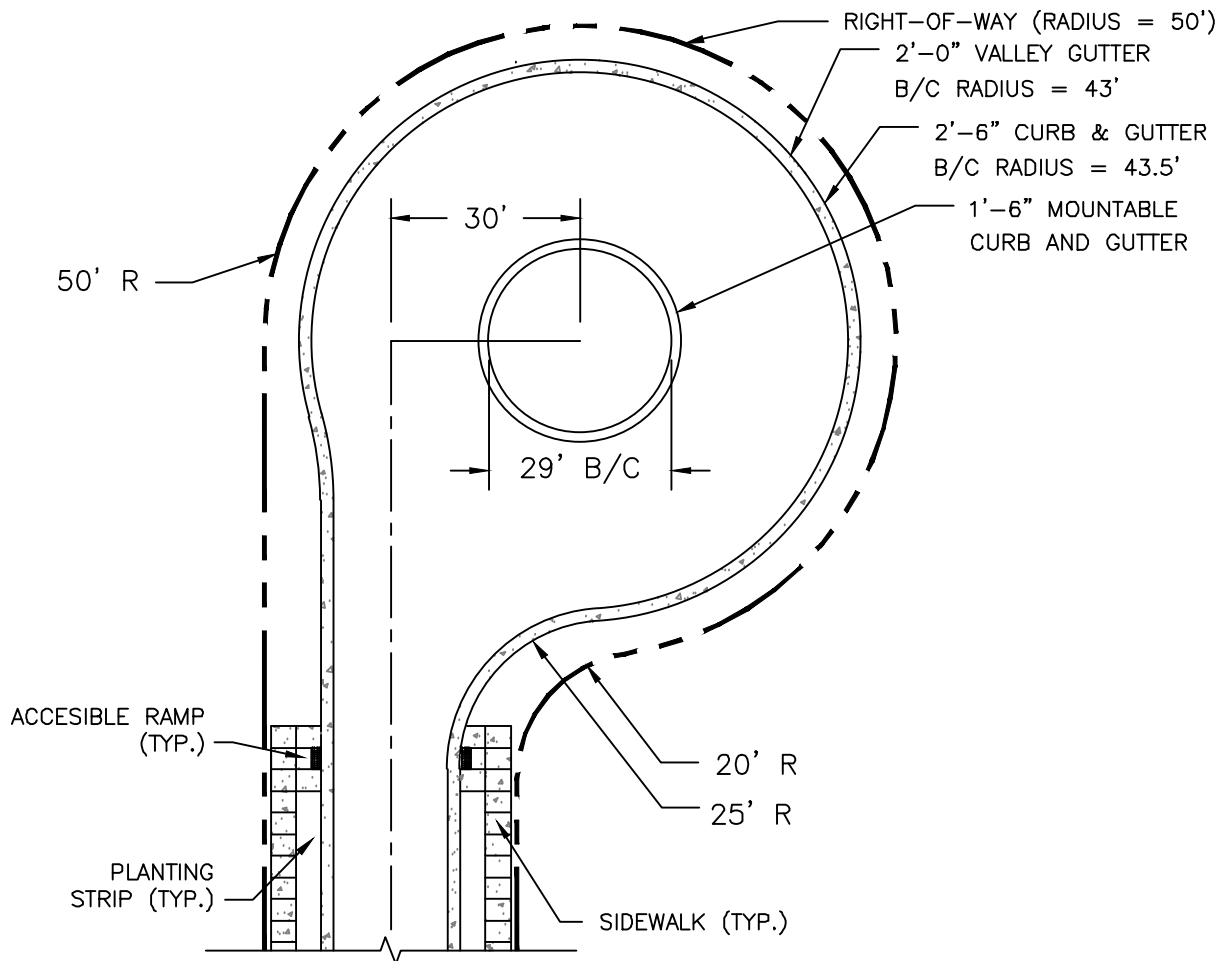

NOTES:

1. THE CENTRAL ISLAND SHALL BE PUBLIC RIGHT-OF-WAY.
2. THE CENTRAL ISLAND WILL NOT BE MAINTAINED BY THE CITY OF CHARLOTTE. A PROPERTY OWNERS' ASSOCIATION OR PRIVATE ENTITY WILL BE RESPONSIBLE FOR MAINTENANCE OF THE ISLAND.
3. ONLY GRASS, FLOWERS, GROUND COVER, ETC., WITH A MATURE HEIGHT OF 30 INCHES OR LESS WILL BE ALLOWED TO BE PLANTED IN THE CENTRAL ISLAND WITHOUT AN ENCROACHMENT AGREEMENT. ANY NONSTANDARD ITEM, E.G., BENCHES, IRRIGATION, ETC., PLACED IN THE ISLAND REQUIRES AN ENCROACHMENT AGREEMENT PRIOR TO INSTALLATION. CDOT REVIEWS EACH ENCROACHMENT REQUEST ON A CASE-BY-CASE BASIS AND MAY NOT APPROVE ENCROACHMENTS FOR ALL ITEMS REQUESTED.
4. WHERE NECESSARY, A SIDEWALK EASEMENT SHALL BE PROVIDED FOR ALL SIDEWALK LOCATED OUTSIDE THE PUBLIC RIGHT-OF-WAY. THE EASEMENT SHALL EXTEND FROM THE RIGHT-OF-WAY LINE TO TWO (2) FEET BEHIND THE BACK OF SIDEWALK, OR TO THE FACE OF BUILDING, WHICHEVER IS LESS.
5. SIDEWALK SHALL BE PROVIDED AS REQUIRED BY APPLICABLE ORDINANCE(S).
6. CUL-DE-SAC CAN BE OFFSET LEFT, OFFSET RIGHT, OR SYMMETRIC.
7. SIDEWALK MAY BE REQUIRED TO EXTEND AROUND CUL-DE-SAC BULB WHERE PARKS OR SCHOOLS HAVE FRONTAGE TO THE END OF THE CUL-DE-SAC.
8. ALL CURB RADII SHOWN ARE DIMENSIONED TO BACK-OF-CURB

NOTE: THIS DETAIL IS NOT FOR USE IN ETJ, OR ON NCDOT-MAINTAINED STREETS. REFER TO NCDOT SUBDIVISION ROADS MINIMUM CONSTRUCTION STANDARDS MANUAL.

NOT TO SCALE



CITY OF CHARLOTTE
LAND DEVELOPMENT STANDARDS

OVERSIZED RESIDENTIAL CUL-DE-SAC
WITH RAISED PLANTER ISLAND

STD. NO.	REV.
11.21	13

DWG	SHEET TITLE	SPECIAL REQUIREMENTS AND NOTES
300.01	METHOD OF PIPE INSTALLATION	
310.02	PARALLEL PIPE END SECTION-PRECAST CONCRETE FOR 15" TO 24" PIPE	REQUIRED IN RIGHT OF WAY WITHIN THE ETJ
310.03	CROSS PIPE END SECTION-PRECAST CONCRETE FOR 18" TO 30" PIPE	REQUIRED IN RIGHT OF WAY WITHIN THE ETJ
310.10	DRIVEWAY PIPE CONSTRUCTION USING NO SPECIAL END SECTIONS	ONLY AT LOCATIONS APPROVED BY THE CITY
815.03	PIPE UNDERDRAIN AND BLIND DRAIN	
838.01	CONCRETE ENDWALL FOR SINGLE AND DOUBLE PIPE CULVERTS 15" THRU 48" PIPE 90' SKEW	NOTE 1 NOTE 1
838.02	CONCRETE ENDWALL AND SLUICE GATE 15" THRU 36" PIPE-90' SKEW	NOTE 1
838.04	CONCRETE ENDWALL FOR SINGLE AND DOUBLE PIPE CULVERTS 17"X13"THRU 71"X47" PIPE ARCH 90' SKEW	NOTE 1 NOTE 1
838.05	CONCRETE "L" ENDWALL FOR SINGLE PIPE CULVERTS 15" THRU 48" PIPE	NOTE 1
838.06	CONCRETE "L" ENDWALL FOR SINGLE PIPE CULVERTS 17"X13" THRU 71"X47" 71"X47" ARCH PIPE	NOTE 1 NOTE 1
838.07	CONCRETE ENDWALL FOR SINGLE AND DOUBLE PIPE CULVERTS 40"X31" THRU 66"X51" PIPE ARCH 90'SKEW	NOTE 1 NOTE 1
838.08	CONCRETE "L" ENDWALL FOR SINGLE PIPE CULVERTS 40"X32" THRU 66"X51" PIPE ARCH	NOTE 1 NOTE 1
838.10	CONCRETE ENDWALL FOR OUTFALL 4'-6" OR 8" PIPE	NOTE 1
838.11	BRICK ENDWALL FOR SINGLE AND DOUBLE PIPE CULVERTS 15" THRU 48" 90' SKEW	NOTE 1 NOTE 1
838.14	BRICK ENDWALL FOR SINGLE AND DOUBLE PIPE CULVERTS 17"X31" THRU 71"X47" 90' SKEW	NOTE 1 NOTE 1
838.15	BRICK "L" ENDWALL FOR SINGLE PIPE CULVERTS 15" THRU 48" PIPE	NOTE 1
838.16	BRICK "L" ENDWALL FOR SINGLE PIPE CULVERTS 17"X13" THRU 71"X47" PIPE ARCH	NOTE 1 NOTE 1
838.17	BRICK ENDWALL FOR SINGLE AND DOUBLE PIPE CULVERTS 40"X31" THRU 66"X51" PIPE ARCH 90'SKEW	NOTE 1 NOTE 1
838.18	BRICK ENDWALL FOR SINGLE PIPE CULVERTS 40"X31" THRU 66"X51" PIPE ARCH 90' SKEW	NOTE 1 NOTE 1
838.20	BRICK ENDWALL FOR OUTFALL 4", 6" AND 8" PIPE	NOTE 1
838.21	REINFORCED CONCRETE ENDWALL FOR SINGLE 54" PIPE 90' SKEW	NOTE 1; SEE CLDS 20.17 FOR SPLASH PAD
838.22	REINFORCED CONCRETE ENDWALL FOR DOUBLE & TRIPLE 54" PIPE 90' SKEW	NOTE 1; SEE CLDS 20.17 FOR SPLASH PAD
838.27	REINFORCED CONCRETE ENDWALL FOR SINGLE 60" PIPE 90' SKEW	NOTE 1; SEE CLDS 20.17 FOR SPLASH PAD
838.28	REINFORCED CONCRETE ENDWALL FOR DOUBLE & TRIPLE 60" PIPE 90' SKEW	NOTE 1; SEE CLDS 20.17 FOR SPLASH PAD
838.33	REINFORCED CONCRETE ENDWALL FOR SINGLE 66" PIPE 90' SKEW	NOTE 1; SEE CLDS 20.17 FOR SPLASH PAD
838.34	REINFORCED CONCRETE ENDWALL FOR DOUBLE & TRIPLE 66" PIPE 90' SKEW	NOTE 1; SEE CLDS 20.17 FOR SPLASH PAD
838.39	REINFORCED CONCRETE ENDWALL FOR SINGLE 72" PIPE 90' SKEW	NOTE 1; SEE CLDS 20.17 FOR SPLASH PAD
838.40	REINFORCED CONCRETE ENDWALL FOR DOUBLE & TRIPLE 72" PIPE 90' SKEW	NOTE 1; SEE CLDS 20.17 FOR SPLASH PAD

NOTE 1: FOR ALL STRUCTURES – ALL CONCRETE USED FOR DRAINAGE STRUCTURES SHALL HAVE A MINIMUM COMPRESSIVE STRENGTH OF 3600 PSI AT 28 DAYS. THIS REQUIREMENT SHALL BE PROVIDED REGARDLESS OF ANY LESSER COMPRESSIVE STRENGTH SPECIFIED IN THE NORTH CAROLINA DEPARTMENT OF TRANSPORTATION STANDARD SPECIFICATIONS FOR ROADS AND STRUCTURES.



CITY OF CHARLOTTE
LAND DEVELOPMENT STANDARDS
INCLUDES CHARLOTTE ETJ

NCDOT STANDARDS
APPROVED FOR USE IN THE CITY OF CHARLOTTE
AND CHARLOTTE ETJ

STD. NO.	REV.
20.00A	24

DWG	SHEET TITLE	SPECIAL REQUIREMENTS AND NOTES
838.45	NOTES FOR REINFORCED CONCRETE ENDWALL STANDARD DRAWINGS 838.21 THRU 838.40	NOTE 1 SEE CLDS 20.17 FOR SPLASH PAD NOTE 1 SEE CLDS 20.17 FOR SPLASH PAD
838.51	REINFORCED BRICK ENDWALL FOR SINGLE 54" PIPE 90' SKEW	NOTE 1 SEE CLDS 20.17 FOR SPLASH PAD
838.52	REINFORCED BRICK ENDWALL FOR DOUBLE & TRIPLE 54" PIPE 90'SKEW	NOTE 1 SEE CLDS 20.17 FOR SPLASH PAD
838.57	REINFORCED BRICK ENDWALL FOR SINGLE 60" PIPE 90' SKEW	NOTE 1 SEE CLDS 20.17 FOR SPLASH PAD
838.58	REINFORCED BRICK ENDWALL FOR DOUBLE & TRIPLE 60" PIPE 90' SKEW	NOTE 1 SEE CLDS 20.17 FOR SPLASH PAD
838.63	REINFORCED BRICK ENDWALL FOR SINGLE 66" PIPE 90' SKEW	NOTE 1 SEE CLDS 20.17 FOR SPLASH PAD
838.64	REINFORCED BRICK ENDWALL FOR DOUBLE & TRIPLE 66" PIPE 90' SKEW	NOTE 1 SEE CLDS 20.17 FOR SPLASH PAD
838.69	REINFORCED BRICK ENDWALL FOR SINGLE 72" PIPE 90' SKEW	NOTE 1 SEE CLDS 20.17 FOR SPLASH PAD
838.70	REINFORCED BRICK ENDWALL FOR DOUBLE & TRIPLE 72" PIPE 90' SKEW	NOTE 1 SEE CLDS 20.17 FOR SPLASH PAD
838.75	NOTES FOR REINFORCED BRICK ENDWALL STANDARD DRAWINGS 838.51 THRU 838.70	NOTE 1 SEE CLDS 20.17 FOR SPLASH PAD
838.80	PRECAST CONCRETE ENDWALL FOR SINGLE 12" THRU 72" PIPE 90' SKEW	
840.00	CONCRETE BASE PAD FOR DRAINAGE STRUCTURES	
840.01	BRICK CATCH BASIN 15" THRU 54" PIPE	
840.02	CONCRETE CATCH BASIN 12" THRU 54" PIPE	
840.03	FRAME, GRATE BASIN 12" THRU 54" PIPE	TYPE F AND G GRATES ARE OPTIONAL WITHIN THE CITY LIMITS
840.04	CONCRETE OPEN THROAT CATCH BASIN 12" THRU 48" PIPE	NOTE 1; OPENINGS PERMITTED IN 4 SIDES OUTSIDE OF STREET R/W MANHOLE RING AND COVER REQUIRED IN TOP SLAB SEE 840.55
840.05	BRICK OPEN THROAT CATCH BASIN 15" THRU 48" PIPE	NOTE 1; OPENINGS PERMITTED IN 4 SIDES OUTSIDE OF STREET R/W MANHOLE RING AND COVER REQUIRED IN TOP SLAB SEE 840.55
840.14	CONCRETE DROP INLET 12" THRU 30" PIPE	NOTE 1
840.15	BRICK DROP INLET 12" THRU 30' PIPE	NOTE 1
840.16	DROP INLET FRAME AND GRATE FOR USE WITH DWGS. 840.14 & 840.15	NOTE 1
840.17	CONCRETE GRATED DROP INLET TYPE "A" 12" THRU 72" PIPE	NOTE 1
840.18	CONCRETE GRATED DROP INLET TYPE "B" 12" THRU 36" PIPE	NOTE 1
840.19	CONCRETE GRATED DROP INLET TYPE "D" 12" THRU 36" PIPE	NOTE 1
840.20	FRAMES AND WIDE SLOT FLAT GRATES	NOT FOR USE IN PEDESTRIAN/BICYCLE AREAS
840.22	FRAMES AND WIDE SLOT SAG GRATES	NOT FOR USE IN PEDESTRIAN/BICYCLE AREAS
840.24	FRAMES AND NARROW SLOT SAG GRATES	
840.25	ANCHORAGE FOR FRAMES BRICK OR CONCRETE	
840.26	BRICK GRATED DROP INLET TYPE "A" 12" THRU 72" PIPE	
840.27	BRICK GRATED DROP INLET TYPE "B" 12" THRU 36" PIPE	
840.28	BRICK GRATED DROP INLET TYPE "D" 12" THRU 36" PIPE	
840.29	FRAMES AND NARROW SLOT FLAT GRATES	
840.30	DRIVEWAY DROP INLET	
840.39	BICYCLE SAFE STEEL FRAME AND GRATE	

NOTE 1: FOR ALL STRUCTURES – ALL CONCRETE USED FOR DRAINAGE STRUCTURES SHALL HAVE A MINIMUM COMPRESSIVE STRENGTH OF 3600 PSI AT 28 DAYS. THIS REQUIREMENT SHALL BE PROVIDED REGARDLESS OF ANY LESSER COMPRESSIVE STRENGTH SPECIFIED IN THE NORTH CAROLINA DEPARTMENT OF TRANSPORTATION STANDARD SPECIFICATIONS FOR ROADS AND STRUCTURES.



CITY OF CHARLOTTE
LAND DEVELOPMENT STANDARDS
INCLUDES CHARLOTTE ETJ

NCDOT STANDARDS
APPROVED FOR USE IN THE CITY OF CHARLOTTE
AND CHARLOTTE ETJ

STD. NO.	REV.
20.00B	24

DWG	SHEET TITLE	SPECIAL REQUIREMENTS AND NOTES
840.31	CONCRETE JUNCTION BOX (WITH OPTIONAL MANHOLE) 12" THRU 66" PIPE	NOTE 1; OPTIONAL MANHOLE IS REQUIRED
840.32	BRICK JUNCTION BOX 12" THRU 66" PIPE	NOTE 1; OPTIONAL MANHOLE IS REQUIRED
840.34	TRAFFIC BEARING JUNCTION BOX FOR USE WITH PIPES 42" AND UNDER	NOTE 1; OPTIONAL MANHOLE IS REQUIRED; AS MEASURED FROM BOTTOM OF TOP SLAB -- FOR JUNCTION BOX HEIGHT 0'-4'8" USE 8" THICK WALL, FROM 4'8" HEIGHT TO 10' HEIGHT, USE 12" THICK WALL. IF PROPOSED STRUCTURE EXCEEDS 12'-0" HEIGHT A SPECIAL DESIGN WILL BE REQUIRED
840.35	TRAFFIC BEARING DROP INLET FOR CAST IRON DOUBLE FRAME AND GRATES	
840.36	TRAFFIC BEARING DROP INLET FOR STEEL (840.37) DOUBLE FRAME AND GRATES	NOT FOR USE IN PEDESTRIAN AREAS
840.37	STEEL GRATE AND FRAME	NOT FOR USE IN PEDESTRIAN AREAS
840.41	SPRING BOX CONCRETE OR BRICK	
840.45	PRECAST DRAINAGE STRUCTURE (SOLID AND WAFFLE WALL)	WAFFLE WALL IS NOT PERMITTED IN ROADWAY, PLANTING STRIPS, OR MEDIANS. ALL OPENINGS SHALL BE PRE-CAST
840.46	TRAFFIC BEARING PRECAST DRAINAGE STRUCTURE	
840.51	BRICK MANHOLE 12" 36" PIPE	
840.52	PRECAST MANHOLE 4', 5' AND 6' DIAMETER 12" THRU 48" PIPE	IF USED AS A CATCH BASIN SUPPORTING NCDOT 840.03 FRAME, GRATE, AND HOOD - THE FLAT TOP SLAB ONLY ACCEPTABLE WHEN A 12" VERTICAL RISER CAN BE ACCOMMODATED ON TOP OF THE STRUCTURE (BETWEEN THE TOP OF FLAT TOP SLAB AND BOTTOM OF FRAME/GRATE)
840.53	PRECAST MANHOLE WITH MASONRY BASE 12" THRU 42" PIPE	IF USED AS A CATCH BASIN SUPPORTING NCDOT 840.03 FRAME, GRATE, AND HOOD - THE FLAT TOP SLAB ONLY ACCEPTABLE WHEN A 12" VERTICAL RISER CAN BE ACCOMMODATED ON TOP OF THE STRUCTURE (BETWEEN THE TOP OF FLAT TOP SLAB AND BOTTOM OF FRAME/GRATE)
840.54	MANHOLE FRAME AND COVER	ALL COVERS SHALL BE SUPPLIED WITH A MINIMUM OF TWO AND A MAXIMUM OF SIX 1-INCH DIAMETER VENT HOLES.
840.55	MANHOLE FRAME AND COVER (FLUSH WITH SLAB FOR OPEN THROAT CB)	ALL COVERS SHALL BE SUPPLIED WITH A MINIMUM OF TWO AND A MAXIMUM OF SIX 1-INCH DIAMETER VENT HOLES.
840.66	DRAINAGE STRUCTURE STEPS	
840.71	CONCRETE AND BRICK PIPE PLUG	
840.72	PIPE COLLAR	
850.01	CONCRETE PAVED DITCHES	
852.04	METHODS FOR PLACEMENT OF DROP INLETS IN GRASSED MEDIAN (USING 1'-6" CURB AND GUTTER)	
852.05	MEDIAN CURB FOR CATCH BASIN (FOR USE WITH 1'-6" CURB AND GUTTER)	
852.06	METHOD OF PLACEMENT OF DROP INLETS IN CONCRETE ISLANDS	
876.01	RIP RAP IN CHANNELS	
876.02	GUIDE FOR RIP RAP AT PIPE OUTLETS	
876.03	DRAINAGE DITCHES WITH CLASS "A" RIP RAP	
876.04	DRAINAGE DITCHES WITH CLASS "B" RIP RAP	

NOTE 1: FOR ALL STRUCTURES - ALL CONCRETE USED FOR DRAINAGE STRUCTURES SHALL HAVE A MINIMUM COMPRESSIVE STRENGTH OF 3600 PSI AT 28 DAYS. THIS REQUIREMENT SHALL BE PROVIDED REGARDLESS OF ANY LESSER COMPRESSIVE STRENGTH SPECIFIED IN THE NORTH CAROLINA DEPARTMENT OF TRANSPORTATION STANDARD SPECIFICATIONS FOR ROADS AND STRUCTURES.



CITY OF CHARLOTTE
LAND DEVELOPMENT STANDARDS
 INCLUDES CHARLOTTE ETJ

NCDOT STANDARDS
 APPROVED FOR USE IN THE CITY OF CHARLOTTE
 AND CHARLOTTE ETJ

STD. NO.	REV.
20.00C	24

GENERAL NOTES:

1. NOT FOR USE ON NCDOT-MAINTAINED ROADWAYS OR WITHIN THE CITY OF CHARLOTTE ETJ.
2. SEE NCDOT STANDARD 840.01 FOR DETAILS BASED ON PIPE SIZE PER CROSS SECTION.
3. CONSTRUCT TWO SINGLE BASINS PER NCDOT STANDARD WITH DOUBLE INTERIOR WALL.
4. ALL CONCRETE TO BE 3600 P.S.I COMPRESSIVE STRENGTH.
5. BASE SLAB SHALL BE MONOLITHIC.
6. SEE CLDSM STANDARDS #10.29 AND #10.30 FOR PLACEMENT OF CATCH BASIN.
7. PIPE SECTION D2 CONNECTING CATCH BASINS SHALL HAVE A MINIMUM DIAMETER SAME AS OF OUTLET PIPE D3.
8. ALL REINFORCING STEEL SHOWN ON NCDOT STANDARDS IS TO BE PROVIDED AS CONTINUOUS MEMBERS. (NO LAPS, USED AS A SINGLE CONTINUOUS BAR IN THE SLAB)
9. WEEP HOLES SHALL BE PLACED IN BACK WALL WITH FILTER FABRIC OR STONE ON BACK SIDE

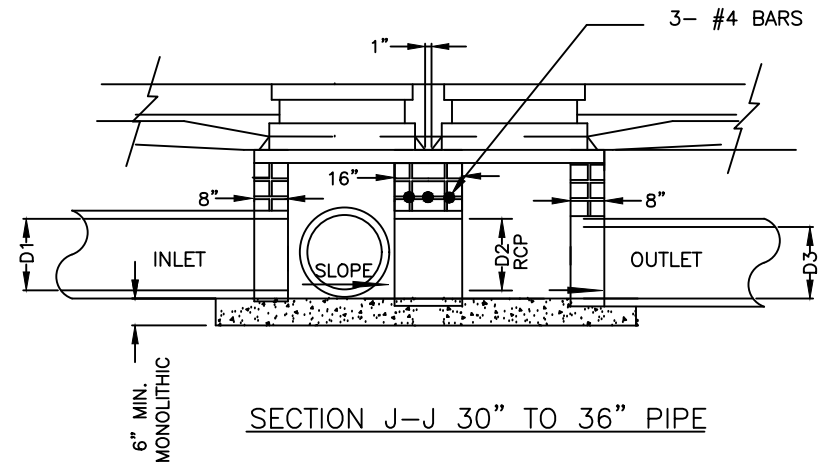
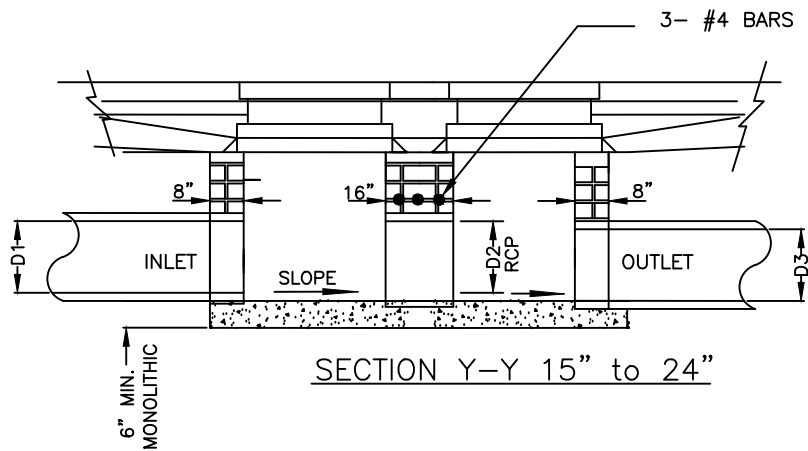
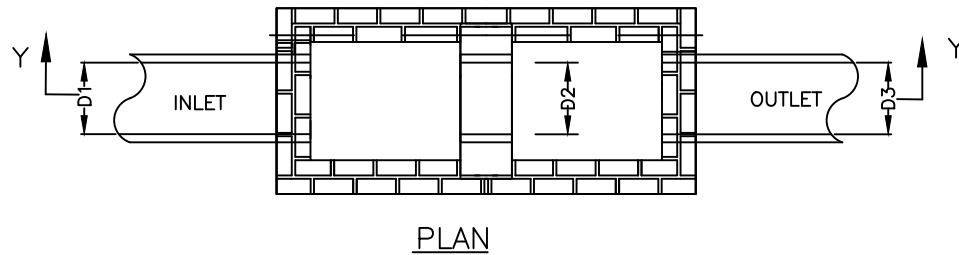
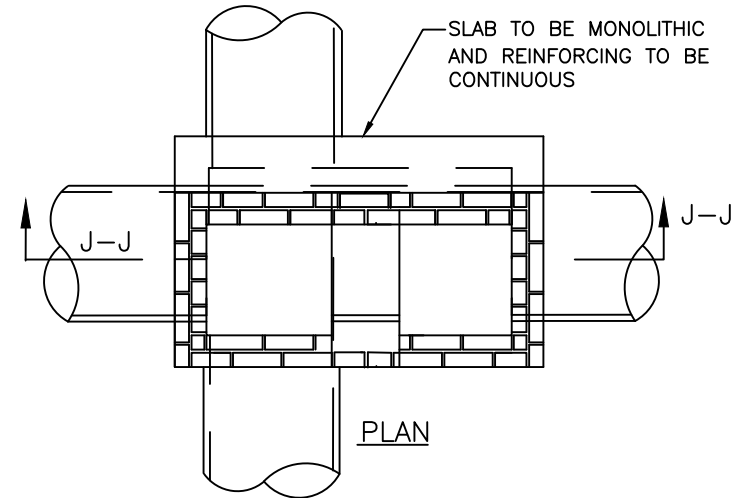

NOT TO SCALE



CITY OF CHARLOTTE
LAND DEVELOPMENT STANDARDS

BRICK DOUBLE CATCH BASIN
15" THRU 36" PIPE

STD. NO.	REV.
20.03	20

GENERAL NOTES:

1. MORTAR JOINTS SHOULD BE BETWEEN 3/8" AND 5/8" THICK.
2. ALL CONCRETE TO BE 3600 P.S.I COMPRESSIVE STRENGTH.
3. THE 6" OPENING SHOWN MAY BE INCREASED TO 8" MAX. IF DEEMED TO BE NECESSARY BY THE ENGINEER.
4. ALL CATCH BASIN OVER 3'-6" IN DEPTH SHALL BE PROVIDED WITH STEPS 1'-2" ON CENTERS. STEPS SHALL BE IN ACCORDANCE WITH STD. 20.12.
5. CONCRETE BRICK MAY BE USED IN LIEU OF HARD COMMON CLAY BRICK.
6. JUMBO BRICK WILL BE PERMITTED.
7. FOR 8'-0" IN HEIGHT OR LESS USE 8" WALL. OVER 8'-0" IN HEIGHT USE 12" WALL TO 6'-0" FROM TOP OF WALL, AND 8" WALL FOR THE REMAINING 6'-0".
8. ALL EXPOSED JOINTS WILL BE CONCAVE TOOLED.
9. ALL PIPE IN STORM DRAIN STRUCTURE SHALL BE STRUCK EVEN WITH THE INSIDE WALL, GROUTED AND BRUSHED SMOOTH.
10. WEEP HOLES SHALL BE PLACED IN BACK WALL WITH FILTER FABRIC OR STONE ON BACK SIDE.
11. THIS CATCH BASIN IS NOT TO BE USED WITHIN STREET RIGHT OF WAY UNLESS OTHERWISE APPROVED BY CITY ENGINEER.

DIMENSIONS OF BOX AND PIPE				REINFORCING					COVER DIMENSION	
PIPE	SPAN	WIDTH	HEIGHT	BARS - X		BARS - Y		TOTAL	F	G
D	A	B	H1(MIN)	NO.	LENGTH	NO.	LENGTH	LBS.		
15"	3'-6"	2'-3"	2'-7"	2	3'-4"	7	4'-7"	26	4'-10"	3'-7"
18"	4'-0"	2'-8"	2'-11"	2	3'-9"	8	5'-1"	33	5'-4"	4'-0"
24"	4'-0"	2'-8"	3'-5"	2	3'-9"	8	5'-1"	33	5'-4"	4'-0"
30"	4'-0"	3'-6"	3'-11"	2	4'-7"	9	5'-1"	37	5'-4"	4'-10"
36"	4'-0"	3'-6"	4'-6"	2	4'-7"	9	5'-1"	37	5'-4"	4'-10"
42"	4'-0"	3'-6"	4'-11"	2	4'-7"	9	5'-1"	37	5'-4"	4'-10"
48"	4'-6"	4'-0"	5'-5"	2	5'-1"	10	5'-7"	45	5'-10"	5'-4"

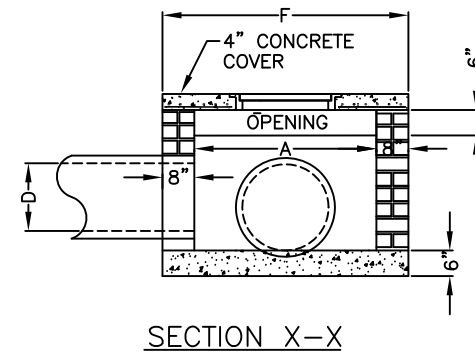
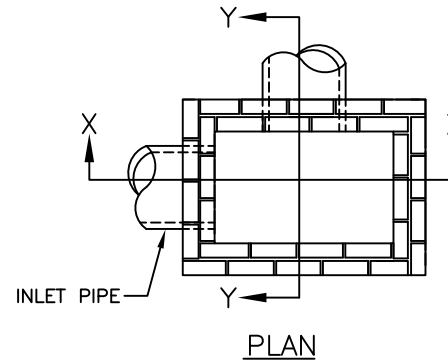
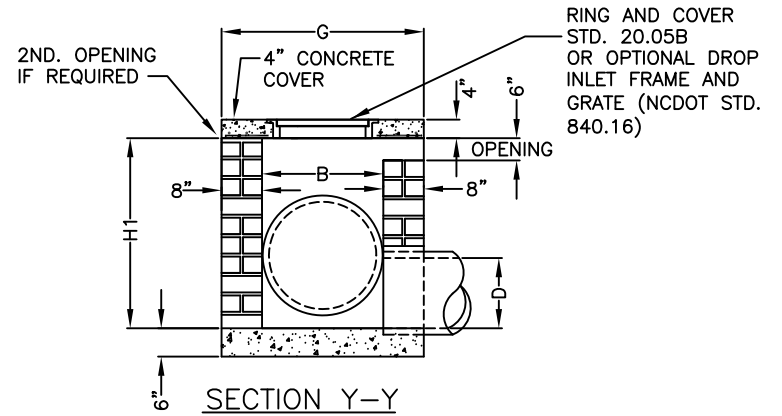

RING AND COVER
STD. 20.05B
OR OPTIONAL DROP
INLET FRAME AND
GRATE (NCDOT STD.
840.16)



CITY OF CHARLOTTE
LAND DEVELOPMENT STANDARDS
INCLUDES CHARLOTTE ETJ

SLAB TYPE CATCH BASIN
15" THRU 48" PIPE

STD. NO.	REV.
20.05A	7

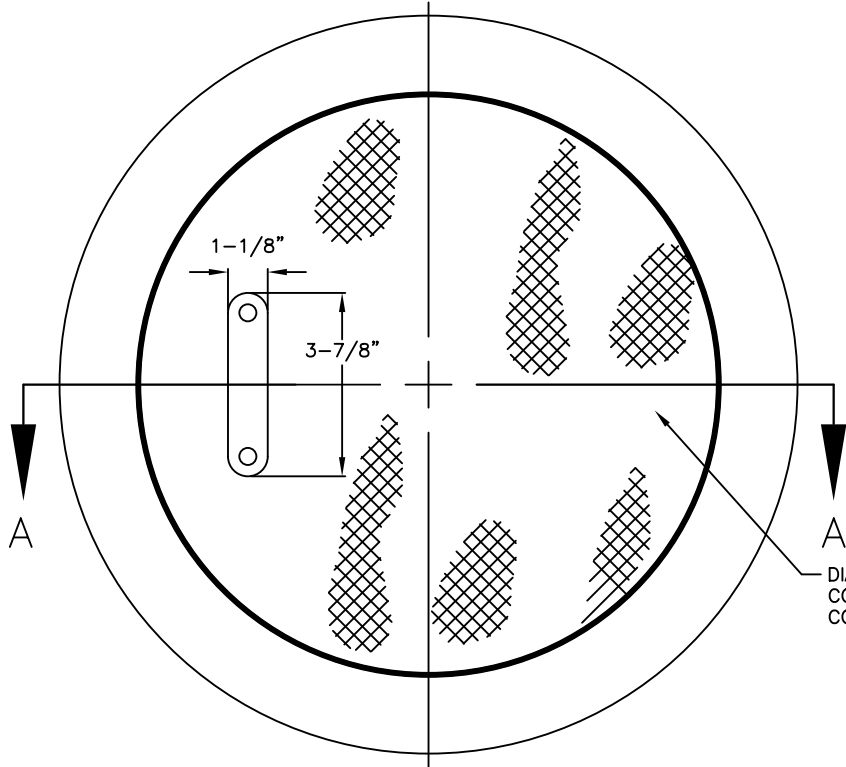

PLAN VIEW

MINIMUM WEIGHT	
RING	96 LBS
COVER	86 LBS

DIAMOND PATTERN SOLID
COVER OR ROUND GRATE
COVER

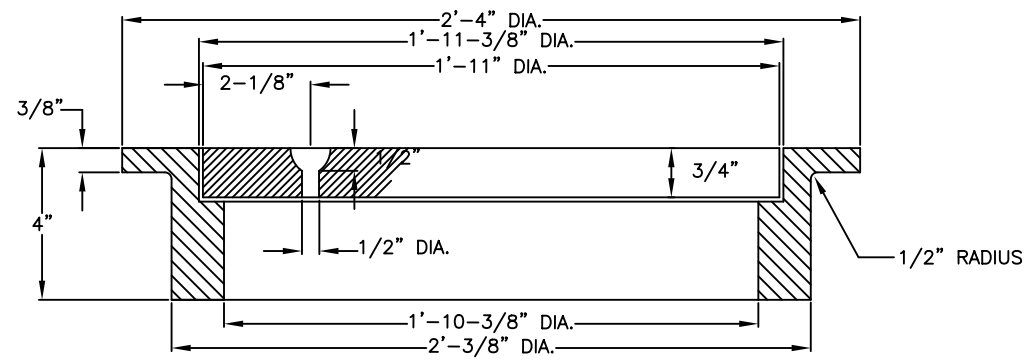

SECTION A-A



CITY OF CHARLOTTE
LAND DEVELOPMENT STANDARDS
INCLUDES CHARLOTTE ETJ

MANHOLE RING AND COVER
FOR SLAB TYPE CATCH BASIN

STD. NO.	REV.
20.05B	5

CONCRETE PIPE			DIMENSIONS										
WALL THK.	OUT DIA.	IN DIA.	H	A	B	C	E	F	G	W	K	M	
2 1/4"	19 1/2"	15"	27 1/2"	20"	24"	8"	7 1/2"	4"	4"	8"	17"	10"	
2 1/2"	23"	18"	31"	20"	24"	8"	9"	4"	4"	8"	17"	12"	
3"	30"	24"	38"	20"	30"	8"	12"	4"	4"	8"	21"	15"	
3 1/2"	37"	30"	45"	20"	44"	12"	15"	6"	8"	8"	31"	18"	
4"	44"	36"	52"	32"	44"	12"	18"	6"	8"	8"	31"	22"	
4 1/2"	51"	42"	59"	32"	48"	12"	21"	6"	8"	8"	34"	26"	
5"	58"	48"	66"	32"	48"	12"	24"	6"	8"	8"	34"	29"	
5 1/2"	65"	54"	73"	32"	54"	12"	27"	6"	8"	8"	38"	33"	
6"	72"	60"	80"	36"	66"	12"	30"	8"	12"	12"	46"	36"	
6 1/2"	79"	66"	87"	36"	72"	12"	33"	8"	12"	12"	51"	40"	
7"	86"	72"	94"	36"	78"	12"	36"	8"	12"	12"	56"	43"	

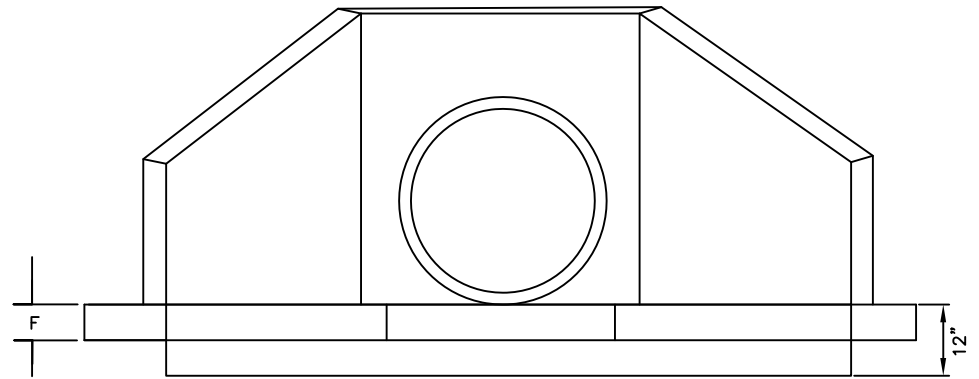

FRONT VIEW

REINFORCING					
DIA.	"C" BAR		"D" BAR		
	NO.	LGT.	NO.	LGT.	
15"	4	2'-0"	4	1'-11"	
18"	4	2'-3"	4	2'-2"	
24"	4	2'-9"	4	2'-8"	
30"	4	3'-3"	4	3'-2"	
36"	4	3'-9"	4	3'-8"	
42"	4	4'-3"	4	4'-2"	
48"	4	4'-9"	4	4'-8"	
54"	4	5'-3"	4	5'-2"	
60"	4	5'-9"	4	5'-8"	
66"	4	6'-3"	4	6'-2"	
72"	4	6'-9"	4	6'-8"	

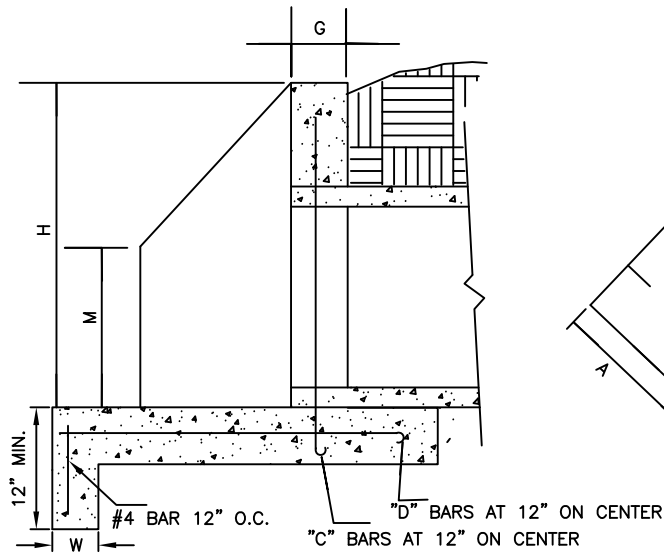

SIDE VIEW

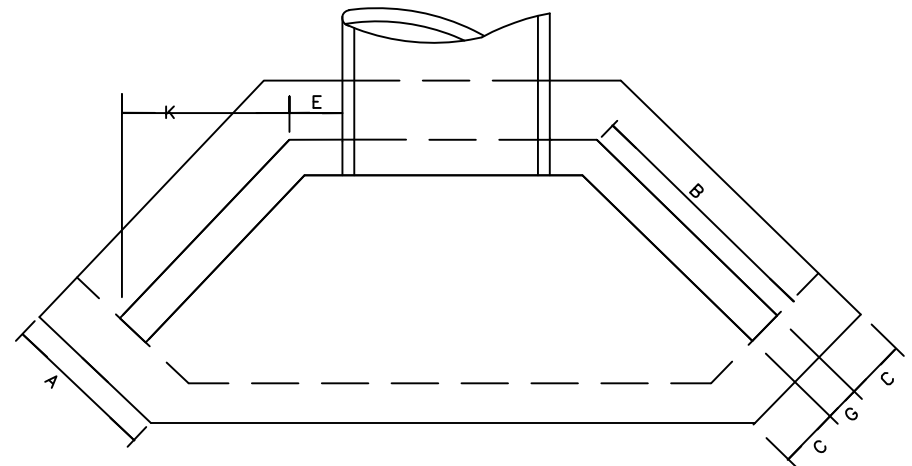

TOP VIEW

NOT TO SCALE



CITY OF CHARLOTTE
 LAND DEVELOPMENT STANDARDS
 INCLUDES CHARLOTTE ETJ

CONCRETE WINGWALL WITH SPLASH PAD

STD. NO.	REV.
20.17A	8

GENERAL NOTES:

1. ALL CORNERS TO BE CHAMFERED 1" IF CONCRETE.
2. THE CONTRACTOR WILL BE REQUIRED TO PLACE 2-#6 BARS "Y" IN THE TOP OF ALL ENDWALL FOR PIPE CULVERTS 42" AND OVER WITH A MINIMUM 3" COVER AND A LENGTH OF 6" LESS THAN ENDWALL.
3. FORMS ARE TO BE USED FOR THE CONSTRUCTION OF THE BOTTOM SLAB.
4. WALL THICKNESS (T) SHOWN IS NOT TO BE INTERPRETED TO MEAN THE THICKNESS ACCEPTABLE, BUT IS USED ONLY IN COMPUTING ENDWALL QUANTITIES.
5. IF CONTRACTOR ELECTS TO USE CONSTRUCTION JOINT AT BOTTOM OF PIPE, AND POURS BASE SEPARATELY, THE TOP OF BASE SHALL BE LEFT ROUGH.
6. ALL CONCRETE TO BE 3600 P.S.I COMPRESSIVE STRENGTH.

NOT TO SCALE



CITY OF CHARLOTTE
LAND DEVELOPMENT STANDARDS
INCLUDES CHARLOTTE ETJ

CONCRETE WINGWALL
WITH SPLASH PAD

STD. NO.	REV.
20.17B	

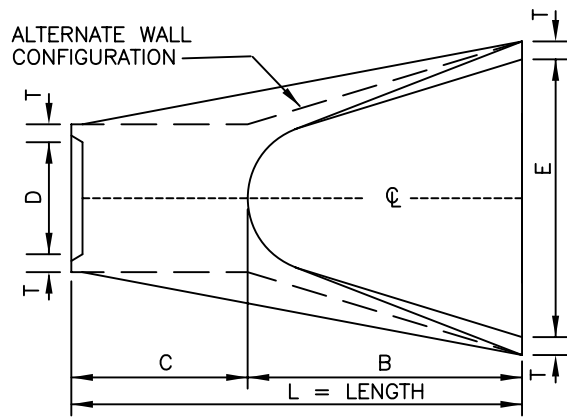

PLAN

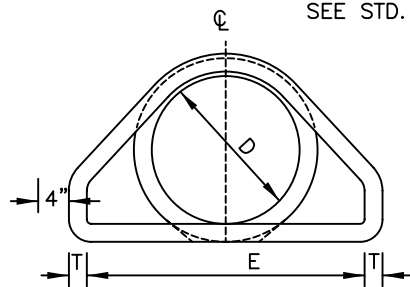
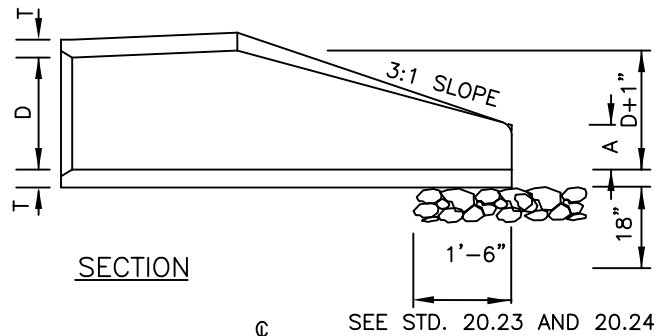

END VIEW

TABLE OF DIMENSIONS							
D	T	A	B	C	E	L	WT.
12"	2-1/4"	4"	2'-0"	4'-1"	2'-0"	6'-1"	730
15"	2-1/4"	6"	2'-3"	3'-10"	2'-0"	6'-1"	730
18"	2-1/2"	9"	2'-3"	3'-10"	3'-0"	6'-1"	1190
24"	3"	10"	3'-8"	2'-6"	4'-0"	6'-2"	1770
30"	3-1/2"	1'-0"	4'-6"	1'-8"	5'-0"	6'-2"	2380
36"	4"	1'-3"	5'-3"	2'-11"	6'-0"	8'-2"	5320
42"	4-1/2"	1'-9"	5'-3"	2'-11"	6'-6"	8'-2"	5920
48"	5"	2'-0"	6'-0"	2'-2"	7'-0"	8'-2"	7470
54"	5-1/2"	2'-3"	5'-6"	2'-10"	7'-6"	8'-4"	8810
60"	6"	2'-6"	5'-0"	3'-3"	8'-0"	8'-3"	11180
66"	6-1/2"	3'-0"	6'-0"	2'-3"	8'-6"	8'-3"	12530
72"	7"	3'-0"	6'-6"	1'-9"	9'-0"	8'-3"	13980

GENERAL NOTES:

1. SEE FORMER NCDOT STANDARD 310.01 FOR DETAILS.
2. REINFORCEMENT SHALL CONFORM TO THE REQUIREMENTS OF REINFORCED CONCRETE PIPE OF LIKE DIAMETER PER AASHTO M170, TABLE 2, WALL B.
3. ALL CONCRETE TO BE 3600 P.S.I COMPRESSIVE STRENGTH.
4. PROVIDE TONGUE OR SPIGOT JOINT AT INLET END SECTION.
5. PROVIDE GROOVE OR BELL JOINT AT OUTLET END SECTION.
6. THE DIMENSIONS FOR END SECTIONS SHALL SUBSTANTIALLY AGREE WITH THE TABLE. MINOR VARIATIONS WILL BE PERMITTED BASED ON THE MANUFACTURER'S STANDARD FORMS AND TEMPLATES.
7. NOT TO BE USED IN NCDOT MAINTAINED RIGHT OF WAY.

NOT TO SCALE



CITY OF CHARLOTTE
LAND DEVELOPMENT STANDARDS
INCLUDES CHARLOTTE ETJ

FLARED END SECTION
12" THRU 72" PIPE

STD. NO.	REV.
20.22	1

NOTES:

1. CLASS OR MEDIAN SIZE OF RIPRAP AND LENGTH, WIDTH AND DEPTH OF APRON TO BE DESIGNED BY THE ENGINEER.
2. REFER TO THE CHARLOTTE MECKLENBURG STORM WATER DESIGN MANUAL FOR RIPRAP APRON DESIGN STANDARDS.
3. RIPRAP SHOULD EXTEND UP BOTH SIDES OF THE APRON AND AROUND THE END OF THE PIPE OR CULVERT AT THE DISCHARGE OUTLET AT A MAXIMUM SLOPE OF 2:1 AND A HEIGHT NOT LESS THAN TWO THIRDS THE PIPE DIAMETER OR CULVERT HEIGHT.
4. THERE SHALL BE NO OVERFLOW FROM THE END OF THE APRON TO THE SURFACE OF THE RECEIVING CHANNEL. THE AREA TO BE PAVED OR RIPRAPPED SHALL BE UNDERCUT SO THAT THE INVERT OF THE APRON SHALL BE AT THE SAME GRADE (FLUSH) WITH THE SURFACE OF THE RECEIVING CHANNEL. THE APRON SHALL HAVE A CUTOFF OR TOE WALL AT THE DOWNSTREAM END.
5. THE WIDTH OF THE END OF THE APRON SHALL BE EQUAL TO THE BOTTOM WIDTH OF THE RECEIVING CHANNEL. MAXIMUM TAPER TO RECEIVING CHANNEL 5:1
6. ALL SUBGRADE FOR STRUCTURE TO BE COMPACTED TO 95% OR GREATER.
7. THE PLACING OF FILL, EITHER LOOSE OR COMPACTED IN THE RECEIVING CHANNEL SHALL NOT BE ALLOWED.
8. NO BENDS OR CURVES IN THE HORIZONTAL ALIGNMENT OF THE APRON WILL BE PERMITTED.
9. FILTER FABRIC SHALL BE INSTALLED ON COMPACTED SUBGRADE PRIOR TO PLACEMENT OF RIP RAP.
10. ANY DISTURBED AREA FROM END OF APRON TO RECEIVING CHANNEL MUST BE STABILIZED.

USE USDA NOMOGRAPH FROM NC SEDIMENT AND EROSION CONTROL MANUAL OR CHARLOTTE MECKLENBURG STORM WATER DESIGN MANUAL FOR DESIGN DATA.

OUTLET	La	W1	W2	*T	H

* d50 (see fig 8.06 a&b "NC SEDIMENT AND EROSION CONTROL MANUAL")
 dmax = 1.5 x d50
 T = 1.5 X dmax.
 T(min.)=10"

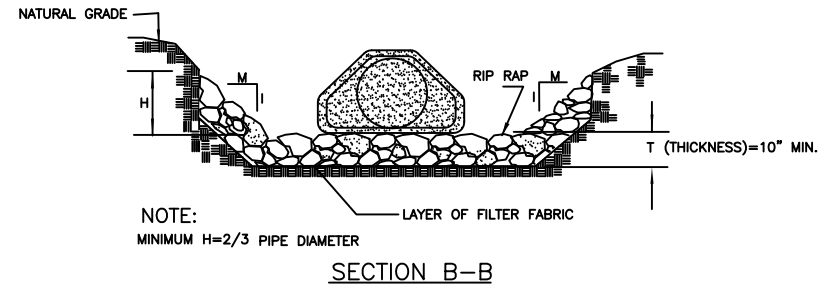
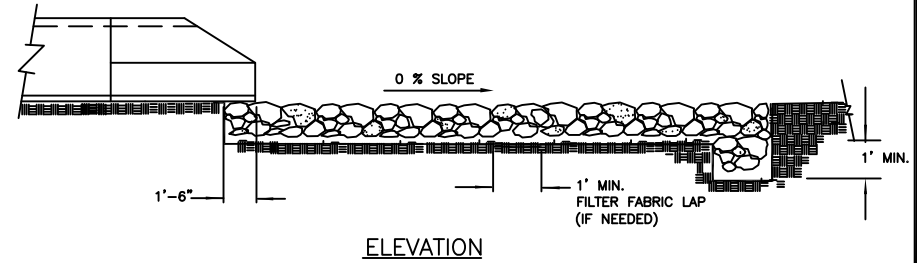
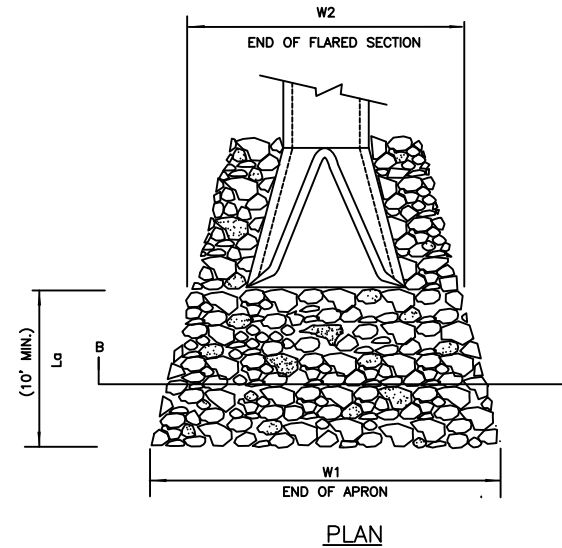

CITY OF CHARLOTTE
LAND DEVELOPMENT STANDARDS
 INCLUDES CHARLOTTE ETJ

RIPRAP APRON AT PIPE OUTFALLS
 OTHER THAN AT SWIM

STD. NO.	REV.
20.23	7

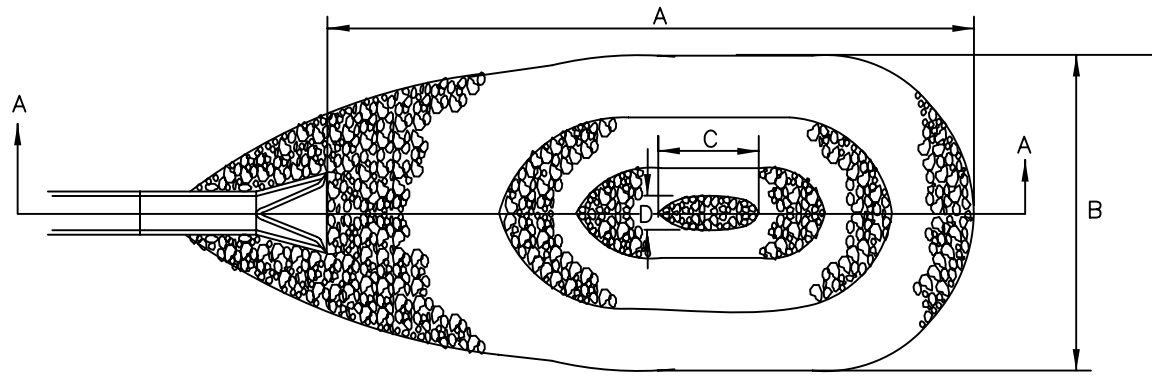

PLAN

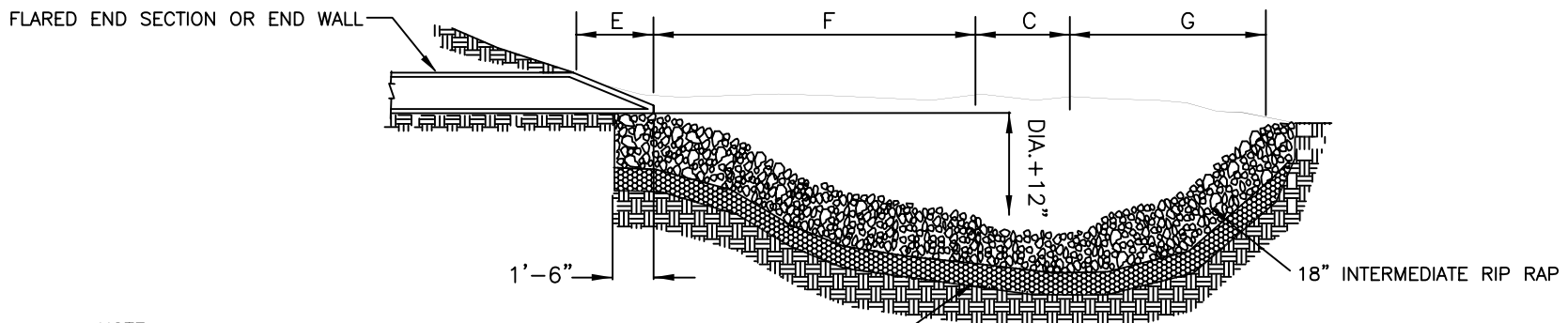

SECTION A-A

NOTE

1. THIS DETAIL IS TO ONLY BE USED WHEN
OUTFALL HAS A CONTINUOUS FLOW OF WATER AND
WITH PRIOR APPROVAL OF THE CITY ENGINEER.

PIPE SIZE	A	B	C	D	E	F	G	WT. RIP RAP IN TONS
15"	10'	7'	1 1/2'	1'	1'	4 1/2'	3'	6
18"	12'	8'	2'	1'	1'	5'	4'	8
21"	15'	9'	2 1/2'	1 1/2'	1'	7'	4 1/2'	12
24"	17'	10'	2 1/2'	1 1/2'	1'	8'	5 1/2'	15
30"	20'	13'	3'	2'	2'	9'	6'	22
36"	24'	16'	3 1/2'	2'	2'	9 1/2'	7'	33

NOT TO SCALE



CITY OF CHARLOTTE
LAND DEVELOPMENT STANDARDS
INCLUDES CHARLOTTE ETJ

RIP RAP PLUNGE POOL

STD. NO.	REV.
20.24	

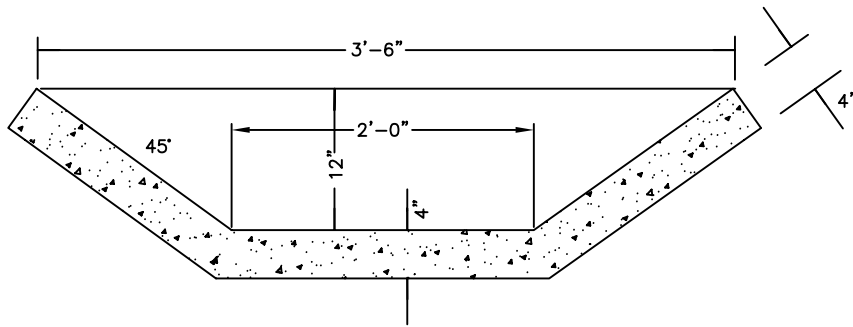

SLOPE DRAIN, BASE DITCH OR BERM DRAINAGE
OUTLET DITCH

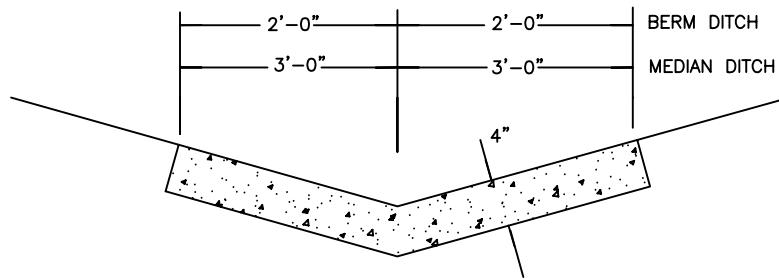

MEDIAN OR BERM DITCH

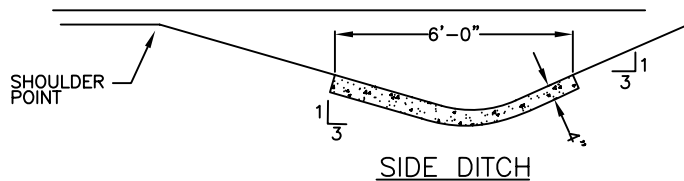

SIDE DITCH

GENERAL NOTES:

IN THE 4" CONCRETE PAVED DITCHES PLACE 1/2" EXPANSION JOINT AT 30 FT INTERVALS AND AT ALL OTHER POINTS WHERE PROPOSED DITCHES ABUT RIGID OBJECTS. PLACE GROOVED JOINTS 1" DEEP AT 10' INTERVALS BETWEEN EXPANSION JOINTS.

WIDTH AND SHAPE OF PROPOSED 4" CONCRETE PAVED DITCHES SHALL BE AS SHOWN OR AS DIRECTED BY THE ENGINEER.

ALL CONCRETE TO BE 3600 P.S.I. COMPRESSIVE STRENGTH.

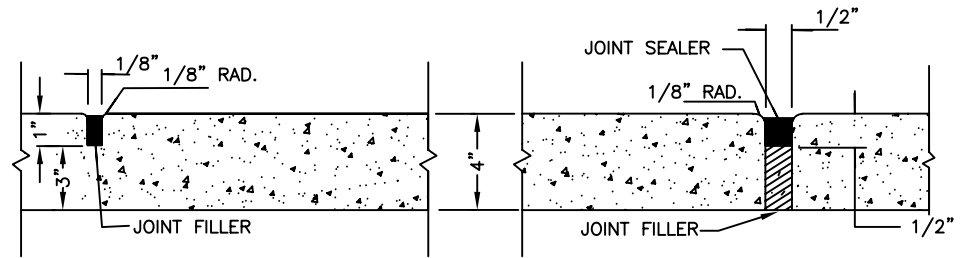

SHOWING GROOVED JOINT

SHOWING EXPANSION JOINT

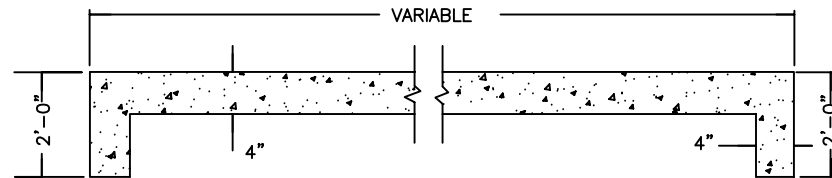

LONGITUDINAL SECTION OF PAVED DITCH

SHOWING 2'-0" CURTAIN WALL REQUIRED AT EACH END

NOT TO SCALE



**CITY OF CHARLOTTE
LAND DEVELOPMENT STANDARDS
INCLUDES CHARLOTTE ETJ**

CONCRETE PAVED DITCHES

STD. NO.	REV.
20.26	

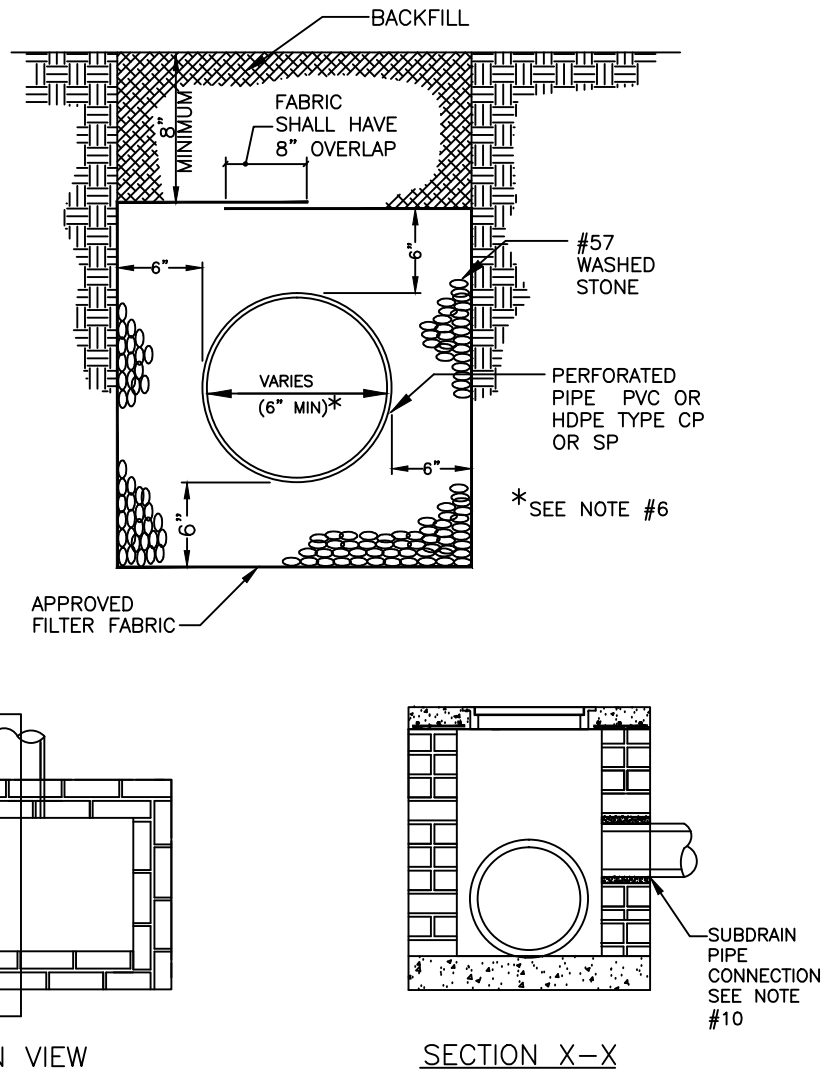

NOTES:

1. A MINIMUM OF 6" FROM OUTSIDE DIAMETER OF PIPE TO SIDE OF TRENCH MUST BE ALLOWED FOR WASHED STONE. THE METHOD OF COMPACTING BACKFILL MATERIAL IS SUBJECT TO APPROVAL BY THE CITY ENGINEER. AN APPROVED FILTER FABRIC SHALL BE PLACED AROUND STONE AND OVERLAPPED 8" AT TOP WITHIN STREET RIGHT OF WAY.
2. SUBDRAIN IS TO BE A MINIMUM 6" DIAMETER PERFORATED PIPE; USE SCHEDULE 40 PVC PER ASTM D1785 OR HDPE PER AASHTO M252, TYPE CP (SINGLE-WALL, CORRUGATED) OR TYPE SP (DOUBLE-WALL, SMOOTH INTERIOR).
3. OUTLET PIPE FROM SUBDRAIN SHALL BE NON-PERFORATED UNDER PAVEMENT (INCLUDING SIDEWALKS AND DRIVEWAYS). SEE SITE PLAN FOR SLOPE OF SUBDRAIN AND TIE IN TO STORM DRAINAGE.
4. THE OUTLET PIPES SHALL BE SCHEDULE 40 (MIN.) PVC PER ASTM D2665 OR HDPE PER AASHTO M252, TYPE S (DOUBLE WALL, SMOOTH INTERIOR) UNDER ROADWAYS.
5. FILTER FABRIC SHALL BE AN APPROVED, TYPE 2 WATER PERMEABLE, SYNTHETIC FABRIC.
6. A MINIMUM 4" DIAMETER SUBDRAIN MAY BE USED IN PLANTING AREAS AS DESCRIBED IN THE CLDSM 4000 SERIES.
7. CLEAN-OUTS ARE RECOMMENDED AT ALL PIPE INTERSECTIONS AND AT A 100' MAXIMUM SEPARATION.
8. SUBDRAIN INVERTS AT CATCH BASINS SHOULD BE INSTALLED ABOVE THE BOTTOM TO AVOID SURCHARGE OF SUBDRAIN SYSTEM.
9. ALL SUBDRAINS WILL TIE INTO A STANDARD DRAINAGE STRUCTURE OR DAYLIGHT TO THE SURFACE WHERE APPROPRIATE, AND NOT DIRECTLY INTO A PIPE.
10. ONLY REMOVE NECESSARY MASONRY UNITS TO INSTALL PIPE INTO BASIN WALL. PRECAST STRUCTURES WILL BE CORE DRILLED 2 INCHES LARGER THAN PIPE DIAMETER TO PROVIDE FOR INSTALLATION OF PIPE IN WALL.
11. ALL PIPE IN STORM DRAIN STRUCTURE SHALL BE STRUCK EVEN WITH THE INSIDE WALL, GROUTED AND BRUSHED SMOOTH.
12. PIPE INSTALLATION PER SECTION 300 NCDOT STANDARD SPECIFICATIONS FOR ROADS AND STRUCTURES.
13. SUBDRAINS WILL BE INSTALLED AT A DRAINAGE STRUCTURE AND THIS CONNECTION WILL NEED TO BE INSPECTED BY CITY STAFF PRIOR TO BACKFILLING.
14. SCHEDULE 40 PVC (NON-PERFORATED) SHALL BE USED TO MAKE THE CONNECTION TO THE STORM DRAINAGE SYSTEM. CONNECTION WILL BE WITHIN THE RIGHT-OF-WAY UNLESS OTHERWISE APPROVED BY THE CITY ENGINEER.
15. PREFABRICATED DRAINAGE MAY BE USED WITH APPROVAL OF CITY ENGINEER.
16. MAXIMUM OF TWO SUBDRAIN PENETRATIONS PER WALL OF DRAINAGE STRUCTURE.

CONNECTION AT DRAINAGE STRUCTURE

NOTE: STRUCTURE SHOWN FOR REPRESENTATION PURPOSES ONLY.



CITY OF CHARLOTTE
LAND DEVELOPMENT STANDARDS
 INCLUDES CHARLOTTE ETJ

SUBDRAIN DETAIL

STD. NO.	REV.
20.28	12

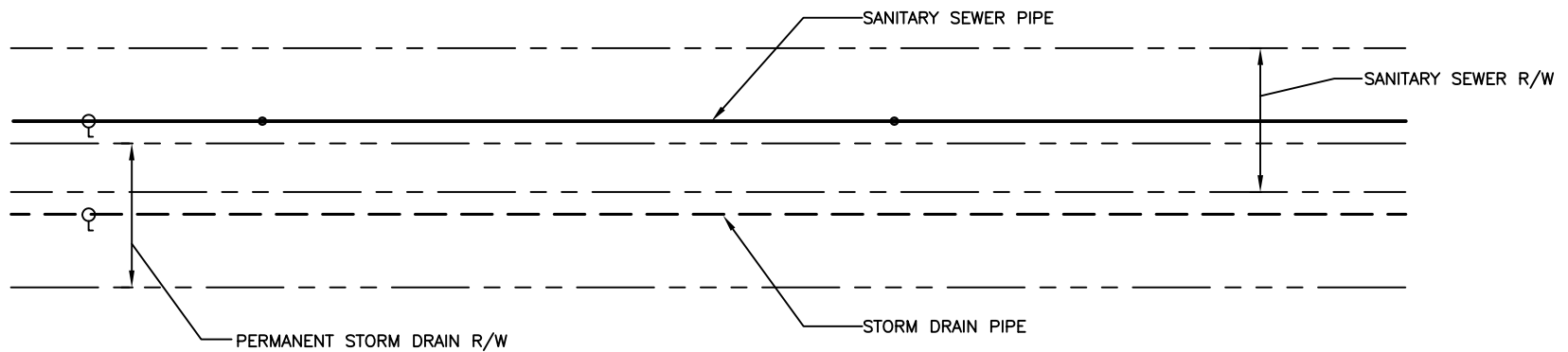

THE SANITARY SEWER AND STORM DRAINAGE RIGHTS OF WAY MAY OVERLAP; HOWEVER THE PIPE AND ASSOCIATED STRUCTURES MUST NOT BE IN THE OTHER UTILITY'S RIGHT OF WAY. THE SANITARY SEWER RIGHT OF WAY WIDTHS SHALL BE AS OUTLINED IN C.M.U.D.'S DESIGN MANUAL. THIS DETAIL DOES NOT APPLY TO STORM DRAINAGE UTILIZING OPEN CHANNEL FLOW.

PLAN VIEW

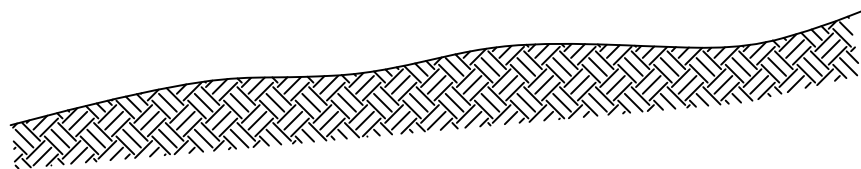

THE VERTICAL SEPARATION GUIDELINE WILL BE USED UP TO THE POINT WHERE THE TWO RIGHTS OF WAY ADJOIN EACH OTHER.

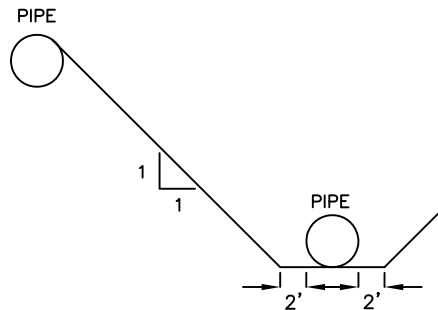

THE SANITARY SEWER AND STORM DRAINAGE PIPES MUST BE NO CLOSER TOGETHER HORIZONTALLY THAN THE VERTICAL DISTANCE BETWEEN THE TOP OF THE HIGHER PIPE AND THE BOTTOM OF THE LOWER PIPE. A MAINTENANCE CREW MUST BE ABLE TO DIG DOWN TO THE LOWER PIPE SLOPING THE DITCH ON A 1:1 SLOPE UP FROM THE REQUIRED TRENCH BOTTOM WIDTH AND NOT EXPOSE THE HIGHER PIPE.

PROFILE VIEW

NOT TO SCALE



**CITY OF CHARLOTTE
LAND DEVELOPMENT STANDARDS**
INCLUDES CHARLOTTE ETJ

OVERLAPPING STORM DRAINAGE/SANITARY
SEWER EASEMENTS

STD. NO.	REV.
20.29	9

GENERAL NOTES:

1. FOR STREAMS CARRYING 500 ACRES OR MORE OF SURFACE RUNOFF, THE EASEMENT REQUIREMENT IS TO BE THE WIDTH OF THE STREAM FROM TOP OF BANK TO TOP OF BANK, PLUS (+)10' ON EACH SIDE OF STREAM. (40' MINIMUM WIDTH)
2. FOR OPEN CHANNELS THE MINIMUM EASEMENT MUST CONTAIN THE WIDTH OF THE STREAM FROM TOP OF BANK TO TOP BANK.
3. WIDER EASEMENT WIDTHS MAY BE REQUIRED FOR PIPE DEPTHS GREATER THAN TEN FEET.
4. PIPE SYSTEMS AND OPEN CHANNELS ON PRIVATE PROPERTY SHALL BE PLACED IN A STORM DRAINAGE EASEMENT.
5. PIPE SYSTEMS SHALL TYPICALLY BE PLACED ALONG THE CENTERLINE OF THE STORM DRAINAGE EASEMENT
6. WHERE DUAL PIPES ARE PROPOSED, 1/2 OF THE STANDARD WIDTH FOR THE RESPECTIVE PIPE SIZE SHALL BE OFFSET FROM THE CENTERLINE OF EACH BARREL.

Easement Requirements for
Open Storm Drainage Channels

Area in Acreage	Easement Requirement
0-45 ac.	20'
45-120 ac.	30'
120-500 ac.	40'
500 ac.+	see note

Easement Requirements for Storm Drain Pipe

Pipe Size	Easement Requirement
15"	15'
18"	15'
24"	15'
30"	20'
36"	20'
42"	25'
48"	25'
54"+	30'MIN (VARIES)

NOT TO SCALE



CITY OF CHARLOTTE
LAND DEVELOPMENT STANDARDS
INCLUDES CHARLOTTE ETJ

MINIMUM DRAINAGE EASEMENT
REQUIREMENTS FOR STORM DRAIN PIPES
AND OPEN CHANNELS

STD. NO.	REV.
20.30	24

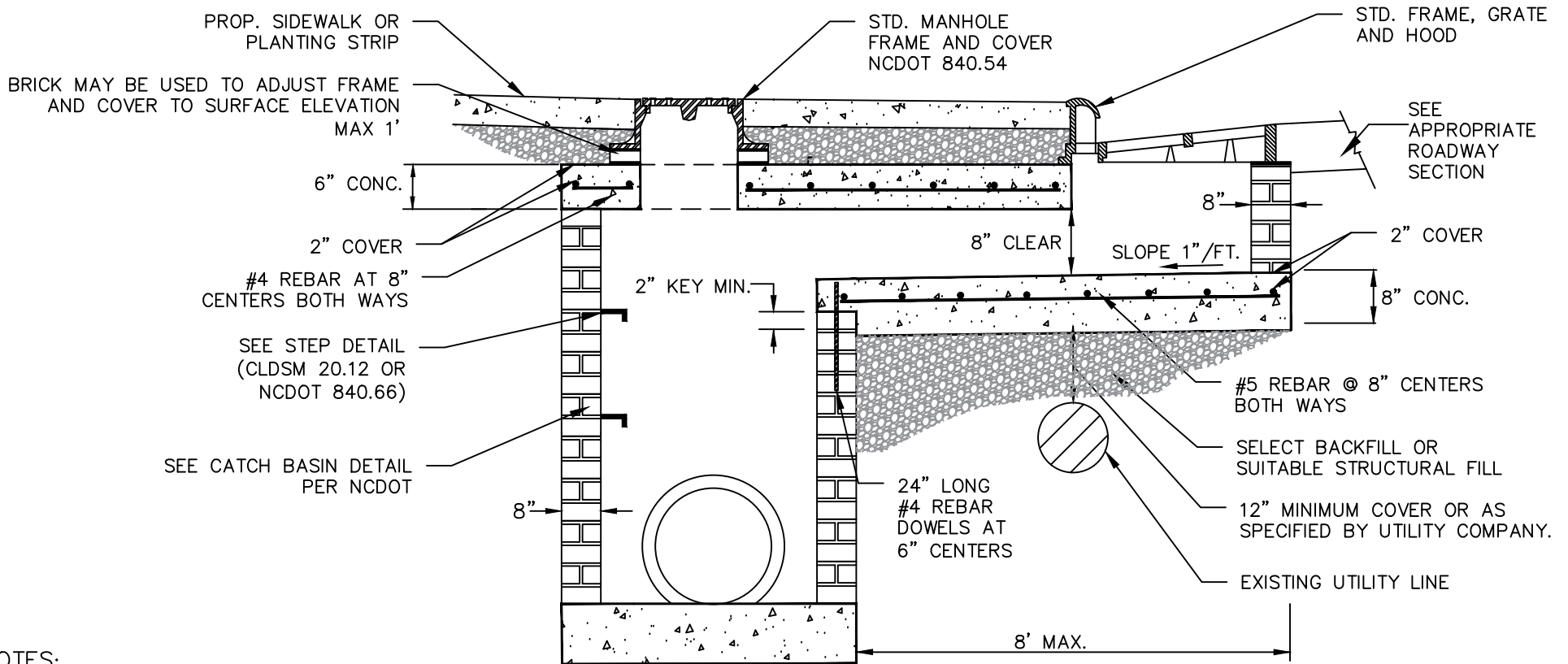

NOTES:

1. PRIOR APPROVAL FROM THE CITY ENGINEER IS REQUIRED FOR USE.
2. THIS STRUCTURE IS TO ONLY BE USED ON CITY MAINTAINED STREETS AND ONLY ON NCDOT-MAINTAINED STREETS WITH SPECIAL NCDOT PERMISSION.
3. SEE NCDOT DETAIL 840.01 FOR MAXIMUM PIPE SIZE ALLOWABLE

OFFSET CATCH BASIN
FOR USE W/ EXISTING UTILITY CONFLICT

NOT TO SCALE



CITY OF CHARLOTTE
LAND DEVELOPMENT STANDARDS
INCLUDES CHARLOTTE ETJ

OFFSET CATCH BASIN

STD. NO.	REV.
20.34	19

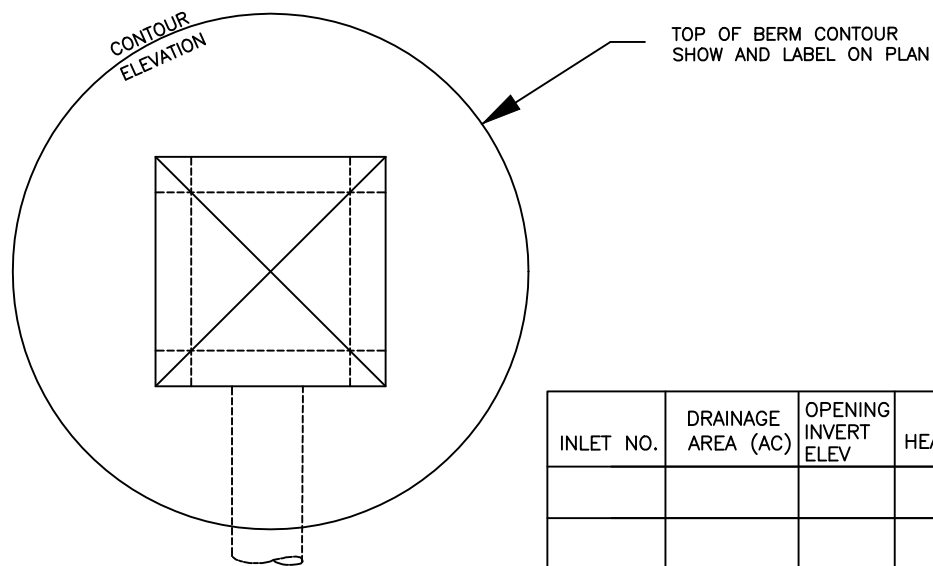
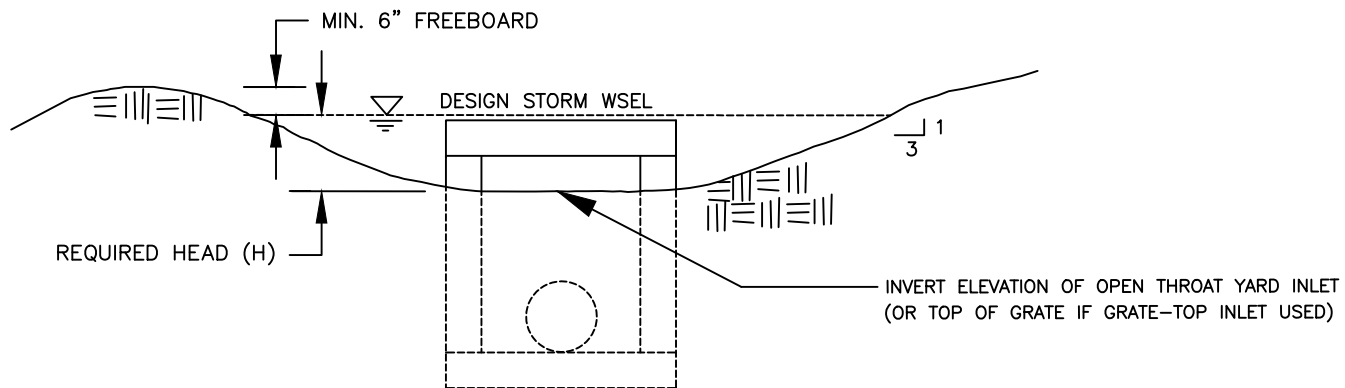

INLET NO.	DRAINAGE AREA (AC)	OPENING INVERT ELEV	HEAD H (FT)	TOP OF BERM ELEV.	FREE-BOARD (FT)	COMMENT



CITY OF CHARLOTTE
 LAND DEVELOPMENT STANDARDS
 INCLUDES CHARLOTTE ETJ

GRADING AT YARD/DROP INLET

NOT TO SCALE

STD. NO.	REV.
20.35	17

NOTES:

1. ALL BIORETENTION SHALL HAVE A MINIMUM 20 FOOT ACCESS EASEMENT CONNECTING TO A DEDICATED PUBLIC RIGHT OF WAY. ACCESS ROAD SHALL HAVE MIN. 12' STABILIZED WIDTH, MAX. LONG. GRADE OF 15%, MAX. CROSS-SLOPE 5%.
2. ALL DRAINAGE AREAS TO A BIORETENTION FACILITY ARE TO BE STABILIZED PRIOR TO INSTALLATION OF AMENDED SOILS, MULCH OR PLANTINGS.
3. AMENDED SOIL WILL ONLY BE PERMITTED WITH A VALID SOIL ANALYSIS REPORT.
4. INSTALL WIRE SCREENING AROUND ALL OUTLET OPENINGS TO PREVENT LOSS OF MULCH.
5. PLANTING PLAN REQUIREMENTS:
 - A. SODDED BIORETENTION CELLS ONLY:
USE NON-CLUMPING DEEP ROOTED SPECIES
 - B. VEGETATION OTHER THAN SOD:
AFTER 5 YEARS OF PLANTING PLANTING PLAN SHOULD ACHIEVE MIN. OF 75% OF PLANT COVERAGE. MAX COVERAGE WITH TREE OR SHRUB CANOPY IS 50%.

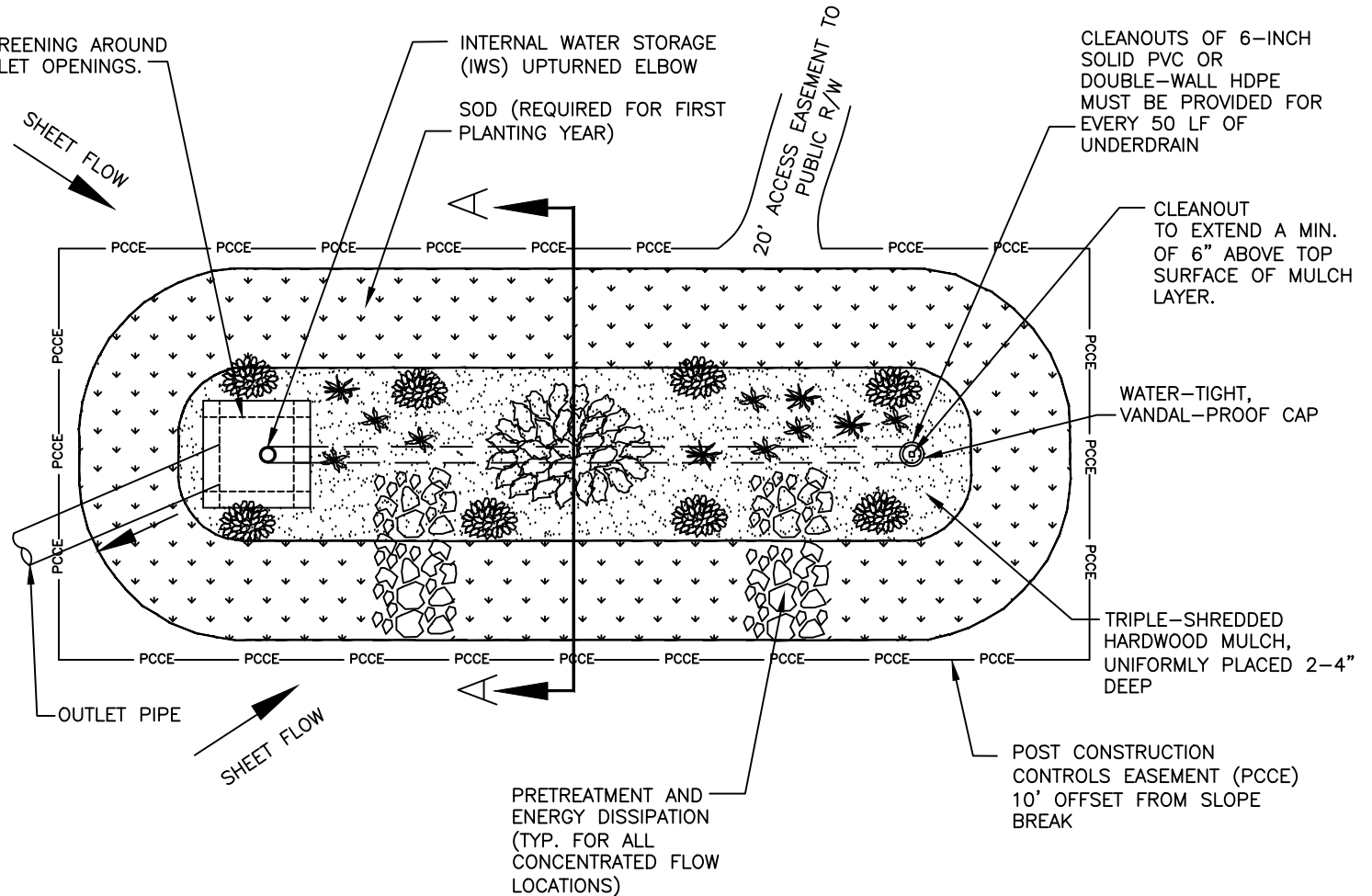

NOT TO SCALE



**CITY OF CHARLOTTE
LAND DEVELOPMENT STANDARDS**
INCLUDES CHARLOTTE ETJ

BIORETENTION PLAN

STD. NO.	REV.
21.00	24

NOTES:

1. ALL BIORETENTION FACILITIES SHALL HAVE A MINIMUM 20 FOOT ACCESS EASEMENT CONNECTING TO A DEDICATED PUBLIC RIGHT OF WAY. ACCESS ROAD SHALL HAVE MIN. 12' STABILIZED WIDTH, MAX. LONG. GRADE OF 15%, MAX. CROSS-SLOPE 5%.
2. ALL DRAINAGE AREAS TO A BIORETENTION FACILITY ARE TO BE STABILIZED PRIOR TO INSTALLATION OF AMENDED SOILS, MULCH OR PLANTINGS.
3. AMENDED SOIL WILL ONLY BE PERMITTED WITH A VALID SOIL ANALYSIS REPORT. NO AMENDED SOIL SHALL BE ALLOWED ON THE SIDE SLOPES.
4. INSTALL WIRE SCREENING AROUND ALL OUTLET OPENINGS TO PREVENT LOSS OF MULCH.
5. PVC UNDERDRAIN PIPE SHOULD HAVE 3/8" PERFORATIONS SPACED AT 6" CENTERS, MIN. 4 HOLES PER ROW. MAX SPACING OF UNDERDRAIN PIPE IS 10 FEET ON CENTER. HDPE SHALL ADHERE TO AASHTO M252 SPECS.
6. UNDERDRAIN CLEANOUTS SHOULD EXTEND A MIN. OF 6" ABOVE TOP SURFACE OF MULCH LAYER.
7. ONLY SMALL MATURING TREES ARE ALLOWED TO BE PLANTED IN THE AMENDED SOILS.
8. THE MINIMUM DEPTH OF THE MEDIA DEPENDS ON THE DESIGN OF THE CELL AS FOLLOWS:
 - A. ALL CELLS WITH TREES AND SHRUBS: 36 INCHES
 - B. CELLS WITHOUT TREES AND SHRUBS:
 - WITH NO INTERNAL WATER STORAGE: 24 INCHES
 - WITH INTERNAL WATER STORAGE: 30 INCHES
9. **MEDIA SPECIFICATION** - HOMOGENEOUS SOIL MIX ENGINEERED MEDIA BLEND WITH APPROXIMATE VOLUMES OF:
 - A) 75-85% MEDIUM TO COARSE WASHED SAND (ASTM C33, AASHTO M 6/M 80, ASTM C330, AASHTO M195, OR THE EQUIVALENT);
 - B) 8-15% FINES (SILT AND CLAY); AND
 - C) 5-10% ORGANIC MATTER (SUCH AS PINE BARK FINES).

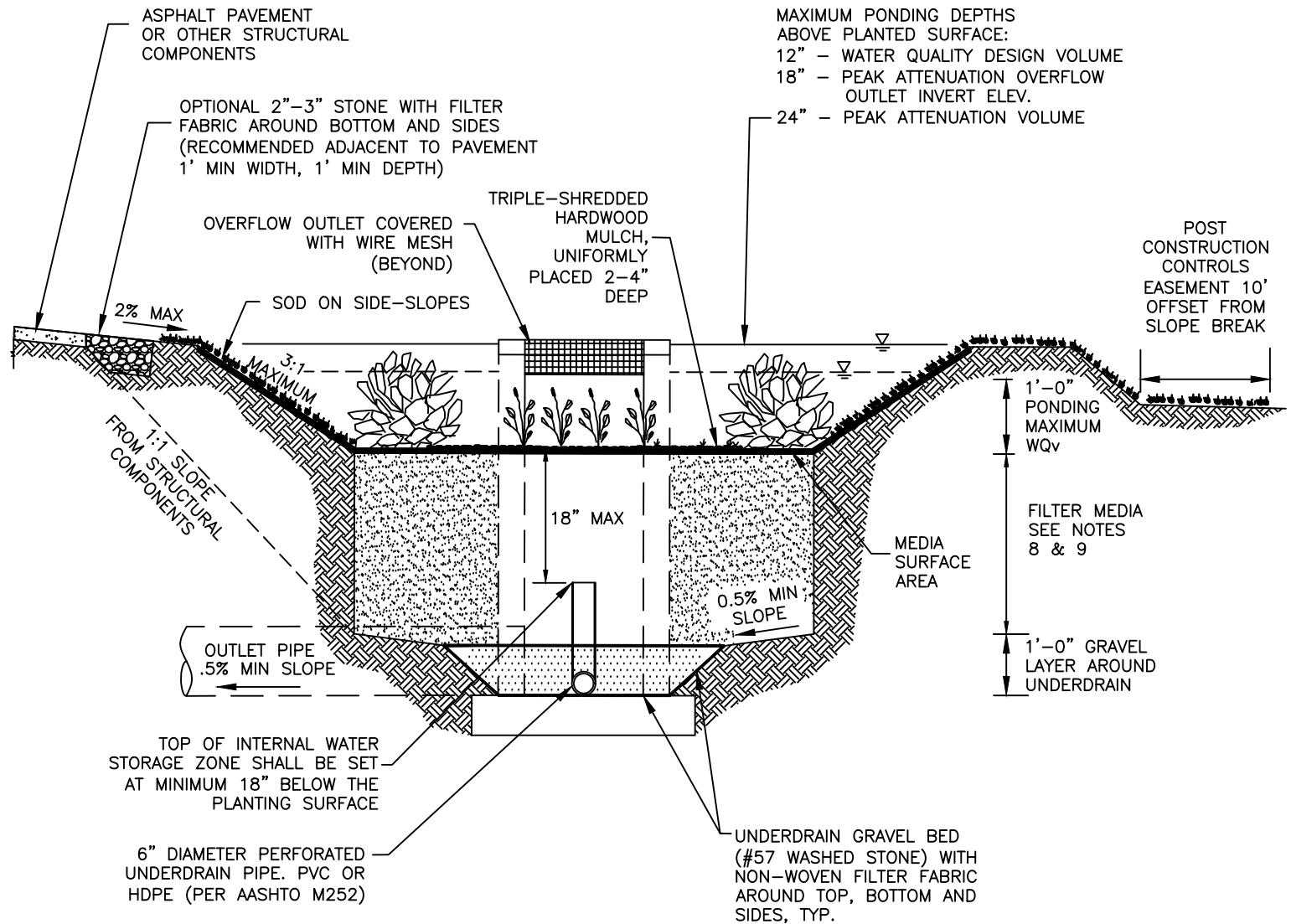

SECTION A-A

NOT TO SCALE



**CITY OF CHARLOTTE
 LAND DEVELOPMENT STANDARDS**
 INCLUDES CHARLOTTE ETJ

BIORETENTION CROSS-SECTION

STD. NO.	REV.
21.01	24

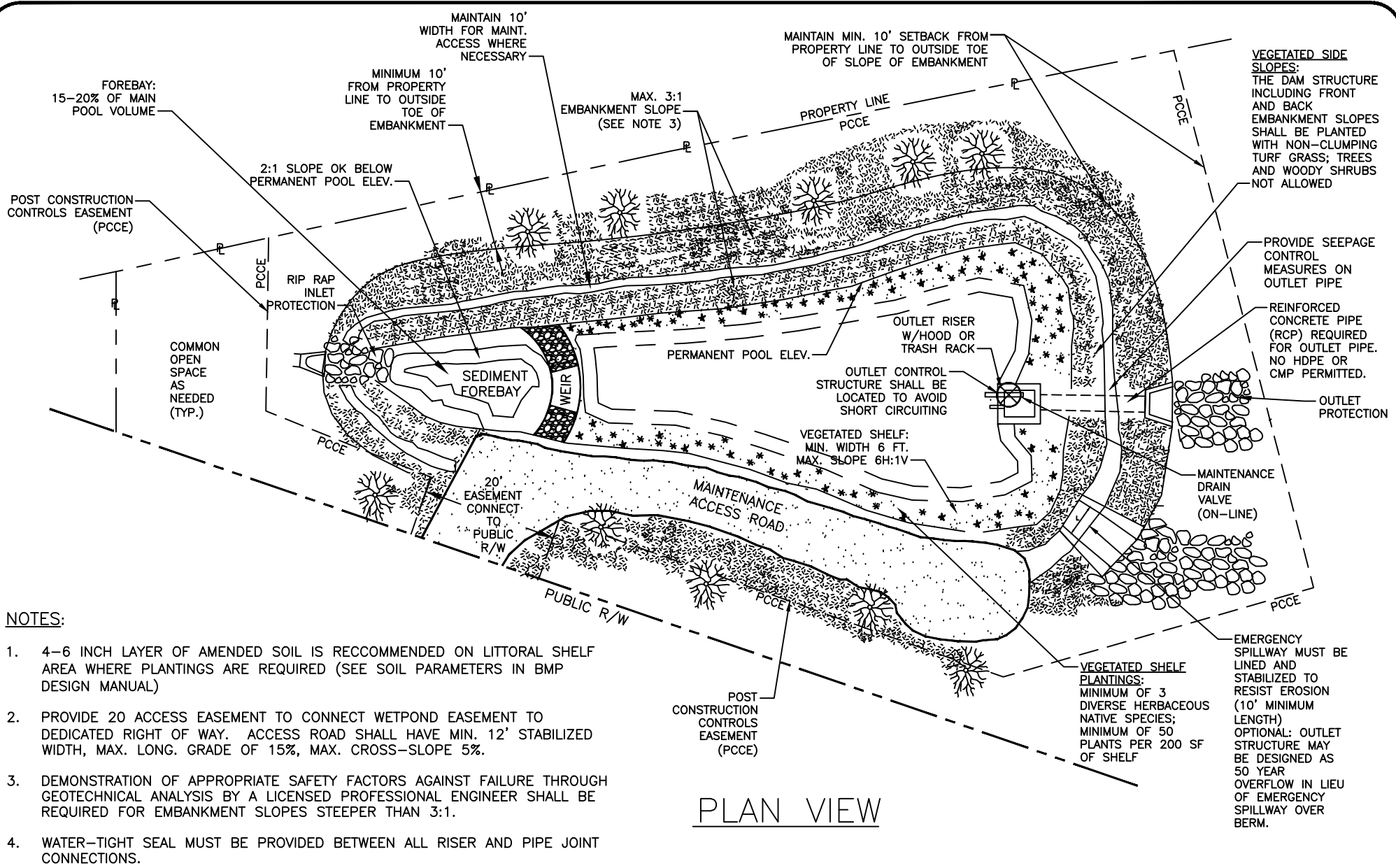

NOTES:

1. 4-6 INCH LAYER OF AMENDED SOIL IS RECCOMENDED ON LITTORAL SHELF AREA WHERE PLANTINGS ARE REQUIRED (SEE SOIL PARAMETERS IN BMP DESIGN MANUAL)
2. PROVIDE 20 ACCESS EASEMENT TO CONNECT WETPOND EASEMENT TO DEDICATED RIGHT OF WAY. ACCESS ROAD SHALL HAVE MIN. 12' STABILIZED WIDTH, MAX. LONG. GRADE OF 15%, MAX. CROSS-SLOPE 5%.
3. DEMONSTRATION OF APPROPRIATE SAFETY FACTORS AGAINST FAILURE THROUGH GEOTECHNICAL ANALYSIS BY A LICENSED PROFESSIONAL ENGINEER SHALL BE REQUIRED FOR EMBANKMENT SLOPES STEEPER THAN 3:1.
4. WATER-TIGHT SEAL MUST BE PROVIDED BETWEEN ALL RISER AND PIPE JOINT CONNECTIONS.

PLAN VIEW

NOT TO SCALE



**CITY OF CHARLOTTE
LAND DEVELOPMENT STANDARDS**
INCLUDES CHARLOTTE ETJ

WETPOND PLAN

STD. NO.	REV.
21.05	24

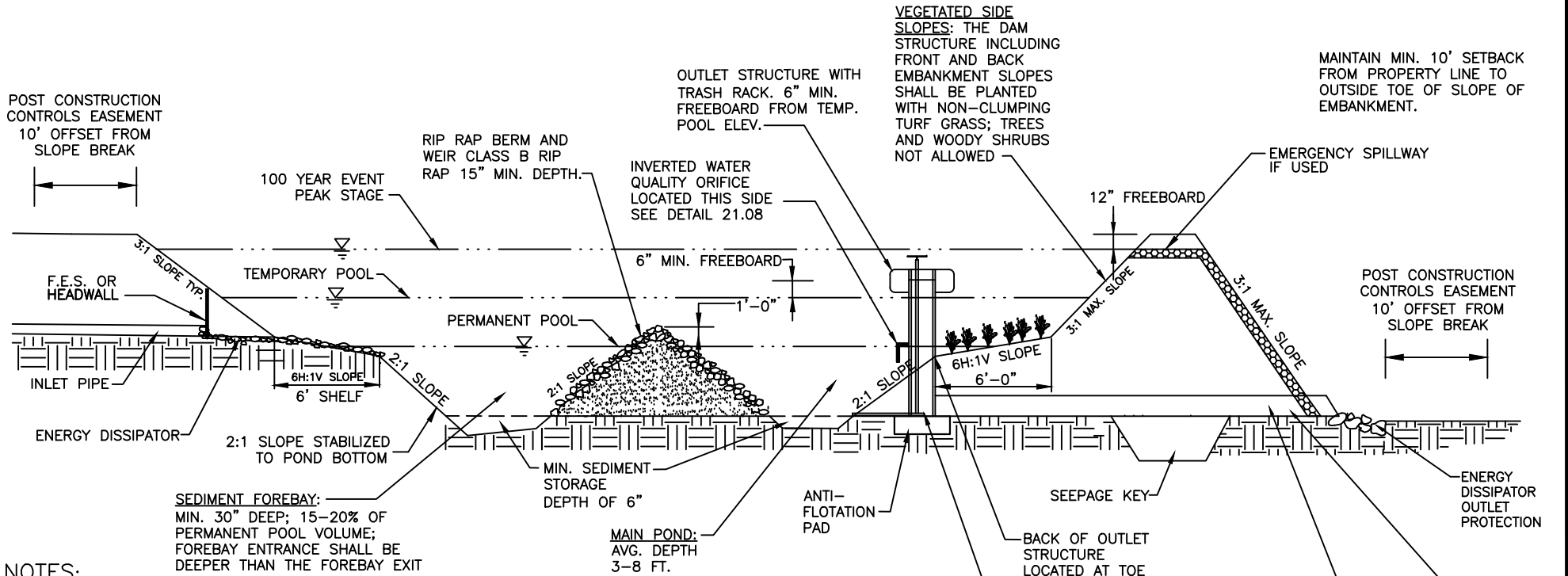

NOTES:

1. 4-6 INCH LAYER OF AMENDED SOIL IS RECCOMENDED ON LITTORAL SHELF AREA WHERE PLANTINGS ARE REQUIRED (SEE SOIL PARAMETERS IN SCM DESIGN MANUAL)
2. PROVIDE 20 ACCESS EASEMENT TO CONNECT WETPOND EASEMENT TO DEDICATED RIGHT OF WAY. ACCESS ROAD SHALL HAVE MIN. 12' STABILIZED WIDTH, MAX. LONG. GRADE OF 15%, MAX. CROSS-SLOPE 5%.
3. DEMONSTRATION OF APPROPRIATE SAFETY FACTORS AGAINST FAILURE THROUGH GEOTECHNICAL ANALYSIS BY A LICENSED PROFESSIONAL ENGINEER SHALL BE REQUIRED FOR EMBANKMENT SLOPES STEEPER THAN 3:1.
4. WATER-TIGHT SEAL MUST BE PROVIDED BETWEEN ALL RISER AND PIPE JOINT CONNECTIONS.

NOT TO SCALE



**CITY OF CHARLOTTE
LAND DEVELOPMENT STANDARDS**
INCLUDES CHARLOTTE ETJ

WETPOND PROFILE

STD. NO.	REV.
21.06	24

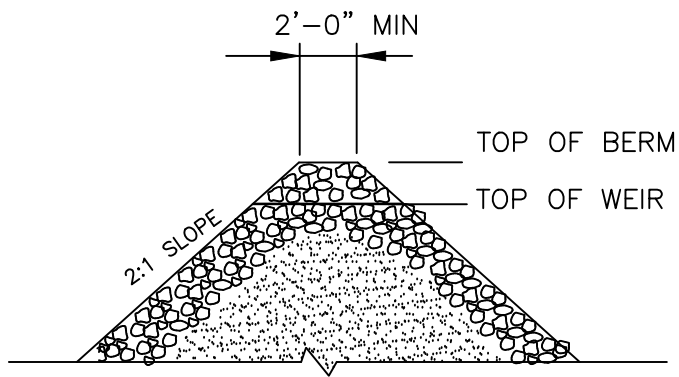

FOREBAY BERM AND WEIR SECTION

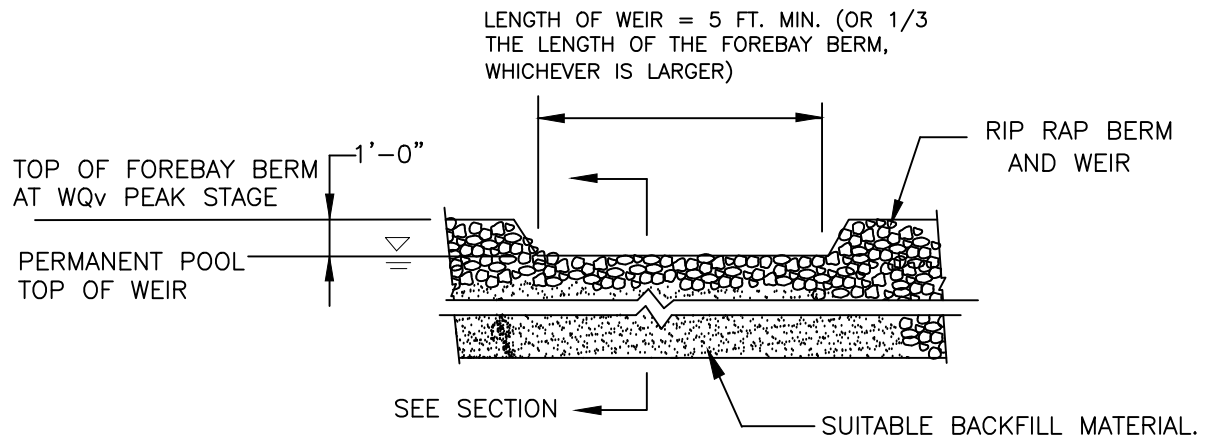

FOREBAY BERM AND WEIR DETAIL

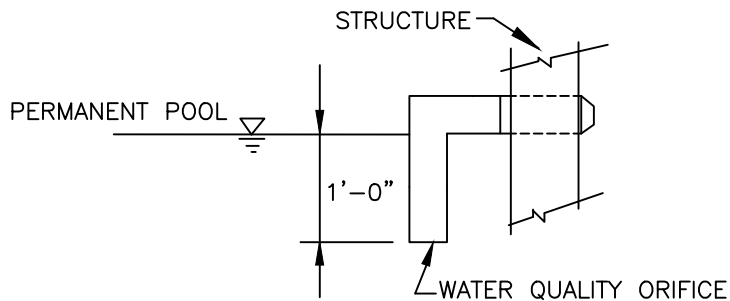

WATER QUALITY ORIFICE DETAIL

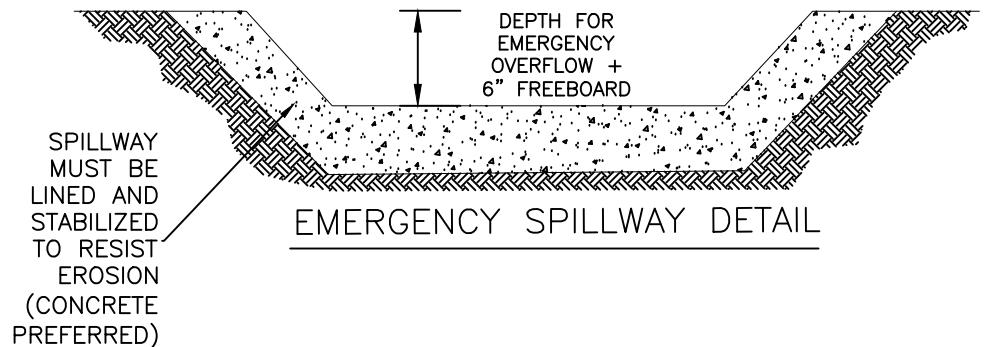

NOT TO SCALE



CITY OF CHARLOTTE
LAND DEVELOPMENT STANDARDS
INCLUDES CHARLOTTE ETJ

WETPOND
DETAILS

STD. NO.	REV.
21.08	20

NOTES:

1. THE PH, COMPACTION, AND OTHER ATTRIBUTES OF THE FIRST 12" DEPTH OF SOIL SHALL BE ADJUSTED IF NECESSARY TO PROMOTE PLANT ESTABLISHMENT AND GROWTH. (SEE SOIL PARAMETERS IN SCM DESIGN MANUAL)
2. PROVIDE 20' ACCESS EASEMENT TO CONNECT WETLAND EASEMENT TO DEDICATED RIGHT OF WAY.
3. ALL WETLANDS SHALL HAVE A MINIMUM 20 FOOT ACCESS EASEMENT CONNECTING TO A DEDICATED PUBLIC RIGHT OF WAY. ACCESS ROAD SHALL HAVE MIN. 12' STABILIZED WIDTH, MAX. LONG. GRADE OF 15%, MAX. CROSS-SLOPE 5%.
3. DEMONSTRATION OF APPROPRIATE SAFETY FACTORS AGAINST FAILURE THROUGH GEOTECHNICAL ANALYSIS BY A LICENSED PROFESSIONAL ENGINEER SHALL BE REQUIRED FOR EMBANKMENT SLOPES STEEPER THAN 3:1.
4. WATER-TIGHT SEAL MUST BE PROVIDED BETWEEN ALL RISER AND PIPE JOINT CONNECTIONS.

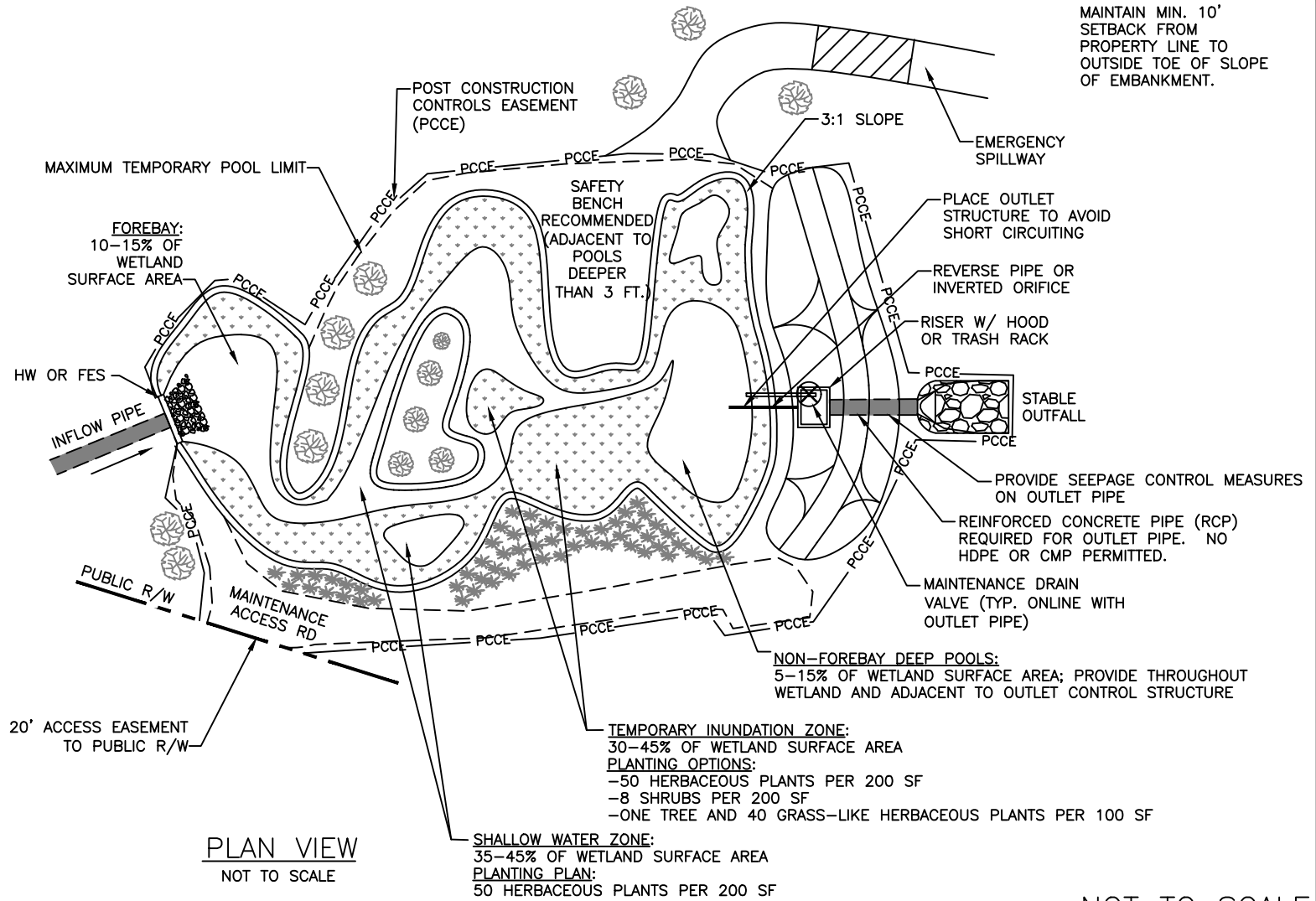

MAINTAIN MIN. 10' SETBACK FROM PROPERTY LINE TO OUTSIDE TOE OF SLOPE OF EMBANKMENT.

NOT TO SCALE



**CITY OF CHARLOTTE
LAND DEVELOPMENT STANDARDS**
INCLUDES CHARLOTTE ETJ

WETLAND PLAN

STD. NO.	REV.
21.10	24

POST CONSTRUCTION
CONTROLS EASEMENT
10' OFFSET FROM
SLOPE BREAK

TEMPORARY INUNDATION ZONE:
DRAW DOWN BETWEEN 2-5 DAYS;
WETLAND MAY TEMPORARILY POND
PEAK ATTENUATION VOLUME AT A
DEPTH EXCEEDING 15";
DEPTH = 0-15" ABOVE
PERMANENT POOL ELEV.

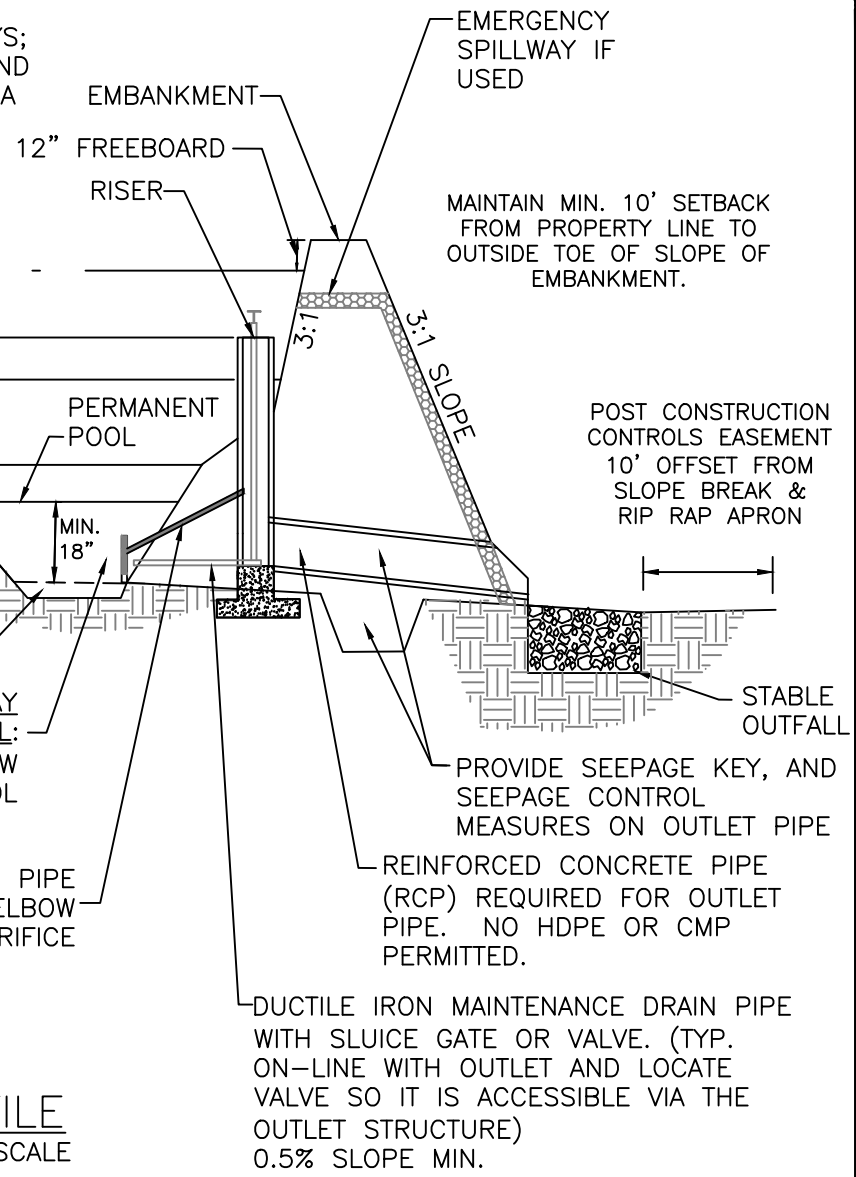

FOREBAY:
MIN 24-40" DEEP
SEDIMENT STORAGE

SHALLOW WATER ZONE:
DEPTH 0-9" BELOW
PERMANENT POOL

NON-FOREBAY
DEEP POOL:
DEPTH MIN. 18" BELOW
PERMANENT POOL

REVERSE PIPE
OR PVC ELBOW
WATER QUALITY ORIFICE

EMERGENCY
SPILLWAY IF
USED

POST CONSTRUCTION
CONTROLS EASEMENT
10' OFFSET FROM
SLOPE BREAK &
RIP RAP APRON

PROVIDE SEEPAGE KEY, AND
SEEPAGE CONTROL
MEASURES ON OUTLET PIPE

REINFORCED CONCRETE PIPE
(RCP) REQUIRED FOR OUTLET
PIPE. NO HDPE OR CMP
PERMITTED.

DUCTILE IRON MAINTENANCE DRAIN PIPE
WITH SLUICE GATE OR VALVE. (TYP.
ON-LINE WITH OUTLET AND LOCATE
VALVE SO IT IS ACCESSIBLE VIA THE
OUTLET STRUCTURE)
0.5% SLOPE MIN.

PROFILE
NOT TO SCALE

NOT TO SCALE

NOTES:

1. THE PH, COMPACTION, AND OTHER ATTRIBUTES OF THE FIRST 12" DEPTH OF SOIL SHALL BE ADJUSTED IF NECESSARY TO PROMOTE PLAN ESTABLISHMENT AND GROWTH. (SEE SOIL PARAMETERS IN SCM DESIGN MANUAL)
2. DEMONSTRATION OF APPROPRIATE SAFETY FACTORS AGAINST FAILURE THROUGH GEOTECHNICAL ANALYSIS BY A LICENSED PROFESSIONAL ENGINEER SHALL BE REQUIRED FOR EMBANKMENT SLOPES STEEPER THAN 3:1.
3. WATER-TIGHT SEAL MUST BE PROVIDED BETWEEN ALL RISER AND PIPE JOINT CONNECTIONS.



CITY OF CHARLOTTE
LAND DEVELOPMENT STANDARDS
INCLUDES CHARLOTTE ETJ

WETLAND PROFILE

STD. NO.	REV.
21.11	24

SPILLWAY
MUST BE
LINED AND
STABILIZED
TO RESIST
EROSION
(CONCRETE
PREFERRED)

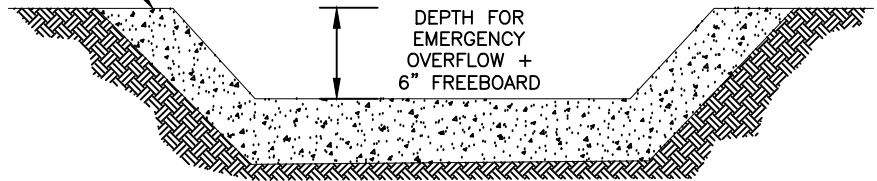

DEPTH FOR
EMERGENCY
OVERFLOW +
6" FREEBOARD

EMERGENCY SPILLWAY DETAIL

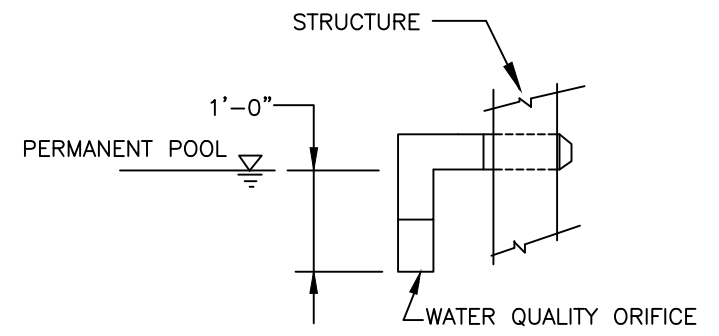

WATER QUALITY ORIFICE DETAIL

NOT TO SCALE



CITY OF CHARLOTTE
LAND DEVELOPMENT STANDARDS
INCLUDES CHARLOTTE ETJ

WETLAND DETAILS

STD. NO.	REV.
21.13	18

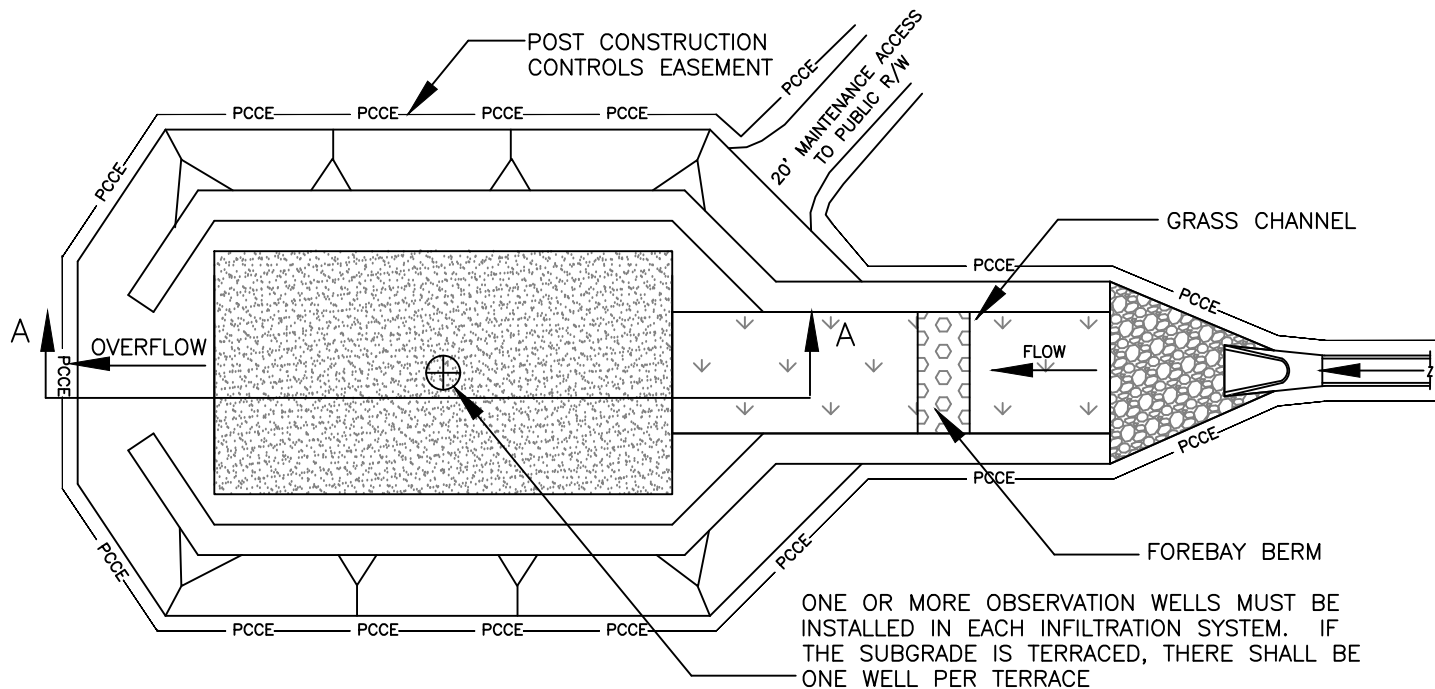

ONE OR MORE OBSERVATION WELLS MUST BE INSTALLED IN EACH INFILTRATION SYSTEM. IF THE SUBGRADE IS TERRACED, THERE SHALL BE ONE WELL PER TERRACE

PLAN
NOT TO SCALE

NOTES:

1. CONNECT INFILTRATION TRENCH EASEMENT TO A DEDICATED PUBLIC RIGHT OF WAY WITH A 20-FOOT ACCESS EASEMENT.
2. LINE THE SIDES AND TOP OF THE TRENCH WITH AN APPROPRIATE GEOTEXTILE FILTER FABRIC THAT PREVENTS SOIL PIPING BUT HAS GREATER PERMEABILITY THAN THE PARENT SOIL. THE TOP LAYER OF THE FILTER FABRIC IS SPACED 2-6 INCHES FROM THE TOP OF THE SYSTEM AND SERVES TO PREVENT SEDIMENT FROM PASSING INTO THE STONE AGGREGATE.

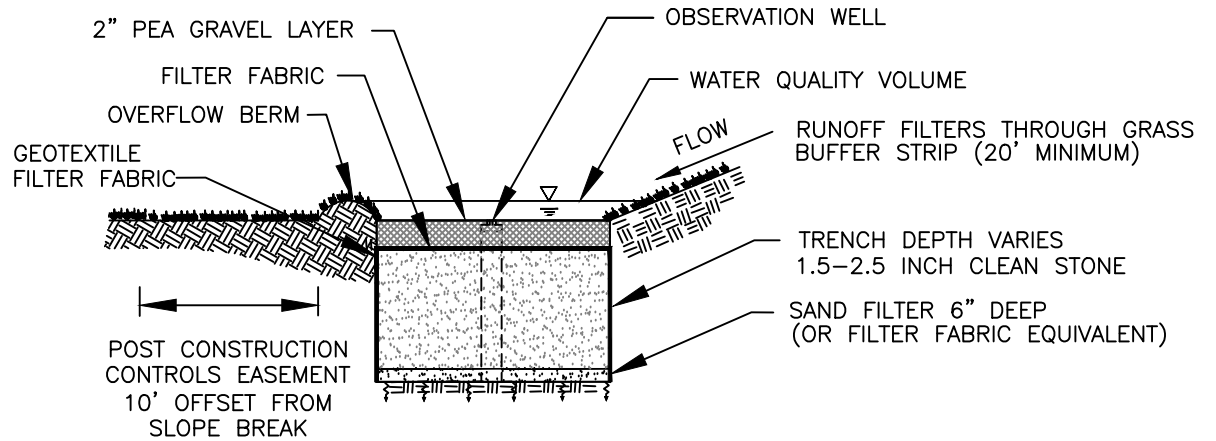

SECTION A-A
NOT TO SCALE

NOT TO SCALE



CITY OF CHARLOTTE
LAND DEVELOPMENT STANDARDS
INCLUDES CHARLOTTE ETJ

INFILTRATION TRENCH

STD. NO.	REV.
21.19	24

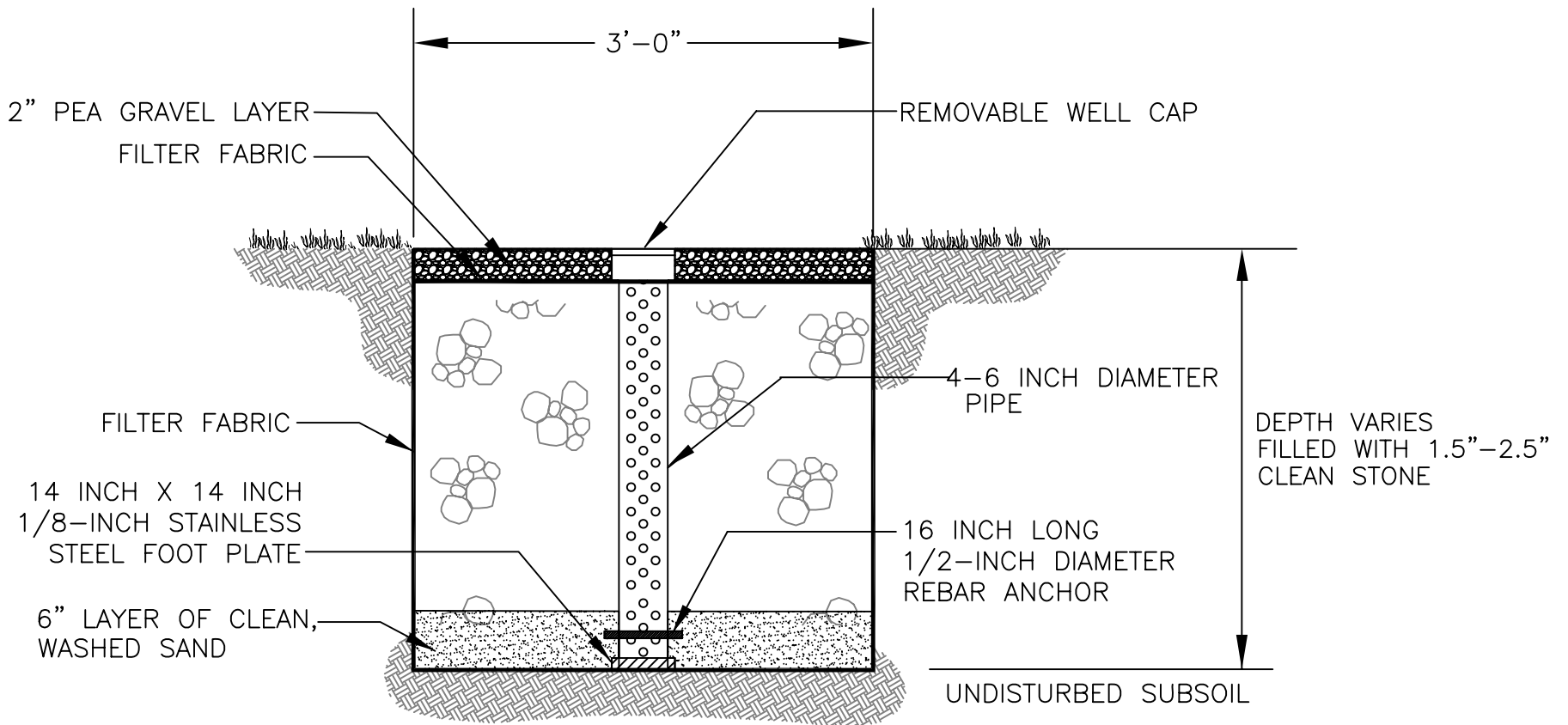

PERFORATION HOLES TO BE 1/2 INCH DIAMETER
AT 3 INCH MINIMUM VERTICAL SPACING

NOT TO SCALE



CITY OF CHARLOTTE
LAND DEVELOPMENT STANDARDS
INCLUDES CHARLOTTE ETJ

OBSERVATION WELL
BMP FIG. 4.6.3

STD. NO.	REV.
21.20	2

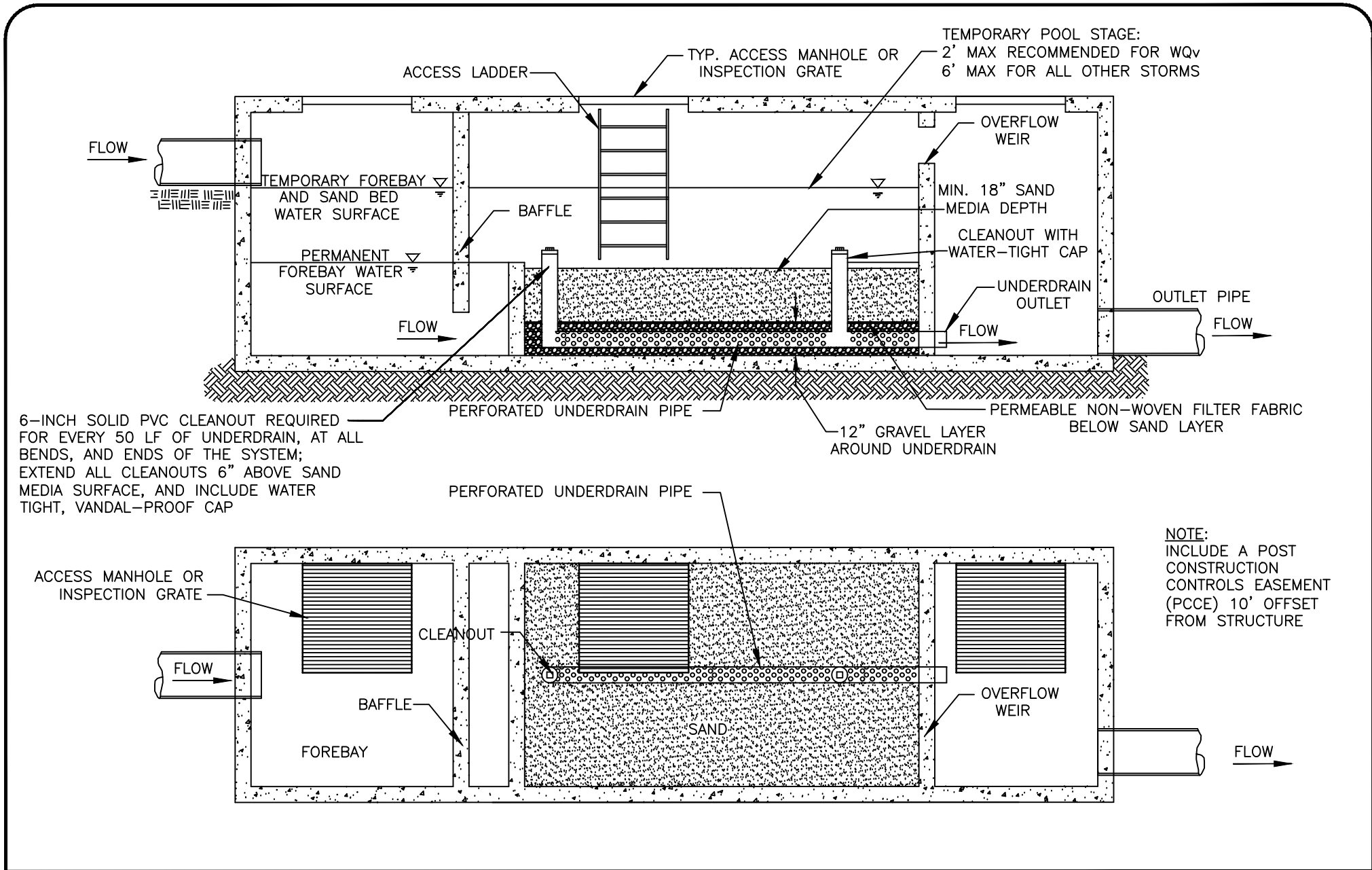

CITY OF CHARLOTTE
LAND DEVELOPMENT STANDARDS
INCLUDES CHARLOTTE ETJ

UNDERGROUND SAND FILTER

STD. NO.	REV.
21.23	24

NOTES:

1. ALL SAND FILTERS SHALL HAVE A MINIMUM 20 FOOT ACCESS EASEMENT CONNECTING TO A DEDICATED PUBLIC RIGHT OF WAY. ACCESS ROAD SHALL HAVE MIN. 12' STABILIZED WIDTH, MAX. LONG. GRADE OF 15%, MAX. CROSS-SLOPE 5%. IN ADDITION, A 10-FOOT WIDE PERMANENT MAINTENANCE ACCESS EASEMENT MUST BE PROVIDED AROUND THE PERIMETER OF ALL BMPs TO ALLOW FOR ADEQUATE MAINTENANCE AND REPAIR.
2. ALL DRAINAGE AREAS TO A SAND FILTER FACILITY ARE TO BE STABILIZED PRIOR TO INSTALLATION OF SAND.
3. CLEAN OUTS IN THE UNDERDRAIN SYSTEM ARE TO BE PROVIDED EVERY 50' MINIMUM, AT ALL BENDS, AND ENDS OF THE SYSTEM FOR MAINTENANCE PURPOSES. CLEAN OUTS SHALL HAVE WATER TIGHT, VANDAL-PROOF CAPS AND EXTEND 6" ABOVE THE SURFACE.
4. DEMONSTRATION OF APPROPRIATE SAFETY FACTORS AGAINST FAILURE THROUGH GEOTECHNICAL ANALYSIS BY A LICENSED PROFESSIONAL ENGINEER SHALL BE REQUIRED FOR EMBANKMENT SLOPES STEEPER THAN 3:1.
5. WATER-TIGHT SEAL MUST BE PROVIDED BETWEEN ALL RISER AND PIPE JOINT CONNECTIONS.

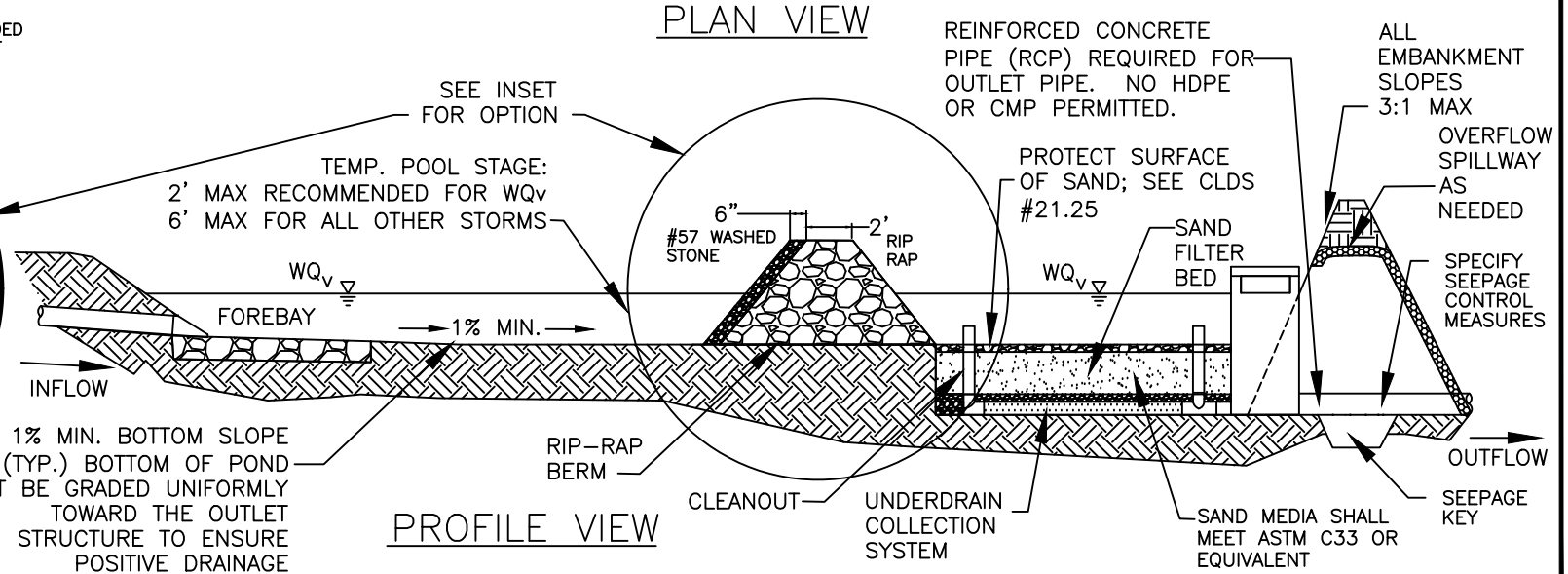
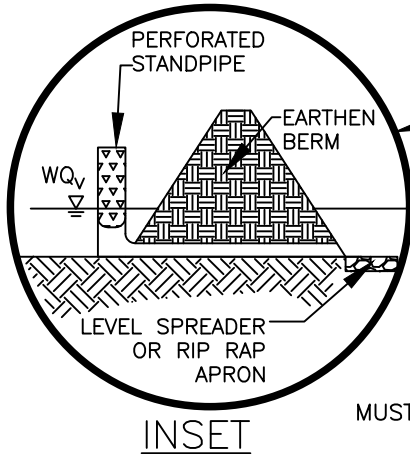
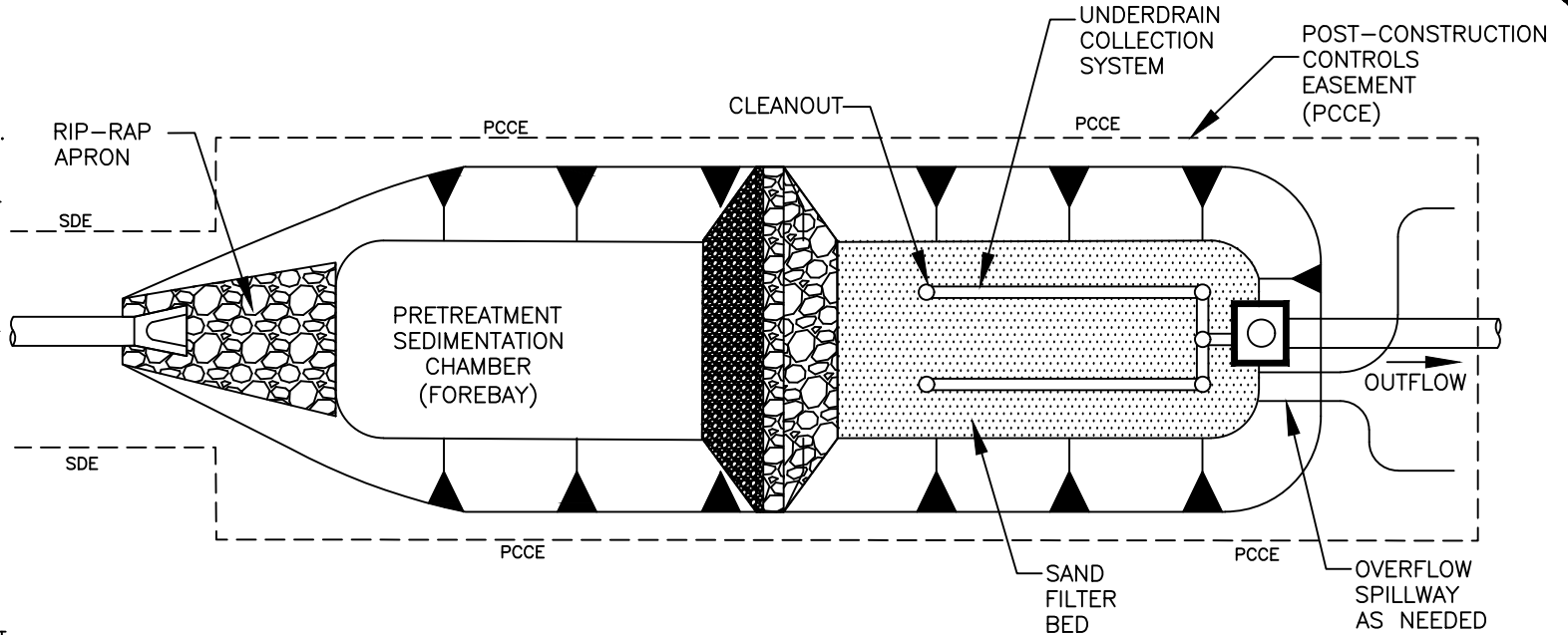

CITY OF CHARLOTTE
LAND DEVELOPMENT STANDARDS
 INCLUDES CHARLOTTE ETJ

SURFACE SAND FILTER

NOT TO SCALE

STD. NO.	REV.
21.24	25

THE TOP OF SURFACE SAND FILTER MEDIA MUST BE PROTECTED. USE WASHED BERMUDA SOD, OR A FILTER FABRIC WITH A LAYER OF WASHED #2 STONE ON TOP.

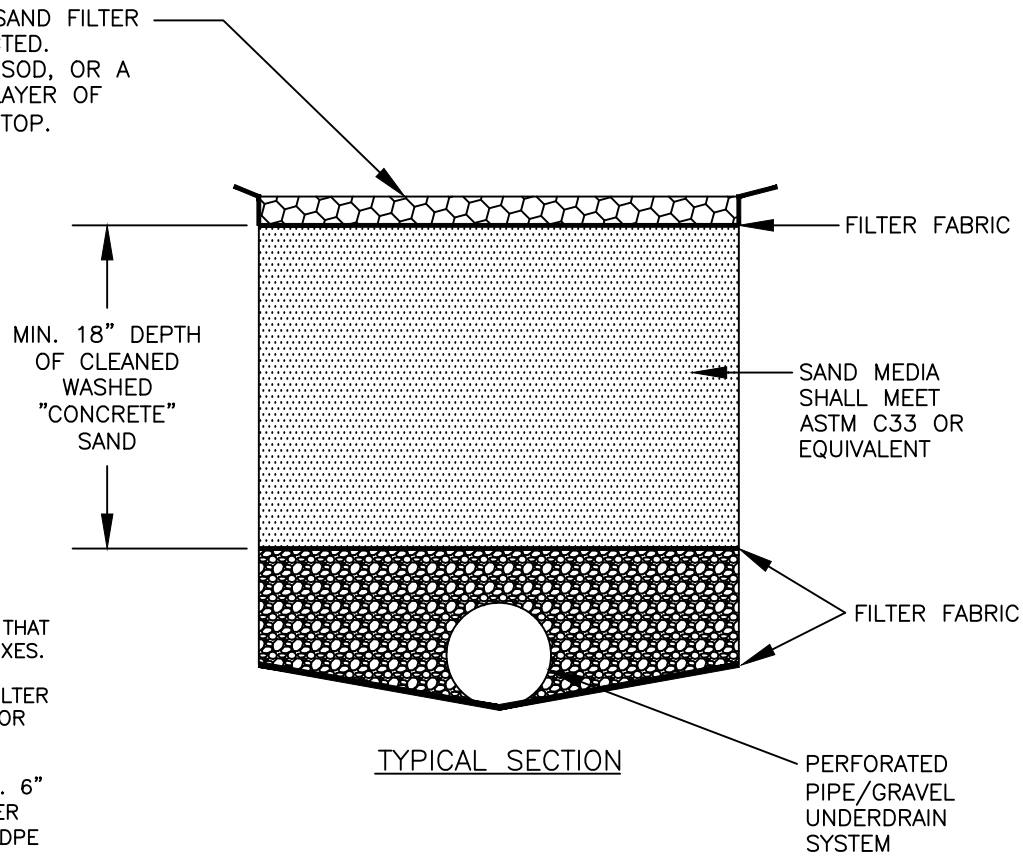

NOTES:

1. "CONCRETE" SAND REFERS TO SAND THAT IS COMMONLY USED IN CONCRETE MIXES.
2. ALL DRAINAGE AREAS TO A SAND FILTER FACILITY ARE TO BE STABILIZED PRIOR TO INSTALLATION OF SAND.
3. UNDERDRAIN PIPES SHOULD BE MIN. 6" PERFORATED SCHEDULE 40 PVC (PER AASHTO M278) OR DOUBLE WALL HDPE (PER AASHTO M252). PERFORATIONS SHOULD BE $\frac{3}{8}$ " SPACED 3" ON CENTER ALONG 4 LONGITUDINAL ROWS SPACED 90° APART.



CITY OF CHARLOTTE
 LAND DEVELOPMENT STANDARDS
 INCLUDES CHARLOTTE ETJ

SURFACE SAND FILTER SECTION

STD. NO.	REV.
21.25	24

CLDS #	NAME	REFERENCE FOR MAINT. NOTES
30.00	SPECIAL EROSION CONTROL REQUIRMENTS & NOTES	N/A
30.01	TEMPORARY SEDIMENT TRAP	6.60.5
30.02A	SKIMMER SEDIMENT BASIN	6.64.9
30.02B	SKIMMER	6.64.9
30.03A	SEDIMENT BASIN	6.61.8
30.03B	GENERAL NOTES--SEDIMENT BASINS	N/A
30.04	FLEXIBLE PIPE SLOPE DRAIN	6.32.3
30.05	TEMPORARY SILT DITCH	6.20.3 / 6.30.4
30.06A	TEMPORAY SILT FENCE	6.62.7
30.06B	HIGH HAZARD TEMPORARY SILT FENCE	SEE CLDS 30.06B DETAIL
30.06C	SILT FENCE OUTLET	SEE CLDS 30.06C DETAIL
30.06D	SUPER SILT FENCE	SEE CLDS 30.06D DETAIL
30.07	BLOCK AND GRAVEL STONE INLET PROTECTION	6.52.2
30.08	STONE INLET PROTECTION	6.55.3
30.09	HARDWARE CLOTH AND GRAVEL INLET PROTECTION	6.51.2
30.10A	TEMPORARY ROCK CHECK DAM	6.83.3
30.10B	TEMPORARY ROCK CHECK DAM W MATTING & PAM	6.83.3 / 6.86.5
30.10C	TEMPORARY WATTLE CHECK DAM W MATTING	N/A
30.10D	TEMPORARY WATTLE CHECK DAM W MATTING & PAM	N/A
30.11A	STABILIZED CONSTRUCTION ENTRANCE	6.06.2
30.11B	CONSTRUCTION ENTRANCE TIRE WASH	6.06.2
30.11C	SINGLE FAMILY LOT CONTROLS	6.06.2/CLDS 30.11C DETAIL
30.11D	URBAN BLOCK/LOT CONTROLS	SEE CLDS 30.11D DETAIL
30.12	GRAVEL AND RIP RAP FILTER BERM BASIN	6.63.5
30.13	EROSION CONTROL DEWATERING	N/A
30.14	TEMPORARY STREAM CROSSING	6.70.6
30.15	CATCH BASIN INLET PROTECTION	SEE CLDS 30.15 DETAIL
30.16	SLOPE STABILITY	6.02.3
30.17	TEMPORARY SEEDING SCHEDULE	6.10.3
30.18	TEMPORARY ASPHALT DIVERSION BERM	SEE CLDS 30.18 DETAIL
30.19	BAFFLE INSTALLATION	6.65.6
30.20	EMBANKMENT MATTING DETAIL	6.17.12
30.21	BRICK STORM STRUCTURE W TEMPORARY PIPE	N/A
30.22A	BYPASS PUMPING	N/A
30.22B	SUSPENDED BYPASS PIPE	N/A
30.22C	PIPED DIVERSION	N/A
30.23	TURBIDITY CURTAIN	SEE CLDS 30.23 DETAIL

THE NCDEQ MAINTENANCE REFERENCES INDICATED ARE FROM THE NORTH CAROLINA EROSION AND SEDIMENT CONTROL PLANNING AND DESIGN MANUAL (NCSCPD, LATEST EDITION) PREPARED BY NC DEPT. OF ENVIRONMENTAL QUALITY (NCDEQ); ALSO REFERENCE NCDOT ROADWAY STANDARD DRAWINGS, LATEST EDITION.



CITY OF CHARLOTTE
LAND DEVELOPMENT STANDARDS
 INCLUDES CHARLOTTE ETJ

EROSION CONTROL STANDARDS LIST &
 MAINTENANCE REFERENCES

STD. NO.	REV.
30.00	25

TEMPORARY SEDIMENT TRAP DESIGN CRITERIA	
DRAINAGE AREA (ACRES)	< 1 AC.
MIN. LENGTH TO WIDTH RATIO	2:1
MIN. VOLUME REQUIRED	3600 (CU. FT. PER AC. DISTURBED)
SURFACE AREA REQUIRED	435 (SQ. FT. PER CFS Q10)

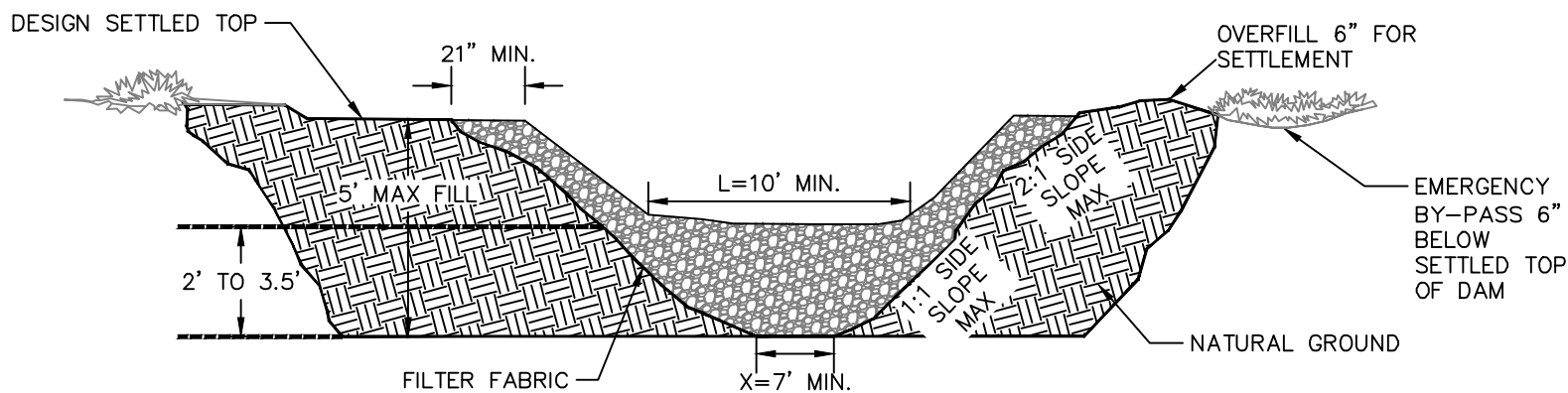
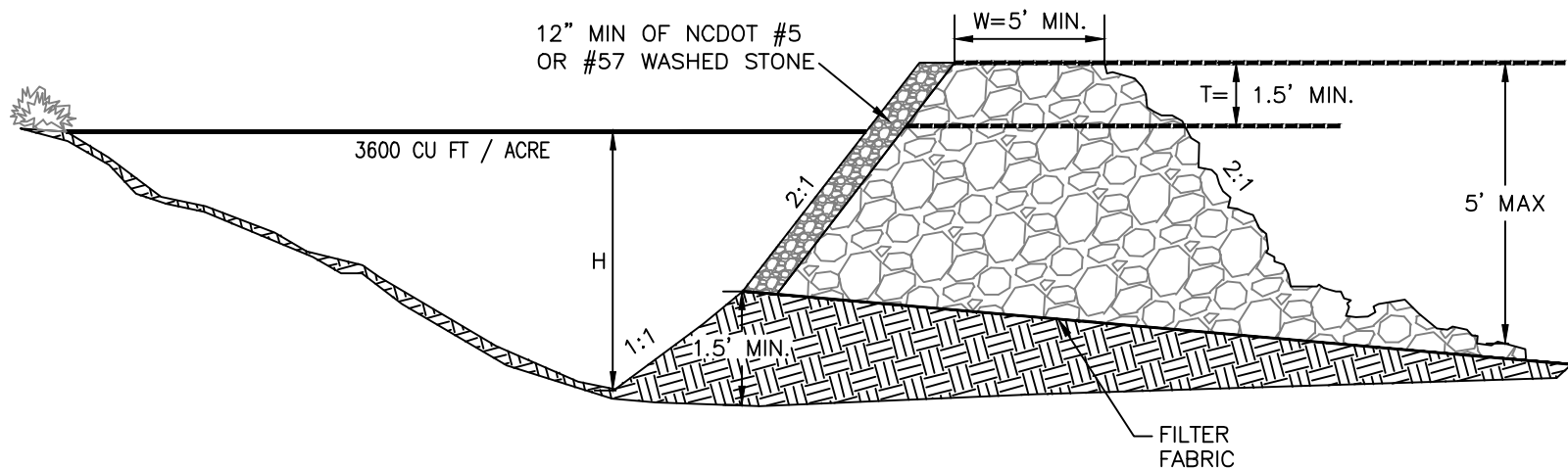

NOTES:

1. REFER TO NCESCPDM SECTION #6.60 FOR ADDITIONAL DESIGN SPECIFICATIONS REGARDING TEMPORARY SEDIMENT TRAPS.
2. REFER TO CLDS STANDARD #30.19 FOR BAFFLE SPACING

DATA BLOCK

NOT TO SCALE

TRAP NO.	DRAINAGE AREA (ACRES)	DENUDED AREA (ACRES)	Q ₁₀	TRAP VOLUME		TRAP SURFACE AREA		CLEANOUT DEPTH (FT.) H/2	H (FEET)	L (FEET)	T (FEET)	W (FEET)	X (FEET)
				REQUIRED (CUBIC FT.)	PROVIDED (CUBIC FT.)	REQUIRED (SQ FT.)	PROVIDED (SQ FT.)						



CITY OF CHARLOTTE
LAND DEVELOPMENT STANDARDS
 INCLUDES CHARLOTTE ETJ

TEMPORARY SEDIMENT TRAP

STD. NO.	REV.
30.01	15

SKIMMER SEDIMENT BASIN DESIGN CRITERIA	
DRAINAGE AREA (ACRES)	< 10 AC.
MIN. LENGTH TO WIDTH RATIO	2:1
MAX. LENGTH TO WIDTH RATIO	6:1
MIN. VOLUME REQUIRED	1800 (CU. FT. PER AC. DISTURBED)
SURFACE AREA REQUIRED	325 (SQ. FT. PER CFS Q10)

PLAN VIEW

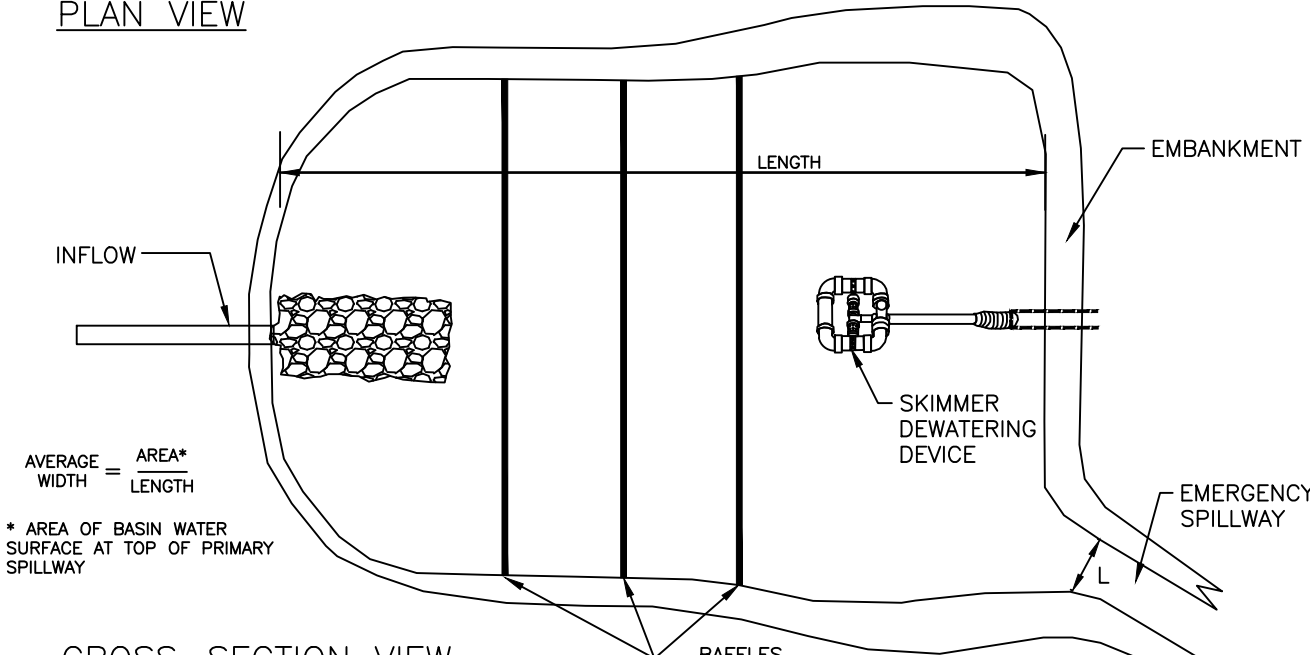

NOTES:

1. REFER TO NCESCPDM SECTION #6.64 FOR ADDITIONAL DESIGN SPECIFICATIONS REGARDING SKIMMER SEDIMENT BASINS.
2. REFER TO STD. #30.19 FOR BAFFLE SPACING AND INSTALLATION
3. TURBIDITY CURTAIN (CLDS #30.23) MAY BE USED IN LIEU OF POROUS BAFFLES (CLDS #30.19).
4. SKIMMER INVERT ELEVATION = BASIN BOTTOM + 1' MIN.
5. H = SPILLWAY ELEVATION - SKIMMER INVERT ELEVATION

CROSS-SECTION VIEW

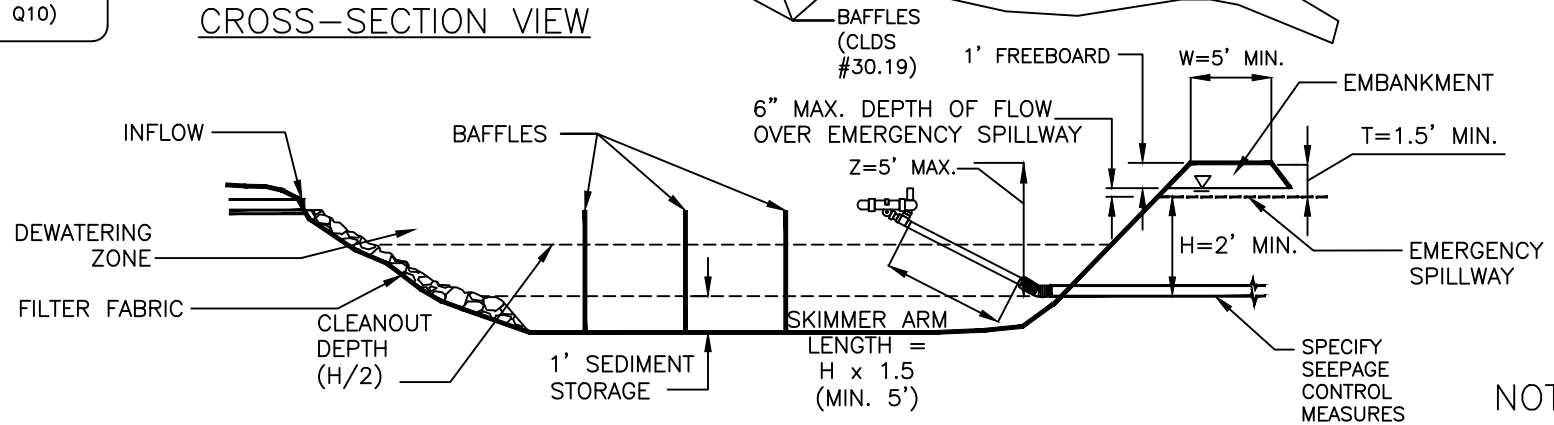

DATA BLOCK

BASIN	DRAINAGE AREA (ACRES)	DENUDED AREA (ACRES)	Q ₁₀	BASIN VOLUME		BASIN SURFACE AREA		CLEANOUT DEPTH (FT.) H/2	H (FEET)	Z (FEET)	L (FEET)	T (FEET)	W (FEET)	SKIMMER PIPE DIAMETER	SKIMMER ORIFICE DIAMETER
				REQUIRED (CUBIC FT.)	PROVIDED (CUBIC FT.)	REQUIRED (SQ FT.)	PROVIDED (SQ FT.)								

NOT TO SCALE



CITY OF CHARLOTTE
LAND DEVELOPMENT STANDARDS
INCLUDES CHARLOTTE ETJ

SKIMMER SEDIMENT BASIN

STD. NO.	REV.
30.02A	22

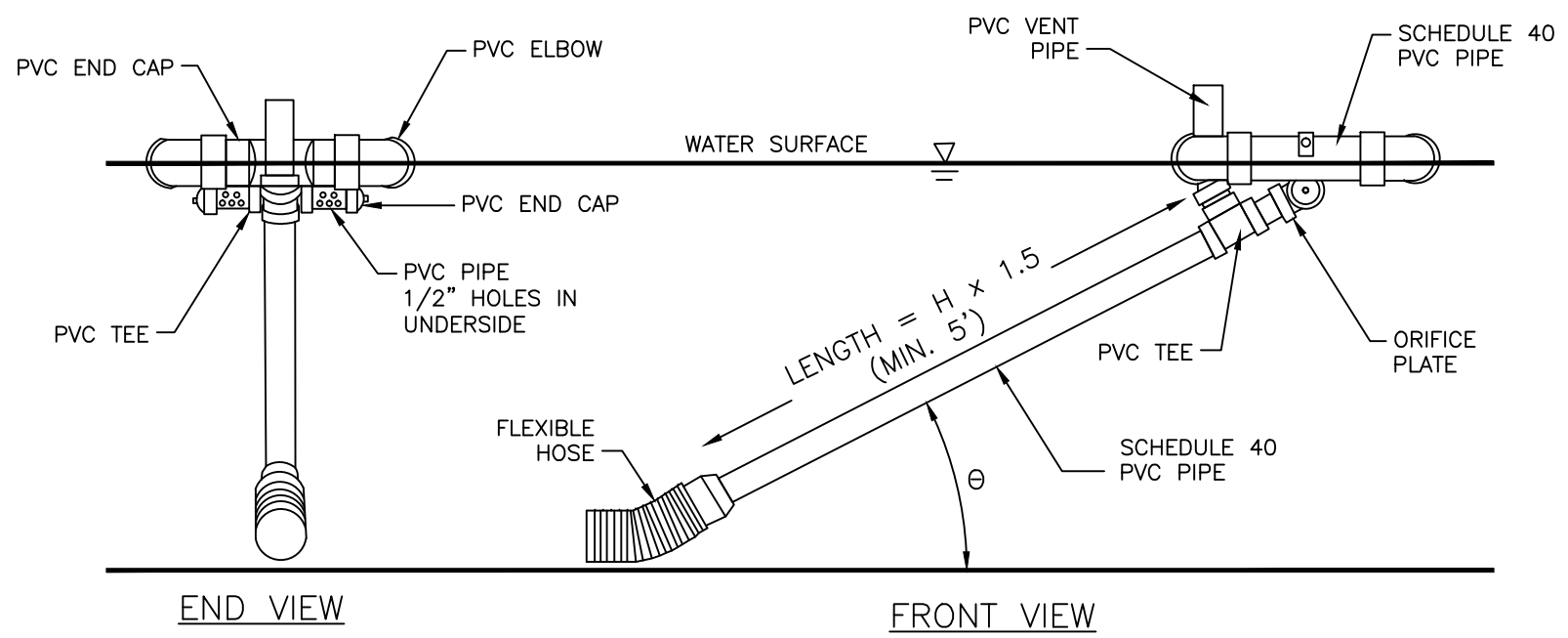
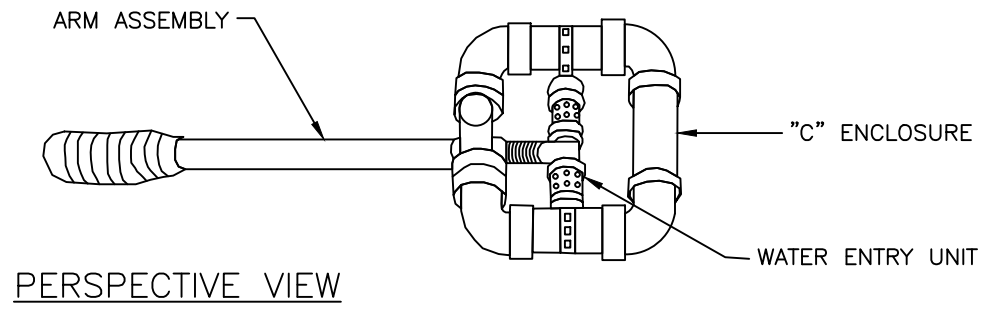

SCHEMATIC OF SKIMMER TAKEN FROM PENNSYLVANIA EROSION AND SEDIMENT POLLUTION CONTROL MANUAL, MARCH 2000.
 "H" REFERS TO THE HEIGHT FROM INVERT OF FLEXIBLE HOSE ON SKIMMER TO THE INVERT OF THE PRIMARY SPILLWAY.

NOT TO SCALE



CITY OF CHARLOTTE
 LAND DEVELOPMENT STANDARDS
 INCLUDES CHARLOTTE ETJ

SKIMMER

STD. NO.	REV.
30.02B	12

SEDIMENT BASIN DESIGN CRITERIA	
DRAINAGE AREA (ACRES)	>10 AC. <100 AC.
MIN. LENGTH TO WIDTH RATIO	2:1
MAX. LENGTH TO WIDTH RATIO	6:1
MIN. VOLUME REQUIRED	1800 (CU. FT. PER AC. DISTURBED)
SURFACE AREA REQUIRED	435 (SQ. FT. PER CFS Q10)

PLAN VIEW

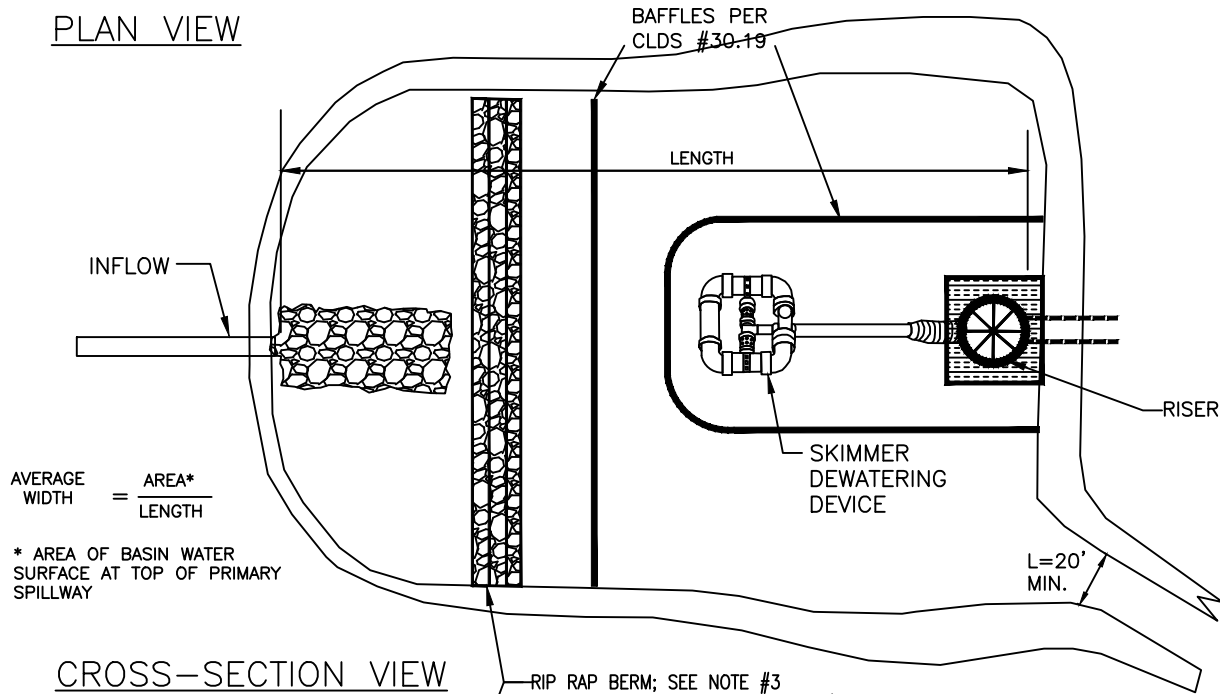

NOTES:

1. REFER TO NCESCPDM SECTION #6.61 FOR ADDITIONAL DESIGN SPECIFICATIONS REGARDING SEDIMENT BASINS.
2. REFER TO STD. #30.19 FOR BAFFLE SPACING AND INSTALLATION.
3. FIRST BAFFLE IS TO BE CONSTRUCTED OF RIP-RAP, WITH A MIN. HEIGHT OF 3' AND MIN. TOPWIDTH OF 2'.
4. TURBIDITY CURTAIN (CLDS #30.23) MAY BE USED IN LIEU OF POROUS BAFFLES (CLDS #30.19).
5. FLASHBOARD RISER NOT PERMITTED FOR USE IN THE CITY OF CHARLOTTE
6. SKIMMER INVERT ELEVATION = BASIN BOTTOM + 1' MIN.
7. H = SPILLWAY ELEVATION - SKIMMER INVERT ELEVATION

CROSS-SECTION VIEW

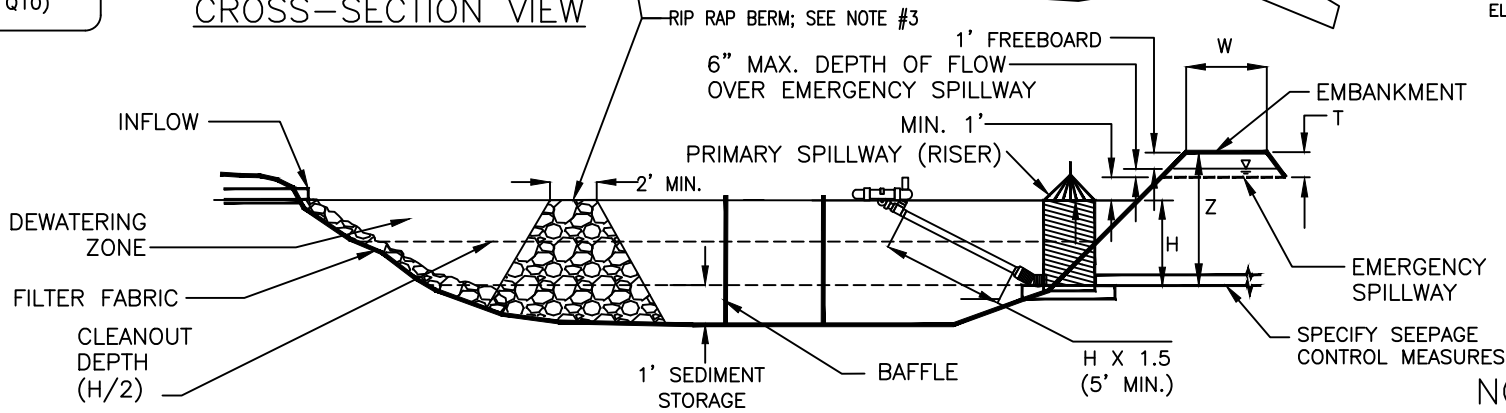

DATA BLOCK

BASIN	DRAINAGE AREA (ACRES)	DENUDED AREA (ACRES)	Q ₁₀	BASIN VOLUME		BASIN SURFACE AREA		CLEANOUT DEPTH (FT.) H/2	H (FEET)	Z (FEET)	L (FEET)	T (FEET)	W (FEET)	SKIMMER PIPE DIAMETER	SKIMMER ORIFICE DIAMETER
				REQUIRED (CUBIC FT.)	PROVIDED (CUBIC FT.)	REQUIRED (SQ FT.)	PROVIDED (SQ FT.)								

NOT TO SCALE



**CITY OF CHARLOTTE
LAND DEVELOPMENT STANDARDS**
INCLUDES CHARLOTTE ETJ

SEDIMENT BASIN

STD. NO.	REV.
30.03A	22

GENERAL NOTES:

1. AREA UNDER EMBANKMENT SHALL BE CLEARED, GRUBBED, AND STRIPPED OF ANY VEGETATION AND ROOT MATERIAL. THE BASIN AREA SHALL BE CLEARED.
2. THE FILL MATERIAL FOR THE EMBANKMENT SHALL BE FREE OF ROOTS OR OTHER WOODY VEGETATION AS WELL AS OVERSIZED STONES, ROCKS, ORGANIC MATERIAL, OR OTHER OBJECTIONABLE MATERIAL. THE EMBANKMENT SHALL BE COMPACTED BY TRAVERSING WITH EQUIPMENT WHILE BEING CONSTRUCTED. SPILLWAYS SHOULD NOT BE CONSTRUCTED THROUGH FILL SECTIONS. ALL SPILLWAYS SHOULD BE LINED AND/OR RIPRAPPED.
3. SEDIMENT SHALL BE REMOVED AND TRAP RESTORED TO ITS ORIGINAL DIMENSIONS WHEN THE SEDIMENT HAS ACCUMULATED TO A DEPTH SHOWN ON STANDARD. REMOVED SEDIMENT SHALL BE DEPOSITED IN A SUITABLE AREA IN SUCH A MANNER THAT IT WILL NOT ERODE.
4. THE BASIN SHALL BE INSPECTED AFTER EACH RAIN AND REPAIRS MADE AS NECESSARY.
5. ALL SEDIMENT BASIN SLOPES SHALL BE 3:1 OR FLATTER, UNLESS CERTIFIED BY REGISTERED GEOTECHNICAL ENGINEER.
6. SEDIMENT BASIN EMBANKMENTS SHOULD BE PROVIDED WITH EROSION CONTROL AND STABILIZATION.
7. STORAGE AREA MAY BE CONSTRUCTED IN ANY SHAPE PROVIDED THE MINIMUM STORAGE VOLUME REQUIREMENT IS MET. THE BASIN SHOULD ALSO BE ORIENTED SUCH THAT THE FILTER AND THE MAIN FLOW OF WATER AND SEDIMENT ARE ON OPPOSITE ENDS ON THE LONGER BASIN DIMENSIONS.
8. THE LENGTH OF THE STONE OUTLET (SPILLWAY) IS TO BE BASED ON A 10 YEAR STORM.
9. WHENEVER TOPOGRAPHY ALLOWS, THE BASIN LENGTH SHOULD BE TWICE (2X) THE BASIN WIDTH, TO ALLOW FOR SETTLING. BAFFLES SHALL BE INSTALLED IN ALL BASINS.
10. CLEANOUT STAKES SHALL BE PLACED IN ALL SEDIMENT BASINS AT THE LOW POINT IN THE BASIN. THE STAKES SHALL BE MARKED SHOWING THE HALF FULL, CLEANOUT POINT, OF THE BASIN.
11. FOR DESIGN OF SEDIMENT BASINS, REFER TO THE NORTH CAROLINA DEPARTMENT OF ENVIRONMENTAL QUALITY, EROSION AND SEDIMENT CONTROL PLANNING AND DESIGN MANUAL.
12. FOR SLOPES GREATER THAN 10' IN LENGTH AND PROTECTED BY SILT FENCE AT THE TOE OF THE SLOPE, SLOPE TERRACING WILL BE REQUIRED.
13. THE BERM ON SEDIMENT BASINS SHALL BE SEEDED ONCE FINAL GRADE HAS BEEN REACHED. THE SILT FENCE MAY BE REMOVED IF PERMISSION HAS BEEN GRANTED BY THE CITY LAND DEVELOPMENT INSPECTOR AFTER THE GRASS HAS GERMINATED AND STABLE GROUND HAS BEEN ESTABLISHED.



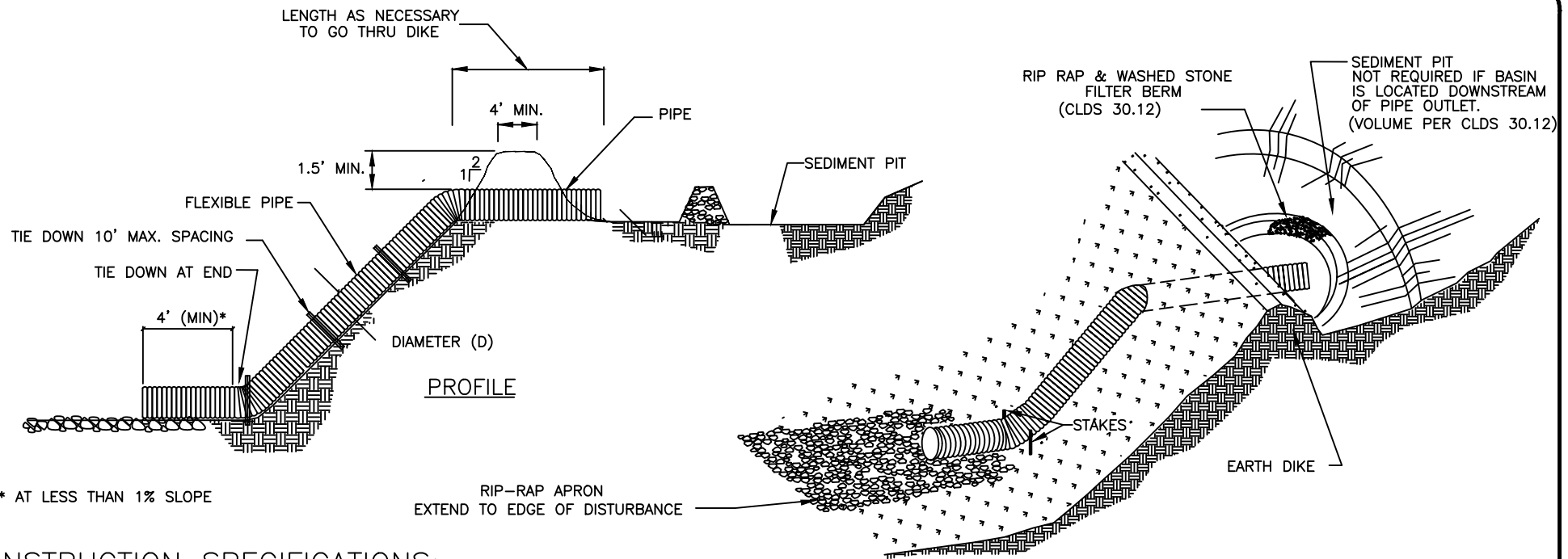

* AT LESS THAN 1% SLOPE

CONSTRUCTION SPECIFICATIONS:

1. THE TOP OF THE EARTH DIKE OVER THE INLET PIPE AND THOSE DIKES CARRYING WATER TO THE PIPE SHALL BE AT LEAST 1.5 FEET HIGHER AT ALL POINTS THAN THE TOP OF THE INLET PIPE.
2. THE PIPE SHALL BE FLEXIBLE WITH WATER TIGHT CONNECTING BANDS. FLEXIBLE PIPE SHOULD BE STAKED ON EITHER SIDE.
3. A RIP RAP APRON SHALL BE PROVIDED AT THE OUTLET, IF EMPTYING INTO A DISTURBED AREA.
4. THE SOIL AROUND AND UNDER THE INLET PIPE AND ENTRANCE SECTION SHALL BE HAND TAMPED IN 4" LIFTS TO THE TOP OF THE EARTH DIKE.
5. FOLLOW-UP INSPECTION AND ANY NEEDED MAINTENANCE SHALL BE PERFORMED AFTER EACH STORM BY THE FINANCIALLY RESPONSIBLE PARTY OR HIS AGENT.
6. OUTLET PIPE SHOULD BE TAKEN OVER OR THROUGH ANY SILT FENCE, TAKING CARE NOT TO VOID THE EFFECTIVENESS OF THE SILT FENCE.

UNLESS THEY ARE INDIVIDUALLY DESIGNED,
SIZE THE DRAINS AS FOLLOWS:

MAXIMUM DRAINAGE AREA PER PIPE (ACRES)	PIPE DIAMETER (INCHES)
0.5	12
0.75	15
1.00	18
>1.00	AS DESIGNED

NOT TO SCALE



CITY OF CHARLOTTE
LAND DEVELOPMENT STANDARDS
INCLUDES CHARLOTTE ETJ

FLEXIBLE PIPE SLOPE DRAIN

STD. NO.	REV.
30.04	20

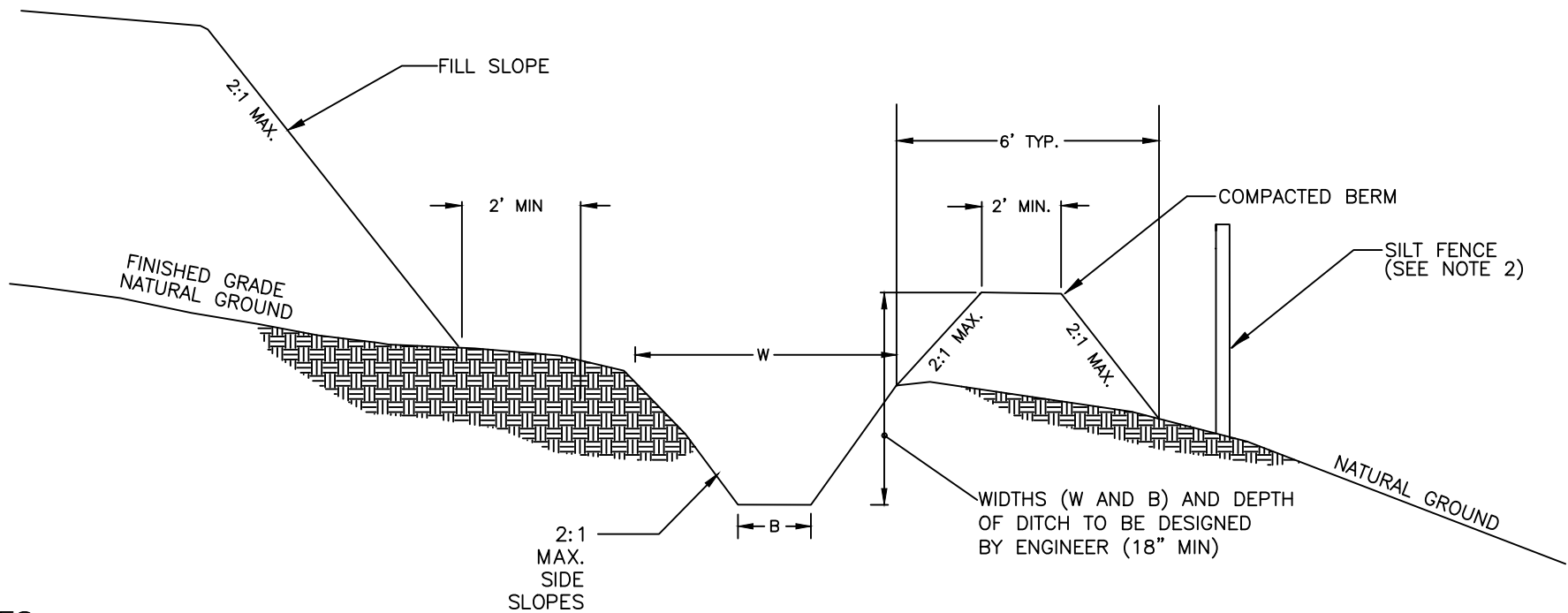

NOTES:

1. DITCH SHOULD HAVE LONGITUDINAL SLOPE OF 1%.
2. SILT FENCE MAY BE REQUIRED BEHIND BERM
3. DITCHES SHOULD BE STABILIZED IN ACCORDANCE WITH THE TEMPORARY STABILIZATION REQUIREMENTS OF THE NCG010000 PERMIT.
4. WHERE DESIGN VELOCITIES EXCEED 2 FT/SEC, A CHANNEL LINER IS NECESSARY TO PREVENT DITCH EROSION.

DITCH NO.	AREA(AC.)	DEPTH*	W(FT)	B(FT)	VELOCITY ₁₀	ROLLED EROSION CONTROL PRODUCT / LINING TYPE

* = DEPTH INCLUDES 6" FREEBOARD
W = WIDTH AT TOP OF DITCH
B = WIDTH AT BOTTOM OF DITCH

NOT TO SCALE



CITY OF CHARLOTTE
LAND DEVELOPMENT STANDARDS
INCLUDES CHARLOTTE ETJ

TEMPORARY SILT DITCH

STD. NO.	REV.
30.05	22

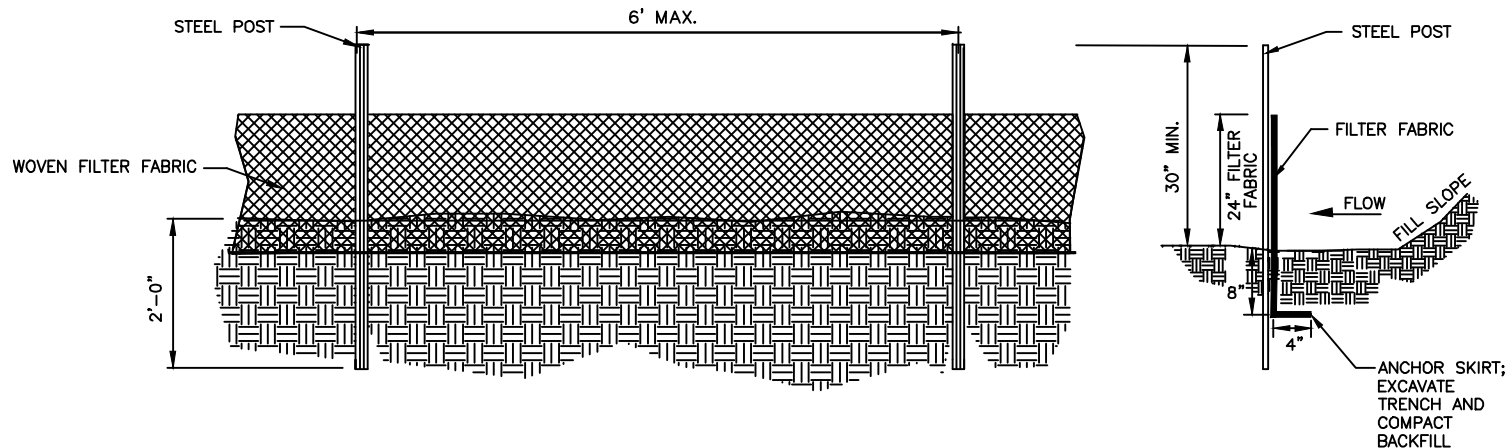

GENERAL NOTES:

1. WOVEN FILTER FABRIC BE USED WHERE SILT FENCE IS TO REMAIN FOR A PERIOD OF MORE THAN 30 DAYS.
2. STEEL POSTS SHALL BE 5'-0" IN HEIGHT AND BE OF THE SELF-FASTENER ANGLE STEEL TYPE.
3. TURN SILT FENCE UP SLOPE AT ENDS.
4. ORANGE SAFETY FENCE IS REQUIRED AT BACK OF SILT FENCE WHEN GRADING IS ADJACENT TO SWIM BUFFERS, STREAMS OR WETLANDS (REFER TO SWIM BUFFER GUIDELINES). THE COLOR ORANGE IS RESERVED FOR VISUAL IDENTIFICATION OF ENVIRONMENTALLY SENSITIVE AREAS.
5. DRAINAGE AREA CAN NOT BE GREATER THAN 1/4 ACRE PER 100 FT OF FENCE.
6. SLOPE LENGTHS CAN NOT EXCEED CRITERIA SHOWN IN TABLE 6.62A NORTH CAROLINA EROSION AND SEDIMENT CONTROL PLANNING AND DESIGN MANUAL.
7. DO NOT INSTALL SEDIMENT FENCE ACROSS STREAMS, DITCHES, WATERWAYS OR OTHER AREAS OF CONCENTRATED FLOW.

MAINTENANCE NOTES:

1. FILTER BARRIERS SHALL BE INSPECTED BY THE FINANCIALLY RESPONSIBLE PARTY OR HIS AGENT IMMEDIATELY AFTER EACH RAINFALL AND AT LEAST DAILY DURING PROLONGED RAINFALL. ANY REPAIRS NEEDED SHALL BE MADE IMMEDIATELY.
2. SHOULD THE FABRIC DECOMPOSE OR BECOME INEFFECTIVE PRIOR TO THE END OF THE EXPECTED USABLE LIFE AND THE BARRIER STILL IS NECESSARY, THE FABRIC SHALL BE REPLACED PROMPTLY.
3. SEDIMENT DEPOSITS SHOULD BE REMOVED WHEN DEPOSITS REACH APPROX. HALF THE HEIGHT OF THE BARRIER. ANY SEDIMENT DEPOSITS REMAINING IN PLACE AFTER THE SILT FENCE IS REMOVED SHALL BE DRESSED TO CONFORM TO THE EXISTING GRADE, PREPARED AND SEEDED.

NOT TO SCALE



CITY OF CHARLOTTE
 LAND DEVELOPMENT STANDARDS
 INCLUDES CHARLOTTE ETJ

TEMPORARY SILT FENCE

STD. NO.	REV.
30.06A	15

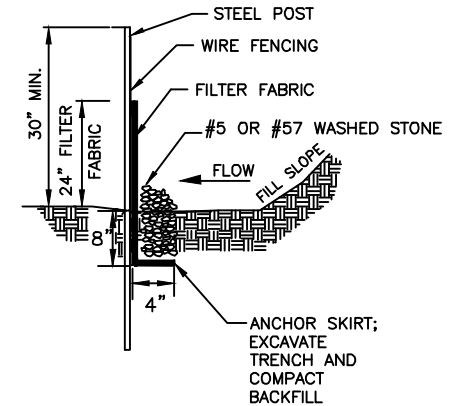
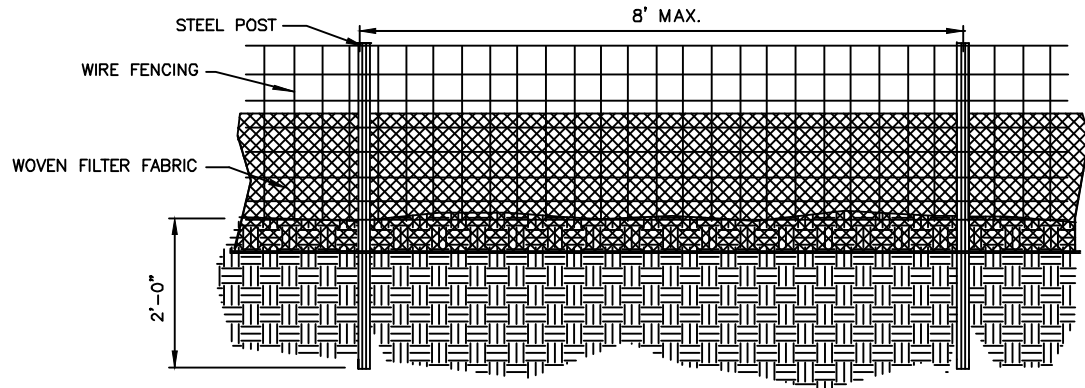

GENERAL NOTES:

1. WIRE FENCING SHALL BE A MINIMUM OF 32" IN WIDTH AND SHALL HAVE A MINIMUM OF 6 LINE WIRES WITH 12" STAY SPACING.
2. WOVEN FILTER FABRIC BE USED WHERE SILT FENCE IS TO REMAIN FOR A PERIOD OF MORE THAN 30 DAYS.
3. STEEL POSTS SHALL BE 5'-0" IN HEIGHT AND BE OF THE SELF-FASTENER ANGLE STEEL TYPE.
4. WIRE FENCING SHALL BE AT LEAST #10 GAGE WITH A MINIMUM OF 6 LINE WIRES WITH 6" STAY SPACING.
5. TURN SILT FENCE UP SLOPE AT ENDS.
6. WIRE AND WASHED STONE IS REQUIRED TO BE SHOWN ON PLANS AT THE TOE OF SLOPES GREATER THAN 10 FEET VERTICAL (2:1 SLOPE)
7. ORANGE SAFETY FENCE IS REQUIRED AT BACK OF SILT FENCE WHEN GRADING IS ADJACENT TO SWIM BUFFERS, STREAMS OR WETLANDS (REFER TO SWIM BUFFER GUIDELINES). THE COLOR ORANGE IS RESERVED FOR VISUAL IDENTIFICATION OF ENVIRONMENTALLY SENSITIVE AREAS.
8. DRAINAGE AREA CAN NOT BE GREATER THAN 1/4 ACRE PER 100 FT OF FENCE.
9. SLOPE LENGTHS CAN NOT EXCEED CRITERIA SHOWN IN TABLE 6.62A NORTH CAROLINA EROSION AND SEDIMENT CONTROL PLANNING AND DESIGN MANUAL.
10. DO NOT INSTALL SEDIMENT FENCE ACROSS STREAMS, DITCHES, WATERWAYS OR OTHER AREAS OF CONCENTRATED FLOW.

MAINTENANCE NOTES:

1. FILTER BARRIERS SHALL BE INSPECTED BY THE FINANCIALLY RESPONSIBLE PARTY OR HIS AGENT IMMEDIATELY AFTER EACH RAINFALL AND AT LEAST DAILY DURING PROLONGED RAINFALL. ANY REPAIRS NEEDED SHALL BE MADE IMMEDIATELY.
2. SHOULD THE FABRIC DECOMPOSE OR BECOME INEFFECTIVE PRIOR TO THE END OF THE EXPECTED USABLE LIFE AND THE BARRIER STILL IS NECESSARY, THE FABRIC SHALL BE REPLACED PROMPTLY.
3. SEDIMENT DEPOSITS SHOULD BE REMOVED WHEN DEPOSITS REACH HALF THE HEIGHT OF THE BARRIER. ANY SEDIMENT DEPOSITS REMAINING IN PLACE AFTER THE SILT FENCE IS REMOVED SHALL BE DRESSED TO CONFORM TO THE EXISTING GRADE, PREPARED AND SEEDED.

NOT TO SCALE



**CITY OF CHARLOTTE
LAND DEVELOPMENT STANDARDS**
INCLUDES CHARLOTTE ETJ

**HIGH HAZARD
TEMPORARY SILT FENCE**

STD. NO.	REV.
30.06B	15

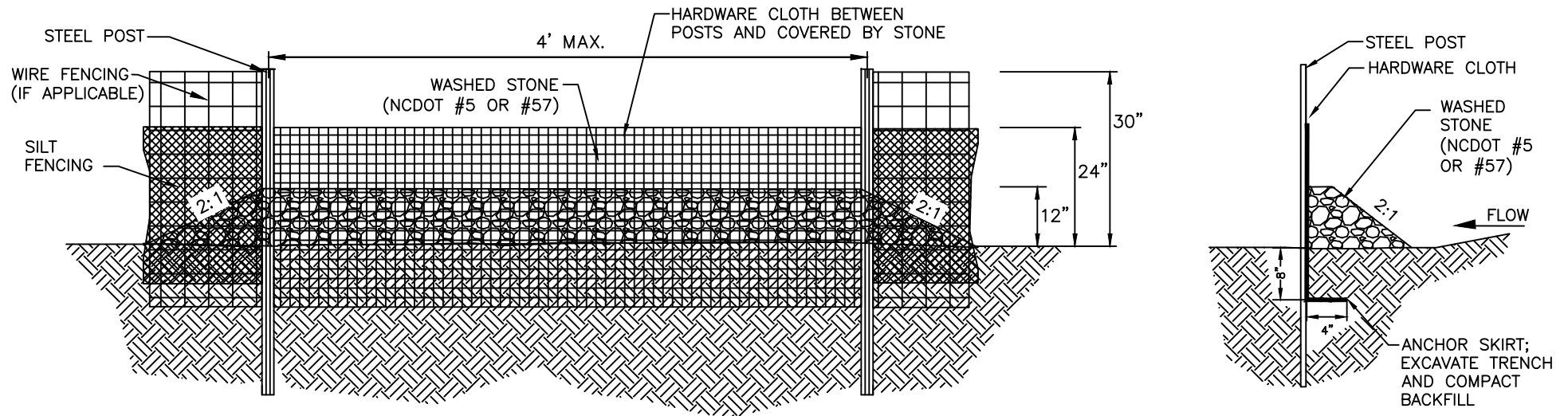

GENERAL NOTES:

1. SEDIMENT FILTER OUTLET HARDWARE CLOTH SHALL BE 24" HIGH AND STONE SHALL BE A MINIMUM OF 12" HIGH.
2. HARDWARE CLOTH SHALL BE ANCHORED TO THE STEEL POSTS SECURELY USING APPROPRIATE ANCHORS. HARDWARE CLOTH SHALL BE KEYED IN A MINIMUM OF 12 INCHES IN LENGTH AND BACKFILLED PROPERLY AS SHOWN IN ABOVE DETAIL. HARDWARE CLOTH TO BE SAME AS STD. #30.09 (19 GAUGE, 1/4" SPACING).
3. POSTS SHALL BE NO MORE THAN 4 FEET APART.
4. SITE OUTLETS AT LOW AREAS IN CONJUNCTION WITH AND ALONG LONG RUNS OF SILT FENCE AT INTERVALS NO CLOSER THAN 100 FEET. DRAINAGE AREA TO OUTLETS SHALL NOT EXCEED 1/4 ACRE.
5. EQUIVALENT ALTERNATIVES MAY BE USED WITH PRIOR CITY APPROVAL.

MAINTENANCE NOTES:

1. FILTER OUTLETS SHALL BE INSPECTED BY THE FINANCIALLY RESPONSIBLE PARTY OR HIS AGENT IMMEDIATELY AFTER EACH RAINFALL AND AT LEAST DAILY DURING PROLONGED RAINFALL. ANY REPAIRS NEEDED SHALL BE MADE IMMEDIATELY.
2. THE STONE SHALL BE REPLACED PROMPTLY AFTER ANY EVENT THAT HAS CLOGGED OR REMOVED IT.
3. SEDIMENT DEPOSITS SHOULD BE REMOVED WHEN DEPOSITS REACH HALF THE HEIGHT OF THE BARRIER. ANY SEDIMENT DEPOSITS REMAINING IN PLACE AFTER THE SILT FENCE OUTLET IS REMOVED SHALL BE DRESSED TO CONFORM TO THE EXISTING GRADE, PREPARED AND SEEDED.

NOT TO SCALE



CITY OF CHARLOTTE
 LAND DEVELOPMENT STANDARDS
 INCLUDES CHARLOTTE ETJ

SILT FENCE
 OUTLET

STD. NO.	REV.
30.06C	20

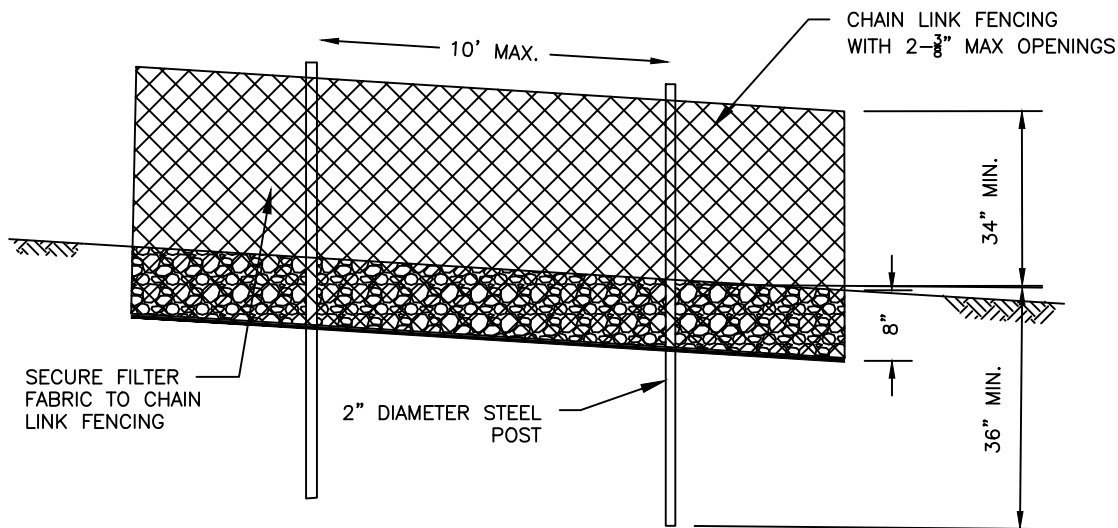

ELEVATION

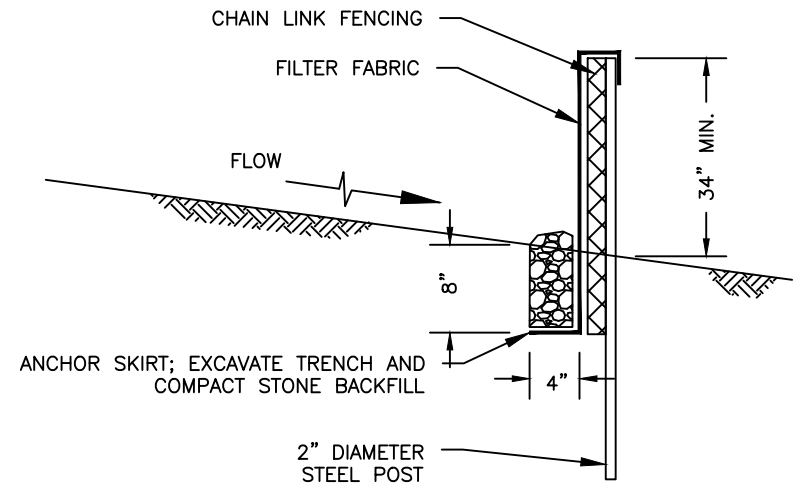

CROSS SECTION

GENERAL NOTES:

1. SUPER SILT FENCE MAY BE USED IN CRITICAL AREAS IN LIEU OF DOUBLE ROW HIGH HAZARD SILT FENCE.
2. INSTALL MINIMUM 2 INCH DIAMETER GALVANIZED STEEL POSTS, SIX FOOT LENGTH, SPACED NO FURTHER THAN 10 FEET APART. DRIVE THE POSTS A MINIMUM OF 36" INTO THE GROUND.
3. FASTEN 9 GAUGE OR HEAVIER GALVANIZED CHAIN LINK FENCE (2 3/8 INCH MAXIMUM OPENING) 42 INCHES IN HEIGHT SECURELY TO THE FENCE POSTS WITH WIRE TIES OR HOG RINGS.
4. WHERE ENDS OF THE GEOTEXTILE COME TOGETHER, THE ENDS SHALL BE OVERLAPPED BY 6 INCHES, FOLDED, AND STAPLED TO PREVENT SEDIMENT BYPASS.
5. EXTEND BOTH ENDS OF THE SUPER SILT FENCE A MINIMUM OF FIVE HORIZONTAL FEET UPSLOPE AT 45 DEGREES TO THE MAIN FENCE ALIGNMENT TO PREVENT RUNOFF FROM GOING AROUND THE ENDS OF THE SUPER SILT FENCE.
6. WASHED STONE (#5 OR #57) SHALL BE USED IN THE SILT FENCE TRENCH AND COMPACTED.
7. ORANGE SAFETY FENCE IS REQUIRED WHEN GRADING IS ADJACENT TO SWIM BUFFERS, STREAMS OR WETLANDS (REFER TO SWIM BUFFER GUIDELINES). THE COLOR ORANGE IS RESERVED FOR VISUAL IDENTIFICATION OF ENVIRONMENTALLY SENSITIVE AREAS.

8. DRAINAGE AREA CANNOT BE GREATER THAN 1/4 ACRE PER 100 FT OF FENCE.
9. SLOPE LENGTHS CANNOT EXCEED CRITERIA SHOWN IN TABLE 6.62A NORTH CAROLINA EROSION AND SEDIMENT CONTROL PLANNING AND DESIGN MANUAL.
10. DO NOT INSTALL SUPER SILT FENCE ACROSS STREAMS, DITCHES, WATERWAYS OR OTHER AREAS OF CONCENTRATED FLOW.

MAINTENANCE NOTES:

1. FILTER BARRIERS SHALL BE INSPECTED BY THE FINANCIALLY RESPONSIBLE PARTY OR HIS AGENT IMMEDIATELY AFTER EACH RAINFALL AND AT LEAST DAILY DURING PROLONGED RAINFALL. ANY REPAIRS NEEDED SHALL BE MADE IMMEDIATELY.
2. SHOULD THE FABRIC DECOMPOSE OR BECOME INEFFECTIVE PRIOR TO THE END OF THE EXPECTED USABLE LIFE AND THE BARRIER STILL IS NECESSARY, THE FABRIC SHALL BE REPLACED PROMPTLY.
3. SEDIMENT DEPOSITS SHOULD BE REMOVED WHEN DEPOSITS REACH HALF THE HEIGHT OF THE BARRIER. ANY SEDIMENT DEPOSITS REMAINING IN PLACE AFTER THE SILT FENCE IS REMOVED SHALL BE DRESSED TO CONFORM TO THE EXISTING GRADE, PREPARED AND SEEDED.

NOT TO SCALE



CITY OF CHARLOTTE
LAND DEVELOPMENT STANDARDS
INCLUDES CHARLOTTE ETJ

SUPER SILT FENCE

STD. NO.	REV.
30.06D	18

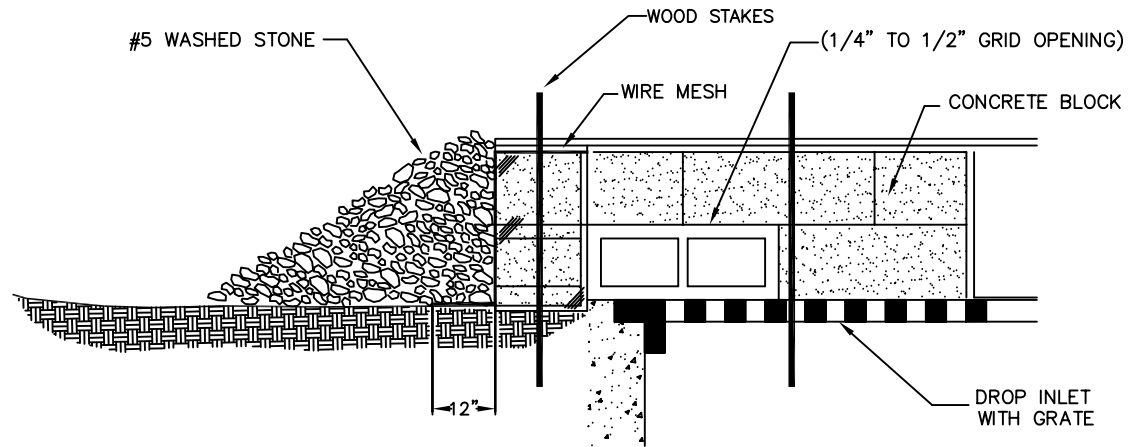
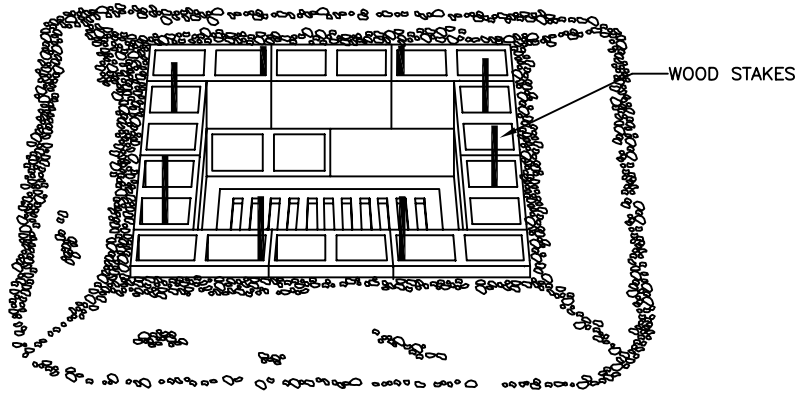

SPECIFIC APPLICATION:

THIS METHOD OF INLET PROTECTION IS APPLICABLE WHERE HEAVY FLOWS ARE EXPECTED AND WHERE OVERFLOW CAPACITY IS NECESSARY TO PREVENT EXCESSIVE PONDING AROUND THE STRUCTURE.

NOT TO SCALE



CITY OF CHARLOTTE
 LAND DEVELOPMENT STANDARDS
 INCLUDES CHARLOTTE ETJ

BLOCK AND GRAVEL
 STONE INLET PROTECTION

STD. NO.	REV.
30.07	

GENERAL NOTES:

1. SEDIMENT SHALL BE REMOVED AND TRAP RESTORED TO ITS ORIGINAL DIMENSIONS WHEN THE SEDIMENT HAS ACCUMULATED TO 1/2 THE DESIGN DEPTH OF THE TRAP.
2. REMOVED SEDIMENT SHALL BE DEPOSITED IN A SUITABLE AREA AND IN SUCH A MANNER THAT IT WILL NOT ERODE.
3. THE STRUCTURE SHALL BE INSPECTED BY THE FINANCIALLY RESPONSIBLE PARTY OR HIS AGENT AFTER EACH STORM EVENT AND REPAIRS MADE AS NECESSARY.
4. CONSTRUCTION OPERATIONS SHALL BE CARRIED OUT IN SUCH A MANNER THAT EROSION AND WATER POLLUTION ARE MINIMIZED.
5. THE SEDIMENT TRAP SHALL BE REMOVED AND THE AREA STABILIZED WHEN THE DRAINAGE BASIN HAS BEEN PROPERLY STABILIZED.
6. ON LARGER DRAINAGE AREAS RIP RAP MAY BE REQUIRED UNDER THE WASHED STONE.

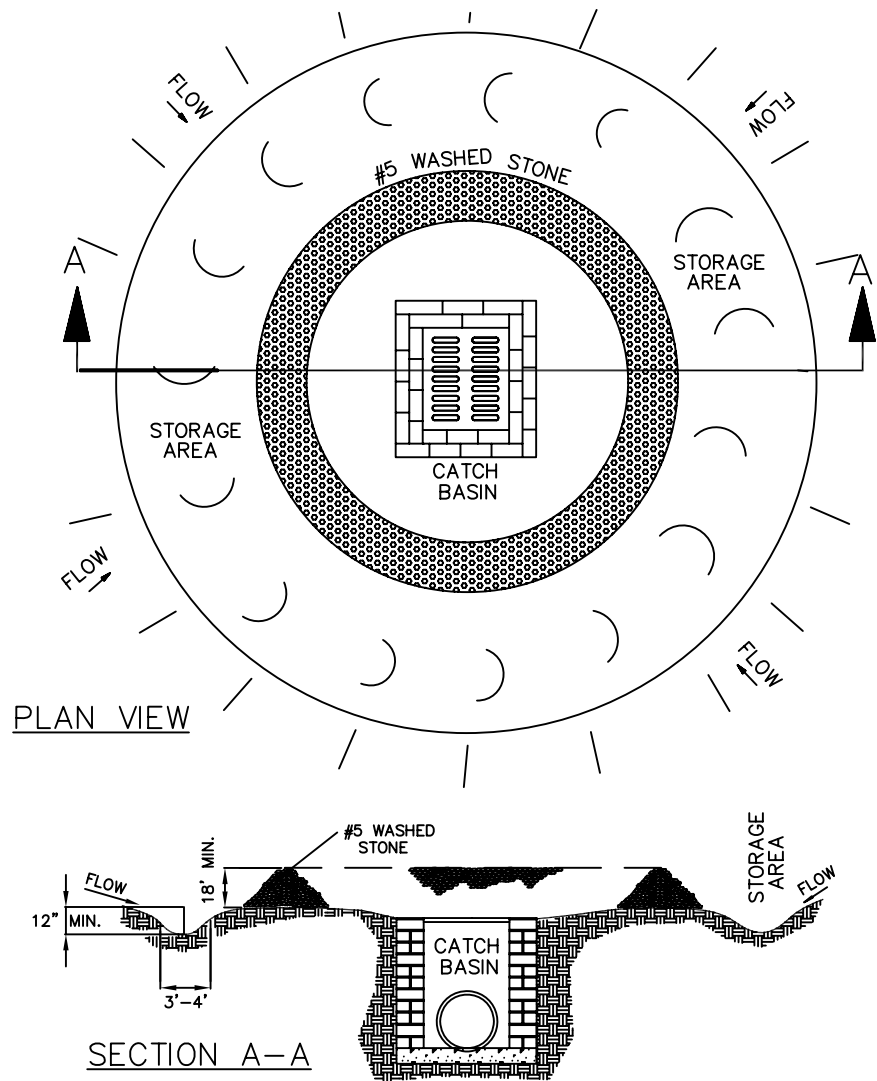

NOT TO SCALE



CITY OF CHARLOTTE
 LAND DEVELOPMENT STANDARDS
 INCLUDES CHARLOTTE ETJ

STONE INLET PROTECTION

STD. NO.	REV.
30.08	

GENERAL NOTES:

1. UNIFORMLY GRADE A SHALLOW DEPRESSION APPROACHING THE INLET.
2. DRIVE 5-FOOT STEEL POSTS 2 FEET INTO THE GROUND SURROUNDING THE INLET. SPACE POSTS EVENLY AROUND THE PERIMETER OF THE INLET, A MAXIMUM OF 4 FEET APART.
3. SURROUND THE POSTS WITH WIRE MESH HARDWARE CLOTH. SECURE THE WIRE MESH TO THE STEEL POSTS AT THE TOP, MIDDLE, AND BOTTOM. PLACING A 2-FOOT FLAP OF THE WIRE MESH UNDER THE GRAVEL FOR ANCHORING IS RECOMMENDED.
4. PLACE CLEAN GRAVEL (NC DOT #5 OR #57 STONE) ON A 2:1 SLOPE WITH A HEIGHT OF 16 INCHES AROUND THE WIRE, AND SMOOTH TO AN EVEN GRADE.
5. ONCE THE CONTRIBUTING DRAINAGE AREA HAS BEEN STABILIZED, REMOVE ACCUMULATED SEDIMENT, AND ESTABLISH FINAL GRADING ELEVATIONS.
6. COMPACT THE AREA PROPERLY AND STABILIZED IT WITH GROUND COVER.

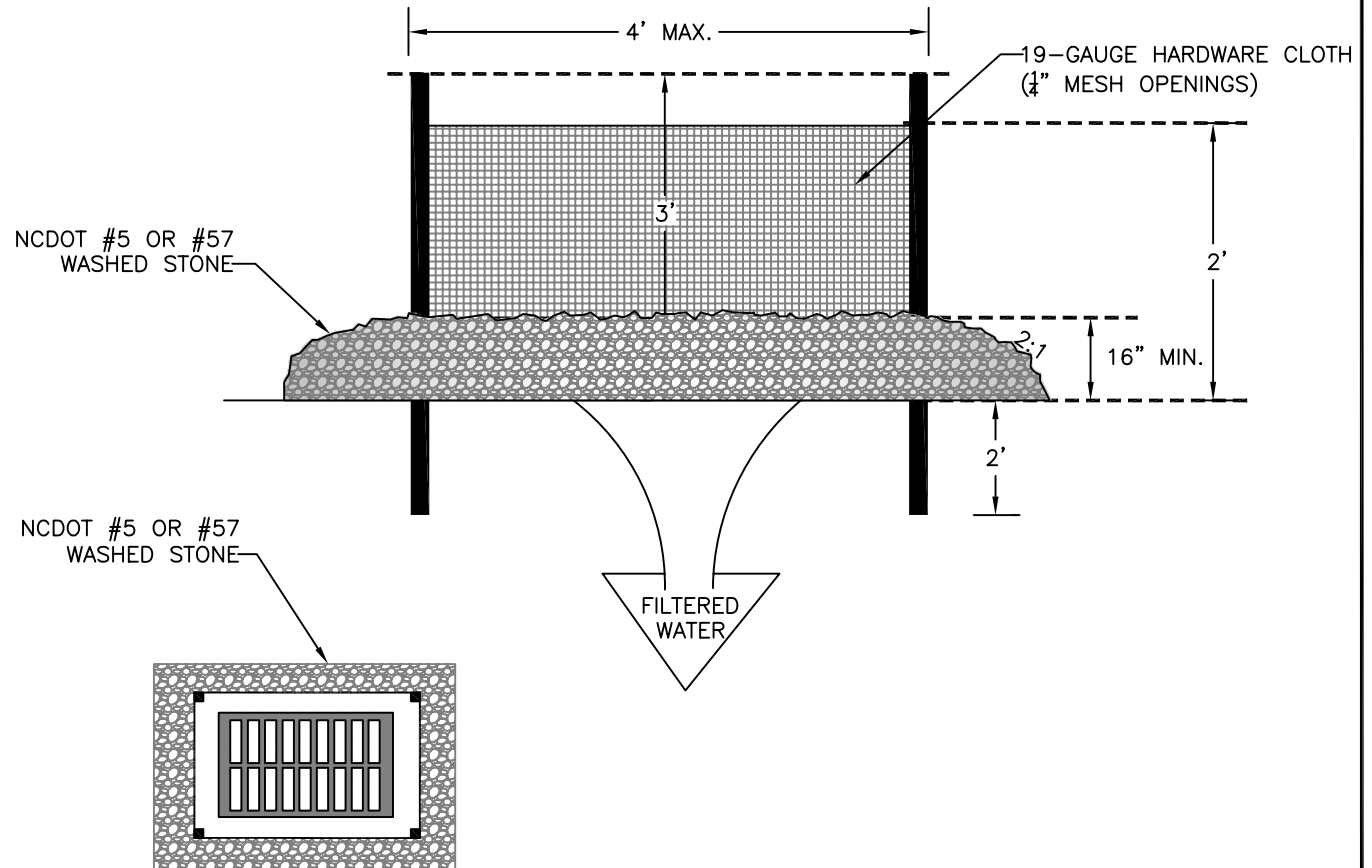

NOT TO SCALE



CITY OF CHARLOTTE
 LAND DEVELOPMENT STANDARDS
 INCLUDES CHARLOTTE ETJ

HARDWARE CLOTH AND GRAVEL
 INLET PROTECTION

STD. NO.	REV.
30.09	1

GENERAL NOTES:

1. RIPRAP SIZE TO BE DESIGNED BY ENGINEER.
2. CHECK DAMS MAY BE USED IN SLOPING DITCHES OR CHANNELS TO SLOW VELOCITY OR TO CREATE SEDIMENT TRAPS.
3. ENSURE THAT MAXIMUM SPACING BETWEEN DAMS PLACES THE TOE OF THE UPSTREAM DAM AT THE SAME ELEVATION AS THE DOWNSTREAM DAM (SEE DIAGRAM BELOW).

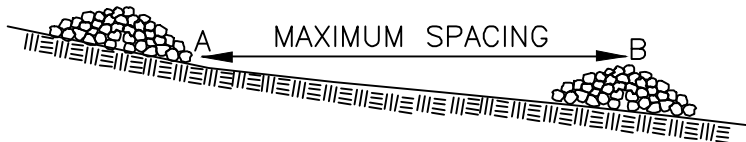

A AND B ARE AT EQUAL ELEVATIONS

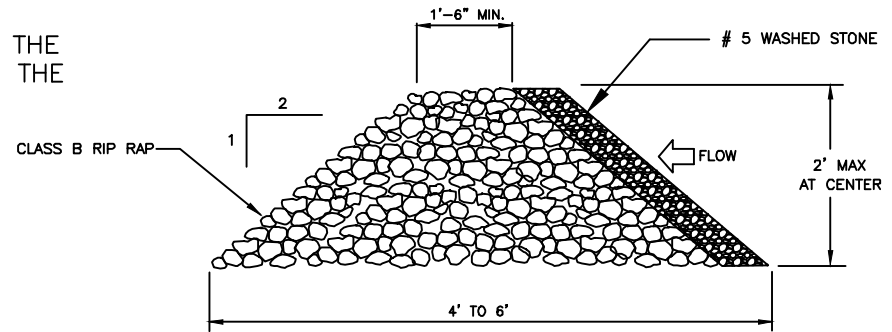

CROSS SECTION

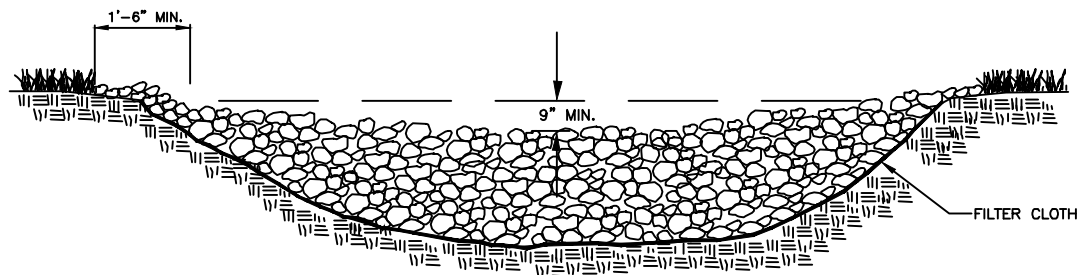

PLAN

NOT TO SCALE



CITY OF CHARLOTTE
LAND DEVELOPMENT STANDARDS
INCLUDES CHARLOTTE ETJ

TEMPORARY ROCK CHECK DAM

STD. NO.	REV.
30.10A	15

GENERAL NOTES:

1. CHECK DAMS MAY BE USED IN SLOPING DITCHES OR CHANNELS TO SLOW VELOCITY OR TO CREATE SEDIMENT TRAPS.
2. ENSURE THAT MAXIMUM SPACING BETWEEN DAMS PLACES THE TOE OF THE UPSTREAM DAM AT THE SAME ELEVATION AS THE DOWNSTREAM DAM (SEE DIAGRAM BELOW).
3. COIR MATTING SHALL BE SUBSTITUTED FOR EXCELSIOR MATTING IN HIGH FLOW AREAS.
4. INITIALLY APPLY 3.50 OUNCES OF POLYACRYLAMIDE (PAM) TO THE FACE AND TOP OF THE CHECK DAM AND AFTER EVERY RAINFALL EVENT THAT EQUALS OR EXCEEDS 0.50 INCHES.
5. ONLY PAMs THAT PASS THE CHRONIC TOXICITY TESTING REQUIREMENTS, ESTABLISHED BY NCDWQ, MAY BE USED.
6. A SEDIMENT BASIN OR SIMILAR STRUCTURE BETWEEN THE APPLICATION POINT OF PAMs AND SURFACE WATERS IS REQUIRED.
7. SUPPLIER TO DETERMINE APPROPRIATE PAM BASED ON SOIL TYPE.

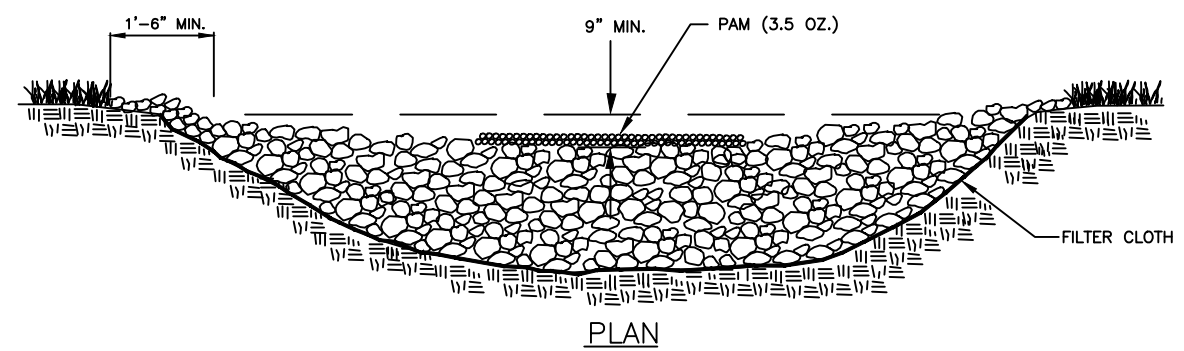
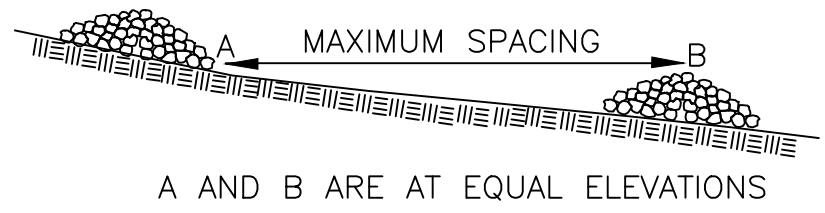
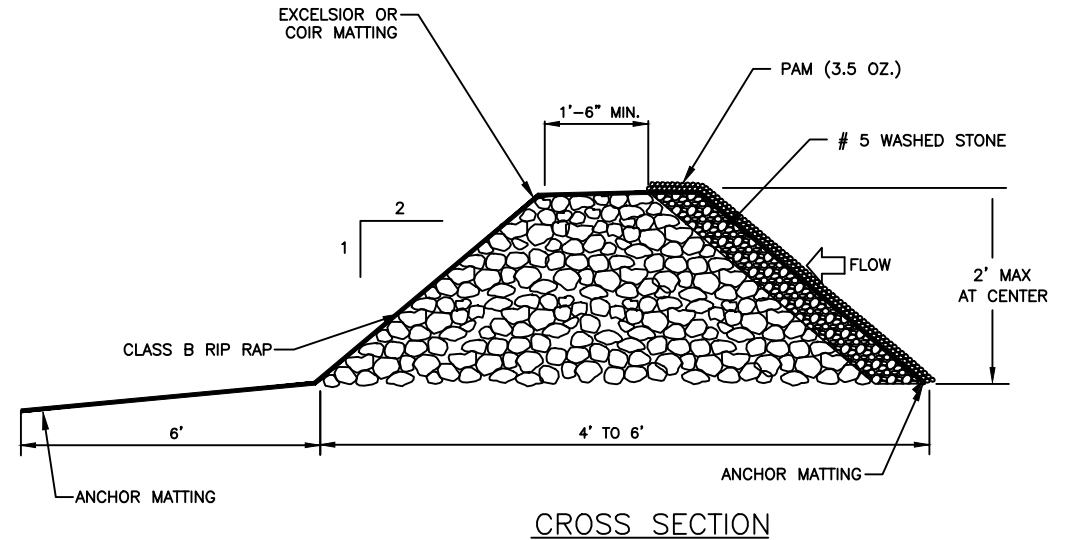

NOT TO SCALE



CITY OF CHARLOTTE
LAND DEVELOPMENT STANDARDS
 INCLUDES CHARLOTTE ETJ

**TEMPORARY ROCK CHECK DAM
 WITH MATTING AND PAM**

STD. NO.	REV.
30.10B	22

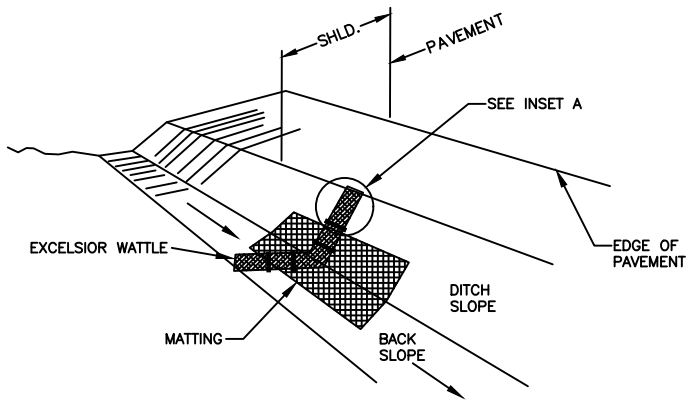

ISOMETRIC VIEW

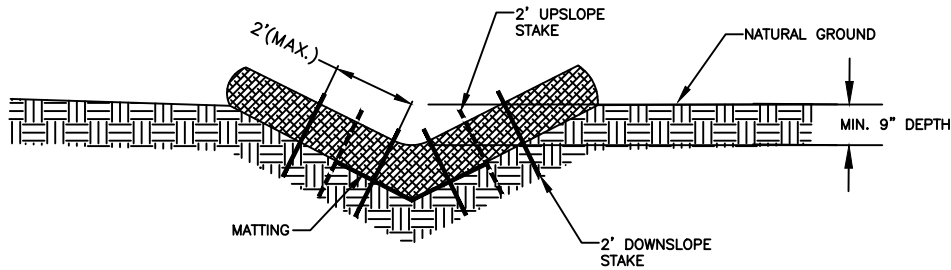

CROSS SECTION
VEE DITCH

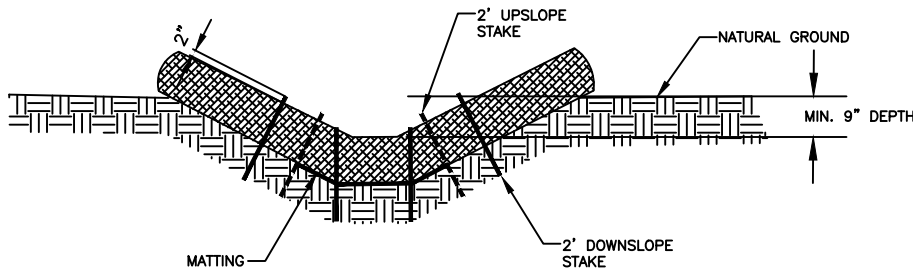

CROSS SECTION
TRAPEZOIDAL DITCH

GENERAL NOTES:

1. USE MINIMUM 12 INCH DIAMETER FIBER WATTLE.
2. USE 2 FT. WOODEN STAKES WITH A 2 IN. X 2 IN. NOMINAL CROSS SECTION
3. ONLY INSTALL WATTLE(S) TO A HEIGHT IN DITCH SO FLOW WILL NOT WASH AROUND WATTLE AND SCOUR DITCH SLOPES AND AS DIRECTED.
4. INSTALL A MINIMUM OF 2 UPSLOPE STAKES AND 4 DOWNSLOPE STAKES AT AN ANGLE TO WEDGE WATTLE TO BOTTOM OF DITCH.
5. PROVIDE STAPLES MADE OF 0.125 IN. DIAMETER STEEL WIRE FORMED INTO A U SHAPE NOT LESS THAN 12" IN LENGTH.
6. INSTALL STAPLES APPROXIMATELY EVERY 1 LINEAR FOOT ON BOTH SIDES OF WATTLE AND AT EACH END TO SECURE IT TO THE SOIL.
7. INSTALL MATTING IN ACCORDANCE WITH SECTION 1631 OF THE NCDOT STANDARD SPECIFICATIONS.

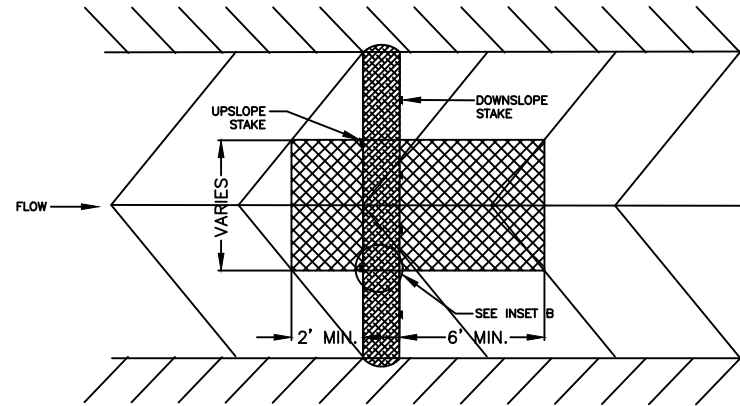
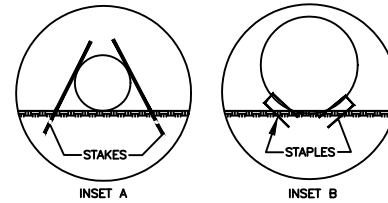

NOT TO SCALE



CITY OF CHARLOTTE
LAND DEVELOPMENT STANDARDS
INCLUDES CHARLOTTE ETJ

TEMPORARY WATTLE CHECK DAM
WITH MATTING

STD. NO.	REV.
30.10C	24

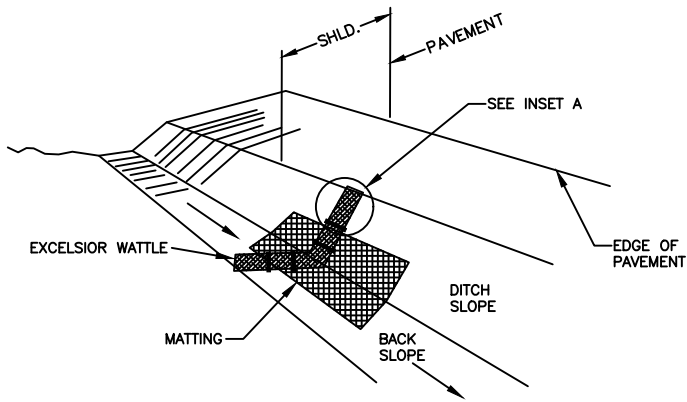

ISOMETRIC VIEW

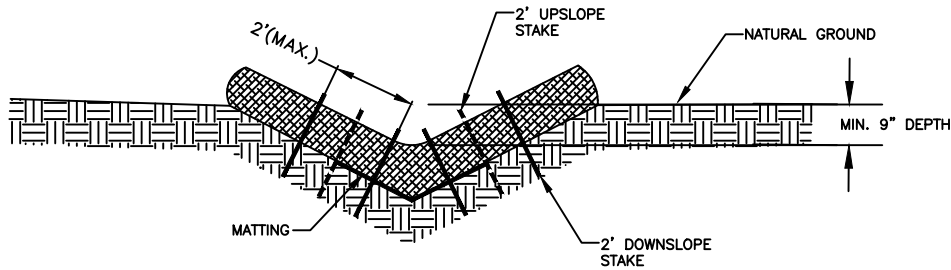

CROSS SECTION
VEE DITCH

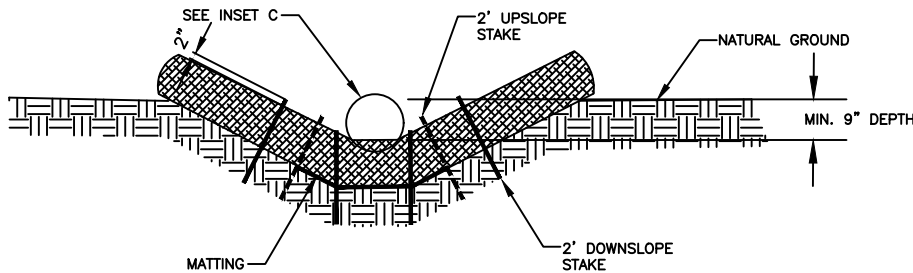

CROSS SECTION
TRAPEZOIDAL DITCH

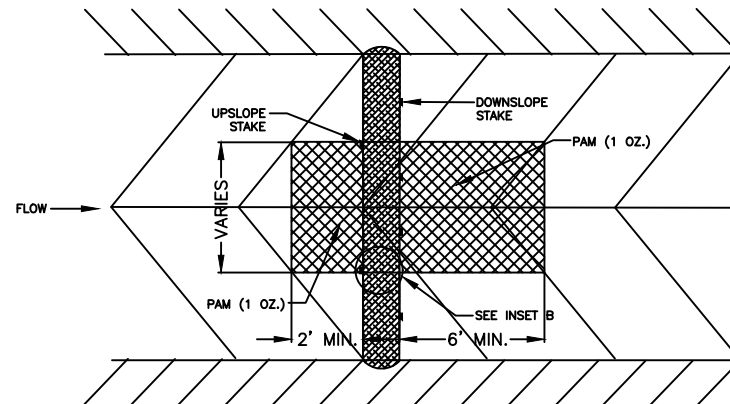
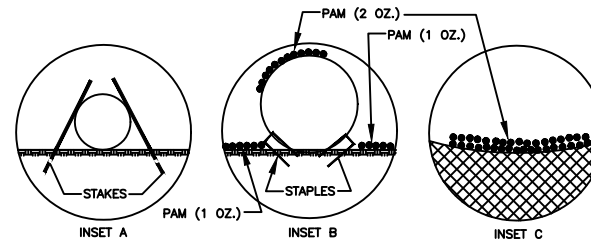

GENERAL NOTES:

1. USE MINIMUM 12 INCH DIAMETER FIBER WATTLE.
2. USE 2 FT. WOODEN STAKES WITH A 2 IN. X 2 IN. NOMINAL CROSS SECTION
3. ONLY INSTALL WATTLE(S) TO A HEIGHT IN DITCH SO FLOW WILL NOT WASH AROUND WATTLE AND SCOUR DITCH SLOPES AND AS DIRECTED.
4. INSTALL A MINIMUM OF 2 UPSLOPE STAKES AND 4 DOWNSLOPE STAKES AT AN ANGLE TO WEDGE WATTLE TO BOTTOM OF DITCH.
5. PROVIDE STAPLES MADE OF 0.125 IN. DIAMETER STEEL WIRE FORMED INTO A U SHAPE NOT LESS THAN 12" IN LENGTH.
6. INSTALL STAPLES APPROXIMATELY EVERY 1 LINEAR FOOT ON BOTH SIDES OF WATTLE AND AT EACH END TO SECURE IT TO THE SOIL.
7. INSTALL MATTING IN ACCORDANCE WITH SECTION 1631 OF THE NCDOT STANDARD SPECIFICATIONS.
8. PRIOR TO POLYACRYLAMIDE (PAM) APPLICATION, OBTAIN A SOIL SAMPLE FROM PROJECT LOCATION, AND FROM OFFSITE MATERIAL, AND ANALYZE FOR APPROPRIATE PAM FLOCCULANT TO BE APPLIED TO EACH WATTLE.
9. INITIALLY APPLY 2 OUNCES OF ANIONIC OR NEUTRALLY CHARGED PAM OVER WATTLE WHERE WATER WILL FLOW AND 1 OUNCE ON MATTING ON EACH SIDE OF WATTLE. REAPPLY PAM AFTER EVERY RAINFALL EVENT THAT IS EQUAL TO OR EXCEEDS 0.50 IN.

NOT TO SCALE



CITY OF CHARLOTTE
LAND DEVELOPMENT STANDARDS
INCLUDES CHARLOTTE ETJ

TEMPORARY WATTLE CHECK DAM
WITH MATTING AND PAM

STD. NO.	REV.
30.10D	24

NOTES:

1. A STABILIZED ENTRANCE PAD SHALL BE LOCATED WHERE TRAFFIC WILL ENTER OR LEAVE THE CONSTRUCTION SITE ONTO A PUBLIC STREET.
2. FILTER FABRIC OR COMPACTED CRUSHER RUN STONE SHALL BE USED AS A BASE FOR THE CONSTRUCTION ENTRANCE.
3. THICKNESS OF GRAVEL PAD WILL BE A MINIMUM OF 6", COMPRISED OF 2-3" COARSE AGGREGATE.
4. DIMENSION OF GRAVEL PAD WILL BE A MINIMUM OF 100' IN LENGTH AND 18' IN WIDTH.
5. CDOT MAY REQUIRE A STANDARD COMMERCIAL DRIVEWAY (STD. 10.24 & 10.25) TO ACCESS THE CONSTRUCTION SITE IF THE DRIVEWAY IS ON A THOROUGHFARE, OR ON ANY STREET WITH AN EXISTING SIDEWALK TO REMAIN OPEN DURING CONSTRUCTION.
6. FOLLOW WORK AREA TRAFFIC CONTROL HANDBOOK (WATCH) FOR SIDEWALK CLOSURE OR DETOUR/DIVERSION.
7. INSTALL SILT FENCE OR OTHER BARRIER TO CONFINE TRAFFIC TO CONSTRUCTION ENTRANCE.

MAINTENANCE NOTES:

1. THE ENTRANCE SHALL BE MAINTAINED IN A CONDITION WHICH WILL PREVENT TRACKING OR FLOWING OF SEDIMENT ONTO PUBLIC STREETS OR EXISTING PAVEMENT. THIS MAY REQUIRE PERIODIC TOP DRESSING WITH ADDITIONAL STONE AS CONDITIONS WARRANT AND REPAIR OR CLEANOUT OF ANY MEASURES USED TO TRAP SEDIMENT.
2. ANY SEDIMENT SPILLED, DROPPED, WASHED, OR TRACKED ONTO PUBLIC STREETS MUST BE REMOVED IMMEDIATELY. ANY AGGREGATE TRACKED INTO THE ROADWAY MUST BE SWEEPED BACK ONSITE ON A NIGHTLY BASIS.
3. WHEN APPROPRIATE, WHEELS MUST BE CLEANED TO REMOVE SEDIMENT PRIOR TO ENTERING A PUBLIC STREET. WHEN WASHING IS REQUIRED, IT SHALL BE DONE IN AN AREA STABILIZED WITH CRUSHED STONE WHICH DRAINS INTO AN APPROVED SEDIMENT BASIN SEE STD. NO. 30.11B.

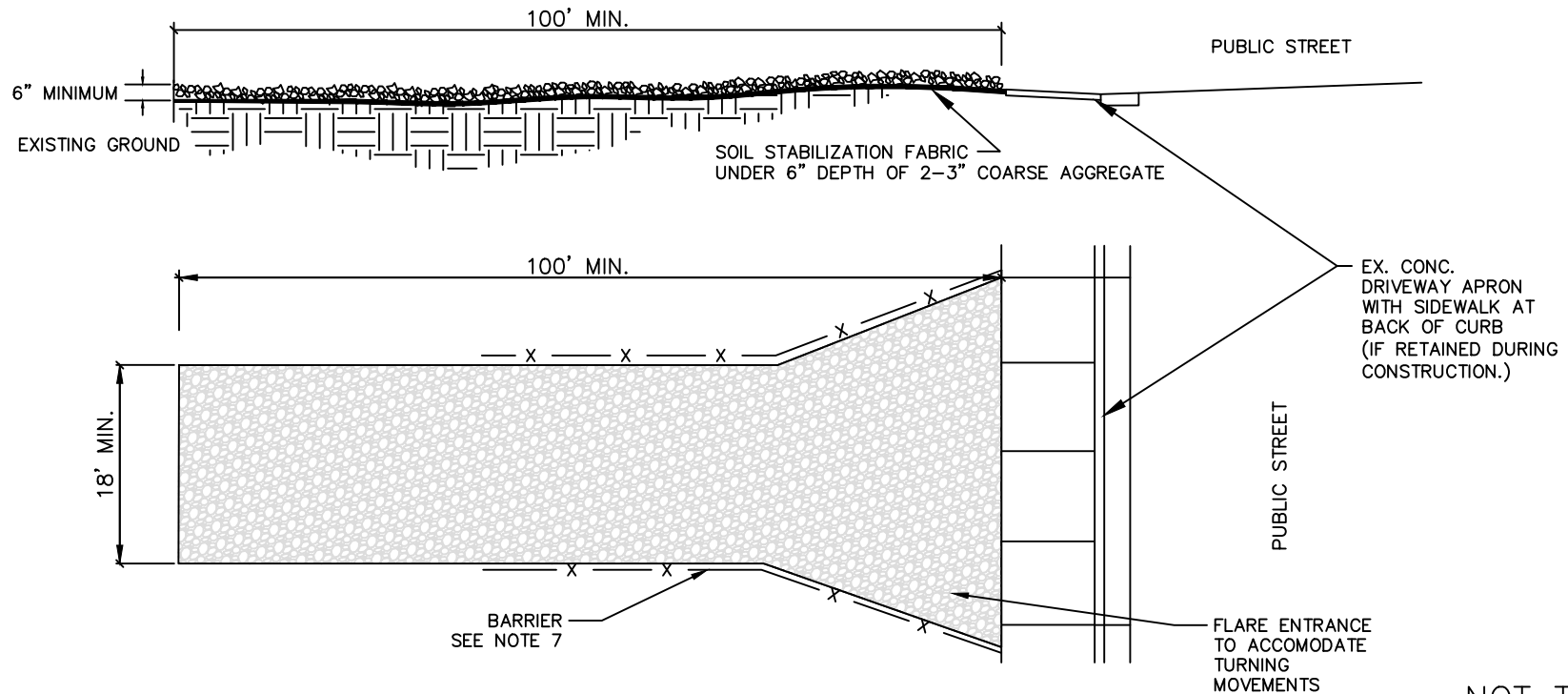

NOT TO SCALE



CITY OF CHARLOTTE
 LAND DEVELOPMENT STANDARDS
 INCLUDES CHARLOTTE ETJ

STABILIZED CONSTRUCTION ENTRANCE

STD. NO.	REV.
30.11A	25

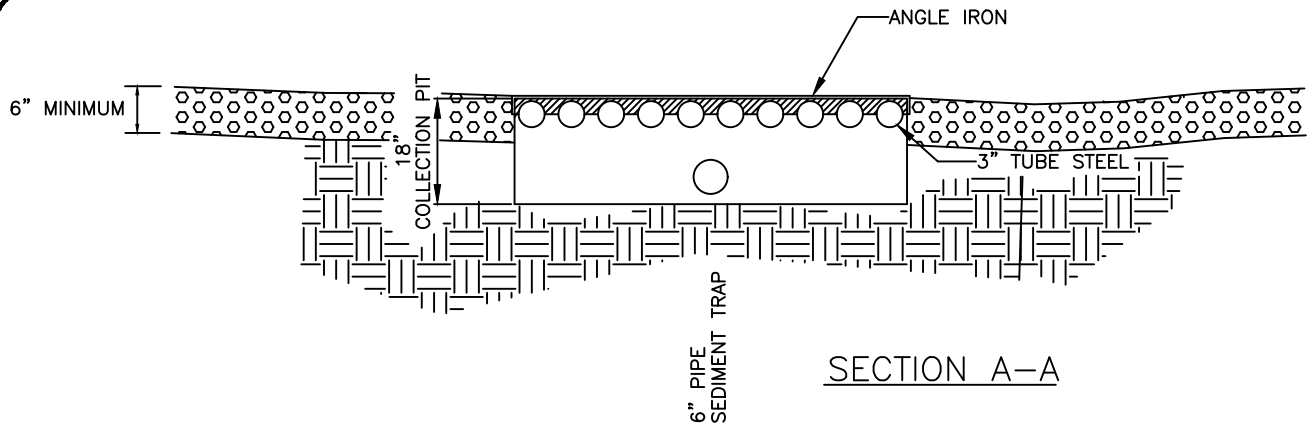

NOTE: MAY BE USED WHERE EXTENSIVE HAULING WILL BE DONE.

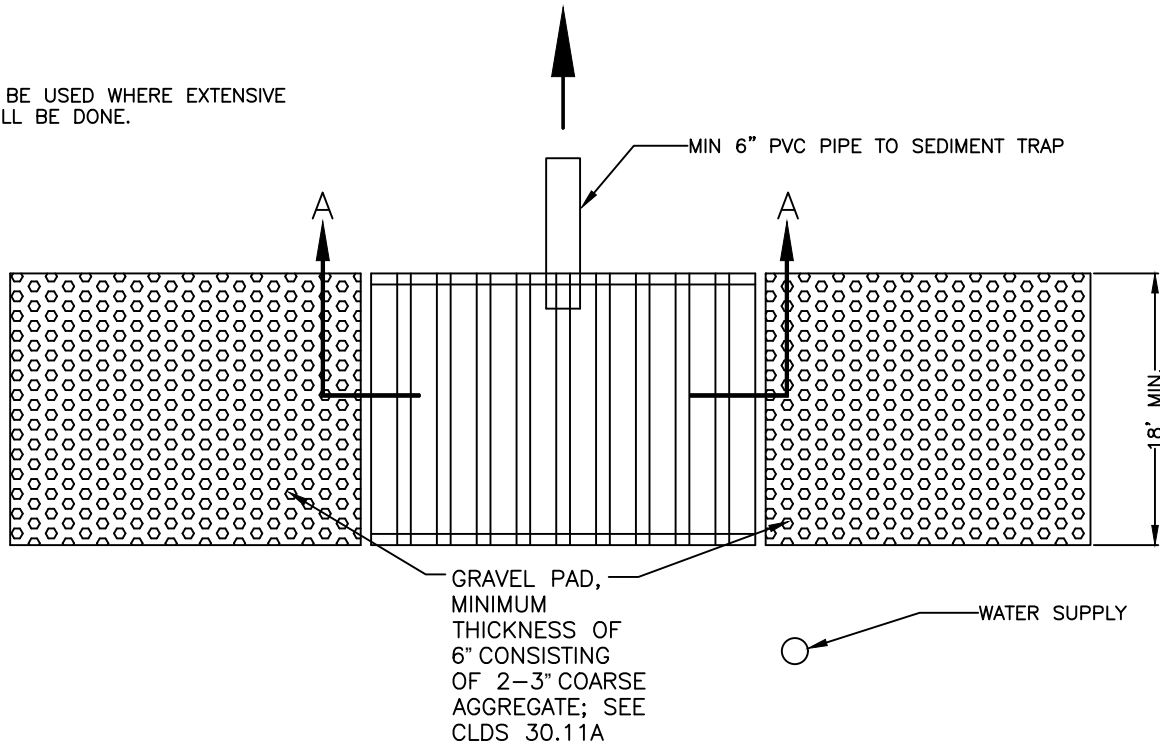

NOTES:

1. A STABILIZED ENTRANCE PAD SHALL BE LOCATED WHERE TRAFFIC WILL ENTER OR LEAVE THE CONSTRUCTION SITE ONTO A PUBLIC STREET.
2. FILTER FABRIC OR COMPACTED CRUSHER RUN STONE SHALL BE USED AS A BASE FOR THE CONSTRUCTION ENTRANCE.
3. THICKNESS OF GRAVEL PAD WILL BE A MINIMUM OF 6", COMPRISED OF 2-3" COARSE AGGREGATE.
4. DIMENSION OF GRAVEL PAD WILL BE A MINIMUM OF 100' IN LENGTH AND 18' IN WIDTH.
5. CDOT MAY REQUIRE A STANDARD COMMERCIAL DRIVEWAY (STD. 10.24 & 10.25) TO ACCESS THE CONSTRUCTION SITE IF THE DRIVEWAY IS ON A THOROUGHFARE, OR ON ANY STREET WITH AN EXISTING SIDEWALK TO REMAIN OPEN DURING CONSTRUCTION.
6. FOLLOW WORK AREA TRAFFIC CONTROL HANDBOOK (WATCH) FOR SIDEWALK CLOSURE OR DETOUR/DIVERSION.
7. INSTALL SILT FENCE OR OTHER BARRIER TO CONFINE TRAFFIC TO CONSTRUCTION ENTRANCE.

MAINTENANCE NOTES:

1. THE ENTRANCE SHALL BE MAINTAINED IN A CONDITION WHICH WILL PREVENT TRACKING OR FLOWING OF SEDIMENT ONTO PUBLIC STREETS OR EXISTING PAVEMENT. THIS MAY REQUIRE PERIODIC TOP DRESSING WITH ADDITIONAL STONE AS CONDITIONS WARRANT AND REPAIR OR CLEANOUT OF ANY MEASURES USED TO TRAP SEDIMENT.
2. ANY SEDIMENT SPILLED, DROPPED, WASHED, OR TRACKED ONTO PUBLIC STREETS MUST BE REMOVED IMMEDIATELY. ANY AGGREGATE TRACKED INTO THE ROADWAY MUST BE SWEEPED BACK ONSITE ON A NIGHTLY BASIS.
3. WHEN APPROPRIATE, WHEELS MUST BE CLEANED TO REMOVE SEDIMENT PRIOR TO ENTERING A PUBLIC STREET. WHEN WASHING IS REQUIRED, IT SHALL BE DONE IN AN AREA STABILIZED WITH CRUSHED STONE WHICH DRAINS INTO AN APPROVED SEDIMENT BASIN.

NOT TO SCALE



CITY OF CHARLOTTE
 LAND DEVELOPMENT STANDARDS
 INCLUDES CHARLOTTE ETJ

CONSTRUCTION ENTRANCE
 TIRE WASH

STD. NO.	REV.
30.11B	25

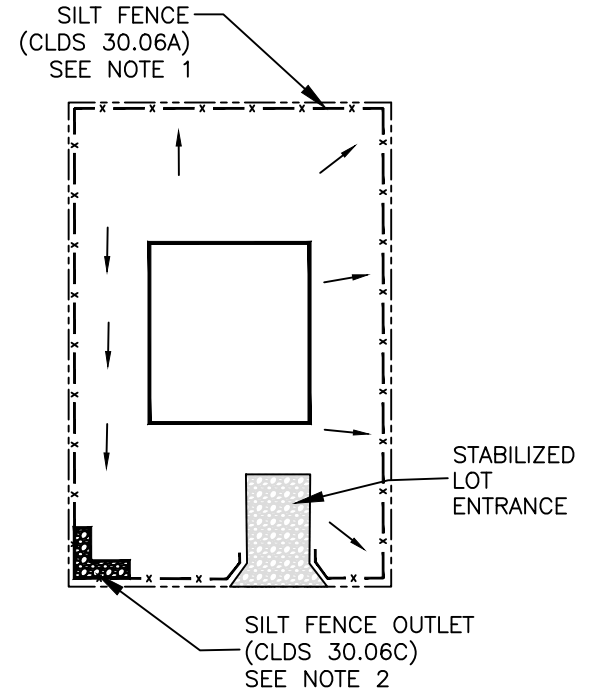
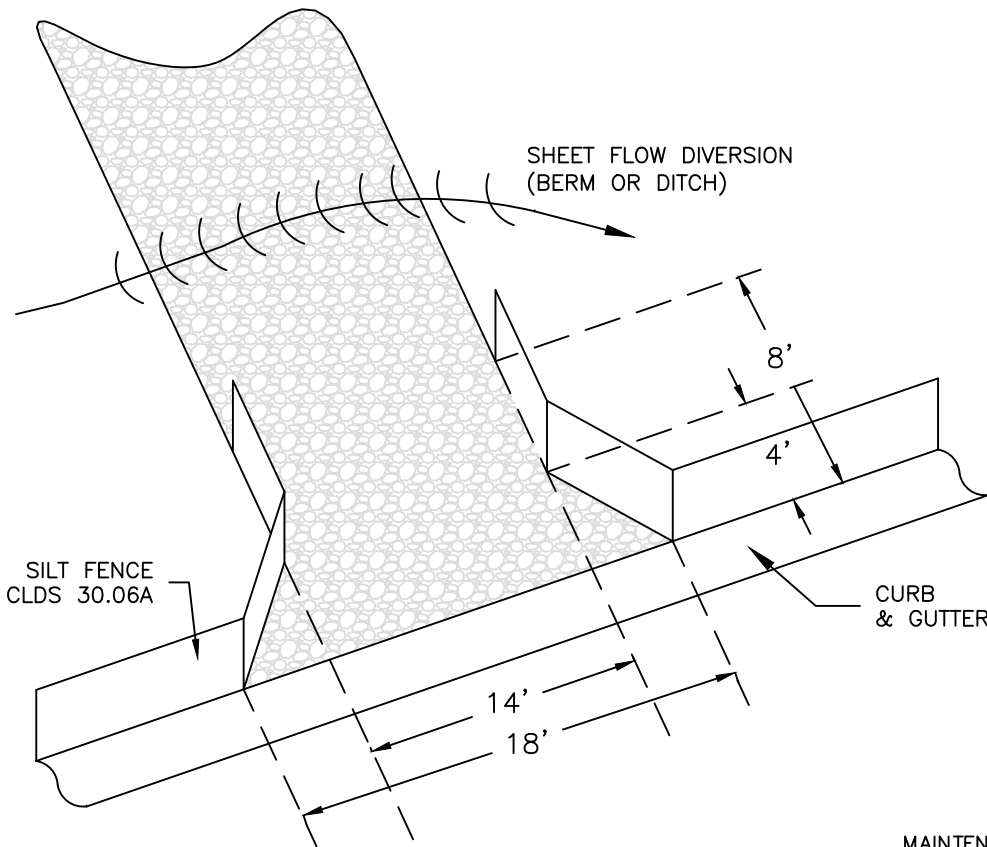

PLAN VIEW

NOTES:

1. SILT FENCE REQUIRED ON PERIMETER WHERE NECESSARY TO CONTAIN SEDIMENT TO THE LOT UNDER ACTIVE CONSTRUCTION.
2. SILT FENCE OUTLET SHALL BE INSTALLED WITH CONSIDERATION OF EXISTING OR PROPOSED LOT DRAINAGE SWALES.
3. PROVIDE 6" MINIMUM STONE DEPTH
4. USE 2-3" COARSE AGGREGATE
5. INSTALL SOIL STABILIZATION FABRIC OR 4" COMPACTED ABC STONE UNDER ENTRANCE
6. TYPICAL LENGTH OF ENTRANCE = 25' (UNLESS LIMITED BY LOT CONFIGURATION).
7. REFERENCE CLDS 30.06A FOR SILT FENCE INSTALLATION AND MAINTENANCE.
8. REFERENCE CLDS 30.06C FOR SILT FENCE OUTLET INSTALLATION AND MAINTENANCE.

MAINTENANCE NOTES:

1. THE ENTRANCE SHALL BE MAINTAINED IN A CONDITION WHICH WILL PREVENT TRACKING OR FLOWING OF SEDIMENT ONTO PUBLIC STREETS OR EXISTING PAVEMENT. THIS MAY REQUIRE PERIODIC TOP DRESSING WITH ADDITIONAL STONE AS CONDITIONS WARRANT AND REPAIR OR CLEANOUT OF ANY MEASURES USED TO TRAP SEDIMENT.
2. ANY SEDIMENT SPILLED, DROPPED, WASHED, OR TRACKED ONTO PUBLIC STREETS MUST BE REMOVED IMMEDIATELY. ANY AGGREGATE TRACKED INTO THE ROADWAY MUST BE SWEEPED BACK ONSITE ON A NIGHTLY BASIS.
3. WHEN APPROPRIATE, WHEELS MUST BE CLEANED TO REMOVE SEDIMENT PRIOR TO ENTERING A PUBLIC STREET. WHEN WASHING IS REQUIRED, IT SHALL BE DONE IN AN AREA STABILIZED WITH CRUSHED STONE WHICH DRAINS INTO AN APPROVED SEDIMENT BASIN SEE STD. NO. 30.11B.



**CITY OF CHARLOTTE
LAND DEVELOPMENT STANDARDS**
INCLUDES CHARLOTTE ETJ

SINGLE FAMILY LOT CONTROLS

NOT TO SCALE

STD. NO.	REV.
30.11C	25

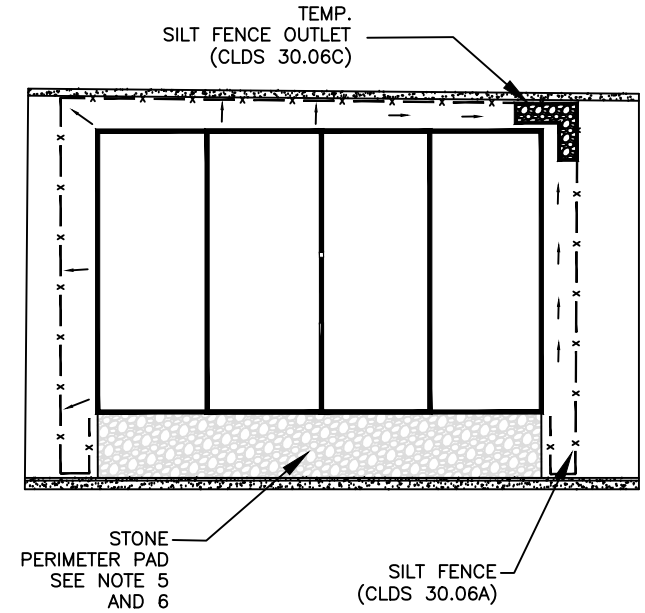
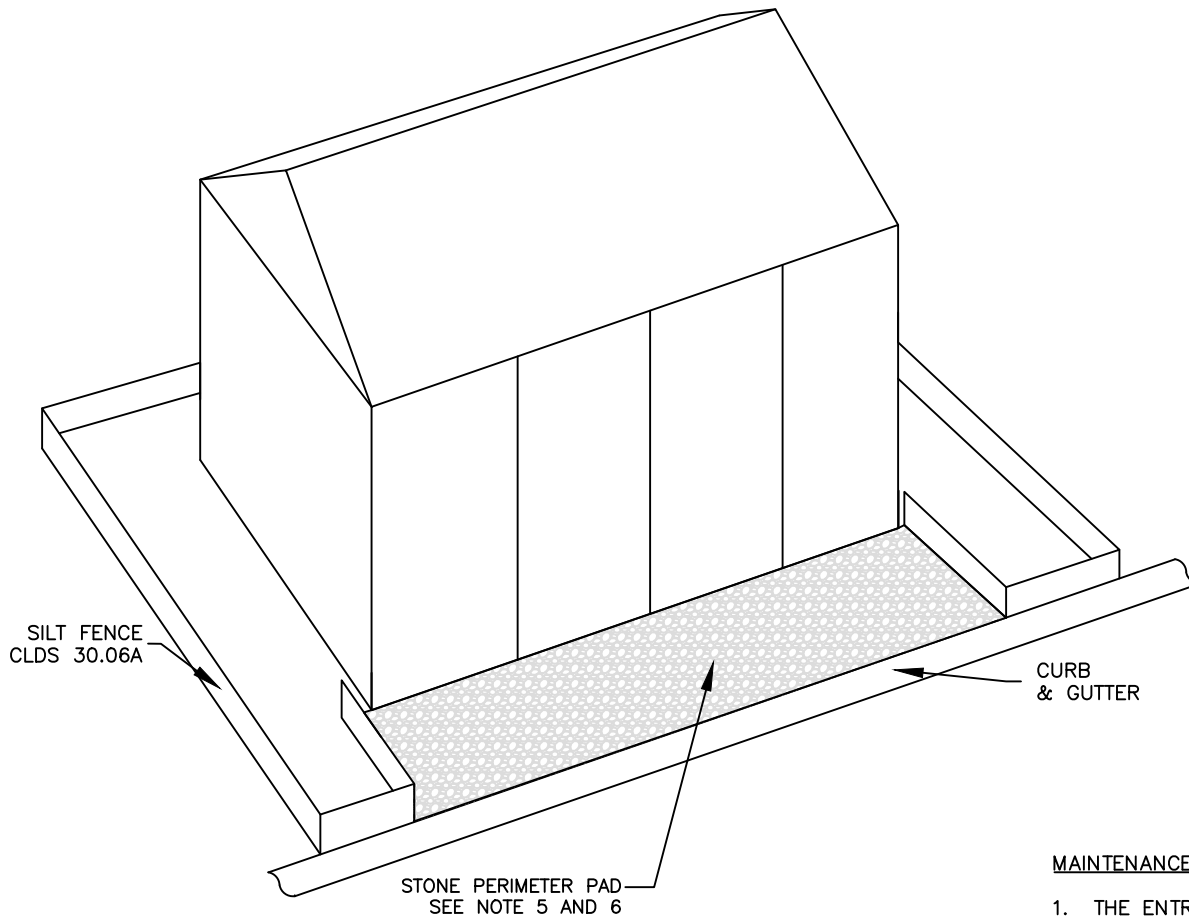

PLAN VIEW

NOTES:

1. SILT FENCE REQUIRED ON PERIMETER WHERE NECESSARY TO CONTAIN SEDIMENT TO THE LOT OR BLOCK UNDER ACTIVE CONSTRUCTION.
2. SILT FENCE OUTLET SHALL BE INSTALLED WITH CONSIDERATION OF EXISTING OR PROPOSED LOT DRAINAGE SWALES.
3. REFERENCE CLDS 30.06A FOR SILT FENCE INSTALLATION AND MAINTENANCE.
4. REFERENCE CLDS 30.06C FOR SILT FENCE OUTLET INSTALLATION AND MAINTENANCE.
5. STONE PERIMETER PAD MUST BE PLACED FROM BACK OF CURB TO BUILDING.
6. INSTALL 6" OF 2-3" COARSE AGGREGATE PER CONSTRUCTION ENTRANCE DETAIL 30.11A AS NECESSARY TO PROTECT SITE FROM SEDIMENT TRACK-OUT.

MAINTENANCE NOTES:

1. THE ENTRANCE SHALL BE MAINTAINED IN A CONDITION WHICH WILL PREVENT TRACKING OR FLOWING OF SEDIMENT ONTO PUBLIC STREETS OR EXISTING PAVEMENT. THIS MAY REQUIRE PERIODIC TOP DRESSING WITH ADDITIONAL STONE AS CONDITIONS WARRANT AND REPAIR OR CLEANOUT OF ANY MEASURES USED TO TRAP SEDIMENT.
2. ANY SEDIMENT SPILLED, DROPPED, WASHED, OR TRACKED ONTO PUBLIC STREETS MUST BE REMOVED IMMEDIATELY. ANY AGGREGATE TRACKED INTO THE ROADWAY MUST BE SWEEPED BACK ONSITE ON A NIGHTLY BASIS.
3. WHEN APPROPRIATE, WHEELS MUST BE CLEANED TO REMOVE SEDIMENT PRIOR TO ENTERING A PUBLIC STREET. WHEN WASHING IS REQUIRED, IT SHALL BE DONE IN AN AREA STABILIZED WITH CRUSHED STONE WHICH DRAINS INTO AN APPROVED SEDIMENT BASIN SEE STD. NO. 30.11B.



**CITY OF CHARLOTTE
LAND DEVELOPMENT STANDARDS**
INCLUDES CHARLOTTE ETJ

URBAN BLOCK/LOT CONTROLS

NOT TO SCALE

STD. NO.	REV.
30.11D	25

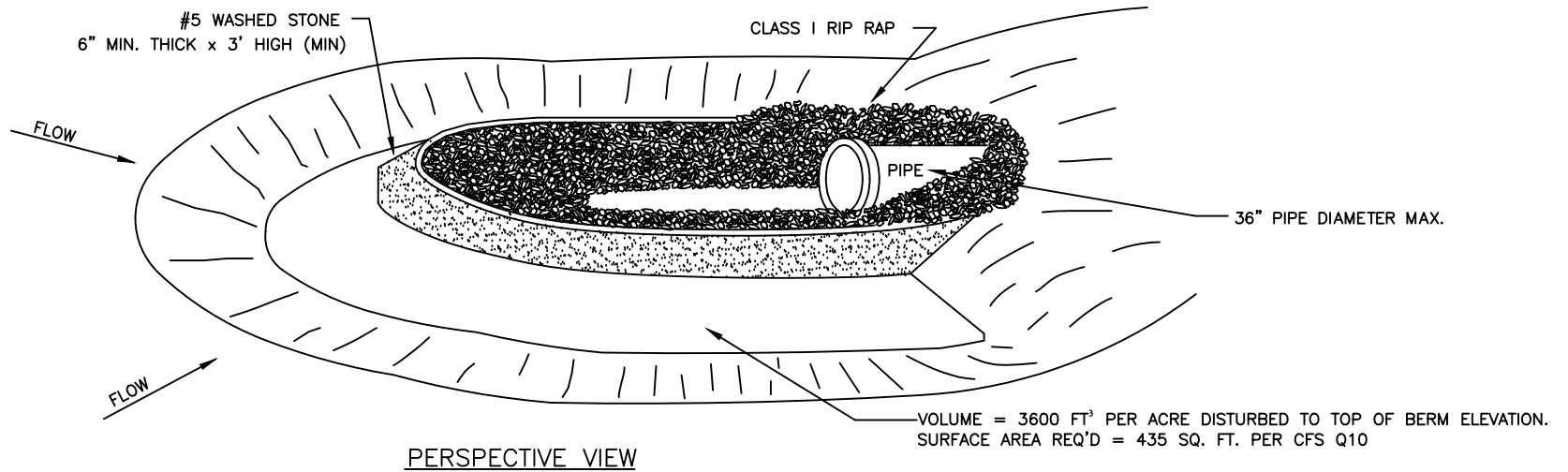

GENERAL NOTES:

1. GRAVEL AND RIP RAP FILTER BERM BASIN SHOULD BE USED TO PROTECT EXISTING PIPE INVERTS.
2. DIMENSIONS SHOWN ARE THE MINIMUM ACCEPTED UNLESS OTHERWISE NOTED.
3. CLEANOUT PRIOR TO SEDIMENT REACHING HALF OF BERM HEIGHT.
4. MAY BE USED AT PIPES WITH MAX. DIAMETER OF 36".

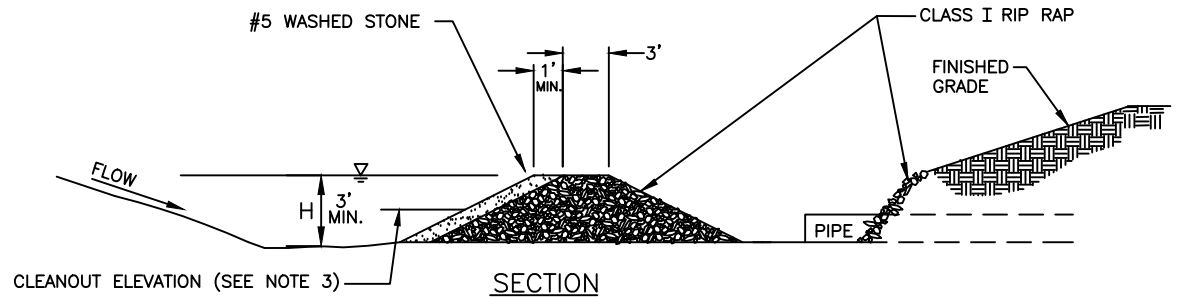

NOT TO SCALE



CITY OF CHARLOTTE
LAND DEVELOPMENT STANDARDS
INCLUDES CHARLOTTE ETJ

GRAVEL AND RIP RAP FILTER BERM BASIN

STD. NO.	REV.
30.12	19

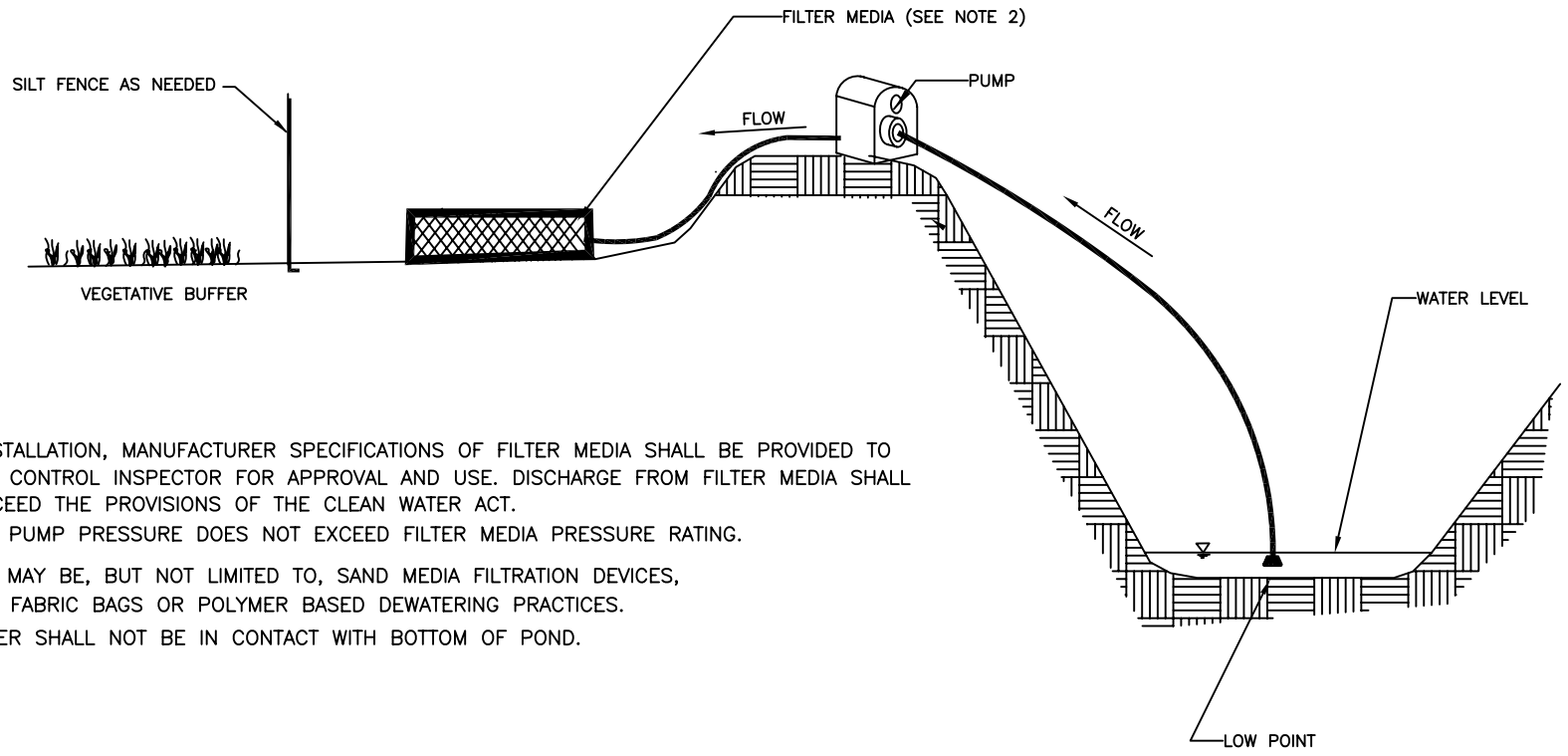

NOTE:

1. PRIOR TO INSTALLATION, MANUFACTURER SPECIFICATIONS OF FILTER MEDIA SHALL BE PROVIDED TO THE EROSION CONTROL INSPECTOR FOR APPROVAL AND USE. DISCHARGE FROM FILTER MEDIA SHALL MEET OR EXCEED THE PROVISIONS OF THE CLEAN WATER ACT.
2. ENSURE THAT PUMP PRESSURE DOES NOT EXCEED FILTER MEDIA PRESSURE RATING.
3. FILTER MEDIA MAY BE, BUT NOT LIMITED TO, SAND MEDIA FILTRATION DEVICES, RATED FILTER FABRIC BAGS OR POLYMER BASED DEWATERING PRACTICES.
4. PUMP STRAINER SHALL NOT BE IN CONTACT WITH BOTTOM OF POND.

NOT TO SCALE



CITY OF CHARLOTTE
 LAND DEVELOPMENT STANDARDS
 INCLUDES CHARLOTTE ETJ

EROSION CONTROL DEWATERING

STD. NO.	REV.
30.13	

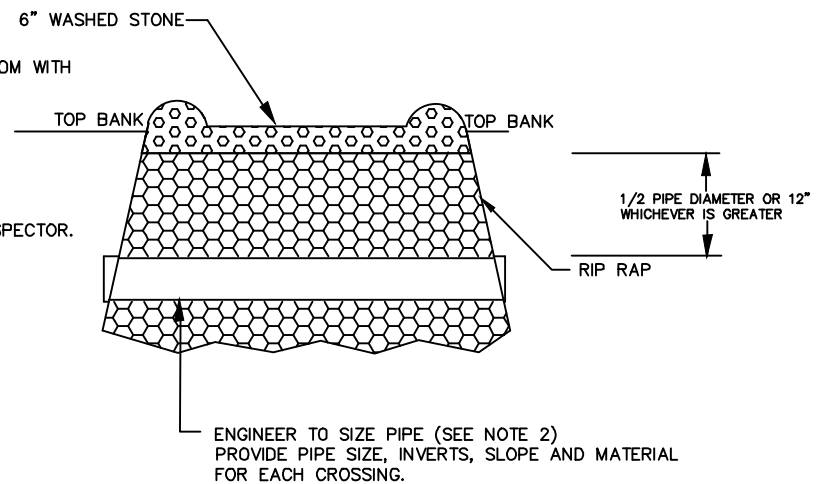
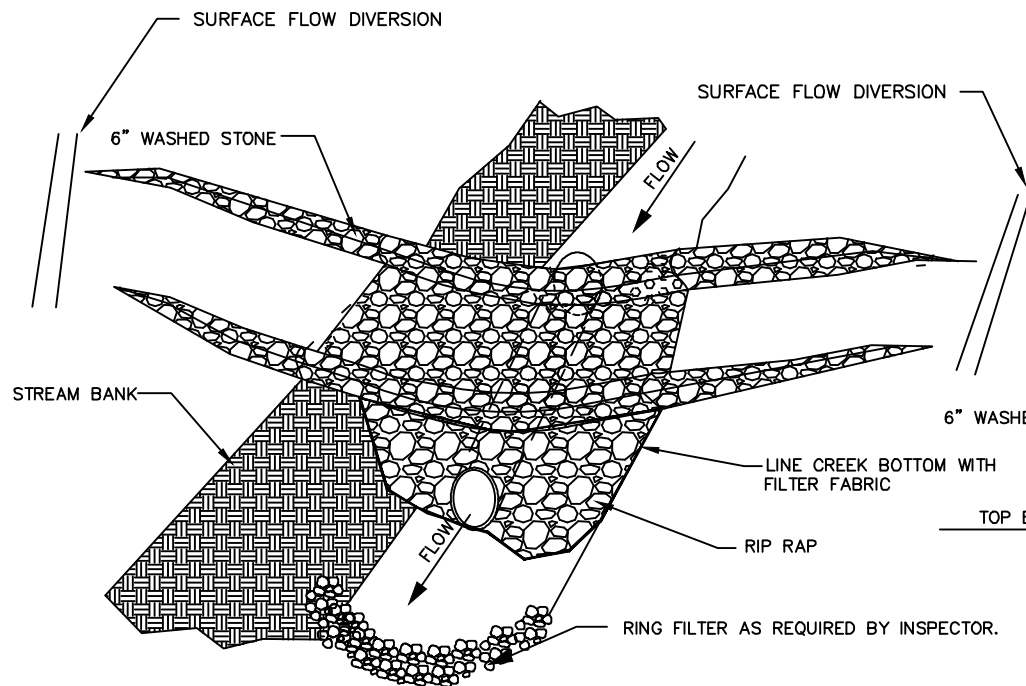

NOTES:

1. REMOVE THE STRUCTURE WHEN NO LONGER NEEDED. (NOT TO EXCEED 1 YEAR).
2. AS A MINIMUM, DESIGN THE STRUCTURE TO PASS 2 YEAR PEAK FLOW WITHOUT OVERTOPPING.
3. ENSURE THAT DESIGN FLOW VELOCITY AT THE OUTLET OF THE CROSSING STRUCTURE IS NON-EROSIVE FOR THE RECEIVING STREAM CHANNEL.
4. ADDITIONAL MEASURES MAY BE REQUIRED BY THE EROSION CONTROL COORDINATOR OR CITY ENGINEER BASED ON SITE SPECIFIC CONDITIONS.

NOT TO SCALE



CITY OF CHARLOTTE
LAND DEVELOPMENT STANDARDS
INCLUDES CHARLOTTE ETJ

TEMPORARY STREAM CROSSING

STD. NO.	REV.
30.14	15

NOTES:

1. INLET MAINTENANCE SHALL BE DOCUMENTED IN PROJECT LOG BOOK.
2. FILTER TYPES SHALL BE APPROVED BY THE CITY INSPECTOR PRIOR TO INSTALLATION.
3. FILTER BAGS MAY BE REMOVED WHEN SITE IS STABILIZED AT THE DIRECTION OF THE ENGINEER.
4. FILTER BAGS SHALL BE REMOVED PRIOR TO STREET ACCEPTANCE AND/OR CLOSE OUT OF GRADING PERMIT.
5. FILTER BAGS SHALL BE CLEANED OR REPLACED ON A REGULAR BASIS (NOT BE MORE THAN HALF FULL AT ANY TIME).
6. FILTER BAGS MAY BE INSTALLED IN EXISTING CITY OR NCDOT ROADS AS LONG AS STORM DRAINAGE IS NOT IMPEDED.

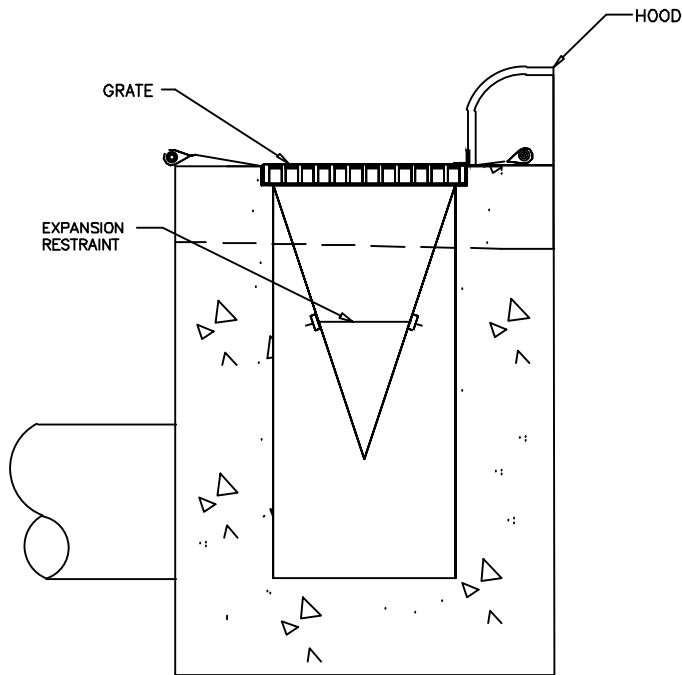

SECTION

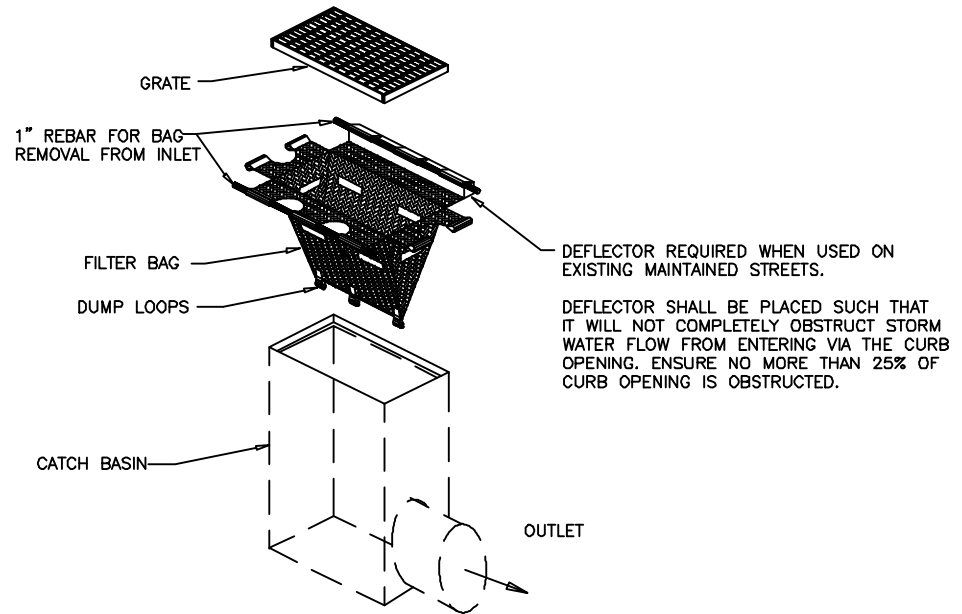

INSTALLATION

NOT TO SCALE



CITY OF CHARLOTTE
LAND DEVELOPMENT STANDARDS
 INCLUDES CHARLOTTE ETJ

CATCH BASIN INLET PROTECTION

STD. NO.	REV.
30.15	13

ALTERNATIVE 1:

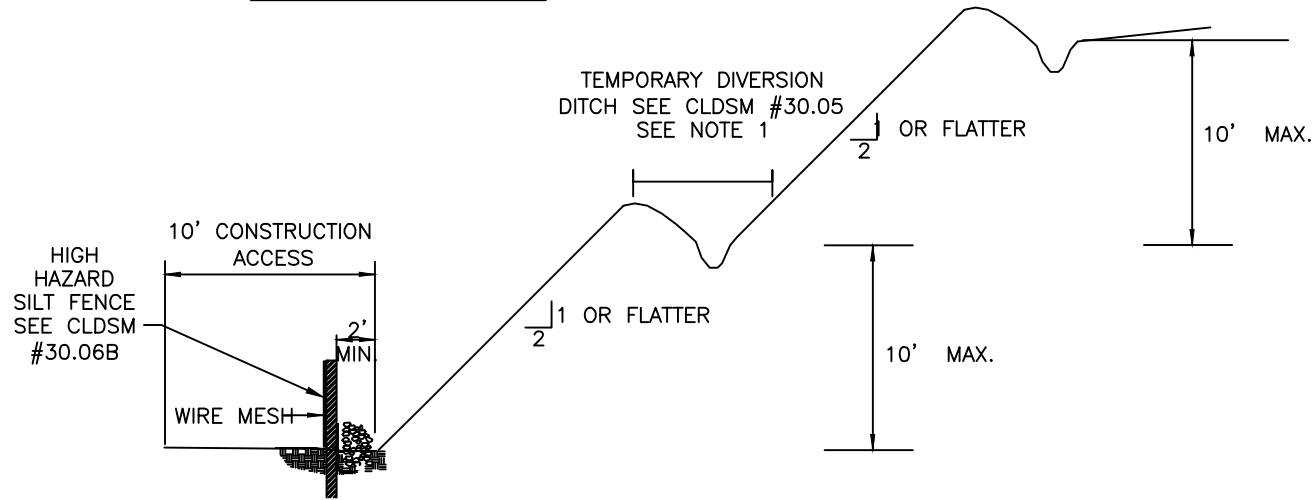

NOTES:

1. IF DIVERSION DITCH USED, IT SHOULD FLOW INTO SEDIMENT BASIN ROCK CHECK DAM, OR SLOPE DRAIN
2. BENCH SHOULD BE GRADED AT 0% LONGITUDINAL SLOPE (ON-CONTOUR)

ALTERNATIVE 2:

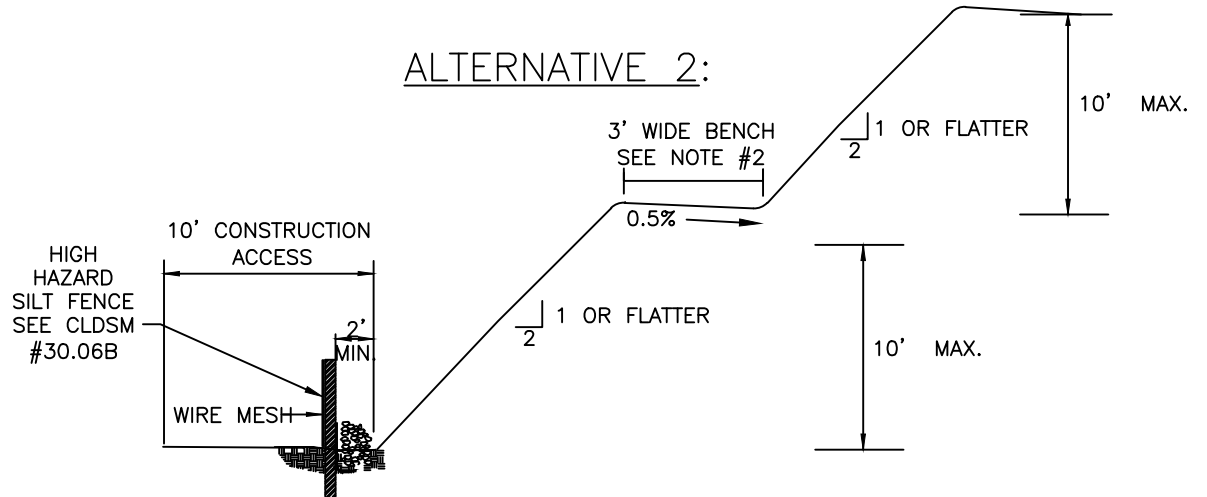

NOT TO SCALE



CITY OF CHARLOTTE
LAND DEVELOPMENT STANDARDS
INCLUDES CHARLOTTE ETJ

SLOPE STABILITY

STD. NO.	REV.
30.16	12

FOR LATE WINTER AND EARLY SPRING:

SEEDING MIXTURE:

RYE (GRAIN) – 120 LB/ACRE
ANNUAL LESPEDEZA (KOBE) – 50 LB/ACRE
(OMIT ANNUAL LESPEDEZA WHEN DURATION OF TEMPORARY COVER IS NOT TO EXTEND BEYOND JUNE)

SEEDING DATES:

JAN. 1 – MAY 1

SOIL AMENDMENTS:

FOLLOW RECOMMENDATIONS OF SOIL TESTS OR APPLY 2,000 LB/ACRE GROUND AGRICULTURAL LIMESTONE AND 750 LB/ACRE 10-10-10 FERTILIZER

MULCH:

APPLY 4,000 LB/ACRE STRAW. ANCHOR STRAW BY TACKING WITH ASPHALT, NETTING, OR A MULCH ANCHORING TOOL. A DISK WITH BLADES SET NEARLY STRAIGHT CAN BE USED AS A MULCH ANCHORING TOOL

MAINTENANCE:

REFERTILIZE IF GROWTH IS NOT FULLY ADEQUATE. RESEED, FERTILIZE AND MULCH IMMEDIATELY FOLLOWING EROSION OR OTHER DAMAGE

FOR SUMMER:

SEEDING MIXTURE:

GERMAN MILLET – 40 LB/ACRE
(A SMALL-STEMMED SUDANGRASS MAY BE SUBSTITUTED AT A RATE OF 50 LB/ACRE)

SEEDING DATES:

MAY 1 – AUG. 15

SOIL AMENDMENTS:

FOLLOW RECOMMENDATIONS OF SOIL TESTS OR APPLY 2,000 LB/ACRE GROUND AGRICULTURAL LIMESTONE AND 750 LB/ACRE 10-10-10 FERTILIZER

MULCH:

APPLY 4,000 LB/ACRE STRAW. ANCHOR STRAW BY TACKING WITH ASPHALT, NETTING, OR A MULCH ANCHORING TOOL. A DISK WITH BLADES SET NEARLY STRAIGHT CAN BE USED AS A MULCH ANCHORING TOOL

MAINTENANCE:

REFERTILIZE IF GROWTH IS NOT FULLY ADEQUATE. RESEED, FERTILIZE AND MULCH IMMEDIATELY FOLLOWING EROSION OR OTHER DAMAGE

FOR FALL:

SEEDING MIXTURE:

RYE (GRAIN) – 120 LB/ACRE

SEEDING DATES:

AUG. 15 – DEC 30

SOIL AMENDMENTS:

FOLLOW RECOMMENDATIONS OF SOIL TESTS OR APPLY 2,000 LB/ACRE GROUND AGRICULTURAL LIMESTONE AND 1,000 LB/ACRE 10-10-10 FERTILIZER

MULCH:

APPLY 4,000 LB/ACRE STRAW. ANCHOR STRAW BY TACKING WITH ASPHALT, NETTING, OR A MULCH ANCHORING TOOL. A DISK WITH BLADES SET NEARLY STRAIGHT CAN BE USED AS A MULCH ANCHORING TOOL

MAINTENANCE:

REPAIR AND REFERTILIZE DAMAGED AREAS IMMEDIATELY. TOPDRESS WITH 50 LB/ACRE OF NITROGEN IN MARCH. IF IT IS NECESSARY TO EXTEND TEMPORARY COVER BEYOND JUNE 15, OVERSEED WITH 50 LB/ACRE KOBE LESPEDEZA IN LATE FEBRUARY OR EARLY MARCH.

FOR ADDITIONAL INFORMATION, REFER TO NCDENR EROSION AND SEDIMENT CONTROL PLANNING AND DESIGN MANUAL (ESCPDM), SECTION 6.10. FOR PERMANENT SEEDING SPECIFICATIONS, INCLUDING SEED BED PREP, SEASONAL LIMITATIONS FOR SEEDING OPERATIONS, THE KINDS OF GRADES OF FERTILIZERS, THE KINDS OF SEED, AND THE RATES OF APPLICATION OF LIMESTONE, FERTILIZER, AND SEED, REFER TO NCDENR ESCPDM SECTION 6.11 AND THE CHARLOTTE LANDSCAPE CONSTRUCTION STANDARDS SECTION 04200 SEEDING AND SODDING OF TURFGRASS.



CITY OF CHARLOTTE
LAND DEVELOPMENT STANDARDS
INCLUDES CHARLOTTE ETJ

TEMPORARY SEEDING SCHEDULE

STD. NO. REV.

30.17 9

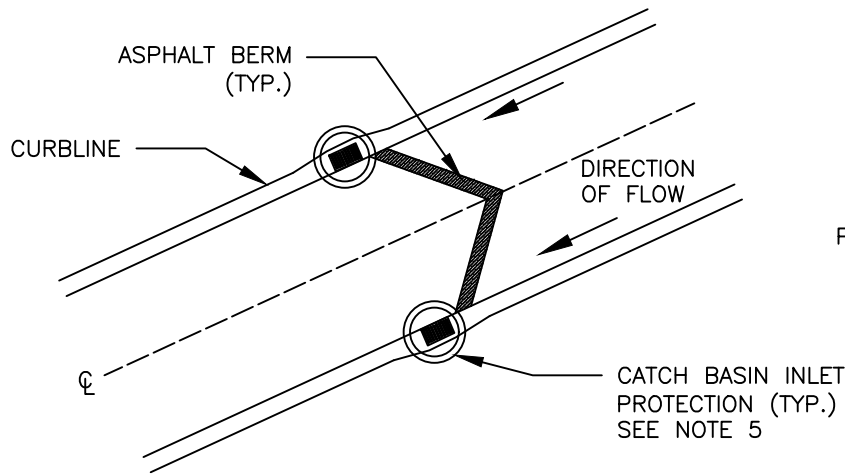

OPTION 1
CATCH BASINS ALIGNED
ACROSS STREET

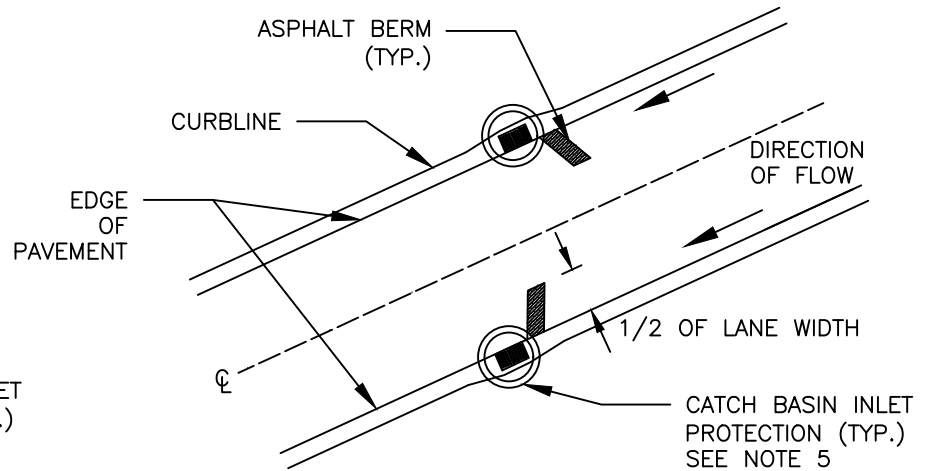

OPTION 2
CATCH BASINS OFFSET OR
INDIVIDUAL CATCH BASIN

NOTES:

1. TEMPORARY BERMS ARE INSTALLED TO ACHIEVE DESIGNED DRAINAGE AREAS PRIOR TO FINAL ASPHALT LIFT BEING INSTALLED ON ROAD SURFACE.
2. CONTRACTOR TO INSTALL TEMPORARY BERMS ON INTERMEDIATE COURSE, ON HIGH SIDE OF CURB INLETS FOR STRUCTURES ALONG THE STREET SLOPE.
3. REMOVE BERM PRIOR INSTALLING FINAL ASPHALT LIFT, FINISHING ROAD SURFACE.
4. REMOVE ACCUMULATED SEDIMENT FROM ABOVE BERM WEEKLY AND AFTER RAINFALL, AS NEEDED TO MAINTAIN FUNCTION.
5. CATCH BASIN INLET PROTECTION MAY BE OMITTED IF APPROVED BY EROSION CONTROL COORDINATOR

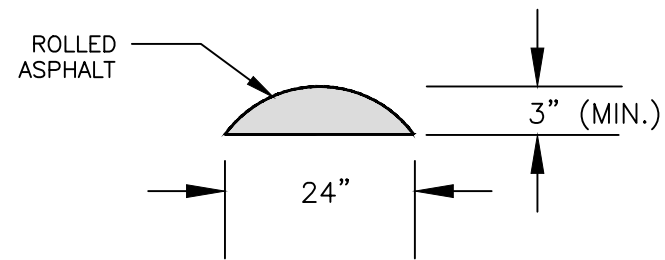

BERM CROSS SECTION

NOT TO SCALE



CITY OF CHARLOTTE
LAND DEVELOPMENT STANDARDS
INCLUDES CHARLOTTE ETJ

TEMPORARY ASPHALT DIVERSION BERM

STD. NO.	REV.
30.18	21

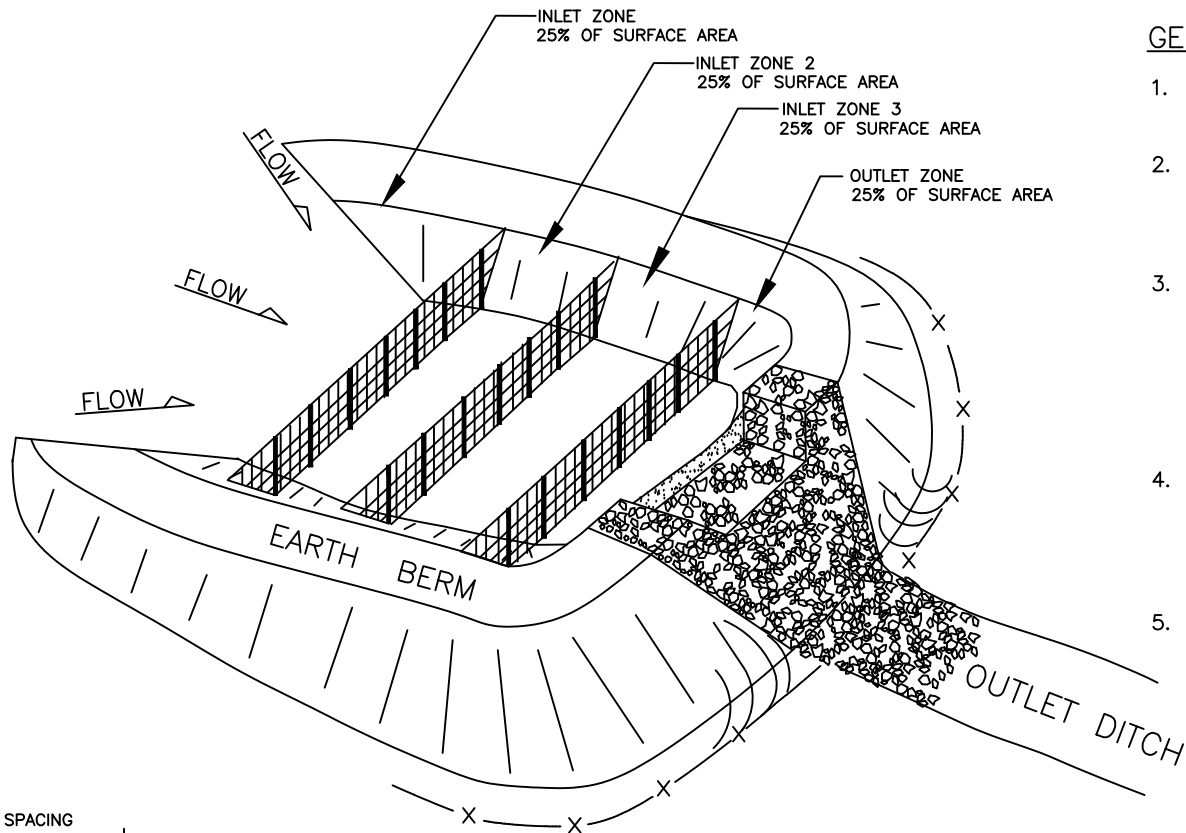

GENERAL NOTES:

1. DRIVE 5' STEEL POST AT LEAST 24" INTO SOLID GROUND.
2. USE STAPLES 1' APART HORIZONTALLY AND VERTICALLY TO ATTACH THE FILTER FABRIC TO THE WIRE FENCE.
3. PROVIDE 4 TREATMENT ZONES, 25% OF SURFACE AREA IN EACH ZONE (3 BAFFLES). FOR BASINS LESS THAN 40 FEET LONG, PROVIDE 3 TREATMENT ZONES, 33% OF SURFACE AREA EACH ZONE (2 BAFFLES)
4. THE FLOOR OF THE BASIN IN THE OUTLET ZONE AND BERMS SHOULD BE SEEDED IMMEDIATELY AFTER THE BASIN IS CONSTRUCTED.
5. REFER TO NCESCPDM SECTION #6.65 FOR ADDITIONAL SPECIFICATIONS.

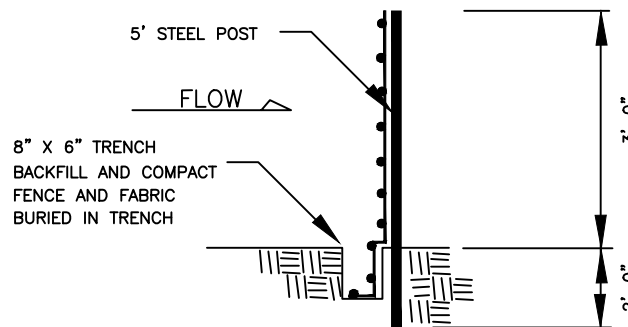
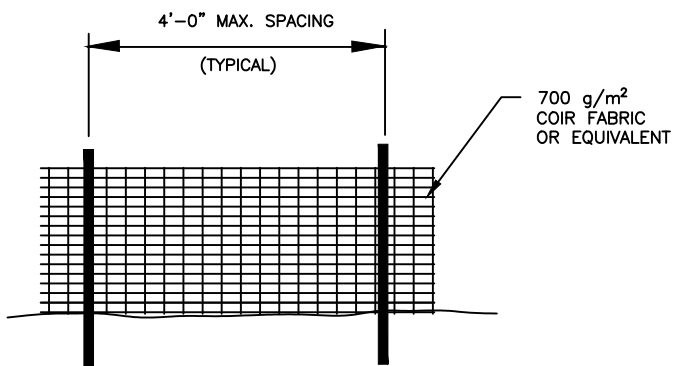

NOT TO SCALE



CITY OF CHARLOTTE
 LAND DEVELOPMENT STANDARDS
 INCLUDES CHARLOTTE ETJ

BAFFLE INSTALLATION

STD. NO.	REV.
30.19	22

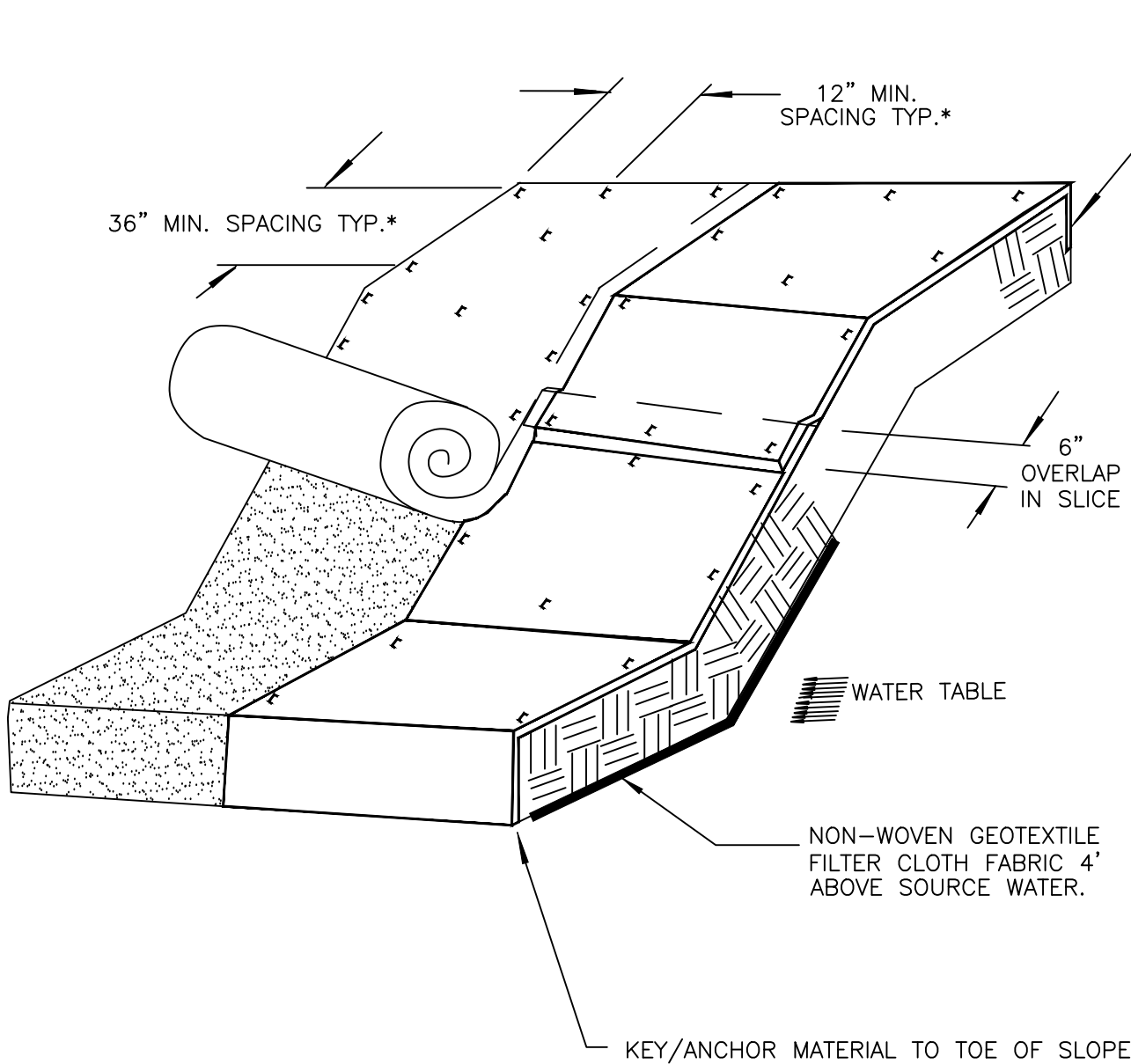

KEY/ANCHOR MATERIAL AT TOP OF SLOPE.

GENERAL NOTES:

1. LAY BLANKETS LOOSELY AND STAKE OR STAPLE TO MAINTAIN DIRECT CONTACT WITH THE SOIL. DO NOT STRETCH.
2. * DIMENSIONS SHOWN ARE MINIMUM, MANUFACTURED PRODUCTS MAY HAVE ADDITIONAL REQUIREMENTS THAT MUST BE MET.
3. SLOPE SURFACE SHALL BE FREE OF ROCKS, SOIL CLOUDS, STICKS, GRASS. MAT/BLANKETS SHALL HAVE GOOD SOIL CONTACT.
4. THE DETAIL SHOWN IS FOR SLOPE MATTING. FOR CHANNEL OR PIPE OUTFALL MATTING SPECIFICATIONS, PLEASE REFER TO NCESCPDM STANDARD #6.17 AND MANUFACTURER'S GUIDELINES.
5. ALL MATTING SHALL BE 100% BIODEGRADABLE WITH ORGANIC NETTING. PLASTIC OR NON-BIODEGRADABLE NETTING WILL NOT BE ALLOWED. PLEASE NOTE TURF REINFORCED MATTING (TRM) IS PERMITTED WHERE DESIGN CRITERIA WARRANTS ITS USE.

NOT TO SCALE



CITY OF CHARLOTTE
 LAND DEVELOPMENT STANDARDS
 INCLUDES CHARLOTTE ETJ

EMBANKMENT MATTING DETAIL

STD. NO.	REV.
30.20	22

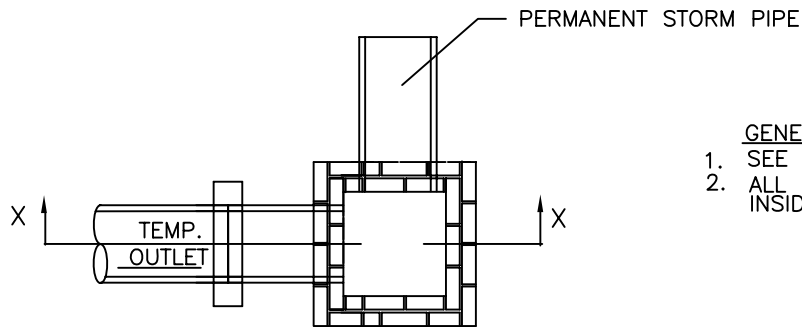

PLAN

GENERAL NOTES:

1. SEE APPROPRIATE STANDARD FOR CATCH BASIN, MANHOLE, JUNCTION BOX USED.
2. ALL PIPE IN STORM DRAIN STRUCTURES SHALL BE STRUCK EVEN WITH THE INSIDE WALL, GROUDED AND BRUSHED SMOOTH.

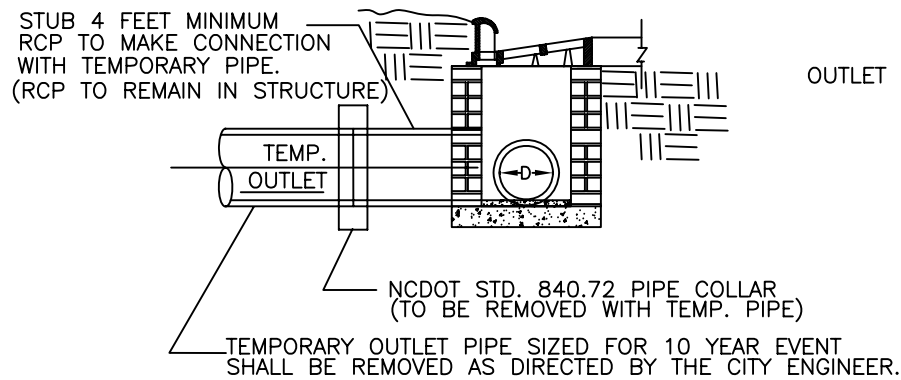

SECTION X-X
ACTIVE SYSTEM

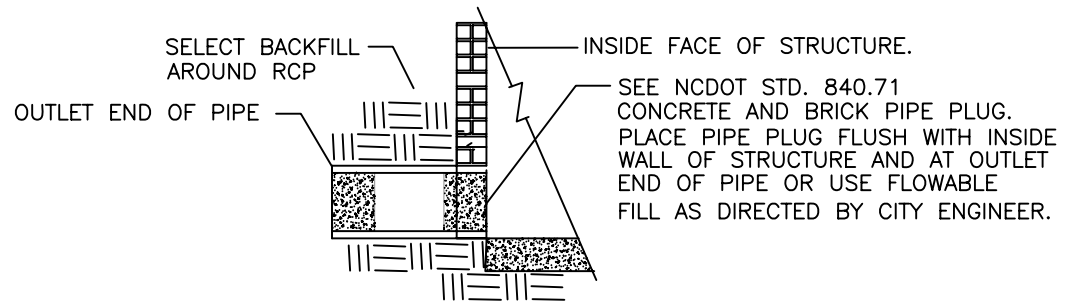

PIPE PLUG DETAIL
AFTER REMOVAL OF TEMPORARY PIPE

NOT TO SCALE



CITY OF CHARLOTTE
LAND DEVELOPMENT STANDARDS
INCLUDES CHARLOTTE ETJ

BRICK STORM STRUCTURE
WITH TEMPORARY PIPE

STD. NO.	REV.
30.21	

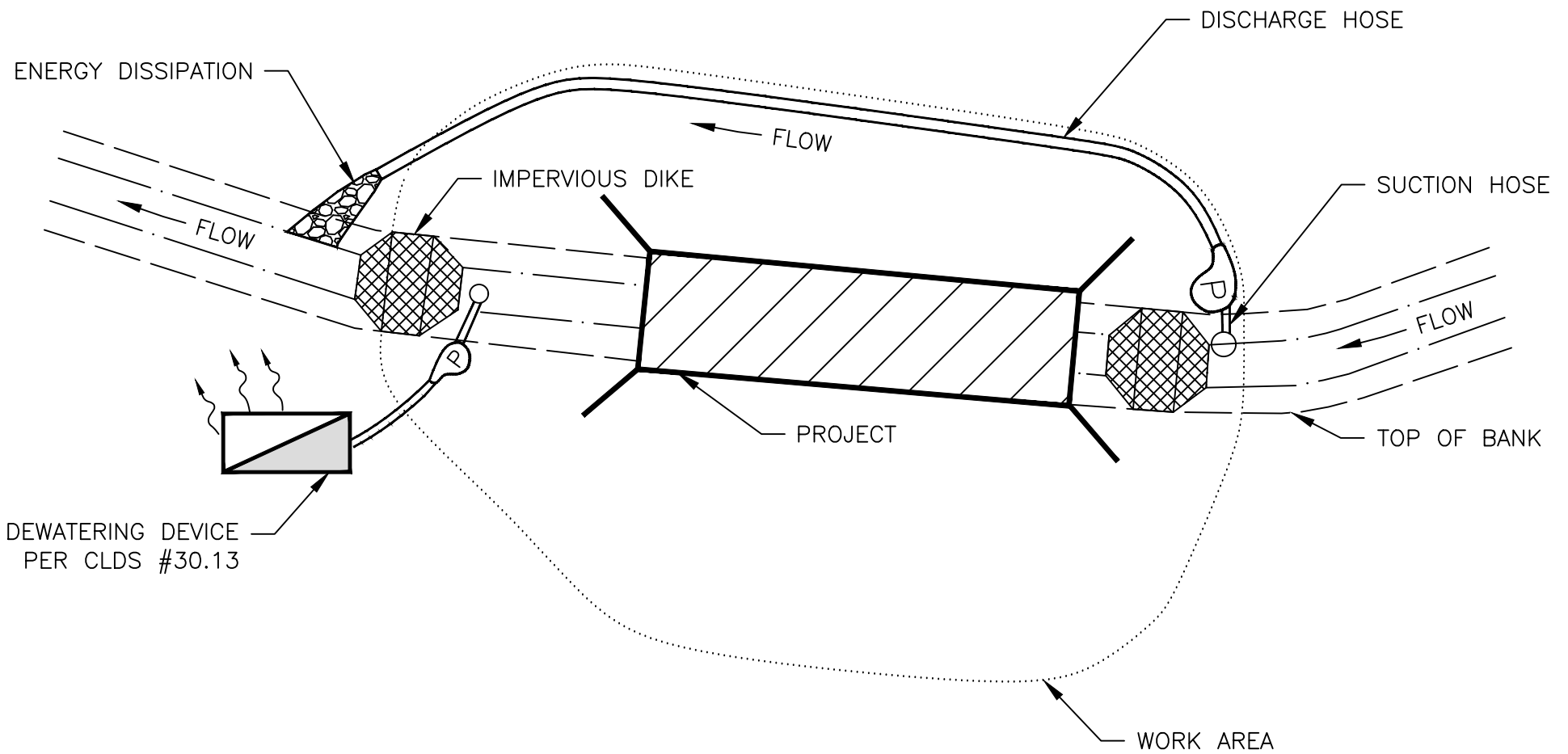

NOTE:
ANCHOR ALL PUMPS AND PIPES SECURELY

NOT TO SCALE



CITY OF CHARLOTTE
LAND DEVELOPMENT STANDARDS
INCLUDES CHARLOTTE ETJ

BYPASS PUMPING

STD. NO.	REV.
30.22A	24

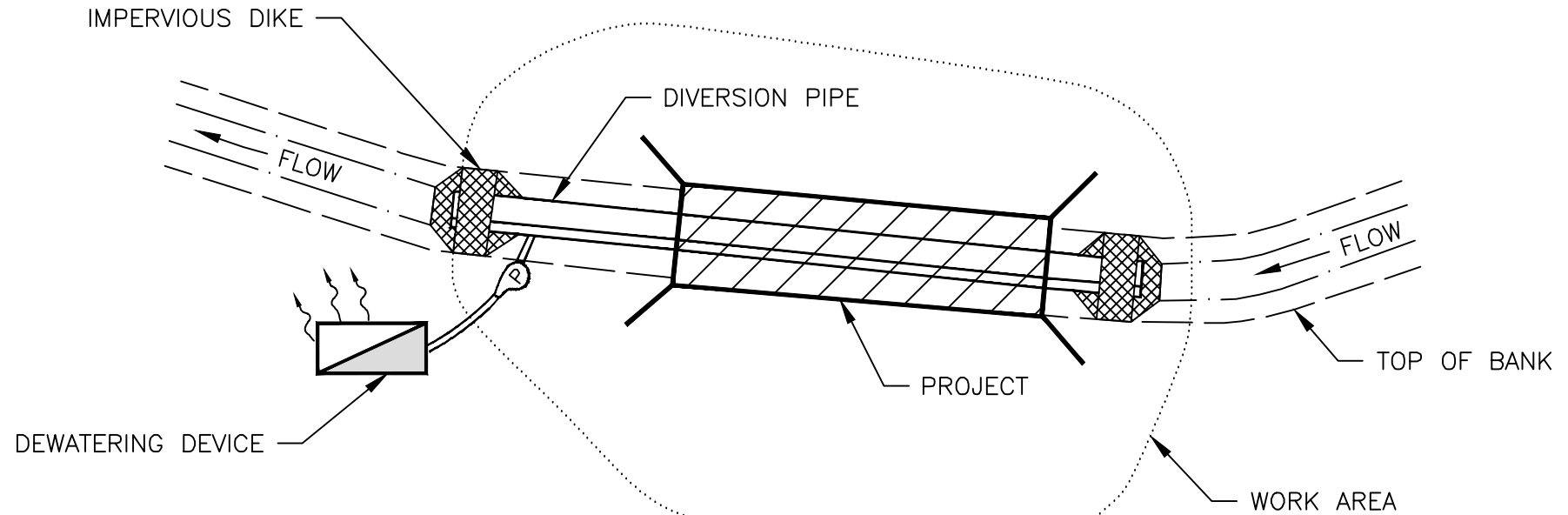

NOTE:
ANCHOR ALL PUMPS AND
PIPES SECURELY

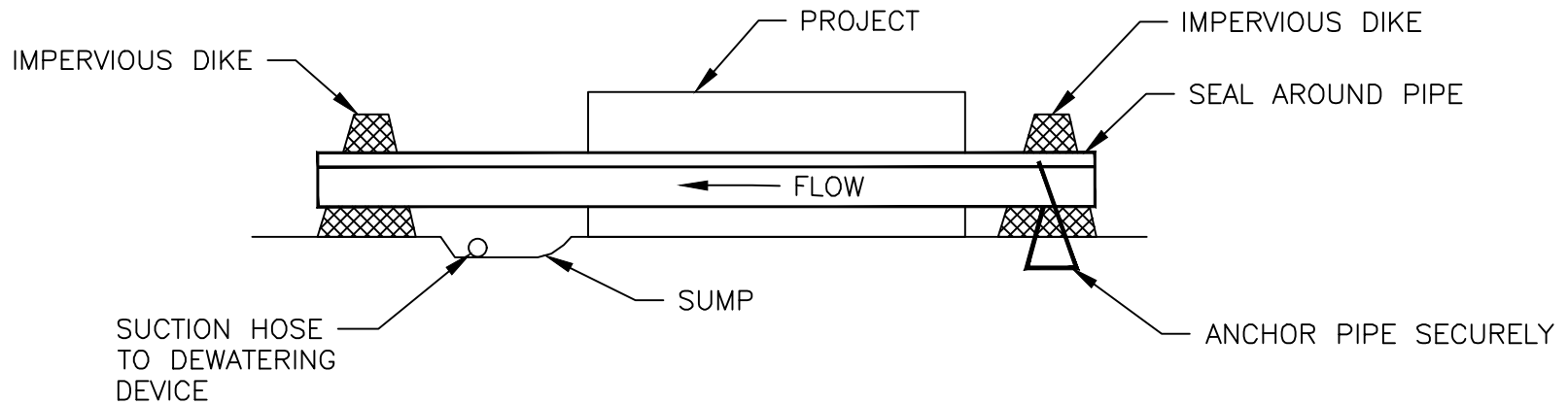

NOT TO SCALE



CITY OF CHARLOTTE
LAND DEVELOPMENT STANDARDS
INCLUDES CHARLOTTE ETJ

SUSPENDED BYPASS PIPE

STD. NO.	REV.
30.22B	15

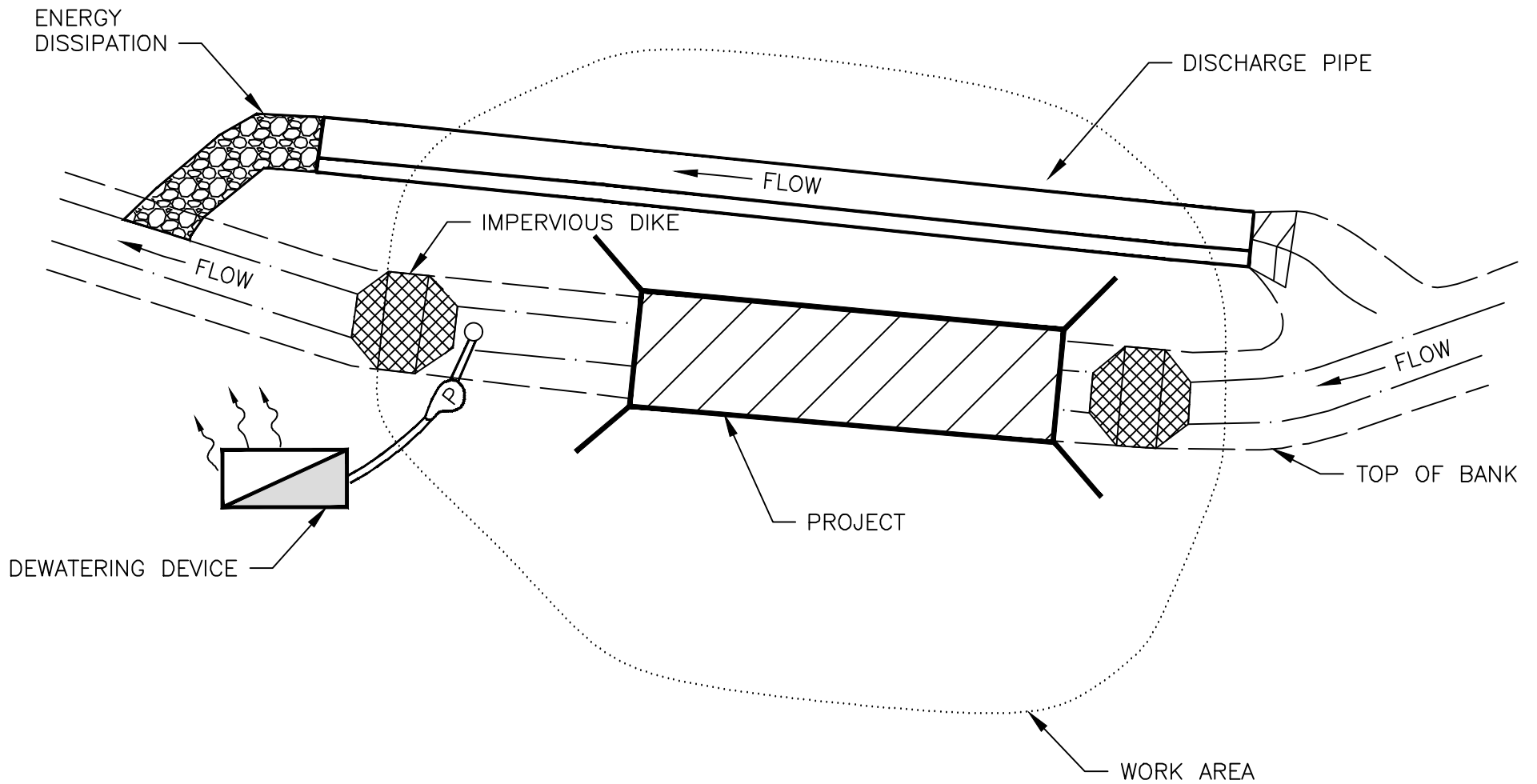

NOTE:
ANCHOR ALL PUMPS AND PIPES SECURELY

NOT TO SCALE



CITY OF CHARLOTTE
LAND DEVELOPMENT STANDARDS
INCLUDES CHARLOTTE ETJ

PIPED DIVERSION

STD. NO.	REV.
30.22C	15

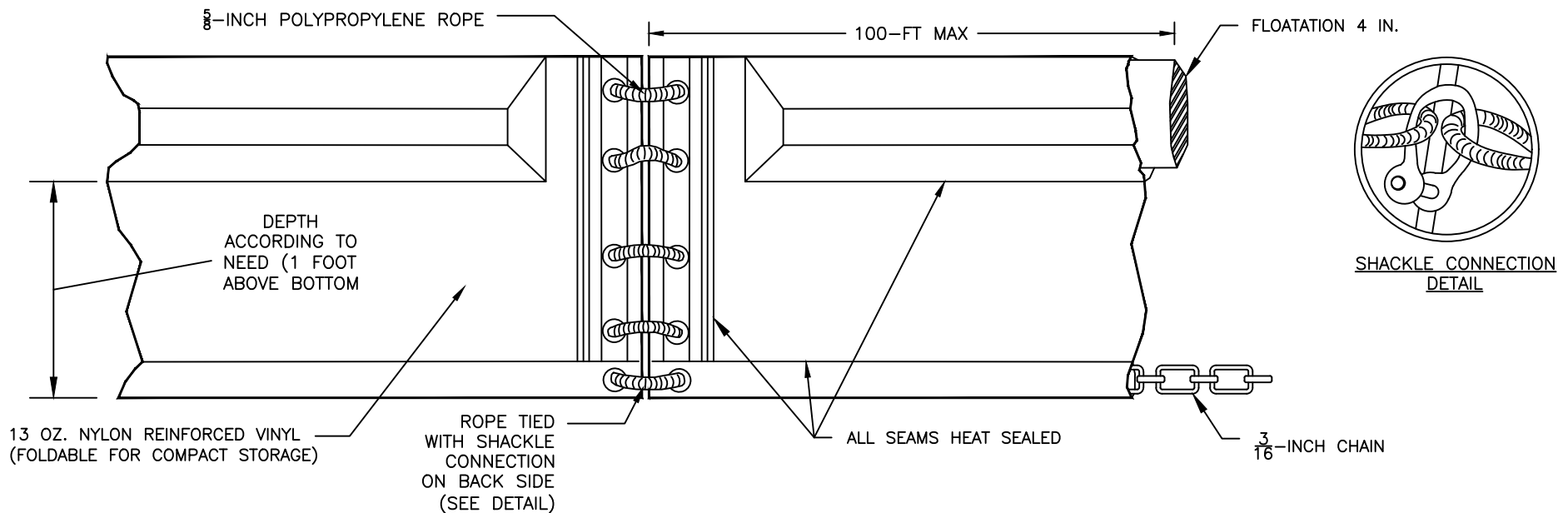

TURBIDITY CURTAIN (IN BASIN):

1. TURBIDITY CURTAINS MAY BE USED IN LIEU OF BAFFLES IN SEDIMENT OR SKIMMER BASINS WHERE THE TEMPORARY OR PERMANENT POOL ELEVATION WILL CONSISTENTLY BE ABOVE 3 FT (I.E. ABOVE TYPICAL INSTALLED BAFFLE HEIGHT).
2. A MINIMUM OF ONE TURBIDITY CURTAIN SHALL BE USED IN SKIMMER BASINS (30.02A) AND A MINIMUM OF ONE ROCK BAFFLE AND ONE TURBIDITY CURTAIN SHALL BE USED IN SEDIMENT BASINS (30.03A).
3. TYPE 1 TURBIDITY CURTAINS (FOR CALM WATERS) AT A MINIMUM SHALL BE USED, CONSTRUCTED OF MINIMUM SPECIFICATIONS OF 13 OZ. PVC FABRIC, 4 IN. FLOAT, AND A 3/16 IN. BOTTOM BALLAST CHAIN. THE MAXIMUM SPAN BETWEEN JOINTS IS 100 FT.
4. THE CURTAIN SHOULD EXTEND ACROSS THE ENTIRE WIDTH OF THE BASIN, BETWEEN THE SKIMMER/OUTLET ZONE AND INLETS AND BE ANCHORED TO THE BASIN EMBANKMENT A MINIMUM OF 6 INCHES ABOVE THE PRIMARY SPILLWAY ELEVATION. THE TURBIDITY CURTAIN SHALL EXTEND TO 1 FOOT ABOVE THE BOTTOM OF THE BASIN.
5. ACCUMULATED SEDIMENT SHALL BE REMOVED BEHIND THE TURBIDITY CURTAIN(S) TO RESTORE BASIN CAPACITY ONCE 50% CAPACITY IS REACHED.
6. WHEN THE CURTAIN IS NO LONGER REQUIRED, THE CURTAIN AND COMPONENTS SHALL BE REMOVED IN SUCH A MANNER AS TO MINIMIZE TURBIDITY. REMAINING SEDIMENT SHALL BE SUFFICIENTLY SETTLED BEFORE REMOVING THE CURTAIN. SEDIMENT MAY NEED TO BE REMOVED TO ACHIEVE THE PERMANENT PLANNED ELEVATION AND SPOILS PROPERLY DISPOSED OR STABILIZED.

TURBIDITY CURTAIN (IN POND/COVE):

1. TURBIDITY CURTAINS MAY BE USED IN PONDS OR COVES (WITH REQUISITE APPROVAL) WHERE UPSLOPE DISTURBANCES/CONSTRUCTION WILL OCCUR TO REDUCE SEDIMENT TRANSPORT TO A LIMITED AREA IN THE RECEIVING WATERCOURSE.
2. TYPE 1 TURBIDITY CURTAINS SHALL BE USED IN PROTECTED AREAS WHERE THERE IS NO CURRENT AND THE AREA IS SHELTERED FROM WIND AND WAVES, CONSTRUCTED OF MINIMUM SPECIFICATIONS OF 13 OZ. PVC FABRIC, 4 IN. FLOAT, AND A 3/16 IN. BOTTOM BALLAST CHAIN. THE MAXIMUM SPAN BETWEEN JOINTS IS 100 FT. SHOULD TYPE 2 OR TYPE 3 TURBIDITY CURTAINS BE NEEDED (WHERE THERE MAY BE SMALL TO CONSIDERATE CURRENT AND/OR WIND AND WAVE ACTION), ENGINEERED SPECIFICATIONS SHALL BE PROVIDED WITH THE PLAN SUBMISSION. TURBIDITY CURTAINS SHOULD NOT BE PLACED ACROSS THE MAIN FLOW OF A SIGNIFICANT BODY OF MOVING WATER.
3. THE TURBIDITY CURTAIN SHOULD BE ANCHORED TO THE SHORELINE ABOVE THE NORMAL HIGH WATER MARK, TOWED TO THE DESIRED LOCATION, AND ANCHORED (IF NEEDED) TO MAINTAIN THE DESIRED LOCATION WITHIN THE WATERCOURSE. THE TURBIDITY CURTAIN SHOULD EXTEND TO 1 FT ABOVE THE BOTTOM OF THE WATERCOURSE.
4. WHEN THE CURTAIN IS NO LONGER REQUIRED, THE CURTAIN, ANCHORS, AND COMPONENTS SHALL BE REMOVED AND IN SUCH A MANNER AS TO MINIMIZE TURBIDITY. REMAINING SEDIMENT SHALL BE SUFFICIENTLY SETTLED BEFORE REMOVING THE CURTAIN. SEDIMENT MAY NEED TO BE REMOVED TO ACHIEVE THE ORIGINAL DEPTH OF THE WATERCOURSE AND SPOILS PROPERLY DISPOSED OR STABILIZED.

NOT TO SCALE



CITY OF CHARLOTTE
 LAND DEVELOPMENT STANDARDS
 INCLUDES CHARLOTTE ETJ

TURBIDITY CURTAIN

STD. NO.	REV.
30.23	18

NOTES:

1. REMOVE WIRE AND NYLON TWINE FROM BALL AND CANOPY.
2. SOAK ROOT BALL AND PLANT PIT IMMEDIATELY AFTER INSTALLATION.
3. STAKING MAY BE REQUIRED FOR ALL CODE-REQUIRED TREES AND TREES PLANTED IN PUBLIC STREET RIGHT-OF-WAY.
4. REMOVE EXCESS SOIL FROM SITE AND DISPOSE OF IN A LEGAL MANNER.
5. RESEED UNMULCHED, DISTURBED AREAS.

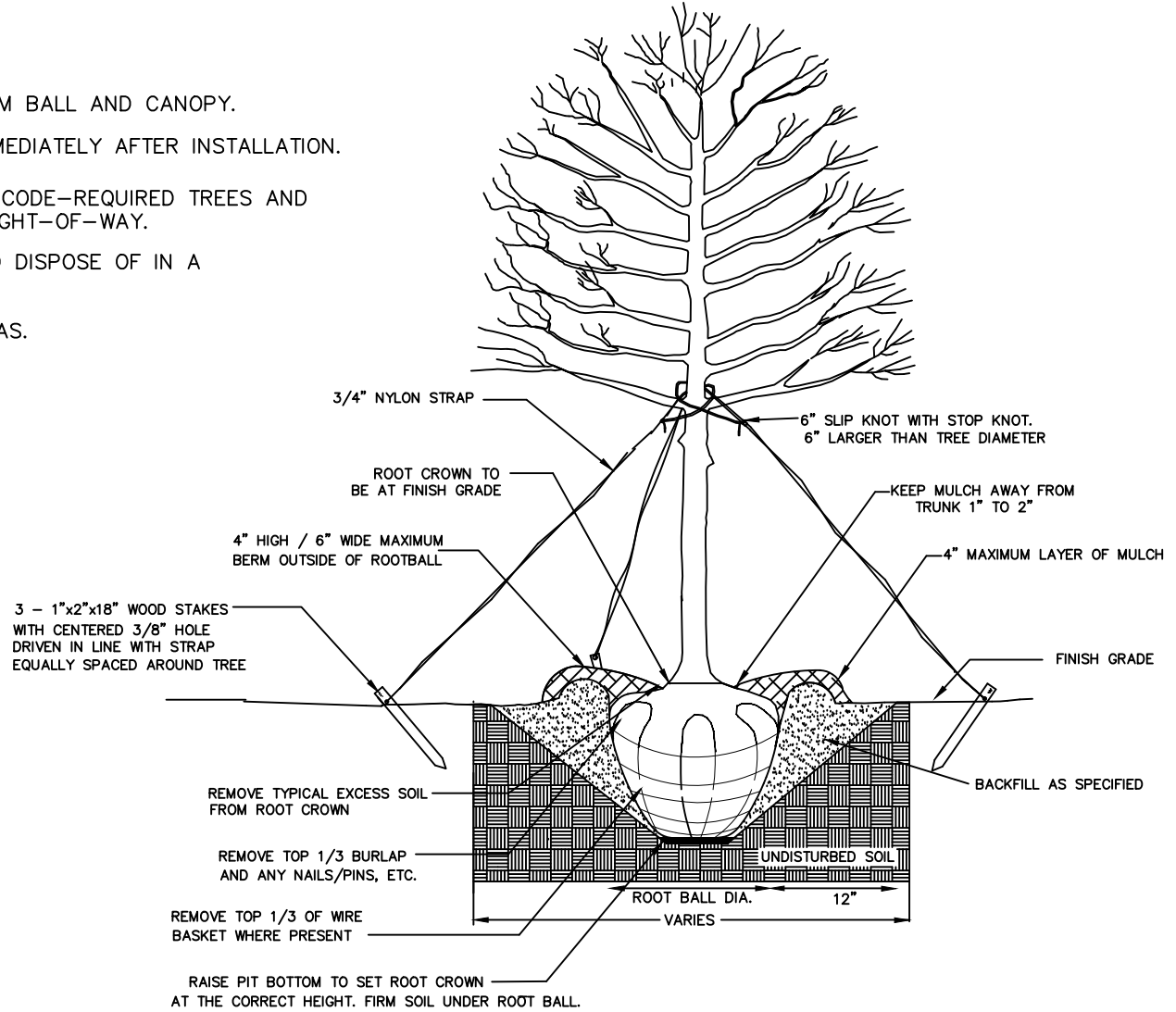

ALL TREES SHALL MEET AMERICAN STANDARD FOR NURSERY STOCK (ANSI Z60.1-2014 OR CURRENT EDITION)

FOR EXAMPLE:

CALIPER	HEIGHT (RANGE)	MAX. HEIGHT	MIN. ROOT BALL DIA.	MIN. ROOT BALL DEPTH
2"	12-14'	16'	24"	16"
3"	14-16'	18'	32"	21"

NOT TO SCALE



CITY OF CHARLOTTE
LAND DEVELOPMENT STANDARDS
INCLUDES CHARLOTTE ETJ

TREE PLANTING
(FOR SINGLE AND MULTI-STEM TREES)

STD. NO.	REV.
40.01	23

SEE APPROVED TREE PRESERVATION PLAN FOR REQUIRED RADIUS OF TREE BARRIER

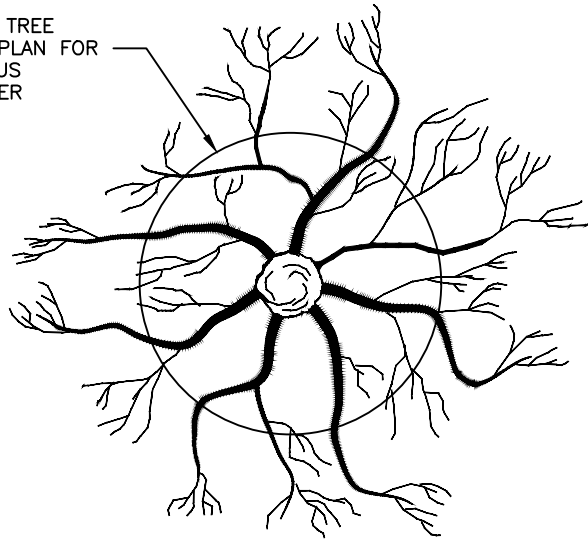

PLAN VIEW OF ROOT ZONE

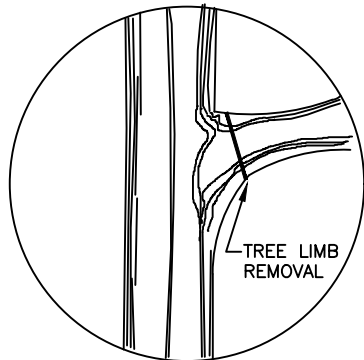

FOR PRUNING SEE INTERNATIONAL SOCIETY OF ARBORICULTURE SPECS.

DEAD TREES AND SCRUB OR UNDERGROWTH SHALL BE CUT FLUSH WITH ADJACENT GRADE. NO GRUBBING ALLOWED UNDER DRIP LINE.

2"x4" STANDARDS + 1"x4" RAILS OR ORANGE SAFETY FENCING MAY BE USED.

NOTES:

1. REMOVE ALL BARRIERS UPON COMPLETION OF PROJECT.
2. LANDSCAPING PLANS SHALL SHOW THE LOCATIONS OF ALL PROTECTION FENCES.
3. REFER TO CITY OF CHARLOTTE LANDSCAPE CONSTRUCTION STANDARDS SECTION 01000 FOR GENERAL SPECIFICATION REGARDING TREE PROTECTION.
4. INSTALL TREE PROTECTION SIGNAGE ON ALL FENCE BOUNDARIES PER CHARLOTTE TREE MANUAL (CTM) AND LANDSCAPE CONSTRUCTION STANDARDS. SIGN TEMPLATE PROVIDED IN CTM.
5. REFER TO CTM FOR CRITICAL ROOT ZONE PROTECTION STANDARDS.

ONE FOOT FOR EACH INCH OF TRUNK DIAMETER OR 1/2 HEIGHT OF TREE WHICHEVER IS GREATER

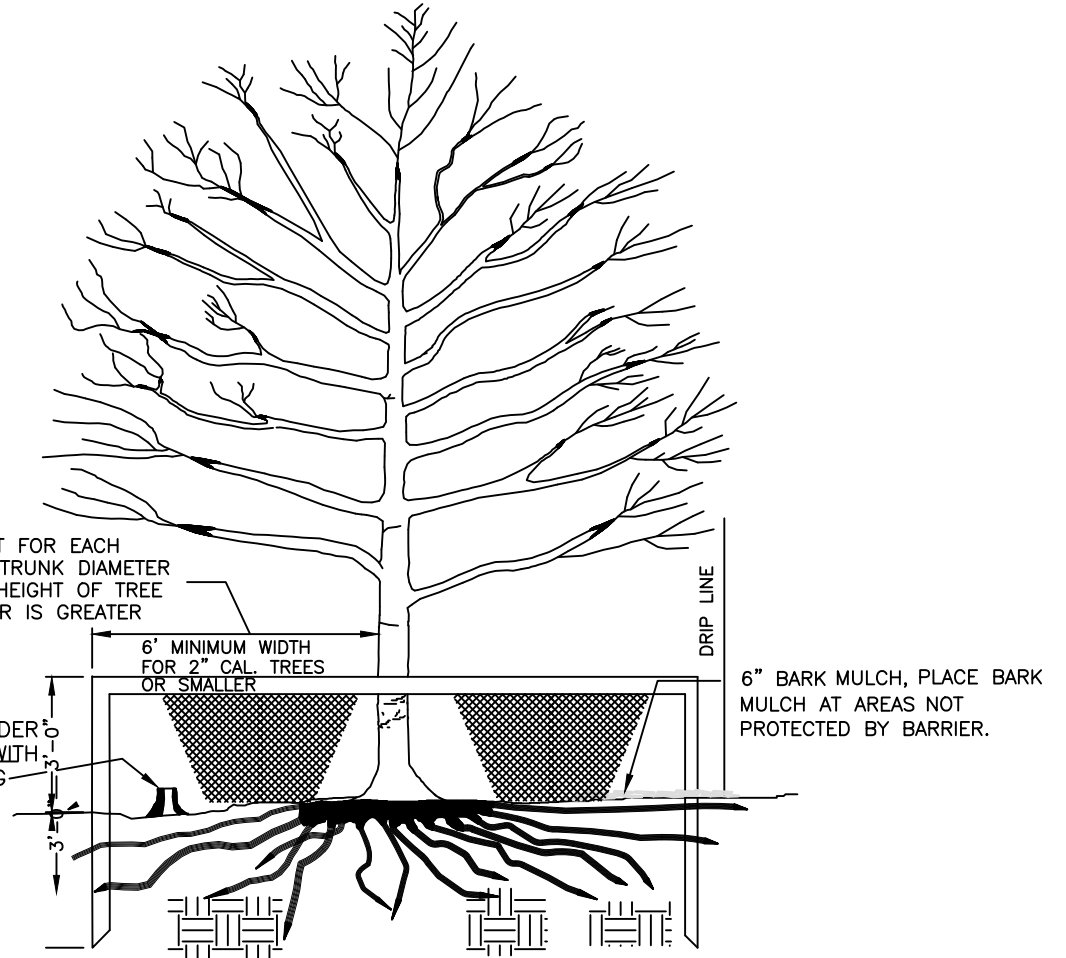

6" BARK MULCH, PLACE BARK MULCH AT AREAS NOT PROTECTED BY BARRIER.



CITY OF CHARLOTTE
LAND DEVELOPMENT STANDARDS
INCLUDES CHARLOTTE ETJ

TREE PROTECTION DETAIL

STD. NO.	REV.
40.02	23

REINFORCING STEEL TO EXTEND 4' BEYOND END OF SUSPENDED SLAB / TREE PIT

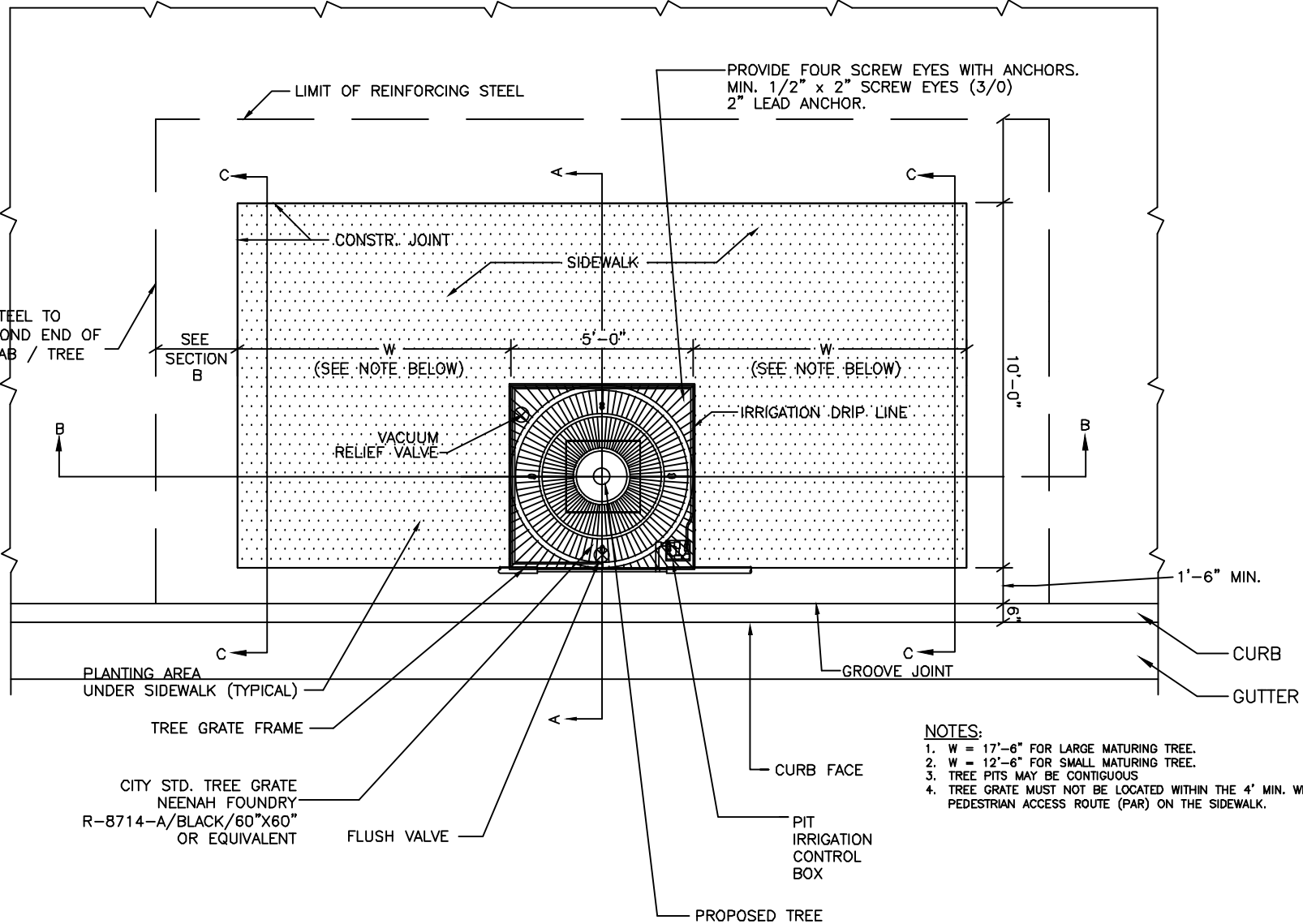

- NOTES:**
1. W = 17'-6" FOR LARGE MATURING TREE.
 2. W = 12'-6" FOR SMALL MATURING TREE.
 3. TREE PITS MAY BE CONTIGUOUS
 4. TREE GRATE MUST NOT BE LOCATED WITHIN THE 4' MIN. WIDTH PEDESTRIAN ACCESS ROUTE (PAR) ON THE SIDEWALK.



CITY OF CHARLOTTE
LAND DEVELOPMENT STANDARDS
 INCLUDES CHARLOTTE ETJ

LARGE AND SMALL MATURING TREE PIT WITH GRATE IN SIDEWALK (PLAN)

STD. NO.	REV.
40.03	13

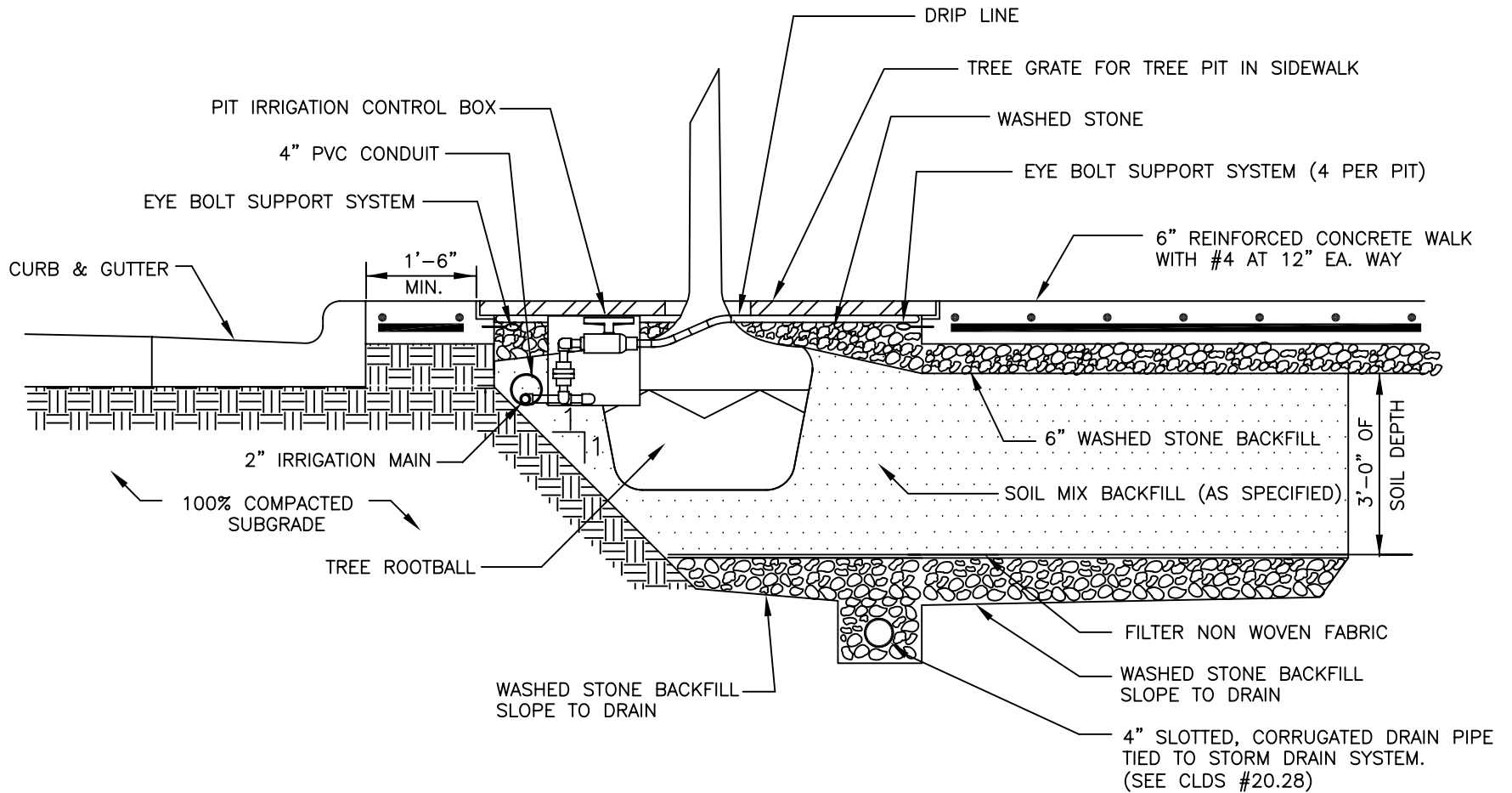

SECTION A



CITY OF CHARLOTTE
 LAND DEVELOPMENT STANDARDS
 INCLUDES CHARLOTTE ETJ

LARGE AND SMALL MATURING TREE PIT
 WITH GRATE IN SIDEWALK (SECTION)

STD. NO.	REV.
40.03A	3

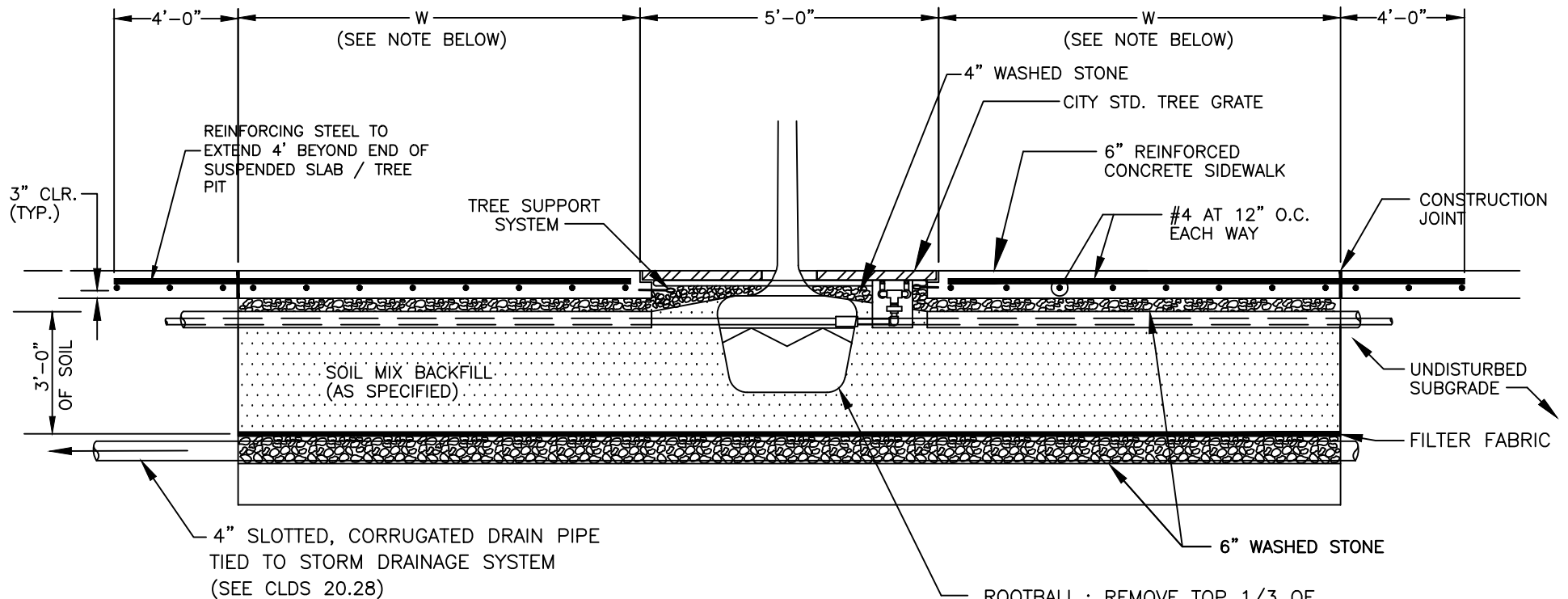

NOTE:

W = 17'-6" FOR LARGE MATURING TREE.
 W = 12'-6" FOR SMALL MATURING TREE.
 TREE PITS MAY BE CONTIGUOUS

ROOTBALL : REMOVE TOP 1/3 OF BURLAP FROM B&B TREES;
 REMOVE TOP 2/3 OF WIRE BASKET, WHERE PRESENT.

SECTION B



CITY OF CHARLOTTE
 LAND DEVELOPMENT STANDARDS
 INCLUDES CHARLOTTE ETJ

LARGE AND SMALL MATURING TREE PIT
 WITH GRATE IN SIDEWALK (SECTION)

STD. NO.	REV.
40.03B	23

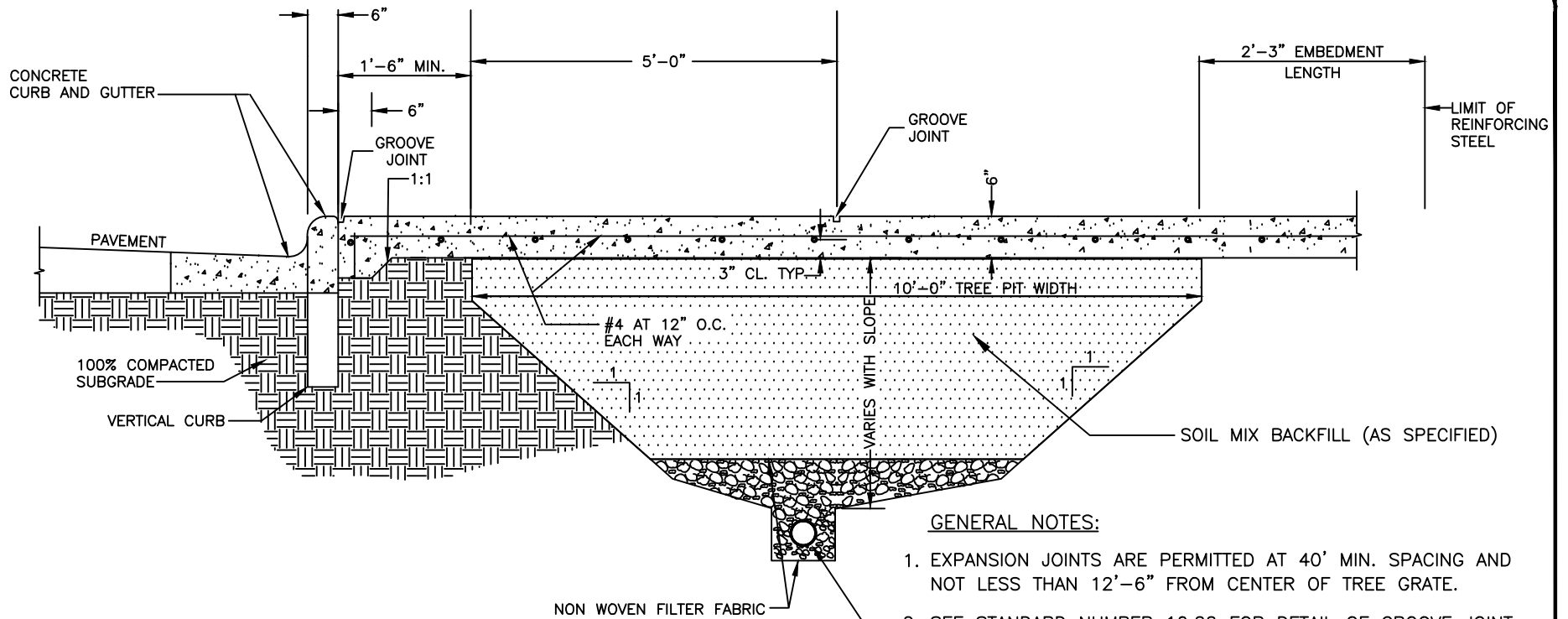

NOTE

A DRAINAGE SYSTEM IS REQUIRED AS SHOWN FOR ALL IRRIGATED PLANTING AREAS LOCATED ADJACENT TO STREET.

GENERAL NOTES:

1. EXPANSION JOINTS ARE PERMITTED AT 40' MIN. SPACING AND NOT LESS THAN 12'-6" FROM CENTER OF TREE GRATE.
2. SEE STANDARD NUMBER 10.22 FOR DETAIL OF GROOVE JOINT.
3. CONCRETE SHALL BE 3600 PSI. IN 28 DAYS.
4. ALL REINFORCING STEEL SHALL BE GRADE 60.
5. USE REINFORCED STEEL BAR SUPPORTS IN COMPLIANCE WITH N.C.D.O.T. STANDARD SPECIFICATION 970-4.

SECTION C



**CITY OF CHARLOTTE
LAND DEVELOPMENT STANDARDS
INCLUDES CHARLOTTE ETJ**

**LARGE AND SMALL TREE PIT WITH
GRATE IN SIDEWALK (SECTION)**

STD. NO.	REV.
40.03C	12

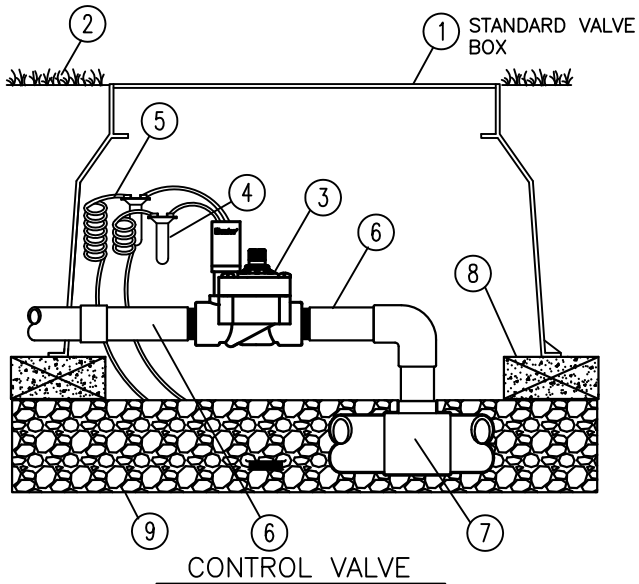

- ② FINISH GRADE
- ③ CONTROL VALVE WITH FLOW CONTROL
- ④ WATERPROOF CONNECTORS (2)
- ⑤ 18-24" COILED WIRE
- ⑥ SCH 80 T.O.E. NIPPLE
- ⑦ MAIN LINE PIPE & FITTINGS
- ⑧ BRICK SUPPORTS (4)
- ⑨ 3/4" MINUS WASHED GRAVEL, MIN. 3" DEPTH
- ⑩ PRESSURE REGULATOR
- ⑪ FILTER

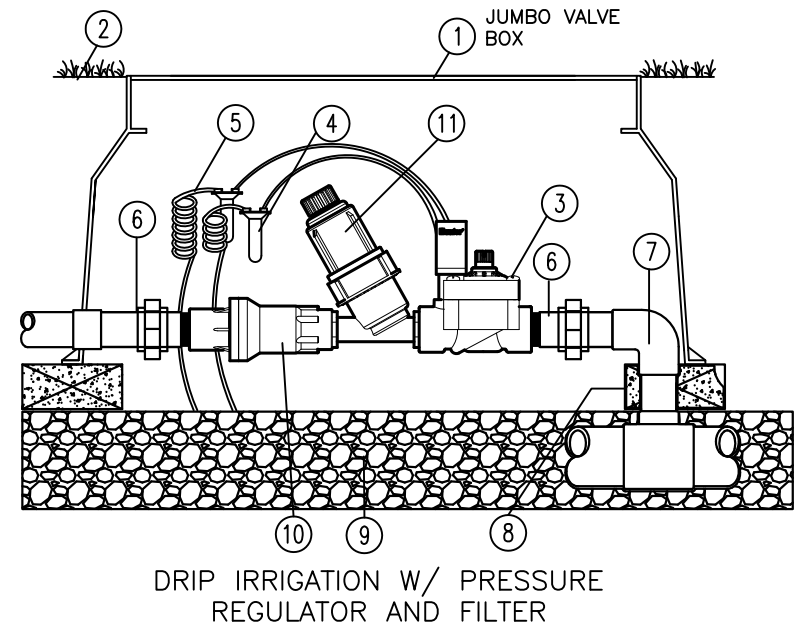

DRIP IRRIGATION W/ PRESSURE REGULATOR AND FILTER



CITY OF CHARLOTTE
 LAND DEVELOPMENT STANDARDS
 INCLUDES CHARLOTTE ETJ

TYPICAL VALVE AND VALVE BOX INSTALLATION

STD. NO.	REV.
40.04	9

NOTES:

1. SCARIFY ROOT MASS OF CONTAINERIZED PLANT MATERIAL.
2. INSTALL CONTAINERIZED PLANTS AT FINISHED GRADE
3. TAMP PLANTING MIX FIRMLY AS PIT IS FILLED AROUND EACH PLANT BALL.
4. OMIT COLLAR AROUND EACH SHRUB WHEN IRRIGATION SYSTEM IS PRESENT.
5. SOAK EACH PLANT BALL AND PIT IMMEDIATELY AFTER INSTALLATION.

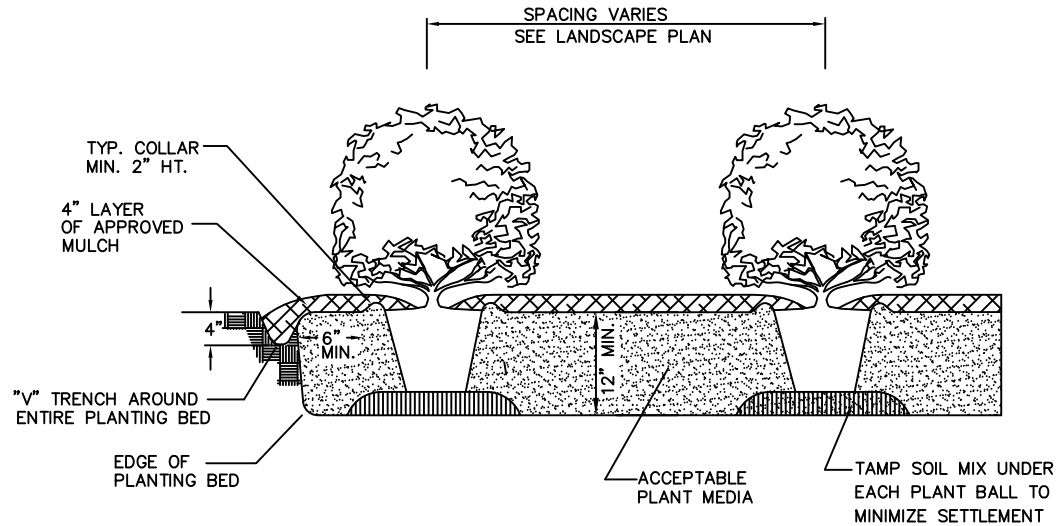

TYPICAL PLANTING BED DETAIL

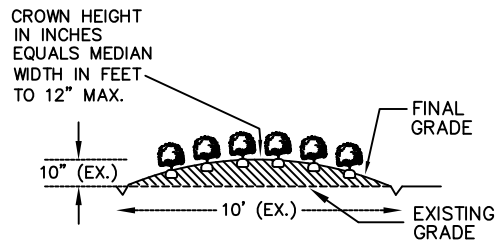

TYPICAL BED CROWNING

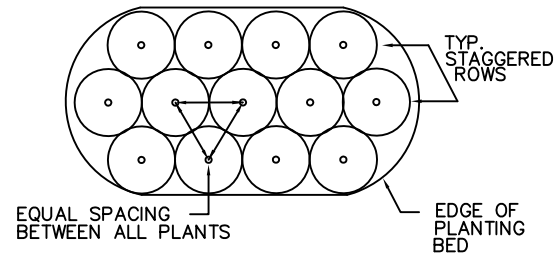

TYPICAL PLANTING BED PLAN



NOTES:

1. SCARIFY ROOT MASS OF CONTAINERIZED PLANT MATERIAL.
2. INSTALL CONTAINERIZED PLANTS AT FINISHED GRADE
3. TAMP PLANTING MIX FIRMLY AS PIT IS FILLED AROUND EACH PLANT BALL.
4. OMIT COLLAR AROUND EACH SHRUB WHEN IRRIGATION SYSTEM IS PRESENT.
5. SOAK EACH PLANT BALL AND PIT IMMEDIATELY AFTER INSTALLATION.

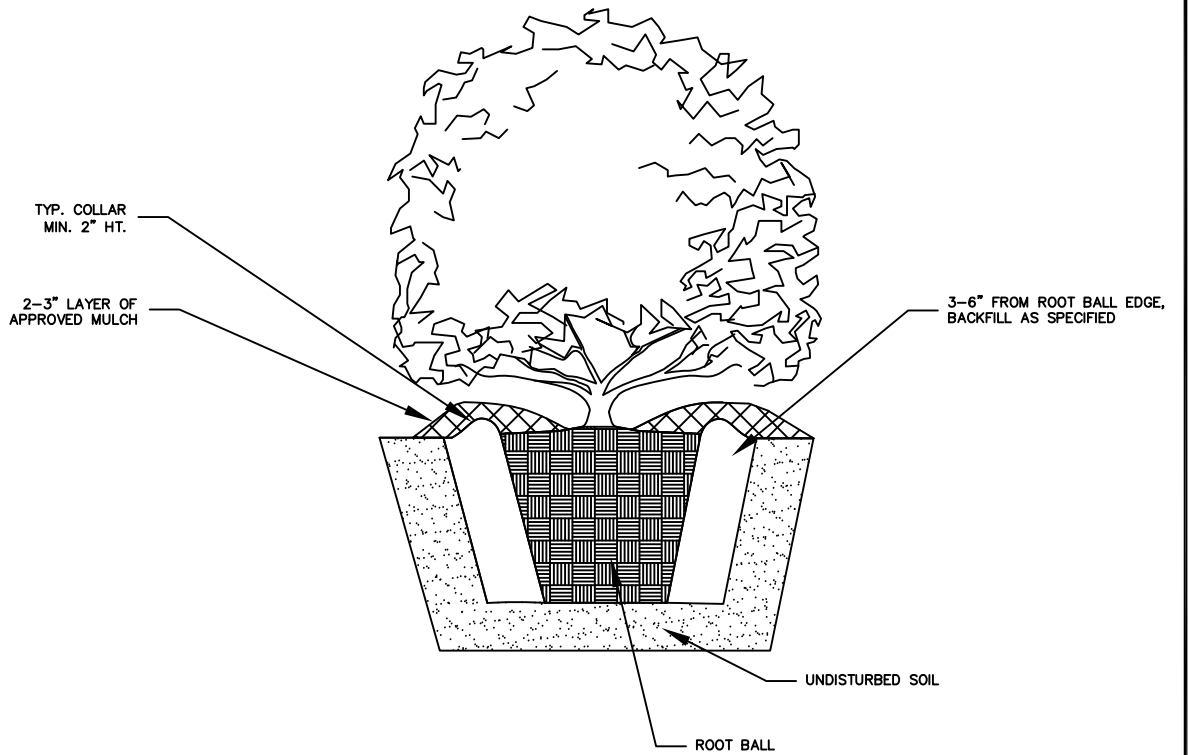

CITY OF CHARLOTTE
 LAND DEVELOPMENT STANDARDS
 INCLUDES CHARLOTTE ETJ

INDIVIDUAL
 SMALL SHRUB/TREE PLANTING

STD. NO.	REV.
40.05B	9

NOTES:

1. FOR NEW PLANTING AREAS, REMOVE ALL PAVEMENT, GRAVEL, SUB-BASE AND CONSTRUCTION DEBRIS BEFORE PREPARING SOIL AND PLANTING TREES
2. PLANTING STRIPS APPROVED AND/OR REQUIRED BY THE CITY WITH WIDTHS LESS THAN 8' MAY REQUIRE IRRIGATION AND DRAINAGE.
3. REMOVE OR DE-COMPACT EXISTING REMAINING SOIL. AMEND OR PROVIDE NEW SOIL TO A DEPTH OF 18". USE APPROVED PLANTING MIX WHEN AMENDING. SEE CHARLOTTE TREE MANUAL (CTM) AND LANDSCAPE CONSTRUCTION STANDARDS. SITES WITH EXTREMELY POOR EXISTING SOIL MAY REQUIRE AMENDING BEYOND 18" DEPTH.
4. IRRIGATION AND SUBDRAIN ARE NOT APPROVED FOR USE ON NCDOT-MAINTAINED STREETS.

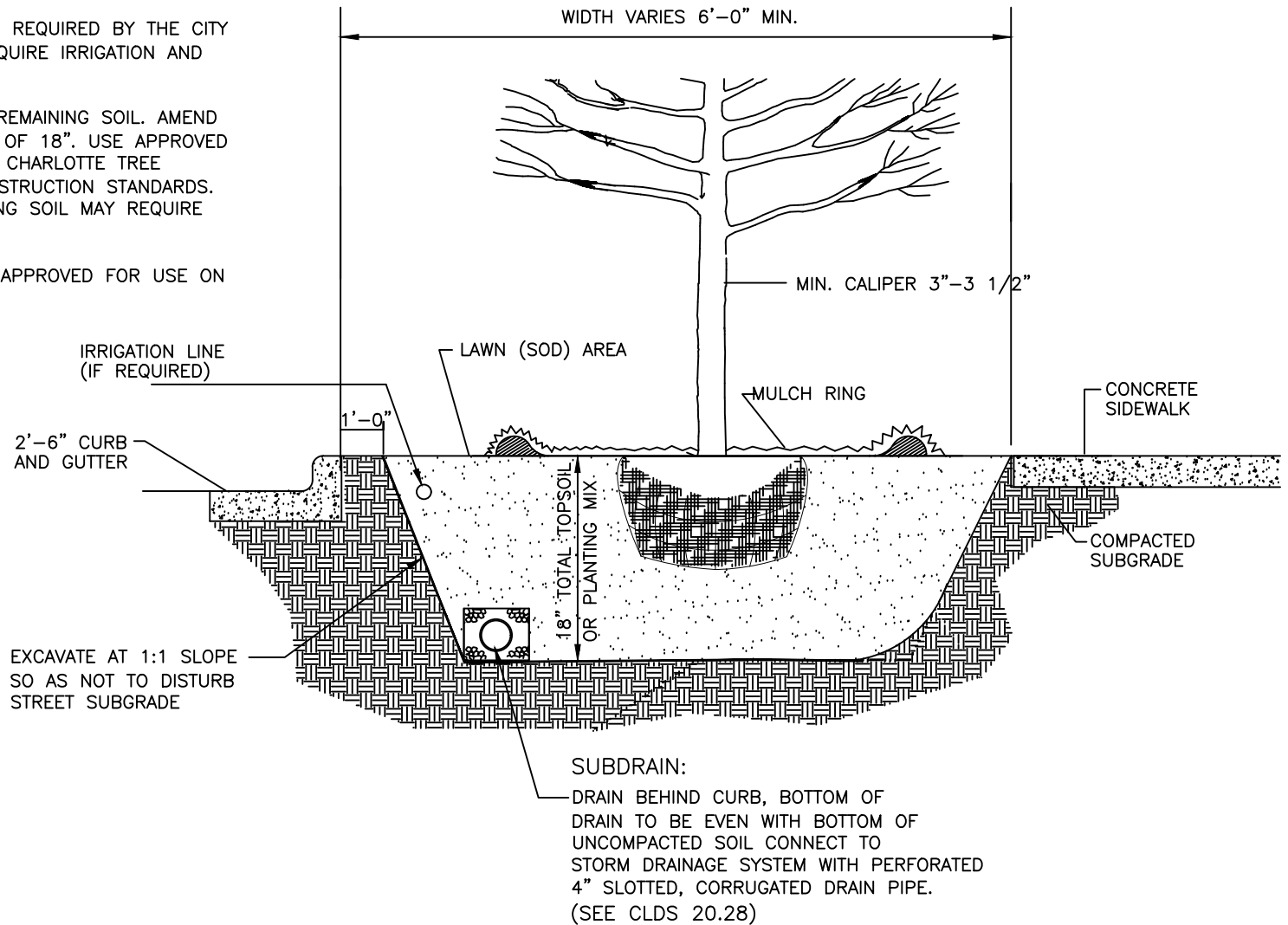

**CITY OF CHARLOTTE
LAND DEVELOPMENT STANDARDS**

**PLANTING STRIPS LESS THAN 8' IN WIDTH
(WITH IRRIGATION AND DRAINAGE)**

STD. NO.	REV.
40.06	23

NOTES:

1. FOR NEW PLANTING AREAS, REMOVE ALL PAVEMENT, GRAVEL, SUB-BASE AND CONSTRUCTION DEBRIS BEFORE PREPARING SOIL AND PLANTING TREES.
2. REMOVE AND/OR AMEND EXISTING SOIL TO A DEPTH OF 18". SCARIFY, TILL, OR OTHERWISE LOOSEN REMAINING SOIL TO A DEPTH OF 18". ADD NEW PLANTING MIX AS NEEDED AND SPECIFIED BY THE CHARLOTTE TREE MANUAL (CTM) AND LANDSCAPE CONSTRUCTION STANDARDS.
3. SUBSURFACE DRAINAGE SHALL BE INSTALLED IN ALL MEDIANS AND TIED INTO EXISTING STORM DRAIN SYSTEM. A 4 INCH PERFORATED CORRUGATED PVC DRAIN OR HDPE PER AASHTO M252, TYPE CP (SINGLE-WALL, CORRUGATED) SHALL BE INSTALLED IN EACH MEDIAN AT THE BOTTOM OF THE EXCAVATED AREA. DRAIN SHALL BE COVERED WITH A MINIMUM 6 INCHES OF #57 WASHED STONE, THEN WRAPPED WITH A SPECIFIED NON-WOVEN GEOTEXTILE FABRIC. SPECIAL CARE SHALL BE EXERCISED WHEN FILLING MEDIANS WITH SOIL SO NOT TO CRUSH OR DAMAGE THE DRAINAGE SYSTEM.

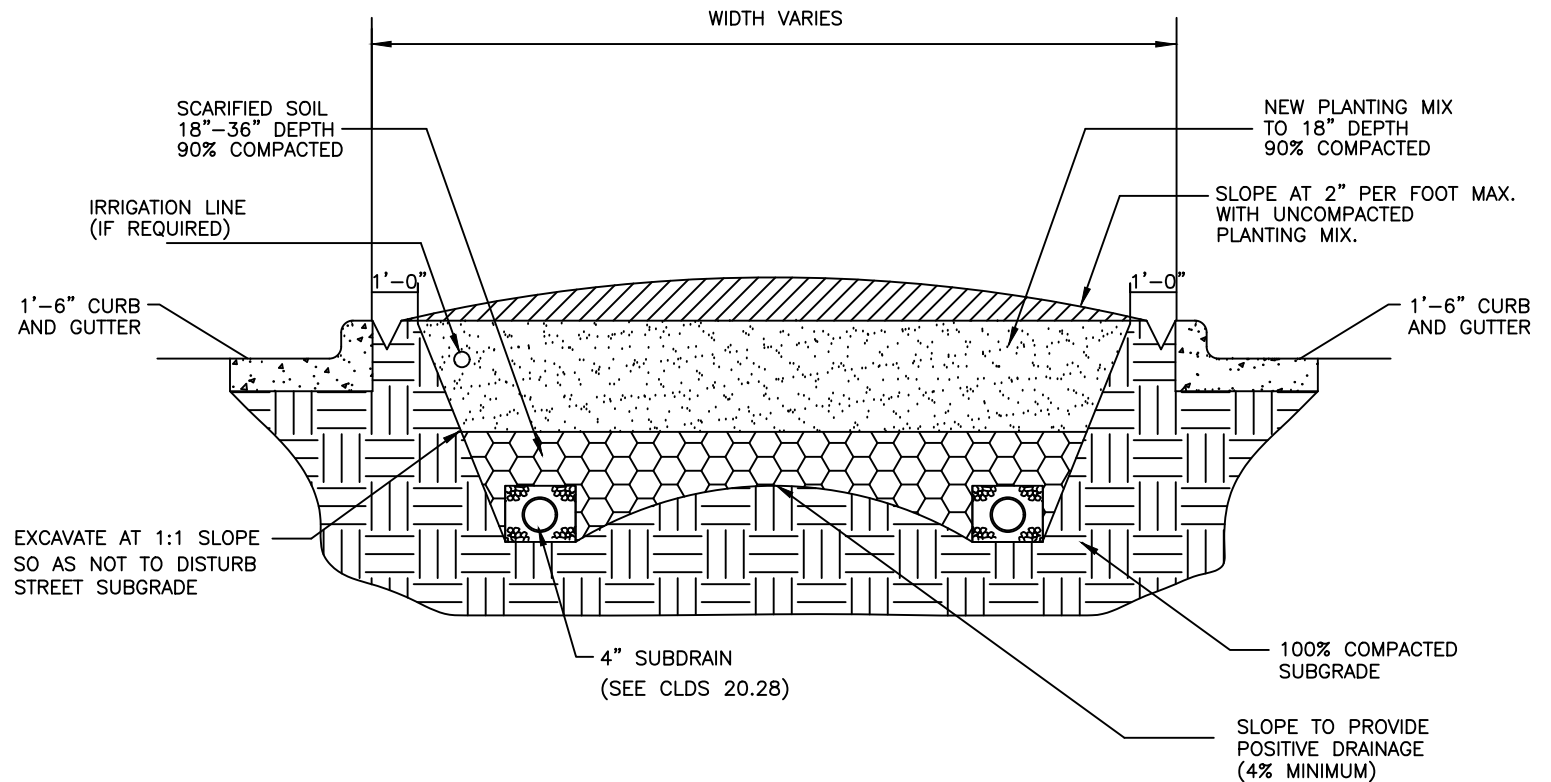

CITY OF CHARLOTTE
LAND DEVELOPMENT STANDARDS
INCLUDES CHARLOTTE ETJ

MEDIAN GREATER THAN 120 INCHES
EXCAVATION, DRAINAGE AND BACKFILL

STD. NO.	REV.
40.08A	23

NOTES:

1. FOR NEW PLANTING AREAS, REMOVE ALL PAVEMENT, GRAVEL, SUB-BASE AND CONSTRUCTION DEBRIS BEFORE PREPARING SOIL AND PLANTING TREES.
2. REMOVE AND/OR AMEND EXISTING SOIL TO A DEPTH OF 18". SCARIFY, TILL, OR OTHERWISE LOOSEN REMAINING SOIL TO A DEPTH OF 18". ADD NEW PLANTING MIX AS NEEDED AND SPECIFIED BY THE CHARLOTTE TREE MANUAL (CTM) AND LANDSCAPE CONSTRUCTION STANDARDS.
3. SUBSURFACE DRAINAGE SHALL BE INSTALLED IN ALL MEDIANS AND TIED INTO EXISTING STORM DRAIN SYSTEM. A 4 INCH PERFORATED CORRUGATED PVC DRAIN OR HDPE PER AASHTO M252, TYPE CP (SINGLE-WALL, CORRUGATED) SHALL BE INSTALLED IN EACH MEDIAN AT THE BOTTOM OF THE EXCAVATED AREA. DRAIN SHALL BE COVERED WITH A MINIMUM 6 INCHES OF #57 WASHED STONE, THEN WRAPPED WITH A SPECIFIED NON-WOVEN GEOTEXTILE FABRIC. SPECIAL CARE SHALL BE EXERCISED WHEN FILLING MEDIANS WITH SOIL SO NOT TO CRUSH OR DAMAGE THE DRAINAGE SYSTEM.

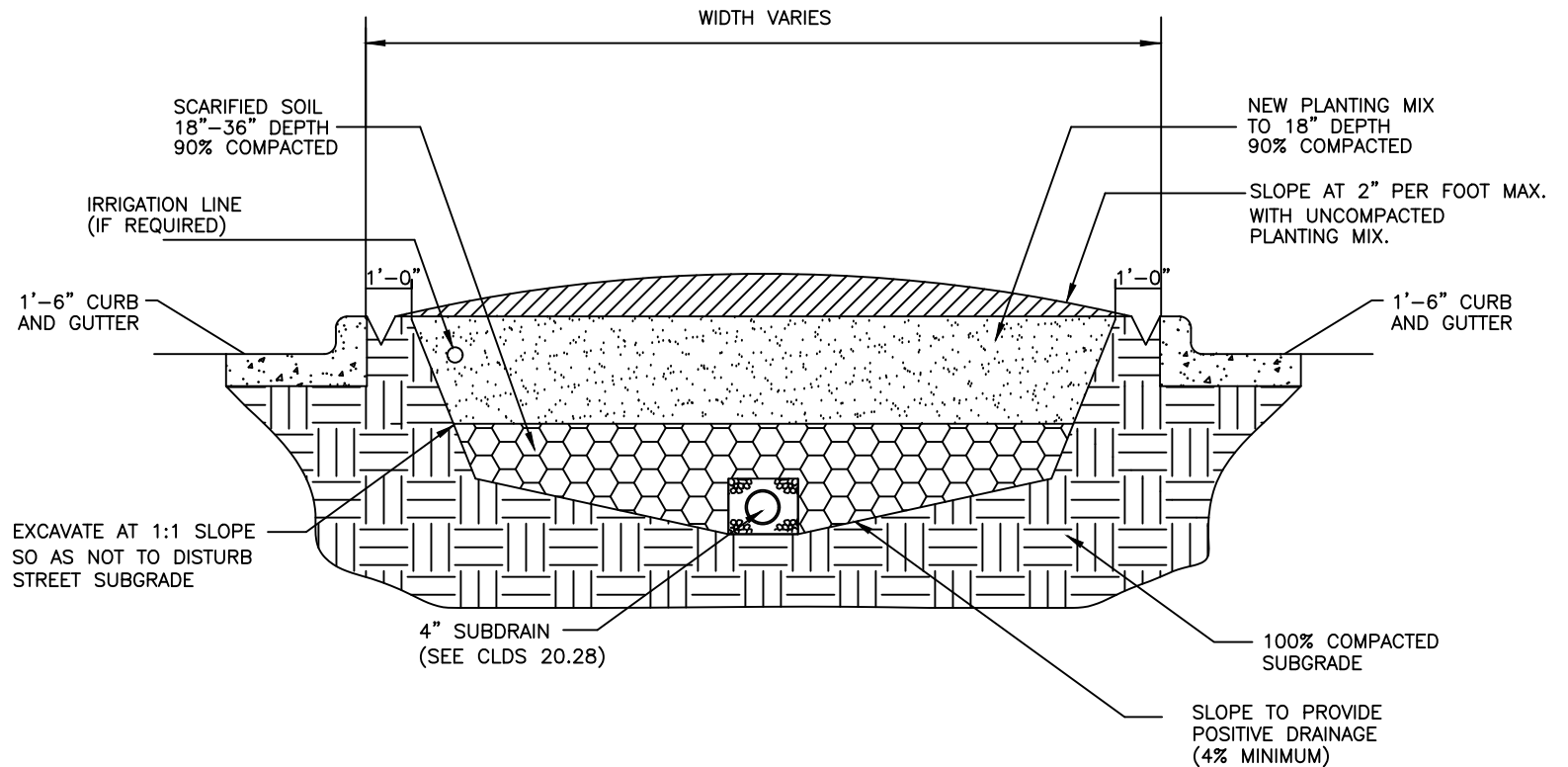

CITY OF CHARLOTTE
 LAND DEVELOPMENT STANDARDS
 INCLUDES CHARLOTTE ETJ

73 TO 120 INCH MEDIAN
 EXCAVATION, DRAINAGE AND BACKFILL

STD. NO.	REV.
40.08B	23

NOTES:

1. FOR NEW PLANTING AREAS, REMOVE ALL PAVEMENT, GRAVEL, SUB-BASE AND CONSTRUCTION DEBRIS BEFORE PREPARING SOIL AND PLANTING TREES.
2. REMOVE AND/OR AMEND EXISTING SOIL TO A DEPTH OF 18". SCARIFY, TILL, OR OTHERWISE LOOSEN REMAINING SOIL TO A DEPTH OF 18". ADD NEW PLANTING MIX AS NEEDED AND SPECIFIED BY THE CHARLOTTE TREE MANUAL (CTM) AND LANDSCAPE CONSTRUCTION STANDARDS..
3. SUBSURFACE DRAINAGE SHALL BE INSTALLED IN ALL MEDIANS AND TIED INTO EXISTING STORM DRAIN SYSTEM. A 4 INCH PERFORATED CORRUGATED PVC DRAIN OR HDPE PER AASHTO M252, TYPE CP (SINGLE-WALL, CORRUGATED) SHALL BE INSTALLED IN EACH MEDIAN AT THE BOTTOM OF THE EXCAVATED AREA. DRAIN SHALL BE COVERED WITH A MINIMUM 6 INCHES OF #57 WASHED STONE, THEN WRAPPED WITH A SPECIFIED NON-WOVEN GEOTEXTILE FABRIC. SPECIAL CARE SHALL BE EXERCISED WHEN FILLING MEDIANS WITH SOIL SO NOT TO CRUSH OR DAMAGE THE DRAINAGE SYSTEM.

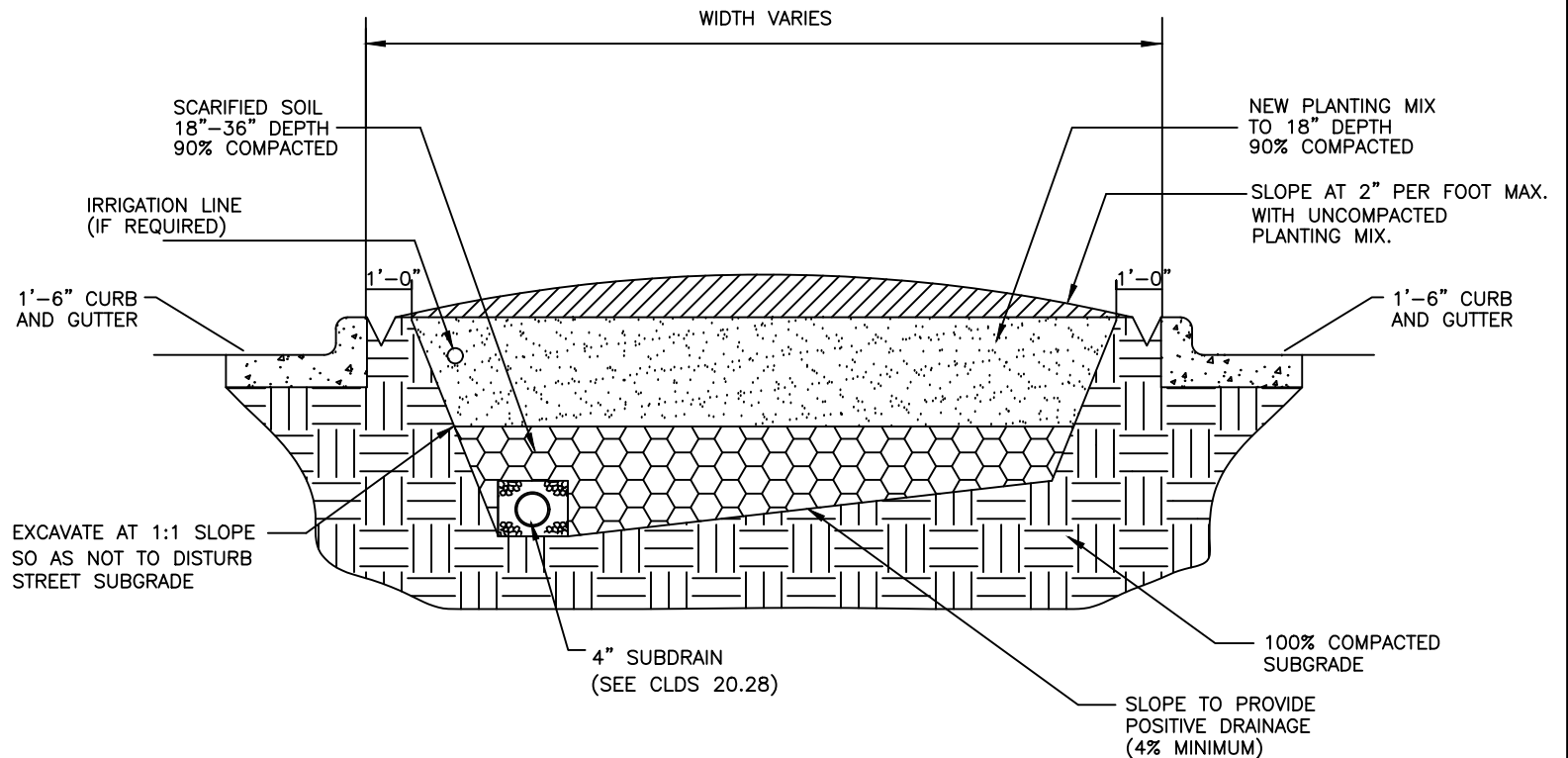

CITY OF CHARLOTTE
LAND DEVELOPMENT STANDARDS
INCLUDES CHARLOTTE ETJ

48 TO 72 INCH MEDIAN
EXCAVATION, DRAINAGE AND BACKFILL

STD. NO.	REV.
40.08C	23

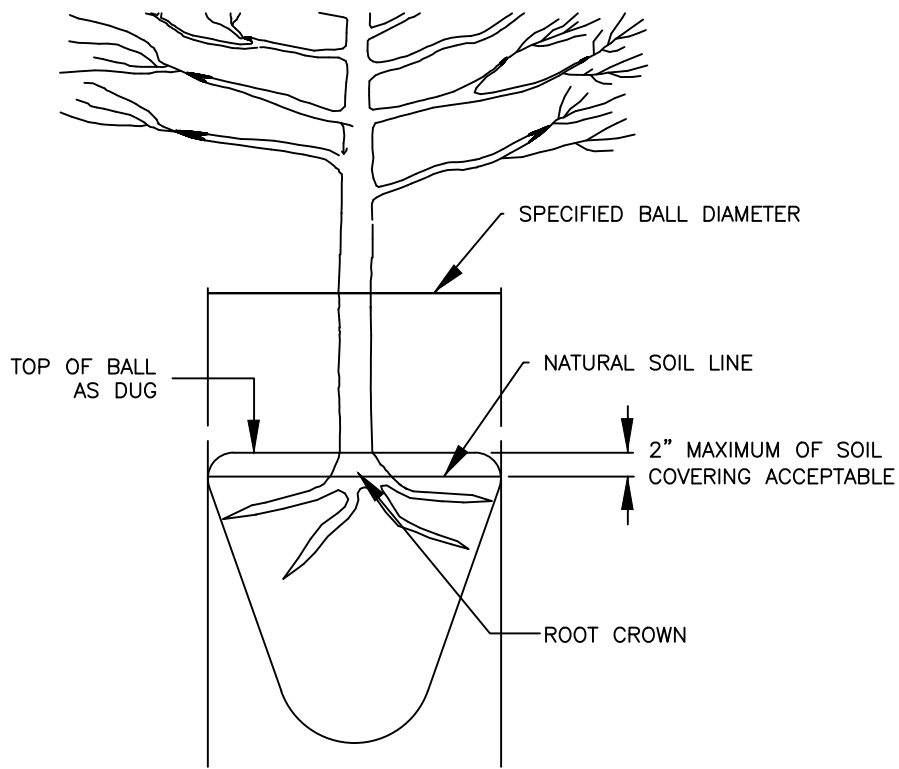

ACCEPTABLE CONDITION
(AS DELIVERED)

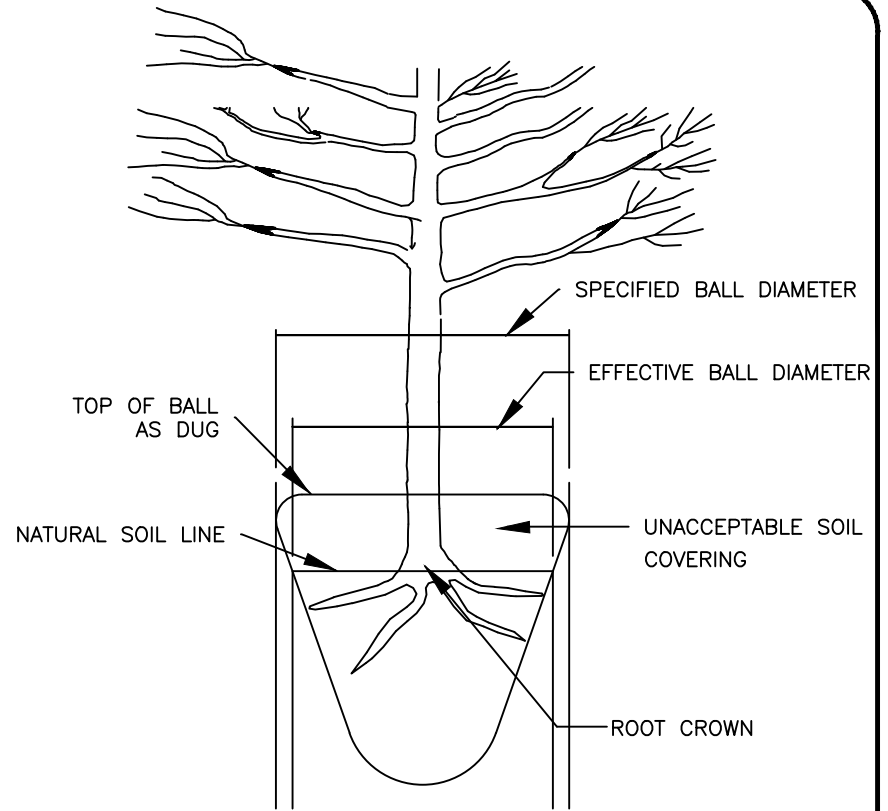

UNACCEPTABLE CONDITION
(AS DELIVERED)

NOTE:

A ROOT FLARE EXCAVATION FOR ALL TREES SPECIFIED WILL BE DONE BY THE CITY TO ENSURE THAT TREES WERE NOT PLANTED/GROWN TOO DEEPLY AT SOURCE (NURSERY). LANDSCAPE CONTRACTOR SHALL HAVE SUPPLIER MARK GROUND LEVEL LINE ABOVE ROOT BALL. IF THE CITY DETERMINES THAT THERE IS EXCESSIVE SOIL OVER THE ROOT CROWN, THESE TREES WILL BE REJECTED.



CITY OF CHARLOTTE
LAND DEVELOPMENT STANDARDS
INCLUDES CHARLOTTE ETJ

ROOT FLARE DEPTHS
(TREE ROOT BALL CONDITION ON TREES FROM SUPPLIERS)

STD. NO.	REV.
40.09	23

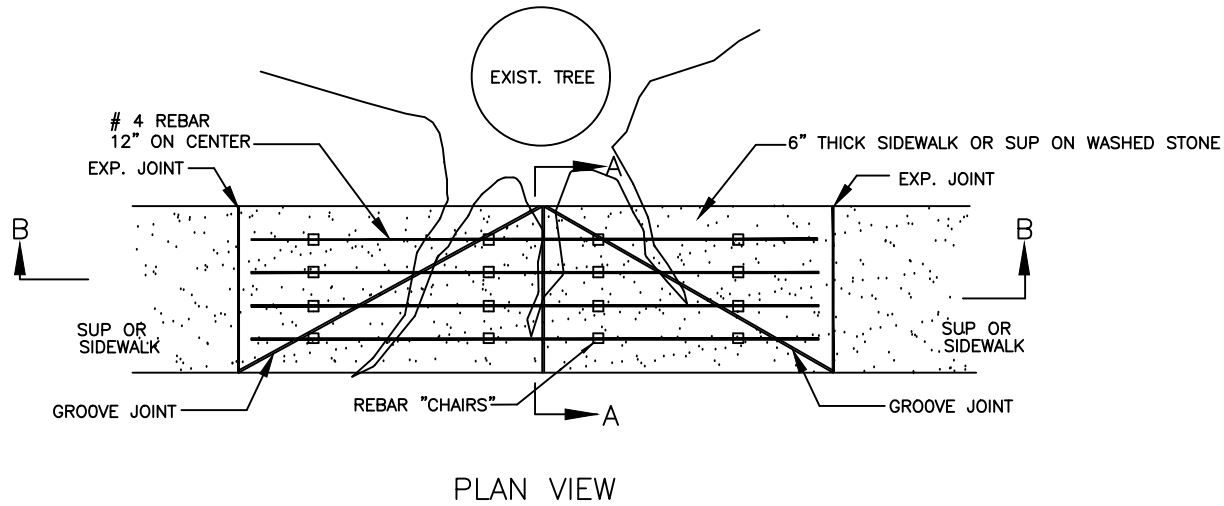

NOTES:

1. BRIDGING LENGTH IS A MINIMUM OF 1 LINEAR FOOT OF BRIDGING PER INCH OF DIAMETER AT BREAST HEIGHT (DBH). BASED ON FIELD CONDITIONS, MAY BE LONGER AS NEEDED.
2. NOT TO BE USED WHEN LESS THAN 4' WIDE PLANTING STRIP BETWEEN SIDEWALK AND BACK OF CURB.
3. SEE STD. NO 10.22 FOR SIDEWALK DETAILS.
4. SEE STD. NO 10.42 FOR SUP DETAILS.

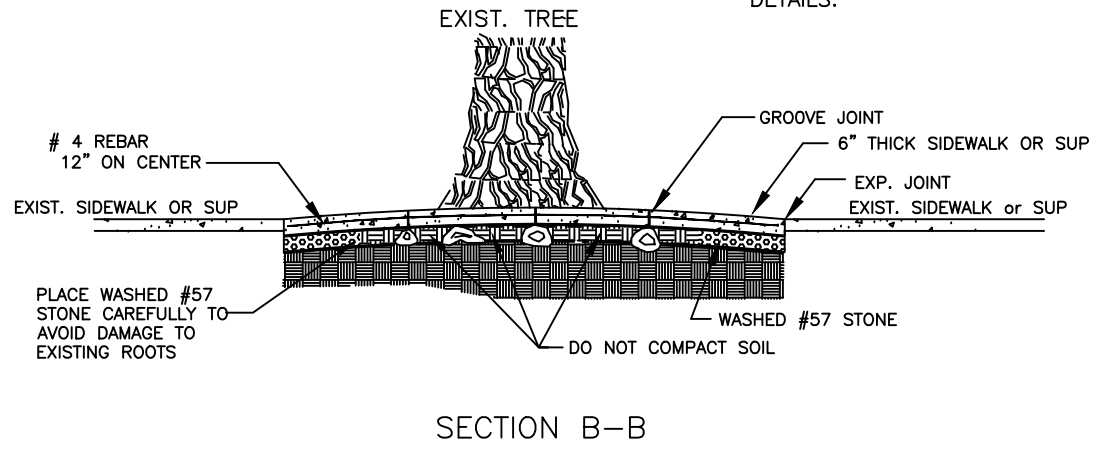
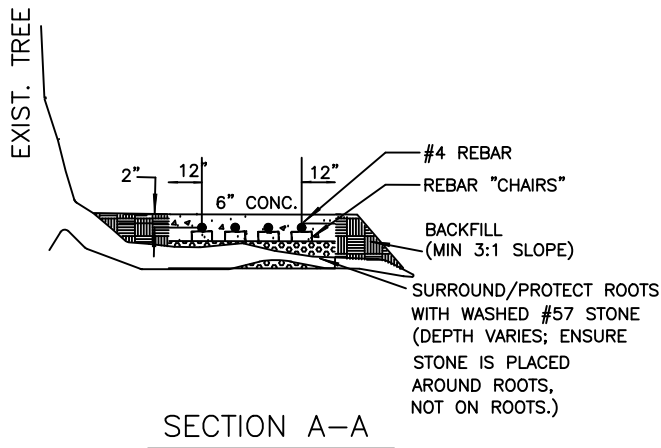

CITY OF CHARLOTTE
LAND DEVELOPMENT STANDARDS
INCLUDES CHARLOTTE ETJ

REINFORCED CONCRETE SIDEWALK/SUP
(BRIDGING TREE ROOTS)

STD. NO.	REV.
40.11	25

NOTES:

1. THIS TREE BUMPER DETAIL SHALL BE USED WHEN WORKING WITHIN 10' OF AN EXISTING TREE TO BE PROTECTED.
2. ALL TREES SHALL BE SAVED UNLESS NOTED OTHERWISE ON THE PLANS OR DIRECTED BY THE CITY.
3. LUMBER, WIRE, AND SANDBAGS MAY BE REUSED AT OTHER TREES.
4. THE INTENT OF THIS DETAIL IS TO PROTECT EXISTING TREES FROM DAMAGE DURING CONSTRUCTION AN ALTERNATE APPROACH MAY BE USED IF APPROVED IN WRITING BY THE CITY.

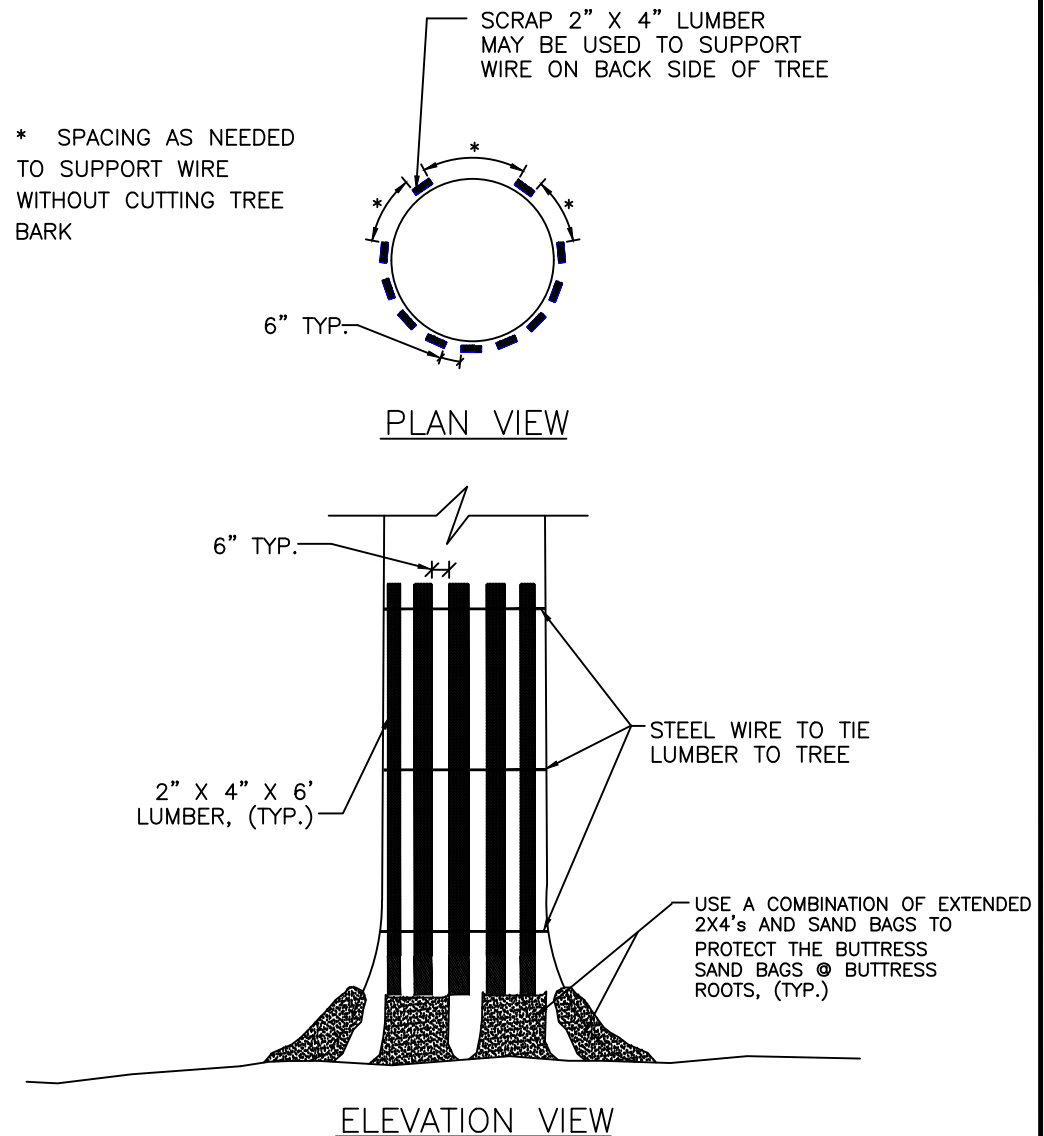

CITY OF CHARLOTTE
LAND DEVELOPMENT STANDARDS
INCLUDES CHARLOTTE ETJ

TEMPORARY TREE TRUNK
PROTECTION DETAIL

STD. NO.	REV.
40.12	23

NOTES:

1. CONTRACTOR SHALL USE EXTREME CAUTION WHEN WORKING NEAR EXISTING TREES.
2. WHERE EXISTING TREES ARE WITHIN 4' OF THE PROPOSED BACK OF CURB, THE PROPOSED CURB SHALL END A MINIMUM OF 12" FROM THE TREE'S BUTTRESS ROOTS.
3. CONTRACTOR SHALL COORDINATE WITH THE CITY TO IDENTIFY TREES FOR WHICH THIS DETAIL APPLIES PRIOR TO CONSTRUCTION NEAR THE TREE(S).
4. NO TREES SHALL BE REMOVED UNLESS CLEARLY SPECIFIED ON THE PLANS OR IDENTIFIED BY THE CITY.
5. AVOID FILL PLACEMENT NEAR TREE.

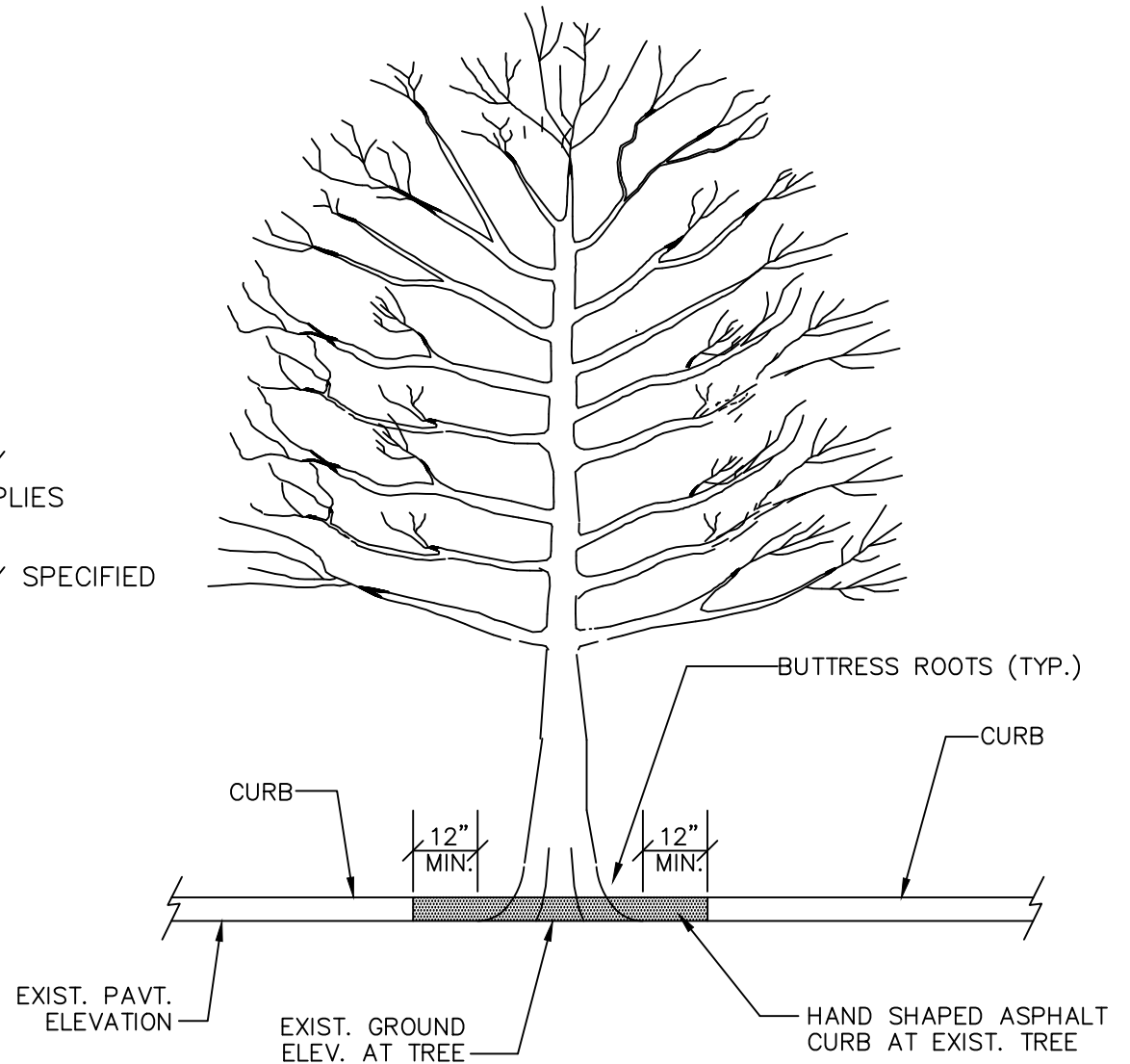

CITY OF CHARLOTTE
 LAND DEVELOPMENT STANDARDS
 INCLUDES CHARLOTTE ETJ

ASPHALT CURB PLACEMENT AT
 EXISTING TREES

STD. NO.	REV.
40.13	23

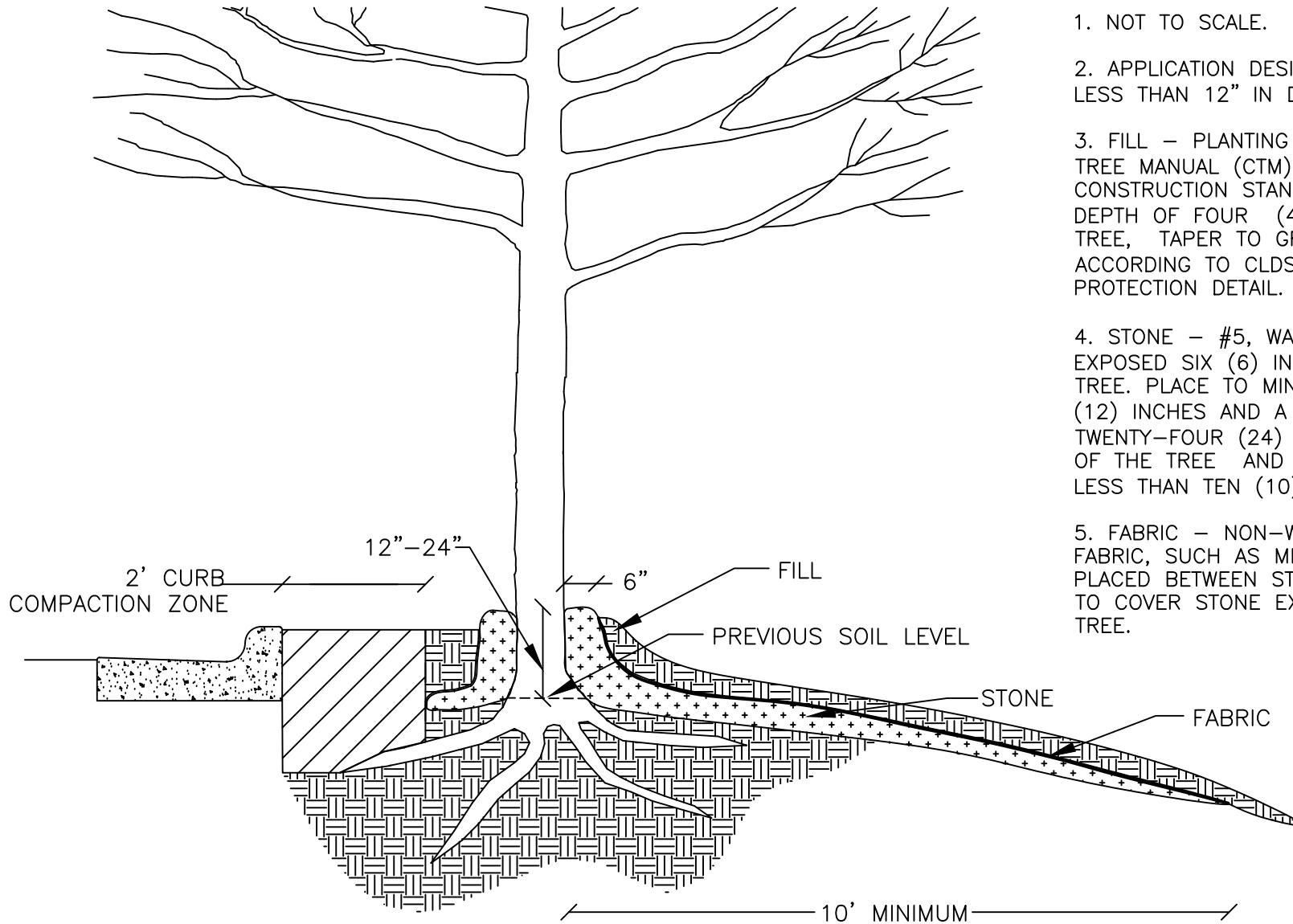

NOTES:

1. NOT TO SCALE.
2. APPLICATION DESIGNED FOR TREES NO LESS THAN 12" IN DIAMETER.
3. FILL - PLANTING MIX PER CHARLOTTE TREE MANUAL (CTM) AND LANDSCAPE CONSTRUCTION STANDARDS. APPLY TO A DEPTH OF FOUR (4) INCHES AT BASE OF TREE, TAPER TO GRADE. SEED AND MULCH ACCORDING TO CLDSM DETAIL #40.02, TREE PROTECTION DETAIL.
4. STONE - #5, WASHED. MAINTAIN EXPOSED SIX (6) INCH WIDTH AT TRUNK OF TREE. PLACE TO MINIMUM DEPTH OF TWELVE (12) INCHES AND A MAXIMUM OF TWENTY-FOUR (24) INCHES AT THE BASE OF THE TREE AND TAPER OUTWARD TO NO LESS THAN TEN (10) FEET.
5. FABRIC - NON-WOVEN GEOTEXTILE FABRIC, SUCH AS MIRAFLI OR EQUIVALENT, PLACED BETWEEN STONE AND FILL. IT IS NOT TO COVER STONE EXPOSED AT TRUNK OF TREE.



CITY OF CHARLOTTE
LAND DEVELOPMENT STANDARDS
INCLUDES CHARLOTTE ETJ

ROCK CHIMNEY

STD. NO.	REV.
40.14	23

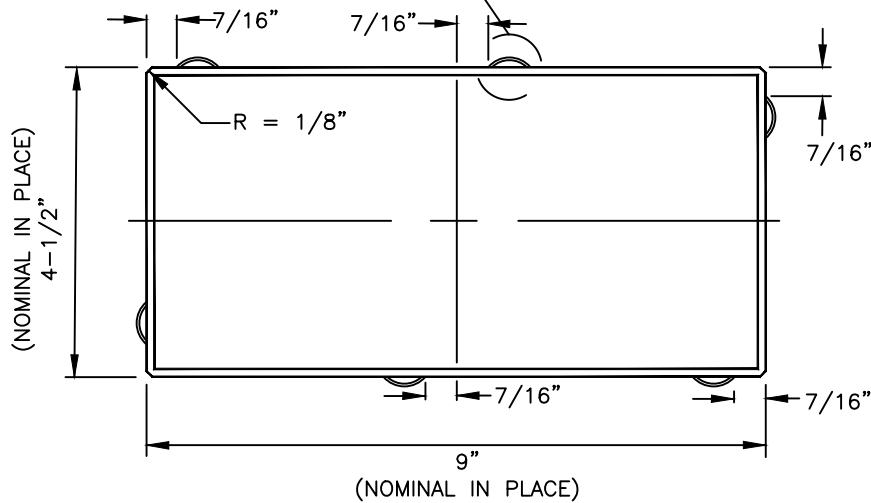
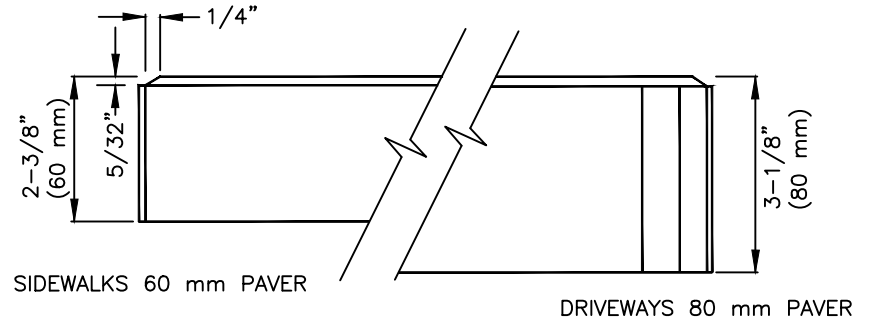
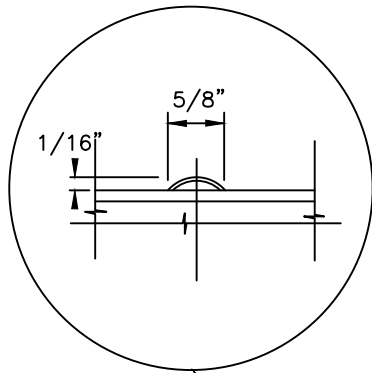

NOTES:

1. CONCRETE PAVERS PERMITTED UNDER AN ENCROACHMENT AGREEMENT WITH ALL APPLICABLE AGENCIES (CDOT OR NCDOT)
2. 4 1/2" x 9" x 60mm FOR SIDEWALKS
3. 4 1/2" x 9" x 80mm FOR DRIVEWAYS
4. BATCH DESIGN SHALL CONSIST OF 450 lbs. CEMENT / 2,085 lbs. AGGREGATES / MINIMUM 12 lbs. OF INORGANIC COLOR PIGMENT
5. COLOR SHALL BE A THREE-COLOR BLEND OF 15% BRICK RED, 35% MIDNIGHT BLACK, AND 50% BAJA RED TO CREATE A DARK ROSE, MOTTLED PAVEMENT SURFACE
6. PAVERS SHALL HAVE A UNIFORM SURFACE TEXTURE THAT IS NOT UNUSUALLY COARSE OR PITTED
7. SHALL BE INSTALLED ON A CONCRETE SUBSLAB BASE (50.01B)
8. PAVER JOINTS SHALL BE TIGHT AND FILLED WITH MANUFACTURED SAND FINES
9. VERTICAL SURFACE DISCONTINUITIES SHOULD BE MINIMIZED AND SHALL NOT EXCEED 1/4"

NOT TO SCALE



CITY OF CHARLOTTE
LAND DEVELOPMENT STANDARDS
INCLUDES CHARLOTTE ETJ

PRECAST CONCRETE PAVERS
FOR UPTOWN STREETScape

STD. NO.	REV.
50.01A	23

NOTES:

1. 4 1/2" X 9" X 60mm PAVERS FOR SIDEWALKS
2. 4 1/2" X 9" X 80mm PAVERS FOR DRIVEWAYS
3. THE BASE SLAB ELEVATION MAY HAVE TO BE ADJUSTED BY GRINDING AND/OR WITH MORTAR FILL TO PROVIDE A UNIFORM SAND LAYING COURSE THICKNESS OF ONE INCH
4. SIDEWALKS SHALL HAVE A DESIRED CROSS SLOPE OF 1.5% (2.00% MAXIMUM)
5. VERTICAL SURFACE DISCONTINUITIES SHOULD BE MINIMIZED AND SHALL NOT EXCEED 1/4"

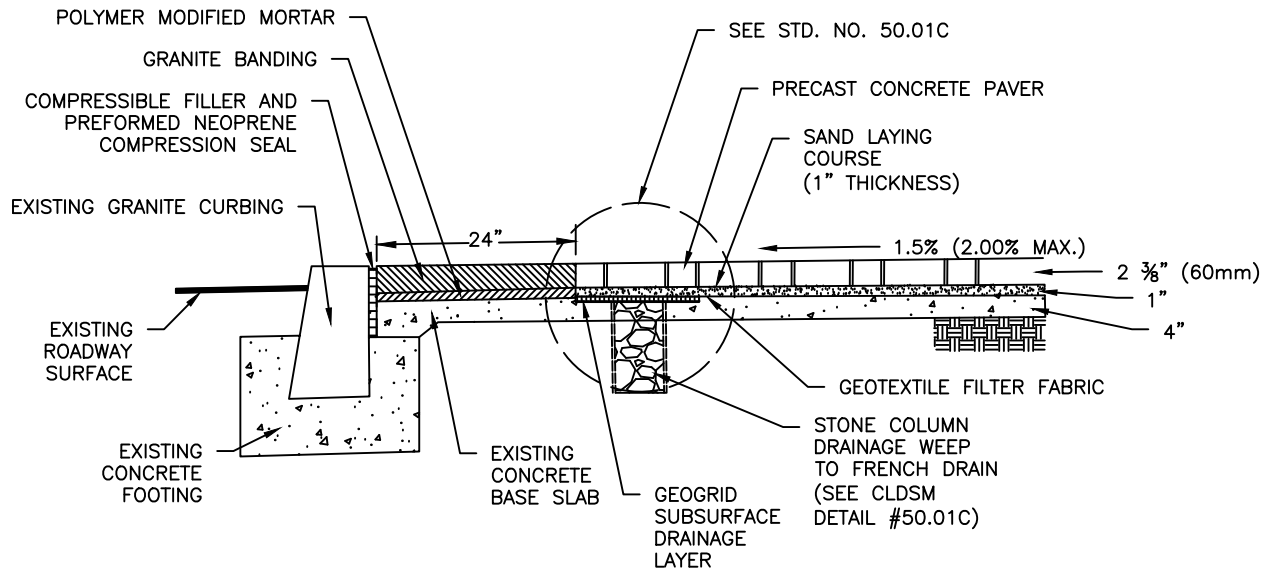

TYPICAL PAVER SIDEWALK SECTION WITH CONCRETE SUBSLAB BASE

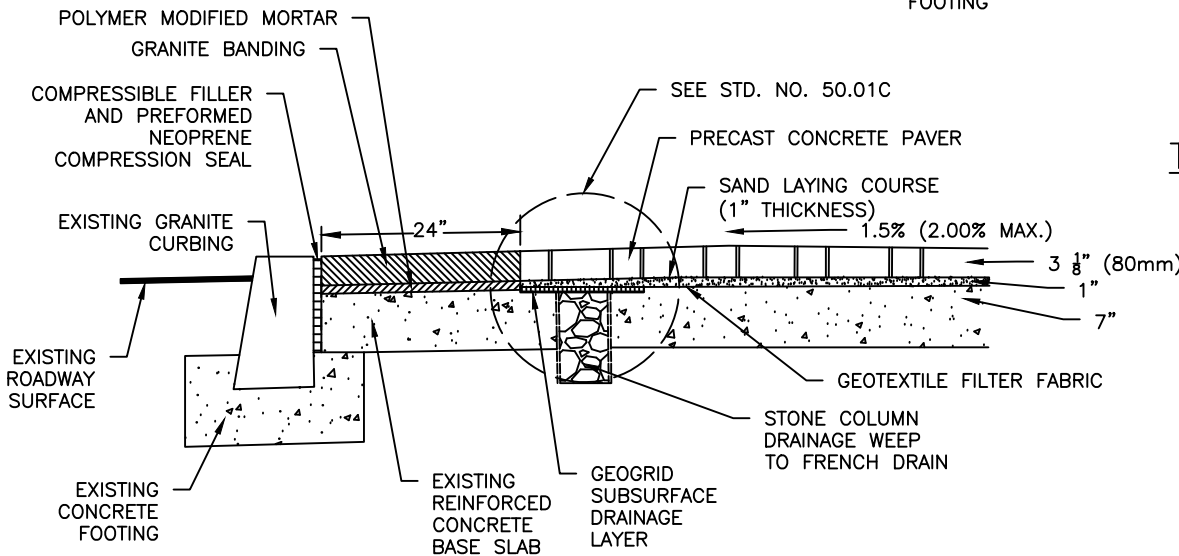

TYPICAL PAVER DRIVEWAY SECTION WITH CONCRETE SUBSLAB BASE

NOT TO SCALE



CITY OF CHARLOTTE
LAND DEVELOPMENT STANDARDS
 INCLUDES CHARLOTTE ETJ

PRECAST CONCRETE PAVERS
 FOR UPTOWN STREETScape

STD. NO.	REV.
50.01B	23

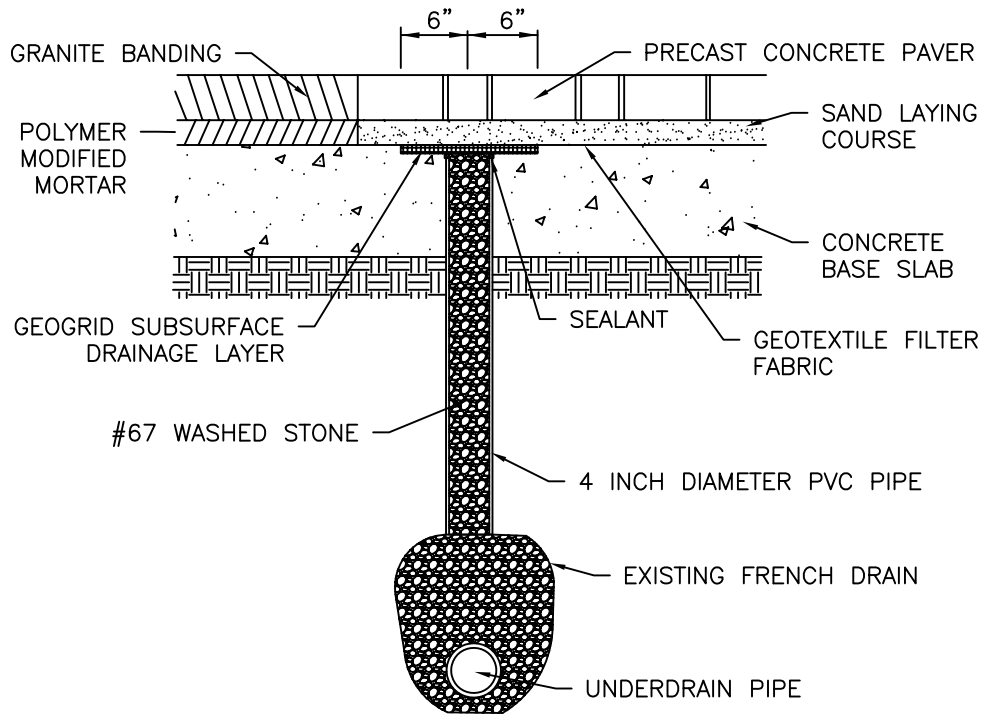

TYPICAL STONE COLUMN DRAINAGE WEEP

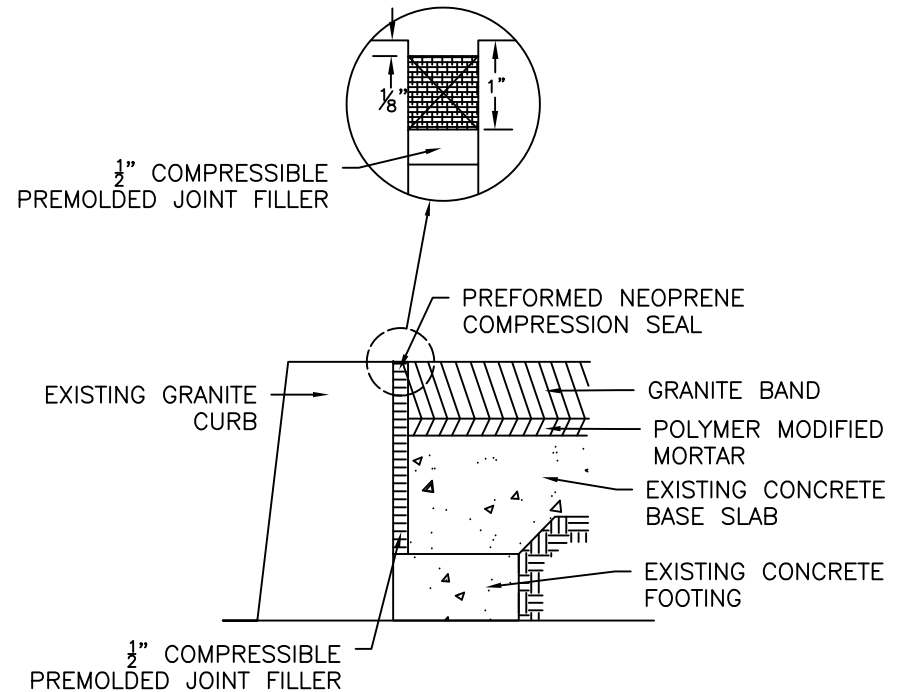

TYPICAL EXPANSION JOINT ON CONCRETE BASE SLAB AND CURB

NOTES:

1. SURFACE OF CONCRETE BASE SLAB TO BE LOWERED BY GRINDING OR OTHER MEANS TO OBTAIN 12 INCH STRIP OF GEOGRID SURFACE DRAINAGE LAYER

NOT TO SCALE



CITY OF CHARLOTTE
LAND DEVELOPMENT STANDARDS
INCLUDES CHARLOTTE ETJ

PRECAST CONCRETE PAVERS
FOR UPTOWN STREETSCAPE

STD. NO.	REV.
50.01C	23

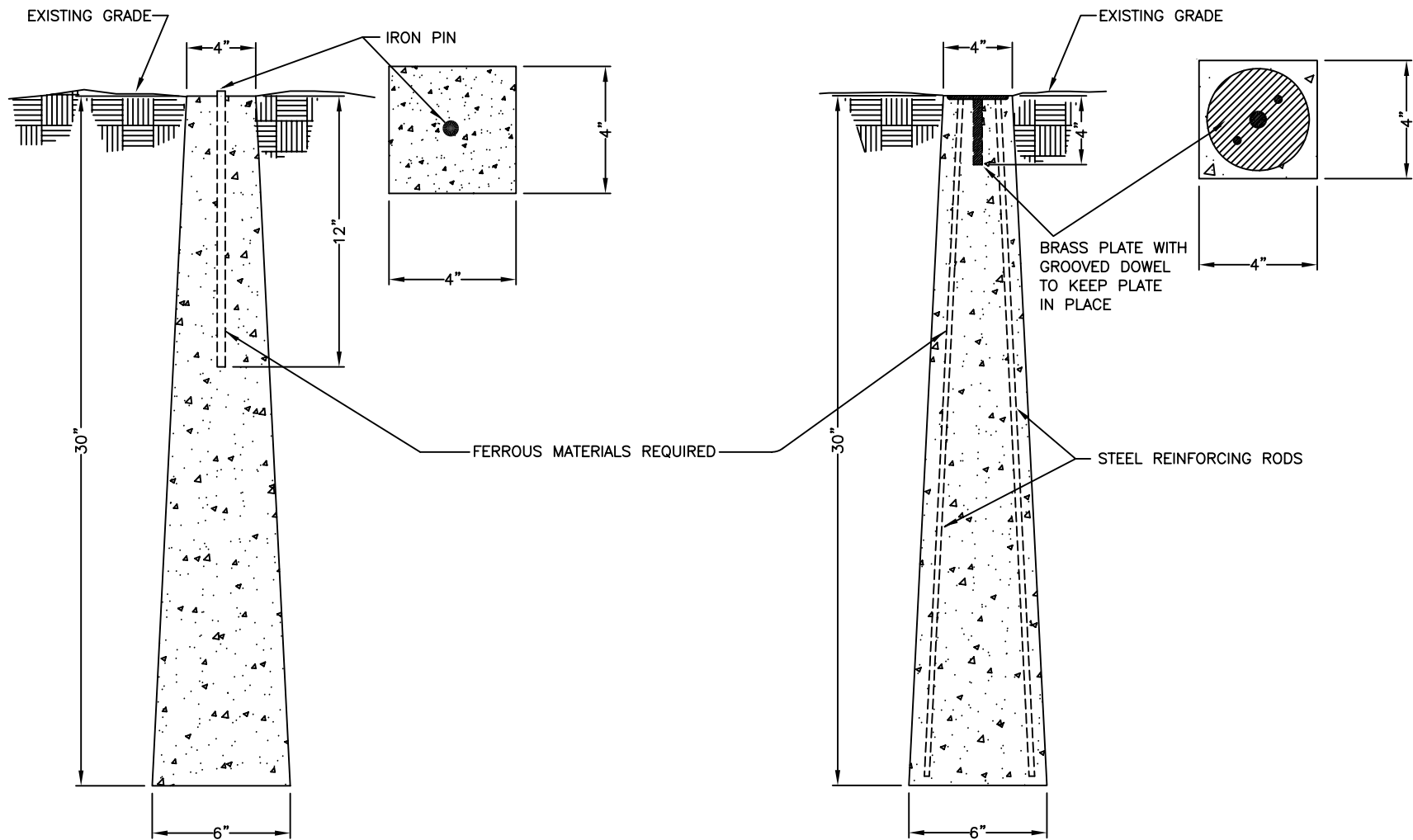

NOT TO SCALE



CITY OF CHARLOTTE
 LAND DEVELOPMENT STANDARDS
 INCLUDES CHARLOTTE ETJ

TYPICAL CONCRETE CONTROL MONUMENT

STD. NO.	REV.
50.03	

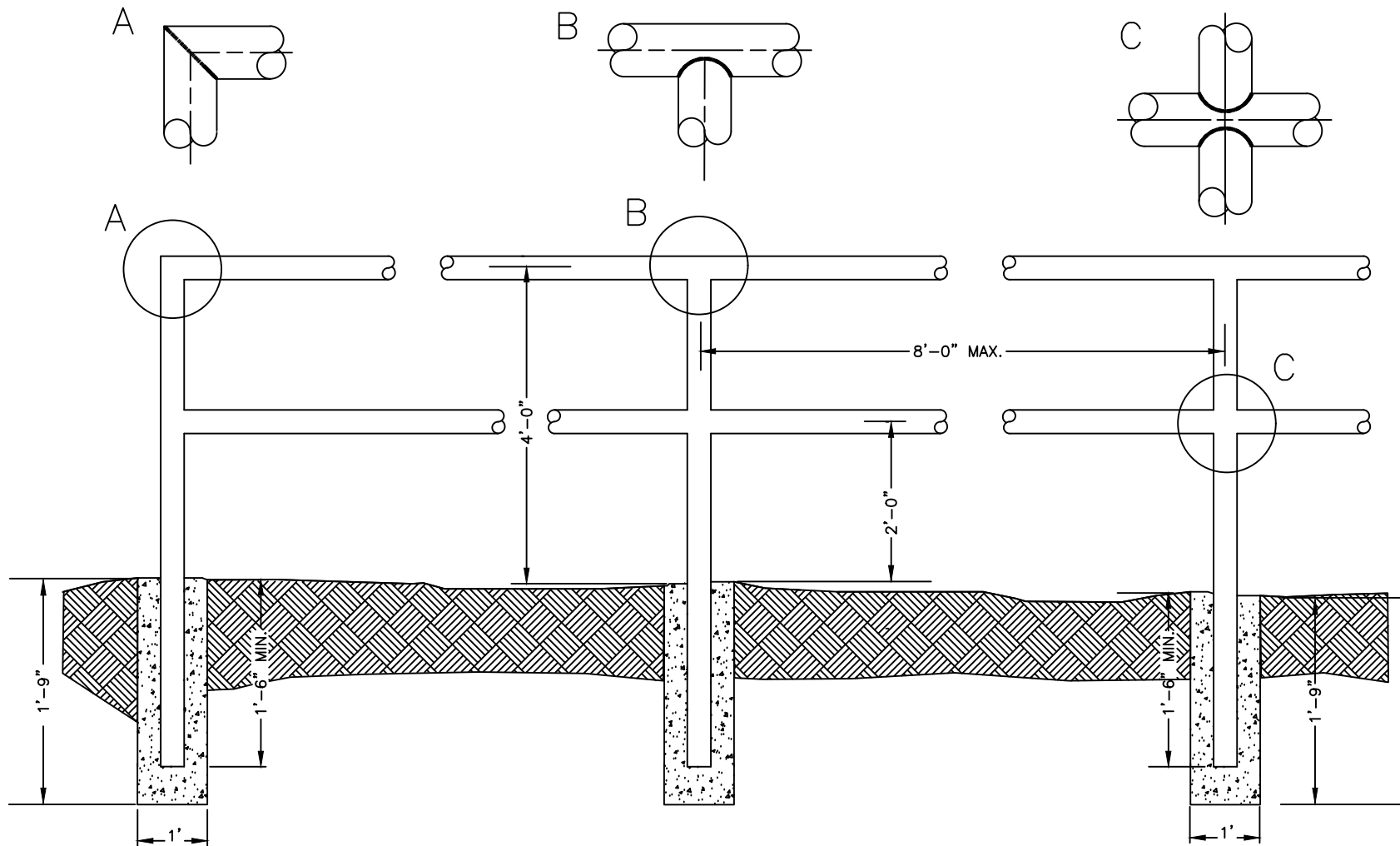

NOTES:

1. ALL CONCRETE TO BE 3600 P.S.I. COMPRESSIVE STRENGTH.
2. TYPE OF PIPE TO BE USED IS 1-5/8" MAX. O.D. BLACK IRON, LOW CARBON PIPE OR GALVANIZED.
3. ALL JOINTS TO HAVE A 1/2" FILLET WELD AT ALL JOINTS.
4. AFTER INSTALLATION PAINT ASSMBLY WITH BLACK ALL WEATHER ENAMEL.
5. SEE DETAIL 50.04-B FOR WARRANTS
6. ALTERNATIVE DESIGNS SHALL BE SENT TO CDOT FOR APPROVAL. ANY ALTERNATE DESIGN WILL BE PRIVATELY MAINTAINED.

NOT TO SCALE



**CITY OF CHARLOTTE
LAND DEVELOPMENT STANDARDS**
INCLUDES CHARLOTTE ETJ

SAFETY RAIL

STD. NO.	REV.
50.04A	16

WARRANTS

STANDARD SAFETY RAIL (STD. #50.04A) SHALL BE INSTALLED UNDER ANY OF THE FOLLOWING CIRCUMSTANCES IN BOTH NEW CONSTRUCTION AND IN RETROFITTING OR RECONSTRUCTION OF EXISTING ROADWAYS OR SITES:

1. WHEN THE CULVERT CROSSING DETAIL (STD. #10.36A-B) APPLIES.
2. IF THERE IS A TWO FOOT OR GREATER DROPOFF WITHIN 2 FEET OF THE EDGE OF THE SIDEWALK (SEE DIAGRAM A).
3. IF THERE IS A 1-FOOT OR LARGER DROPOFF DIRECTLY ADJACENT TO THE SIDEWALK EDGE (SEE DIAGRAM B).
4. AT THE DIRECTION OF CDOT, PLANNING, OR ENGINEERING STAFF BASED ON FIELD CONDITIONS.

DEFINITIONS

- DROPOFF -- A SLOPE OF 2:1 OR STEEPER. EXAMPLES INCLUDE HEADWALLS, RETAINING WALLS, AND CULVERTS.
- SIDEWALK -- FOR PURPOSES OF THIS STANDARD, THE TERM "SIDEWALK" IS USED GENERICALLY AND SHALL MEAN ANY PATH OR SURFACE TO BE USED FOR BICYCLE AND/OR PEDESTRIAN TRANSPORTATION. EXAMPLES INCLUDE, BUT ARE NOT LIMITED TO, SIDEWALKS, BIKE PATHS, SHARED-USE PATHS, PEDESTRIAN PATHS, AND GREENWAYS.

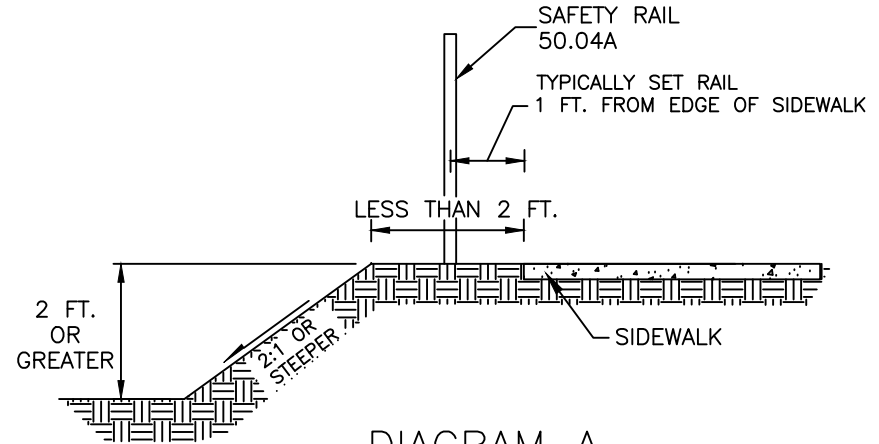

DIAGRAM A

SLOPED DROPOFF AT BACK OF SIDEWALK

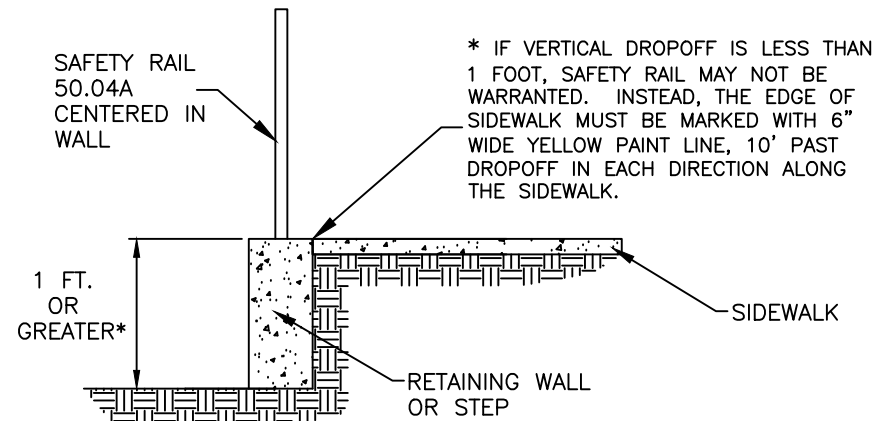

DIAGRAM B

VERTICAL DROPOFF AT BACK OF SIDEWALK

NOT TO SCALE



CITY OF CHARLOTTE
LAND DEVELOPMENT STANDARDS
INCLUDES CHARLOTTE ETJ

SAFETY RAIL WARRANTS

STD. NO.	REV.
50.04B	19

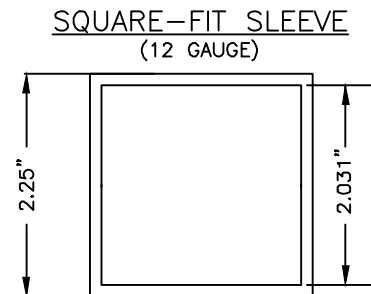
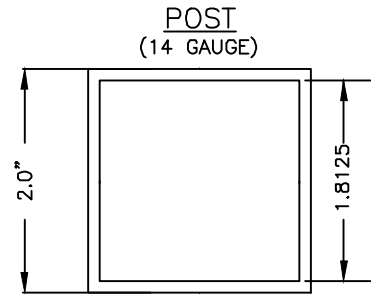
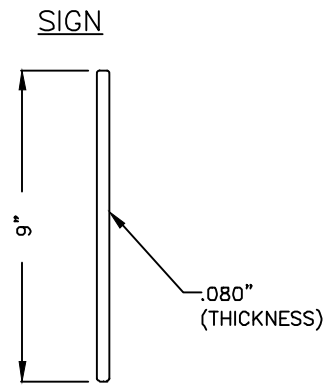

**STREET NAME SIGN
POST INSTALLATION**

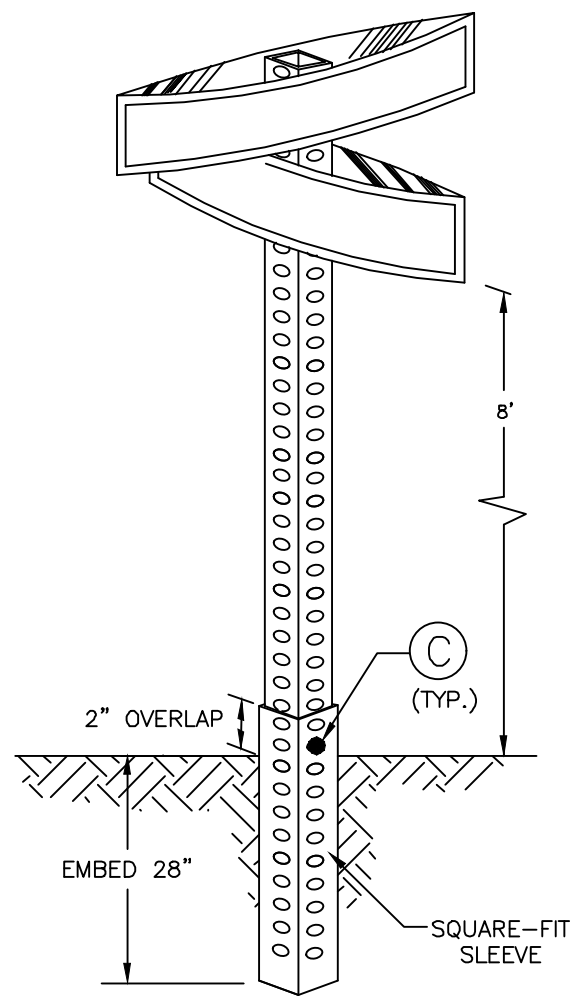

KEY TO FASTENERS:

- (A) #10-24 x 3/4" HEX HEAD MACHINE, ZINC- DEAD END
#10-24 FLANGE NUT, ZINC- DEAD END
- (B) 5/16" #16 X 3" CARRIAGE BOLT, ZINC
5/16" #16 HEX NUT, STEEL
- (C) 5/16" #16 X 2-3/4" CORNER BOLT (BREAKAWAY), ZINC
5/16" #16 HEX NUT, STEEL

NOTES:

1. POST SHALL BE 14-GAUGE GALVANIZED STEEL, QUIK-PUNCH, 7/16" HOLES, 1" ON CENTER, ALIGNED ON ALL SIDES, AND 2" SQUARE, 10 FEET IN LENGTH.
2. THE SLEEVE SHALL BE 12-GAUGE GALVANIZED STEEL, 7/16" HOLES, 1" ON CENTER, ALIGNED ON ALL SIDES, AND 2.25" SQUARE, 30" IN LENGTH.

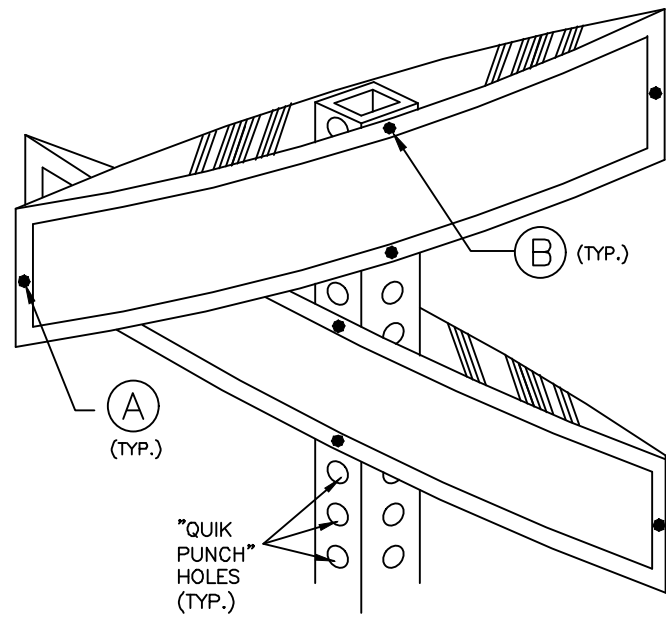

NOT TO SCALE



CITY OF CHARLOTTE
LAND DEVELOPMENT STANDARDS
INCLUDES CHARLOTTE ETJ

STREET NAME SIGN

STD. NO.	REV.
50.05A	23

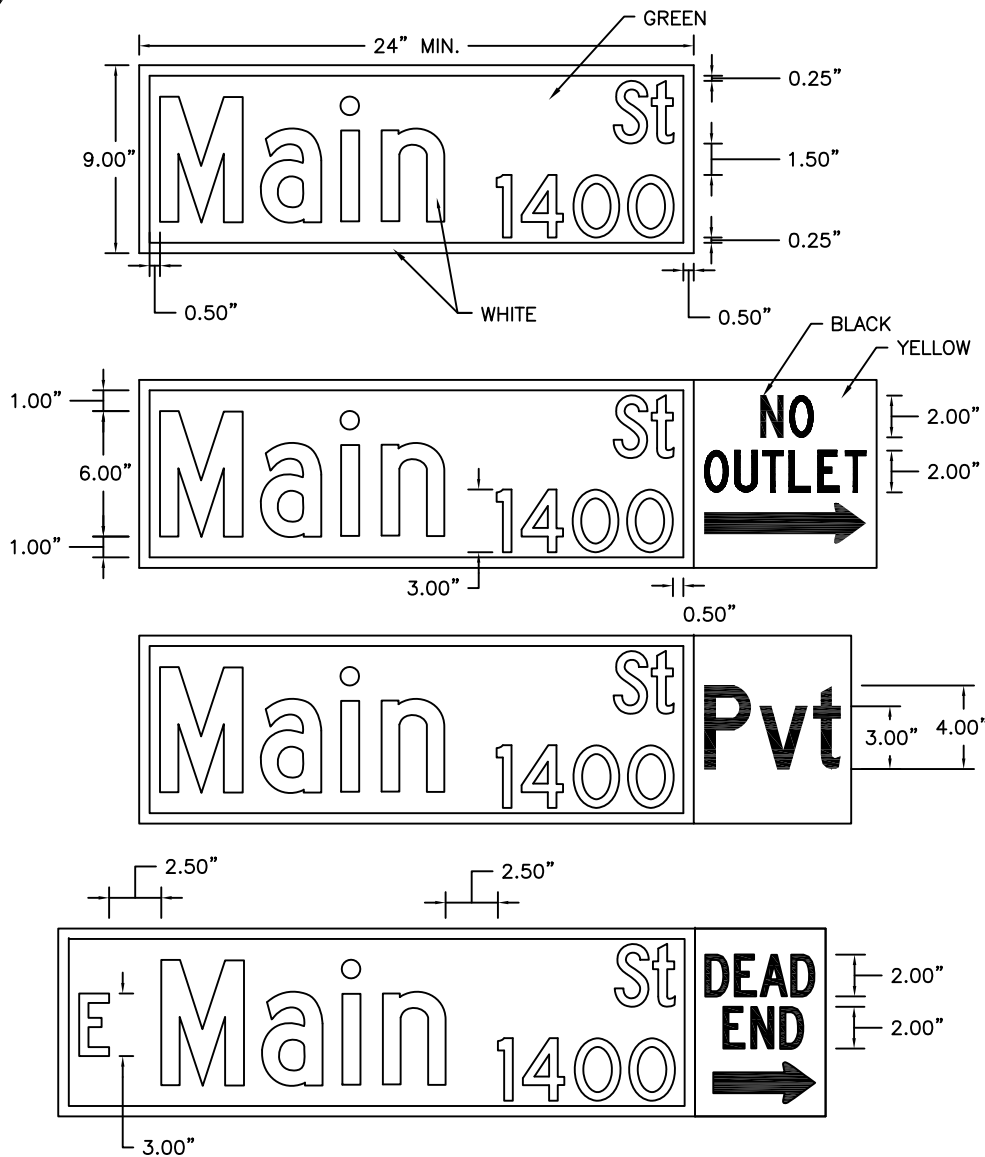

NOT TO SCALE

NOTES:

- STREET NAME MARKERS (SNM) SHALL BE ALUMINUM, FLAT, AND HAVE DIMENSIONS AS SHOWN ON THIS DETAIL. MINIMUM LENGTH OF 24"; MAXIMUM LENGTH OF 60". THE SNM'S SHALL BE COVERED WITH WHITE HIGH INTENSITY PRISMATIC (HIP) RETRO-REFLECTIVE SHEETING (3M SERIES 3930 OR EQUIVALENT) WITH PRESSURE SENSITIVE ADHESIVE (OR EQUIVALENT TYPE IV OR HIGHER).
- THE LETTERS SHALL BE REVERSE CUT FROM TRANSPARENT GREEN OVERLAY FILM (3M #1177 EC FILM OR EQUIVALENT MEETING FEDERAL SPECIFICATION FP-96, SECTION 178.01(A) AND ASTM D4956). THE TRANSPARENT GREEN OVERLAY FILM MUST BE PLACED ON THE SNM TO PROVIDE AN EXPOSED 0.5" BORDER OF THE UNDERLAY WHITE HIP RETRO-REFLECTIVE SHEETING.
- THE STREET NAME SHALL BE COMPOSED OF INITIAL UPPER CASE LETTERS 6" IN HEIGHT AND CORRESPONDING LOWER CASE LETTERS 4.5" IN HEIGHT, IN FHWA "HIGHWAY B" FONT. THE STREET NAME SHALL BE LEFT-JUSTIFIED AND PLACED 0.5" FROM THE SIGN BORDER. ANY STREET NAME WITH 3 OR FEWER LETTERS SHALL BE CENTERED IN THE SIGN TEXT AREA.
 - PREFIX/SUFFIX NAMES SHALL BE COMPOSED OF INITIAL UPPER CASE LETTERS 3" IN HEIGHT AND CORRESPONDING LOWER CASE LETTERS 2.25" IN HEIGHT, IN FHWA "HIGHWAY C" FONT.
 - BLOCK NUMBERS SHALL BE 3" IN HEIGHT, IN FHWA "HIGHWAY C" FONT.
 - SUFFIX NAMES AND BLOCK NUMBERS SHALL BE RIGHT-JUSTIFIED AND PLACED 0.5" FROM THE RIGHT-SIDE SIGN BORDER AND 0.25" FROM THE TOP AND BOTTOM SIGN BORDERS. PREFIX LETTERS (N, S, E, AND W) SHALL BE CENTERED AND PLACED 0.5" FROM THE LEFT-SIDE SIGN BORDER WITH 2.5" SPACING TO BEGINNING OF STREET NAME.
- SUPPLEMENTAL SNM WORDING ON YELLOW HIP RETRO-REFLECTIVE SHEETING WITH BLACK VINYL LETTERS SHALL BE PLACED ADJACENT TO THE GREEN OVERLAY FILM/BORDER TO INDICATE STREETS THAT DEAD END, HAVE NO OUTLET, ETC. OR ARE PRIVATE STREETS (PVT). THE YELLOW HIP RETRO-REFLECTIVE SHEETING MUST BE PLACED ON THE SNM TO MAINTAIN AN EXPOSED 0.5" BORDER OF THE UNDERLAY WHITE HIP RETRO-REFLECTIVE SHEETING.
 - NO OUTLET WITH ARROW (RIGHT OR LEFT) - PLACED ON SNM AT ENTRANCE TO A STREET OR STREET NETWORK FROM WHICH THERE IS NO OTHER EXIT. USE UPPER CASE LETTERS 2" IN HEIGHT, IN FHWA "HIGHWAY C" FONT.
 - PVT - PLACED ON SNM AT ENTRANCE TO PRIVATE STREET, USE UPPER CASE LETTER 4" IN HEIGHT AND CORRESPONDING LOWER CASE LETTERS 3" IN HEIGHT, IN FHWA "HIGHWAY C" FONT.
 - DEAD END WITH ARROW (RIGHT OR LEFT) - PLACED ON SNM AT ENTRANCE TO A SINGLE STREET THAT TERMINATES IN A DEAD END OR CUL-DE-SAC. USE UPPER CASE LETTERS 2" IN HEIGHT, IN FHWA "HIGHWAY C" FONT. IF STUB STREET IS LESS THAN OR EQUAL TO 200 FEET, THEN DEAD END IS NOT NECESSARY.
- ALL SNMs ARE SUBJECT TO THE APPROVAL OF THE DIRECTOR OF THE CHARLOTTE DEPARTMENT OF TRANSPORTATION AND THE CITY ENGINEER.



CITY OF CHARLOTTE
 LAND DEVELOPMENT STANDARDS
 INCLUDES CHARLOTTE ETJ

STREET NAME SIGN

STD. NO.	REV.
50.05B	9

INTERSECTION with
SIDEWALK, CURB, and GUTTER

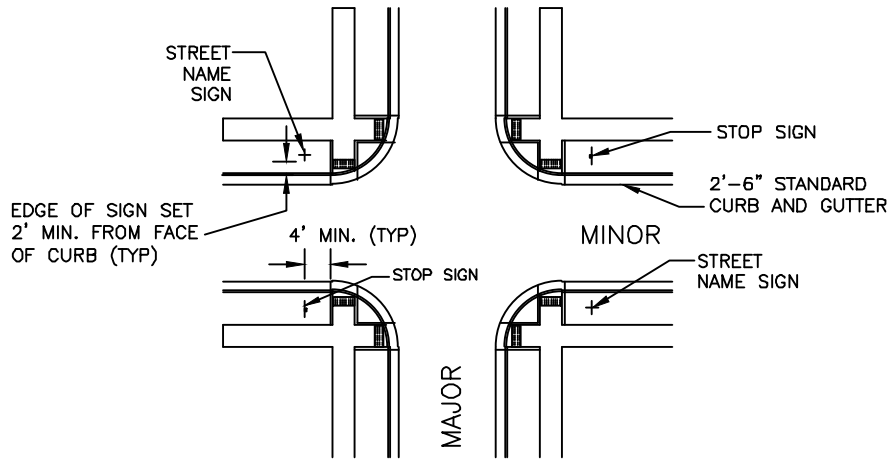

INTERSECTION with CURB and GUTTER

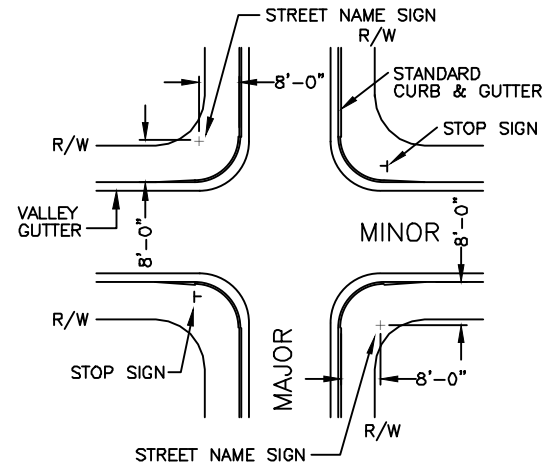

INTERSECTION with
DITCHES, and NO CURB and GUTTER

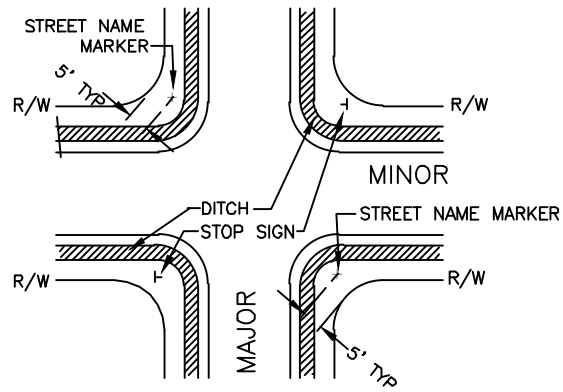

NOTES

1. TWO STREET NAME MARKERS ARE REQUIRED IF THE MAJOR STREET HAS 3 OR MORE LANES.
2. ANY VARIANCE FROM THIS STANDARD MUST BE APPROVED BY THE CHARLOTTE DEPARTMENT OF TRANSPORTATION.
3. ENSURE STOP SIGN SIZE AND INSTALLATION PER MUTCD STANDARDS.

NOT TO SCALE



CITY OF CHARLOTTE
LAND DEVELOPMENT STANDARDS
INCLUDES CHARLOTTE ETJ

STREET SIGN INSTALLATION
LOCATIONS

STD. NO.	REV.
50.06	13

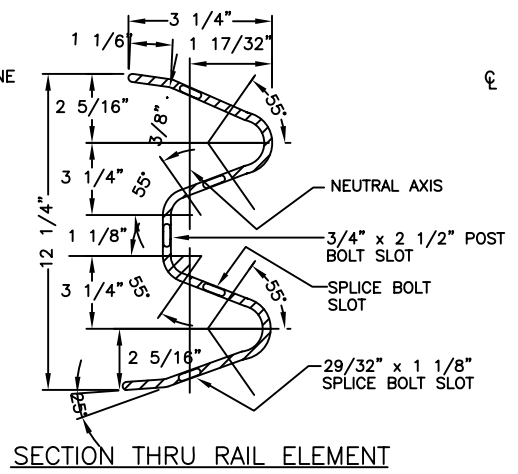
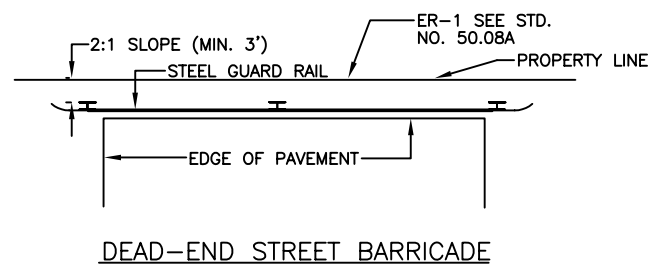
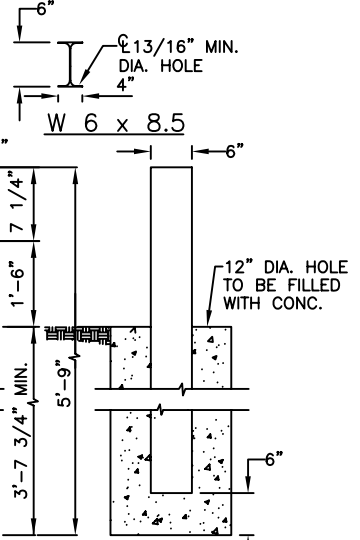
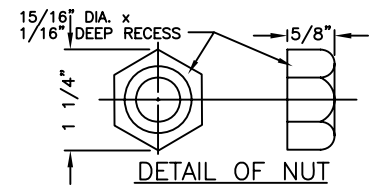
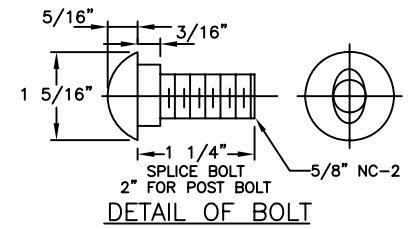
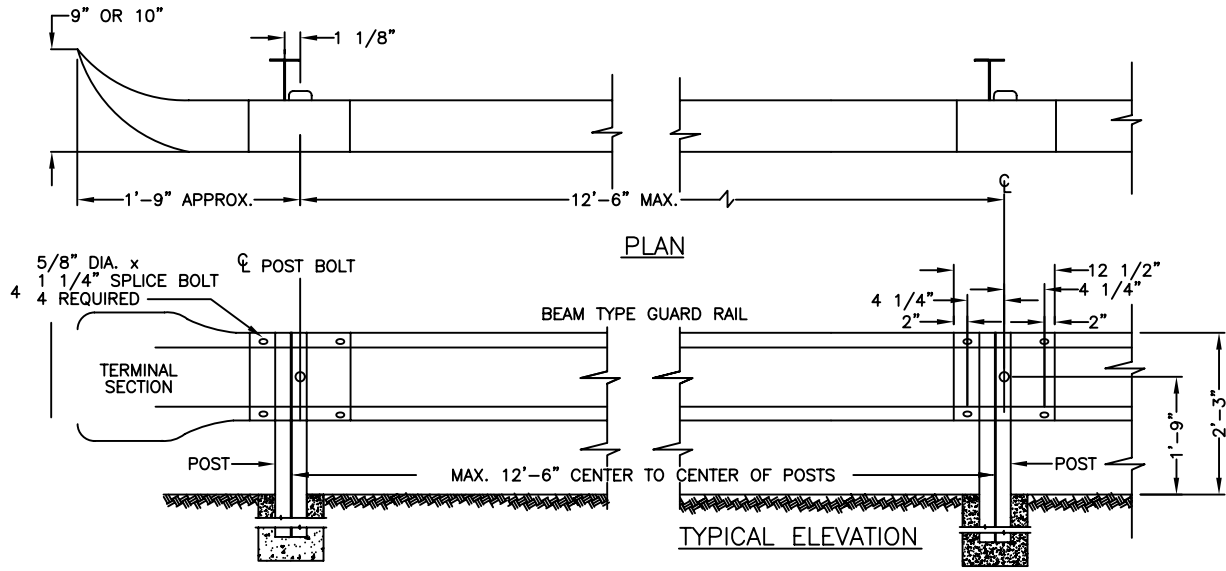

NOTE
 THIS DETAIL IS NOT A GUARDRAIL DETAIL. FOR
 ROADSIDE GUARDRAIL, SEE NCDOT STANDARD
 DRAWINGS 862.01-862.03

APPROVED DATE

NOT TO SCALE



CITY OF CHARLOTTE
LAND DEVELOPMENT STANDARDS
 INCLUDES CHARLOTTE ETJ

DEAD END STREET BARRICADE

STD. NO.	REV.
50.07A	

GENERAL NOTES:

1. STEEL BEAM TYPE GUARD RAILS SHALL BE INSTALLED AT THE END OF ALL DEAD-END STREETS, EXCEPT CUL-DE-SAC STREETS WHICH HAVE BEEN IMPROVED WITH A PERMANENT TURN-AROUND.
2. FOR STREETS 26' IN WIDTH THE GUARD RAIL SHALL CONSIST OF TWO(2) 12'-6" SECTIONS OR ONE(1) 25' SECTION, THREE (3) STEEL POSTS, AND TWO (2) TERMINAL SECTIONS. FOR STREETS GREATER THAN 25' IN WIDTH THE GUARD RAIL SHALL SPAN THE ENTIRE WIDTH OF THE STREET.
3. GUARD RAIL SHALL CONSIST OF RAIL ELEMENTS FABRICATED TO DEVELOP CONTINUOUS BEAM STRENGTH AND INSTALLED AS SHOWN.
4. MINIMUM THICKNESS OF GUARD RAIL SHALL BE 12 GAGE U.S. STANDARD.
THE RAIL ELEMENT INCLUDING SPLICES, SHALL HAVE A MINIMUM ULTIMATE TENSILE STRENGTH OF 80,000 LBS.
GUARD RAIL PARTS FURNISHED SHALL BE INTERCHANGEABLE WITH SIMILAR PARTS REGARDLESS OF THE SOURCE OF MANUFACTURER.
THE HOLES FOR CONNECTING BOLTS SHALL BE PUNCHED OR DRILLED, BURNING WILL NOT BE PERMITTED.
5. THE GUARD, BOLTS, NUTS, STEEL POSTS. AND ALL OTHER METAL PARTS SHALL BE GALVANIZED TO CONFORM TO THE REQUIREMENTS FOR THE COATING CLASS, (2.50 OUNCES PER SQUARE FOOT) OF THE CURRENT SPECIFICATIONS FOR ZINC-COATED (GALVANIZED) IRON, AND STEEL SHEETS, COILS, AND CUT LENGTHS, IN ACCORDANCE WITH ASTM 123A.
6. IF THE AVERAGE SPELTER COATING AS DETERMINED FROM THE REQUIRED SAMPLES IS LESS THAN TWO (2) OUNCES OF SPELTER PER SQUARE FOOT, OR IF ANY ONE SPECIMEN HAS LESS THAN 1.8 ONCES OF SPELTER PER SQUARE FOOT OF DOUBLE EXPOSED SURFACE, THE LOT SAMPLED SHALL BE REJECTED, THE FINISHED SHEETS SHALL BE OF FIRST CLASS COMMERCIAL QUALITY, FREE FROM INJURIOUS DEFECTS, SUCH AS BLISTERS, FLUX, AND UNCOATED SPOTS.
7. THE GUARD RAIL SHALL BE INSPECTED TO DETERMINE THAT THE MATERIAL, DIMENSIONS, AND WORKMANSHIP ARE IN ACCORDANCE WITH THIS PLAN.
8. WHERE A DEAD-END STREET REQUIRES GUARD RAIL, END OF ROADWAY MARKER SIGNS SHALL ALSO BE REQUIRED.
(SEE STD. 50.08A & 50.08B) (ER-1).

NOT TO SCALE



CITY OF CHARLOTTE
LAND DEVELOPMENT STANDARDS
INCLUDES CHARLOTTE ETJ

DEAD END STREET BARRICADE
GENERAL NOTES

STD. NO.	REV.
50.07B	

NOTES:

1. WHEN A DEAD-END OR STUBBED STREET REQUIRES A GUARDRAIL SECTION, END-OF-ROADWAY MARKER SIGNS (OM4-3, 24"x24", SOLID RED) SHALL BE PROVIDED.
2. SIGNS ARE TO BE PLACED BEHIND THE BARRICADE (SEE DETAILS 50.07A-B), EVENLY SPACED WITH ONE SIGN PLACED AT THE CENTERLINE LOCATION AND ADDITIONAL SIGNS AT 6' O.C. (MINIMUM OF 3 SIGNS, MAXIMUM OF 5 SIGNS).
3. WHEN BARRICADE IS USED ON A STREET STUB, THE SIGN AT THE CENTERLINE SHALL BE SUPPLEMENTED WITH A STREET CONNECTIVITY SIGN. SEE DETAIL 50.08C.
4. ALL SIGNS/MARKERS SHALL MEET OR EXCEED MUTCD STANDARDS FOR RETROREFLECTIVITY.

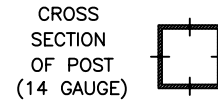
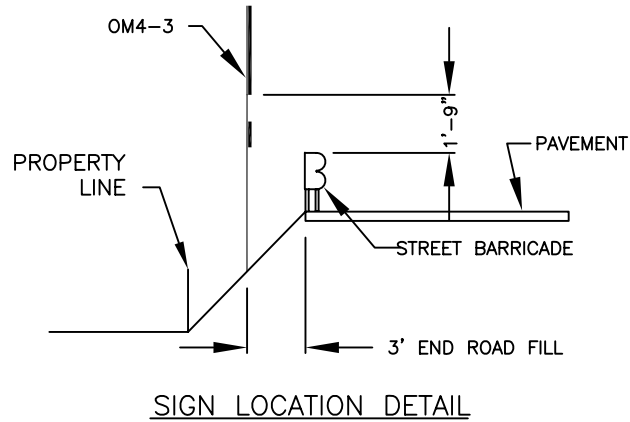

CONNECTIVITY SIGN SEE NOTE #3

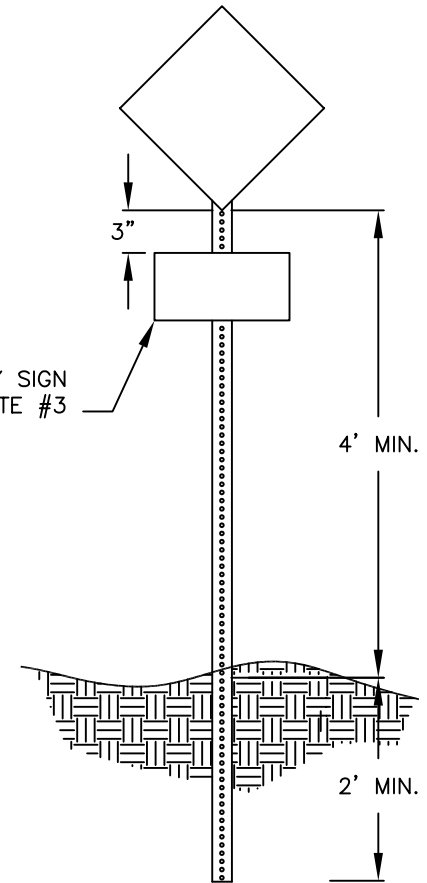
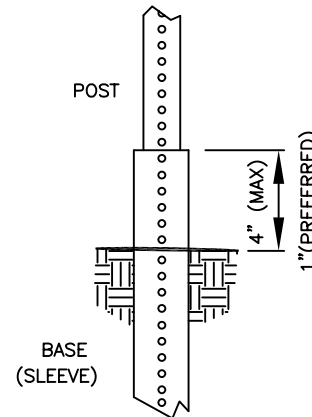
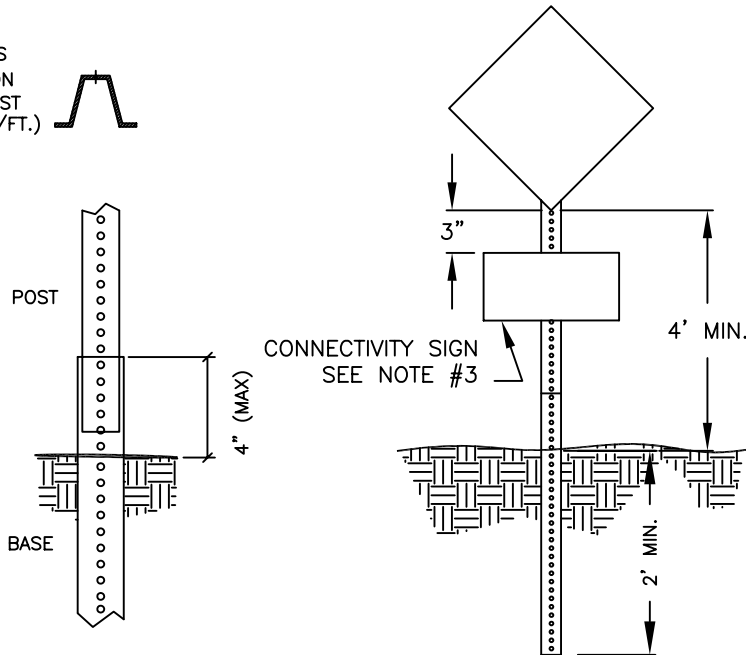

NOT TO SCALE



CITY OF CHARLOTTE
LAND DEVELOPMENT STANDARDS
 INCLUDES CHARLOTTE ETJ

END OF ROADWAY MARKER

STD. NO.	REV.
50.08A	4

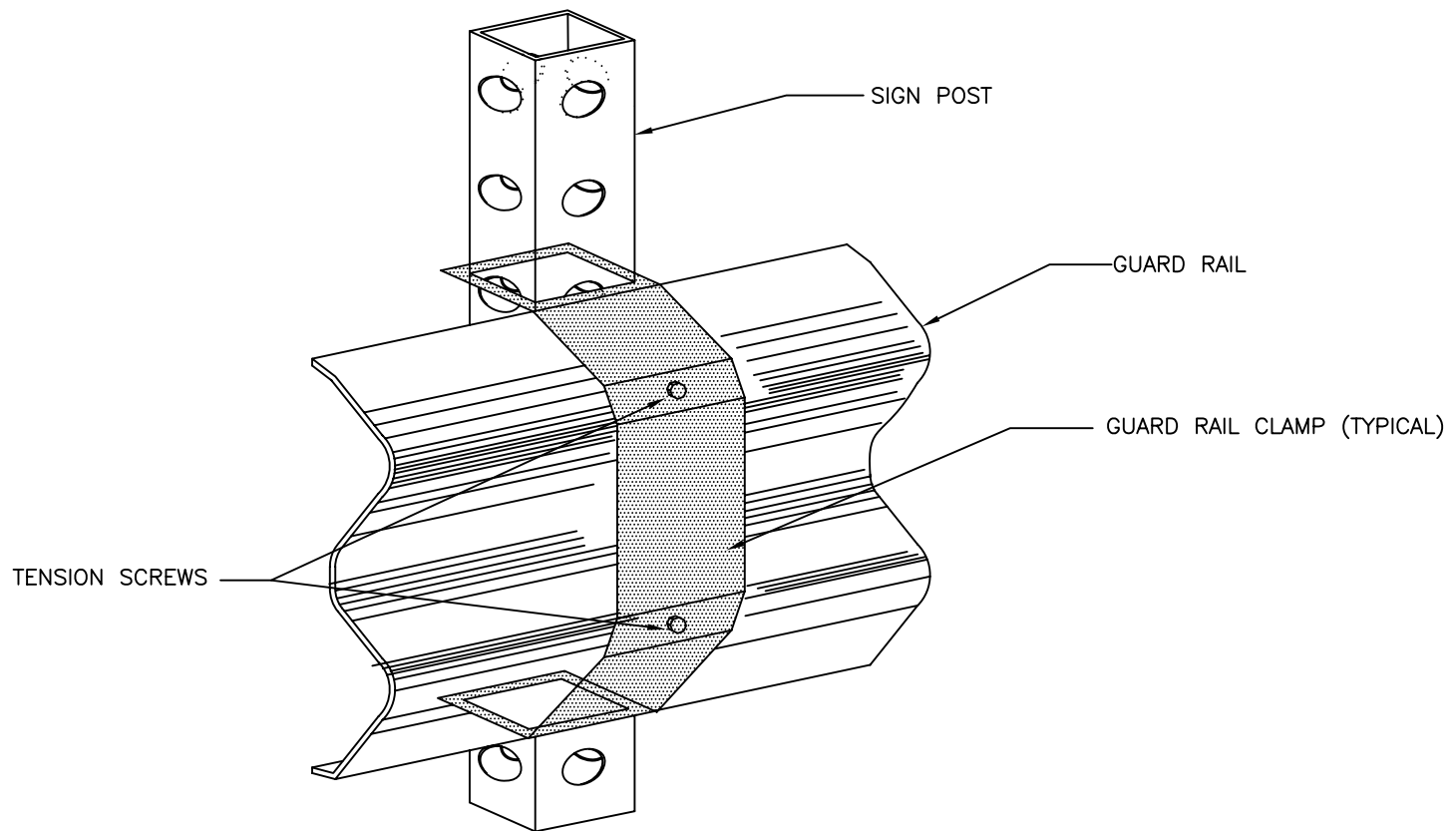

NOT TO SCALE



CITY OF CHARLOTTE
 LAND DEVELOPMENT STANDARDS
 INCLUDES CHARLOTTE ETJ

END OF ROADWAY MARKER
 GUARD RAIL CLAMP INSTALLATION

STD. NO.	REV.
50.08B	4

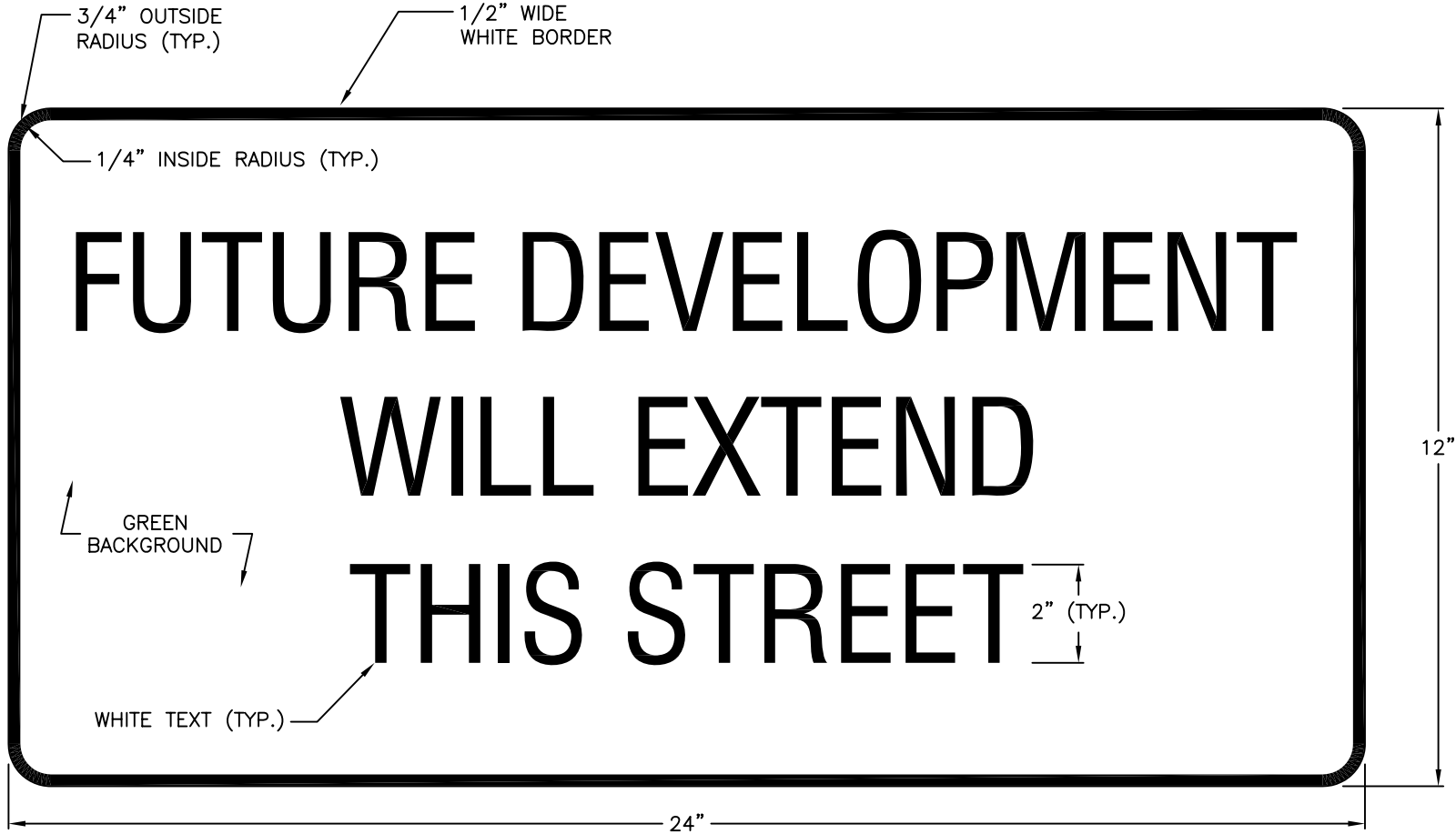

NOTES:

1. SIGN SHALL MEET OR EXCEED MUTCD STANDARDS FOR RETROREFLECTIVITY
2. SIGN MATERIAL SHALL BE 0.080" THICK ALUMINUM
3. ALL LETTERS SHALL BE SERIES B-2000 FROM THE 2004 STANDARD HIGHWAY SIGNS MANUAL (AND ANY REVISION THERETO) PUBLISHED BY THE FEDERAL HIGHWAY ADMINISTRATION.

NOT TO SCALE



**CITY OF CHARLOTTE
LAND DEVELOPMENT STANDARDS**
INCLUDES CHARLOTTE ETJ

STREET CONNECTIVITY SIGN
FOR END-OF-ROAD BARRICADE

STD. NO.	REV.
50.08C	4

PARKING ANGLE 90°
(TWO WAY OPERATION ONLY)

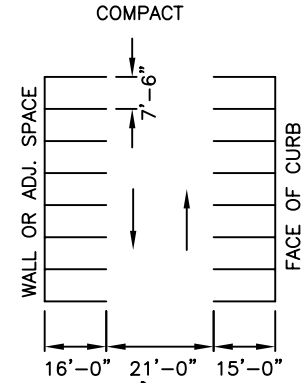
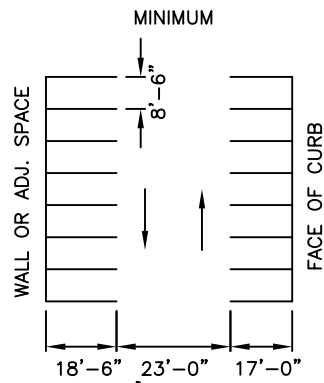
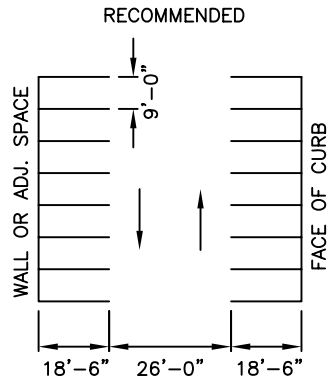

PARKING ANGLE 60°
(ONE WAY OPERATION ONLY)

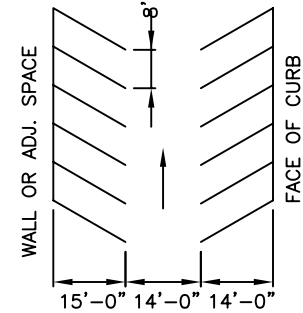
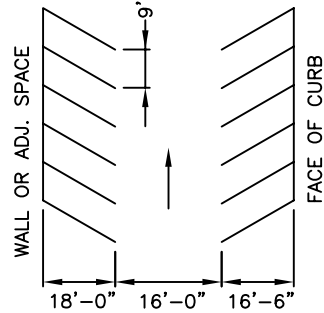
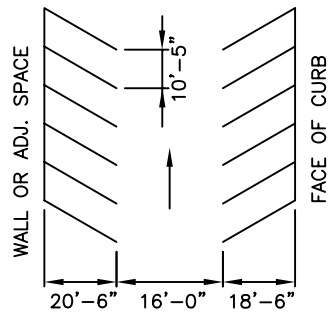

PARKING ANGLE 45°
(ONE WAY OPERATION ONLY)

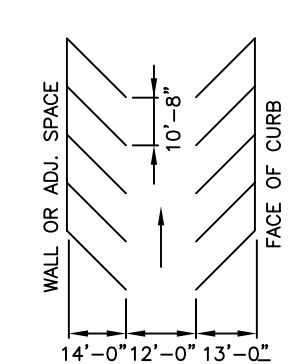
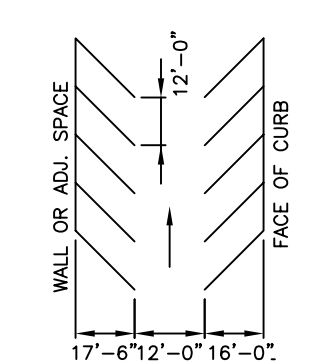
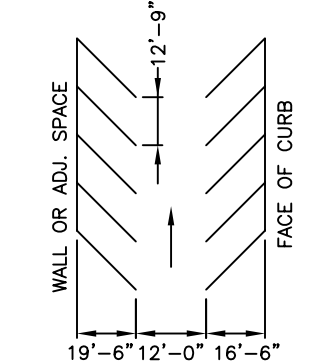

NOTES:

1. FOR ACCESSIBLE PARKING STANDARDS/SIGNAGE SEE STDS. 50.10A, B, AND C.
2. PAVEMENT MARKINGS SHALL BE 4" WHITE PAINT.
3. ALTERNATIVE PARKING ANGLES, AISLE WIDTHS, AND OPERATION (TWO-WAY ANGLED PARKING OR REVERSE-ANGLE PARKING) WILL BE CONSIDERED BY CDOT ON A CASE-BY-CASE BASIS.

NOT TO SCALE



CITY OF CHARLOTTE
LAND DEVELOPMENT STANDARDS
INCLUDES CHARLOTTE ETJ

PARKING STANDARDS

STD. NO.	REV.
50.09A	

SIDEWALK ADJACENT TO HEAD-IN OR BACK-IN PARKING SHALL BE AT LEAST 7 FEET WIDE.

PARKING ON ONE SIDE OF A SIDEWALK

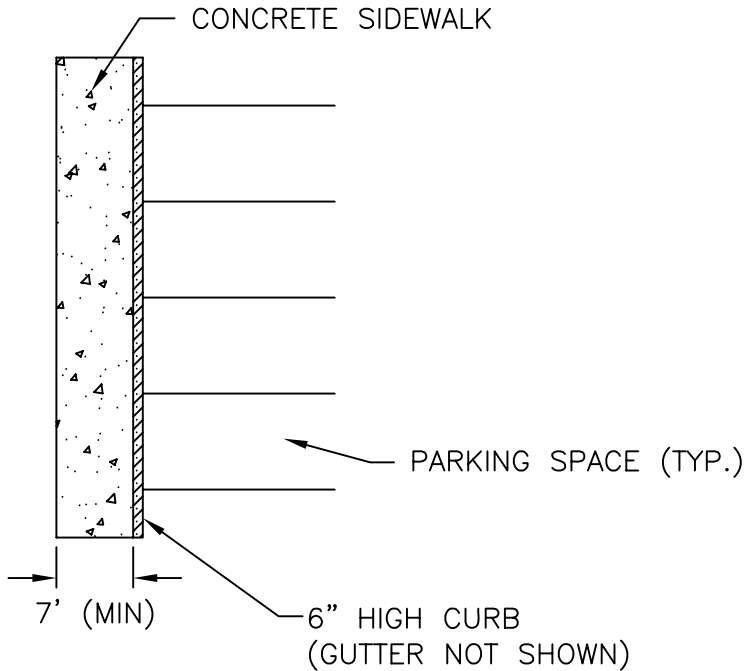

SIDEWALK BETWEEN TWO ROWS OF HEAD-IN OR BACK-IN PARKING SHALL BE AT LEAST 9 FEET WIDE.

PARKING ON BOTH SIDES OF A SIDEWALK

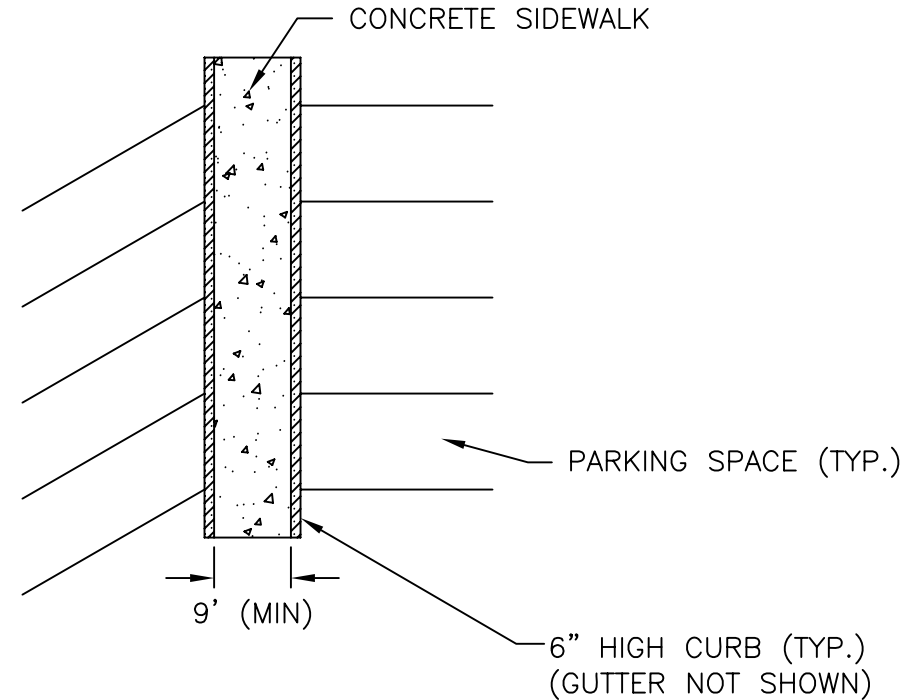

NOTES:

1. A 2-FOOT-WIDE PLANTING STRIP LOCATED AT THE BACK OF CURB CAN BE USED IN LIEU OF 2 FEET OF SIDEWALK WIDTH.
2. PARKING AT ANY ANGLE OTHER THAN PARALLEL SHALL BE SUBJECT TO THIS STANDARD.
3. IF MONOLITHIC CURB & SIDEWALK IS USED, ADD 6" TO ALL DIMENSIONS (1' IF PARKING ON BOTH SIDES).
4. WHEELSTOPS SHALL ONLY BE USED IN LIEU OF 2 FEET OF SIDEWALK WITH THE APPROVAL OF THE CITY AND WHEN EXISTING CONDITIONS PREVENT CONSTRUCTION OF A 7-FOOT/9-FOOT SIDEWALK. WHEELSTOPS SHALL BE 6" HIGH, MADE OUT OF 3600-PSI REINFORCED CONCRETE, AND ANCHORED WITH #5 OR GREATER REBAR (2' MINIMUM LENGTH). REBAR HOLES SHALL BE GROUTED UPON INSTALLATION. WHEELSTOPS SHALL BE PLACED AT 2 FEET FROM THE EDGE OF SIDEWALK OR OBSTRUCTION.

NOT TO SCALE



CITY OF CHARLOTTE
LAND DEVELOPMENT STANDARDS
INCLUDES CHARLOTTE ETJ

PARKING STANDARDS (CONTINUED)

STD. NO.	REV.
50.09B	1

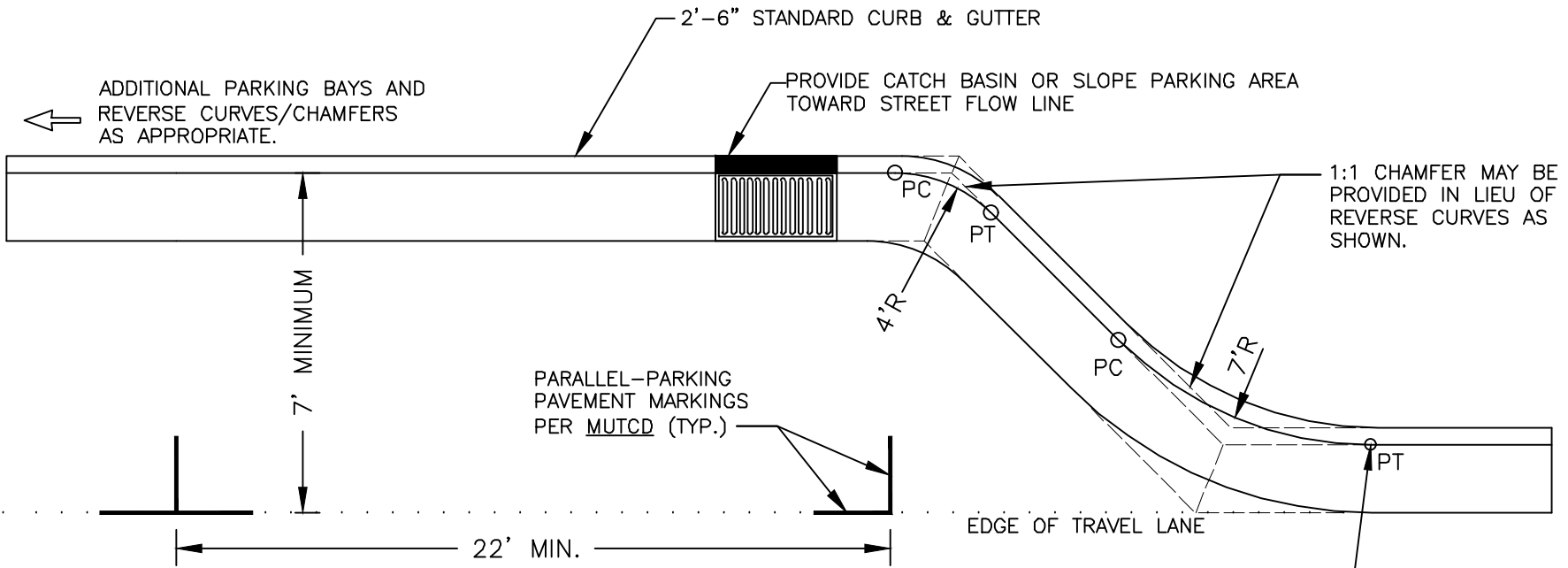

NOTES:

1. REVERSE CURVES/CHAMFERS NOT NECESSARY IF ADEQUATE DRAINAGE CAN BE PROVIDED THAT WILL ENSURE THAT SEDIMENT, WATER, DEBRIS, ETC., DOES NOT COLLECT IN 90-DEGREE CORNERS.
2. PARALLEL ACCESSIBLE SPACES AND LOADING ZONES TO BE REVIEWED BY CDOT ON A CASE-BY-CASE BASIS.
3. FOR PARKING BAYS THAT ARE 8 FEET IN WIDTH OR GREATER, THE PAVEMENT MARKINGS SHALL BE SET AT ONE (1) FOOT LESS THAN THE STALL WIDTH.
4. GREATER SEPARATION FROM INTERVENING STREETS THAN THE DISTANCES PROVIDED IN THE MATRIX MAY BE REQUIRED AT CDOT'S DISCRETION.
5. POSITIVE DRAINAGE SHALL BE PROVIDED EITHER BY INSTALLATION OF APPROPRIATE DRAINAGE STRUCTURES OR SLOPE PARKING AREA TO STREET FLOW LINE. SLOPING PARKING AREA TO STREET FLOW LINE ONLY PERMITTED IF ROAD GRADE IS GREATER THAN 2%.
6. IF A BIKE LANE IS REQUIRED ADJACENT TO PARALLEL PARKING, A 3' BUFFER IS REQUIRED BETWEEN PARKING AND THE BIKE LANE.

MEASURE DISTANCE TO NEXT INTERVENING STREET OR ACCESSIBLE RAMP FROM THIS POINT. (SEE MATRIX BELOW)

PARALLEL PARKING BAY LOCATED ON

MINIMUM DISTANCE TO NEXT INTERVENING STREET

	DRIVEWAY	LOCAL/ COLLECTOR	ARTERIAL/ UPTOWN STREET
LOCAL/COLLECTOR	20'	20'	20'
ARTERIAL/UPTOWN STREET	20'	20'	50'

NOT TO SCALE



CITY OF CHARLOTTE
LAND DEVELOPMENT STANDARDS
INCLUDES CHARLOTTE ETJ

PARALLEL PARKING STANDARDS

STD. NO.	REV.
50.09C	23

NOTES:

1. AN ACCESS AISLE SHALL BE PROVIDED AT STREET LEVEL FOR ON-STREET PARALLEL PARKING WITH 5' MIN. WIDTH AND SHALL EXTEND THE FULL LENGTH OF THE PARKING SPACE.
2. ACCESSIBLE SPACE AND ACCESS AISLE SHALL BE OBSTRUCTION-FREE (INCLUDING ADJACENT SIDEWALK OR SHARED USE PATH).
3. ALL CONCRETE TO BE 3600 P.S.I.
4. SEE STD NO 10.18 FOR DETAIL OF 18" VERTICAL CURB.
5. SEE STD. NO 10.17C FOR DETAIL OF EXPANSION JOINT AND GROOVE JOINT.
6. SEE STD. NO 10.22 FOR SIDEWALK DETAIL.
7. GUTTER FLOW LINE SHALL BE MAINTAINED THROUGH THE ACCESS AISLE.
8. ACCESSIBLE PAVEMENT MARKING DETAIL:
 - INSTALL INTERNATIONAL SYMBOL OF ACCESSIBILITY PARKING SPACE MARKINGS, INCLUDING WHITE SYMBOL WITH BLUE BACKGROUND AND WHITE BORDER. SYMBOL SHALL HAVE MIN. HEIGHT OF 28 INCHES AND MIN. WIDTH OF 24 INCHES (EXCLUSIVE OF BLUE BACKGROUND AND WHITE BORDER). STROKE WIDTH SHALL BE MIN. 3 INCHES.
 - WHITE PAVEMENT MARKINGS PLACED ON CONCRETE SHALL BE SHADOWED WITH BLACK BORDER.
 - TYPICAL SYMBOL LOCATION AND ORIENTATION PER "DIAGRAM A" BELOW
8. PROPOSED TREES MUST BE PLANTED 6-8' AWAY FROM THE BACK OF ACCESS AISLE CURB.
9. SPECIFY STD. NO. 40.11, "BRIDGING TREE ROOTS" IF ENCROACHING ON GROWING SPACE OF TREE.
10. LOCATE IN MOST LEVEL AREA OF BLOCK (RECOMMENDED PRACTICE) TO MAXIMIZE USABILITY.
11. CURB LINE SHIFTS TOWARD RIGHT-OF-WAY TO ACCOMMODATE ACCESS AISLE.
12. SPACE AND ACCESS AISLE SHOULD HAVE SMOOTH SURFACE FOR LIFT DEPLOYMENT. MINIMIZE CROSS SLOPE FOR LIFT OPERATION.
13. PARKING METER FOR ACCESSIBLE SPACE - PROVIDE A CLEAR APPROACH AREA WHERE PARKING METERS ARE REQUIRED. COORDINATE WITH CDOT FOR METER LOCATIONS.
14. FOR MORE INFORMATION SEE SECTION R310 OF "PROPOSED GUIDELINES FOR PEDESTRIAN FACILITIES IN THE PUBLIC RIGHT-OF-WAY ACCESSIBILITY GUIDELINES" (PROWAG).
15. USE SIGN "C" AS SHOWN ON STD. 50.10A FOR ON-STREET PARKING.
16. ON-STREET ACCESSIBLE PARKING DOES NOT COUNT TOWARDS ON-SITE ACCESSIBLE PARKING REQUIREMENTS.

ON-STREET PARKING SPACES REQUIRED

TOTAL NUMBER OF MARKED OR METERED PARKING SPACES ON THE BLOCK PERIMETER	MINIMUM REQUIRED NUMBER OF ACCESSIBLE PARKING SPACES
1 TO 25	1
26 TO 50	2
51 TO 75	3
76 TO 100	4
101 TO 150	5
151 TO 200	6
201 AND OVER	4% OF TOTAL

(BASED ON TABLE R211 OF PROWAG)

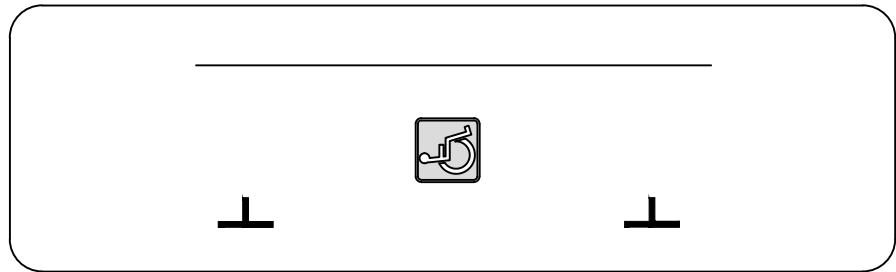

DIAGRAM A



**CITY OF CHARLOTTE
LAND DEVELOPMENT STANDARDS
INCLUDES CHARLOTTE ETJ**

**ACCESSIBLE ON-STREET
PARALLEL PARKING**

STD. NO.	REV.
50.09D	25

ACCESSIBLE PARKING REQUIREMENTS

TOTAL PARKING SPACES PROVIDED	MINIMUM NUMBER OF ACCESSIBLE SPACES REQUIRED	MINIMUM NUMBER OF ACCESSIBLE SPACES REQUIRED TO BE VAN ACCESSIBLE
1 TO 25	1	1
26 TO 50	2	1
51 TO 75	3	1
76 TO 100	4	1
101 TO 150	5	1
151 TO 200	6	1
201 TO 300	7	2
301 TO 400	8	2
401 TO 500	9	2
501 TO 1000	2% OF TOTAL	1 IN EVERY 6 ACCESSIBLE SPACES
1001 AND OVER	20 PLUS 1 FOR EACH 100 OVER 1000	1 IN EVERY 6 ACCESSIBLE SPACES

REFERENCE: SECTION 1106 OF NC BUILDING CODE

NOTES:

- ALL ACCESSIBLE SIGNS (R7-8P, R7-8, R7-1, AND 50.10C) SHALL BE MOUNTED AT 7 FEET FROM GRADE TO BOTTOM EDGE OF SIGN FACE (PER MUTCD). MOUNTING HEIGHT CAN BE REDUCED TO 5 FEET IF PLACED IN AN AREA BETWEEN SIDEWALK AND BUILDING FACE IN WHICH PEDESTRIANS ARE NOT EXPECTED TO USE.
- IF ACCESSIBLE ROUTE IS A RAISED SIDEWALK AREA, THEN RAMPS ARE REQUIRED AT LOADING ZONE AREA. MAINTAIN MIN. 4' WIDE CONTINUOUS PASSAGE.
- VERTICAL CLEARANCE FOR VANS MUST BE GREATER THAN 98-INCHES.
- THIS DETAIL IS TO PROVIDE GENERAL GUIDANCE FOR PARKING LAYOUT AND DESIGN; REFER TO MANUAL ON UNIFORM TRAFFIC CONTROL DEVICES (MUTCD) U.S. DEPARTMENT OF TRANSPORTATION AND NORTH CAROLINA DEPARTMENT OF TRANSPORTATION SUPPLEMENT AND NC BUILDING CODE FOR ADDITIONAL INFORMATION.
- ON-STREET ACCESSIBLE PARKING DOES NOT COUNT TOWARD ON-SITE ACCESSIBLE PARKING REQUIREMENTS.

PARKING SPACE PAVEMENT MARKINGS

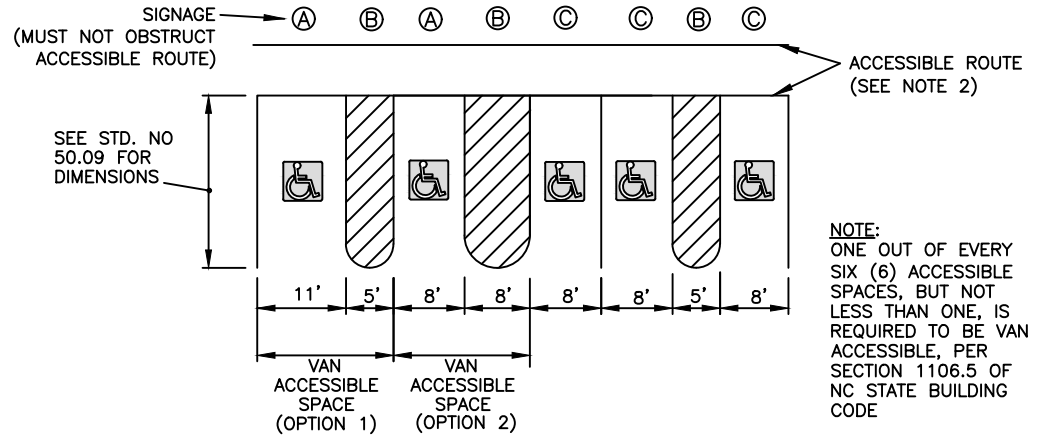

NOTE:
ONE OUT OF EVERY SIX (6) ACCESSIBLE SPACES, BUT NOT LESS THAN ONE, IS REQUIRED TO BE VAN ACCESSIBLE, PER SECTION 1106.5 OF NC STATE BUILDING CODE

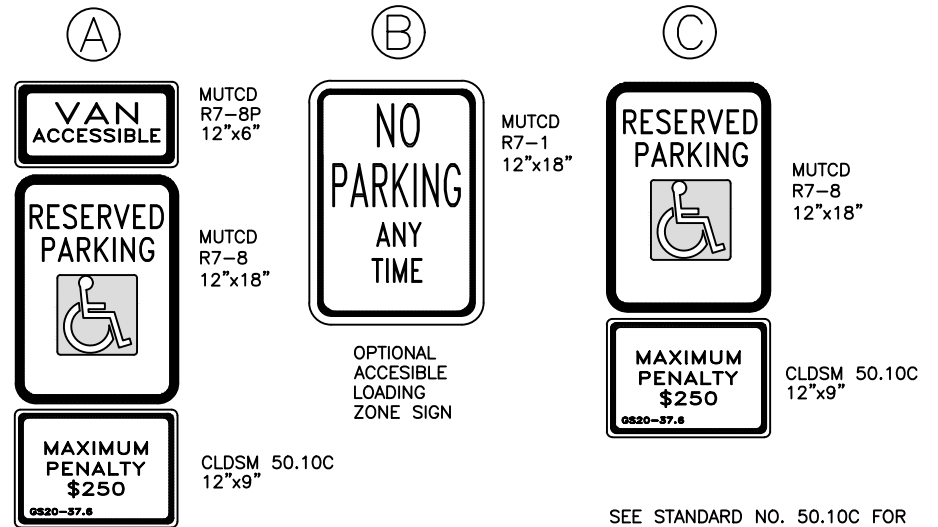

SEE STANDARD NO. 50.10C FOR SUPPLEMENTAL SIGN DETAIL

NOT TO SCALE



CITY OF CHARLOTTE
LAND DEVELOPMENT STANDARDS
INCLUDES CHARLOTTE ETJ

ACCESSIBLE PARKING AND SIGNAGE STANDARDS

STD. NO.	REV.
50.10A	23

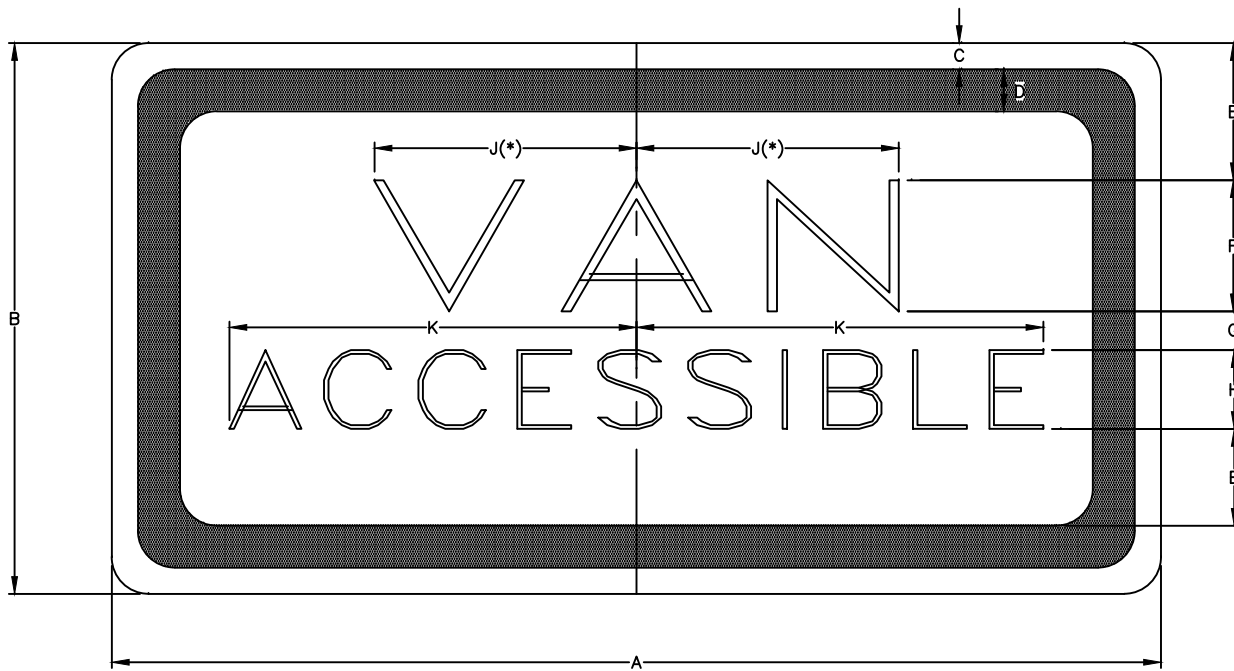

R7-8P

DIMENSIONS (INCHES)										
A	B	C	D	E	F	G	H	J	K	L
12	6	3/8	3/8	1-1/2	1-1/2D	1/2	1D	2-1/2	4	1-1/2

* INCREASE SPACING 50%
 D-FHWA (FEDERAL HIGHWAY ADMINISTRATION/USDOT)
 SERIES D LETTERS

LEGEND AND BORDER - GREEN
 BACKGROUND - WHITE

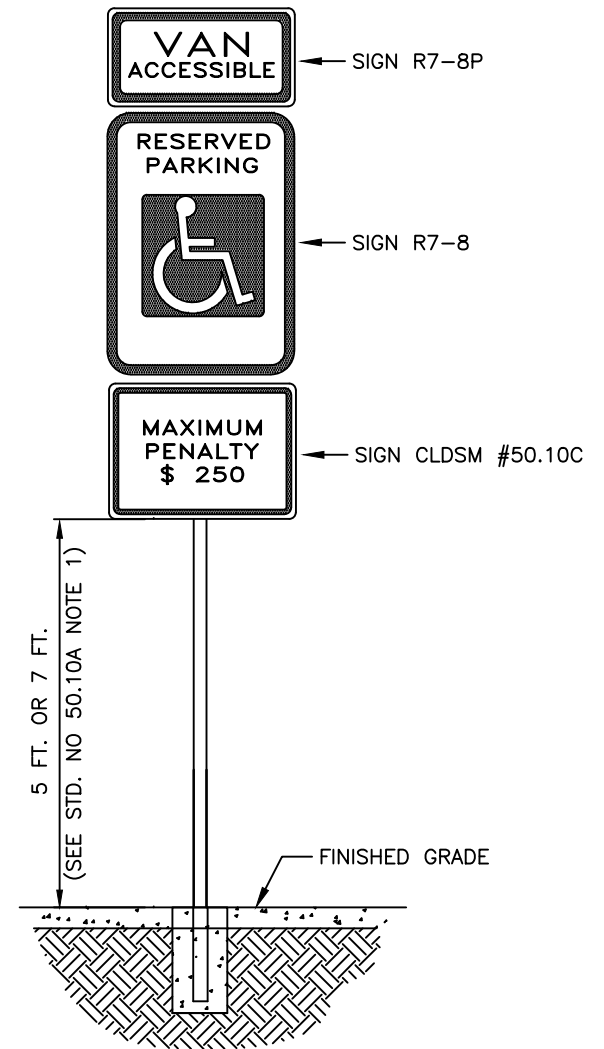

NOT TO SCALE



CITY OF CHARLOTTE
 LAND DEVELOPMENT STANDARDS
 INCLUDES CHARLOTTE ETJ

SUPPLEMENTAL VAN ACCESSIBLE
 SIGN (R7-8P)

STD. NO.	REV.
50.10B	18

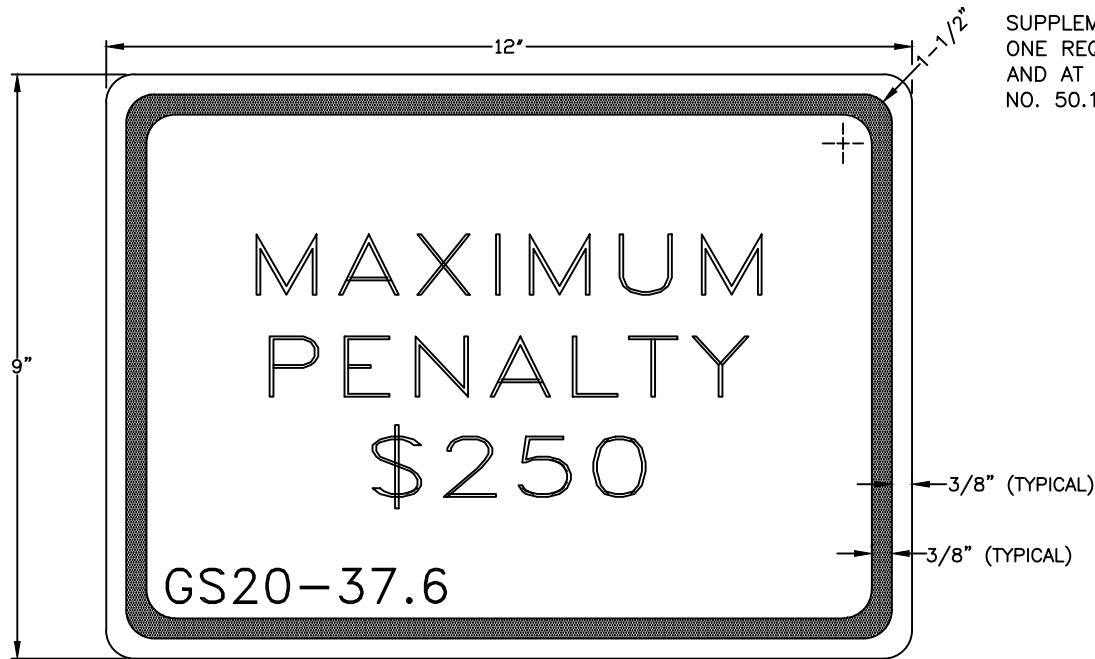

LEGEND AND BORDER - GREEN
BACKGROUND - WHITE

SIGN APPROVED FOR USE UNDER GENERAL STATUTE 20-37.6

THIS PENALTY SIGN IS REQUIRED TO ACCOMPANY ALL R7-8
PARKING SIGNS ERECTED AFTER DECEMBER 31,1990

NOTE:

SUPPLEMENTAL VAN ACCESSIBLE SIGN (R7-8P) USED IF THERE IS ONLY ONE REQUIRED ACCESSIBLE PARKING SPACE (MUST BE VAN ACCESSIBLE) AND AT EACH ADDITIONAL REQUIRED VAN ACCESSIBLE SPACE. (SEE STD. NO. 50.10B)

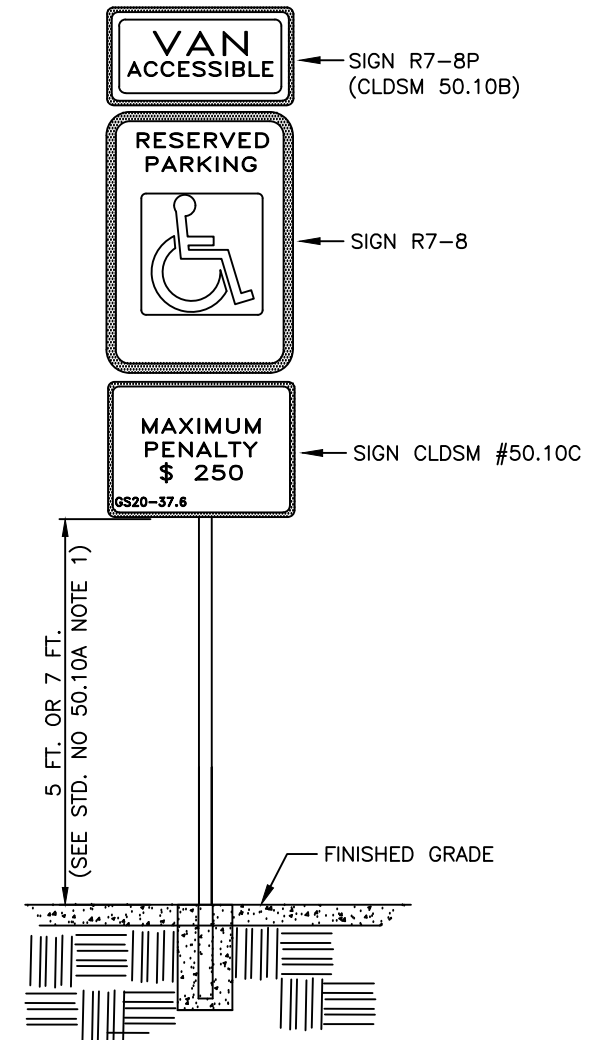

NOT TO SCALE



CITY OF CHARLOTTE
LAND DEVELOPMENT STANDARDS
INCLUDES CHARLOTTE ETJ

SUPPLEMENTAL ACCESSIBLE
SIGN

STD. NO.	REV.
50.10C	18

NOTES:

1. PAVEMENT MARKINGS TO BE PER LATEST EDITION OF THE MANUAL ON UNIFORM TRAFFIC CONTROL DEVICES (MUTCD).
2. SIGNS TO BE LOCATED/SPACED PER MUTCD REQUIREMENTS.
3. "CIRCULAR INTERSECTION" AND "TRAFFIC CIRCLE" SUBPLATE SIGNS, AND YELLOW TUBULAR MARKERS, ARE REQUIRED ON THOROUGHFARES. CDOT WILL DETERMINE IF ONE OR MORE OF THESE ARE NECESSARY ON LOCAL OR COLLECTOR STREETS.
4. "PEDESTRIAN CROSSING" AND ARROW SUBPLATE SIGNS ARE REQUIRED WHEREVER THERE IS A MARKED CROSSWALK OR ON A THOROUGHFARE.
5. "YIELD" SIGNS ARE ALWAYS REQUIRED.
6. PAVEMENT MARKINGS, SPLITTER ISLAND DESIGNS, CROSSWALK, ETC., ARE SHOWN FOR CONTEXT ONLY. REFER TO THE MUTCD AND/OR THE FEDERAL HIGHWAY ADMINISTRATION'S MANUAL ROUNDABOUTS: AN INFORMATIONAL GUIDE FOR MORE DETAIL OR DESIGN INFORMATION.
7. ADDITIONAL SIGNS MAY BE NEEDED ON A CASE-BY-CASE BASIS, TO BE EVALUATED BY CDOT.
8. ALL PAVEMENT MARKING SHALL BE THERMOPLASTIC.

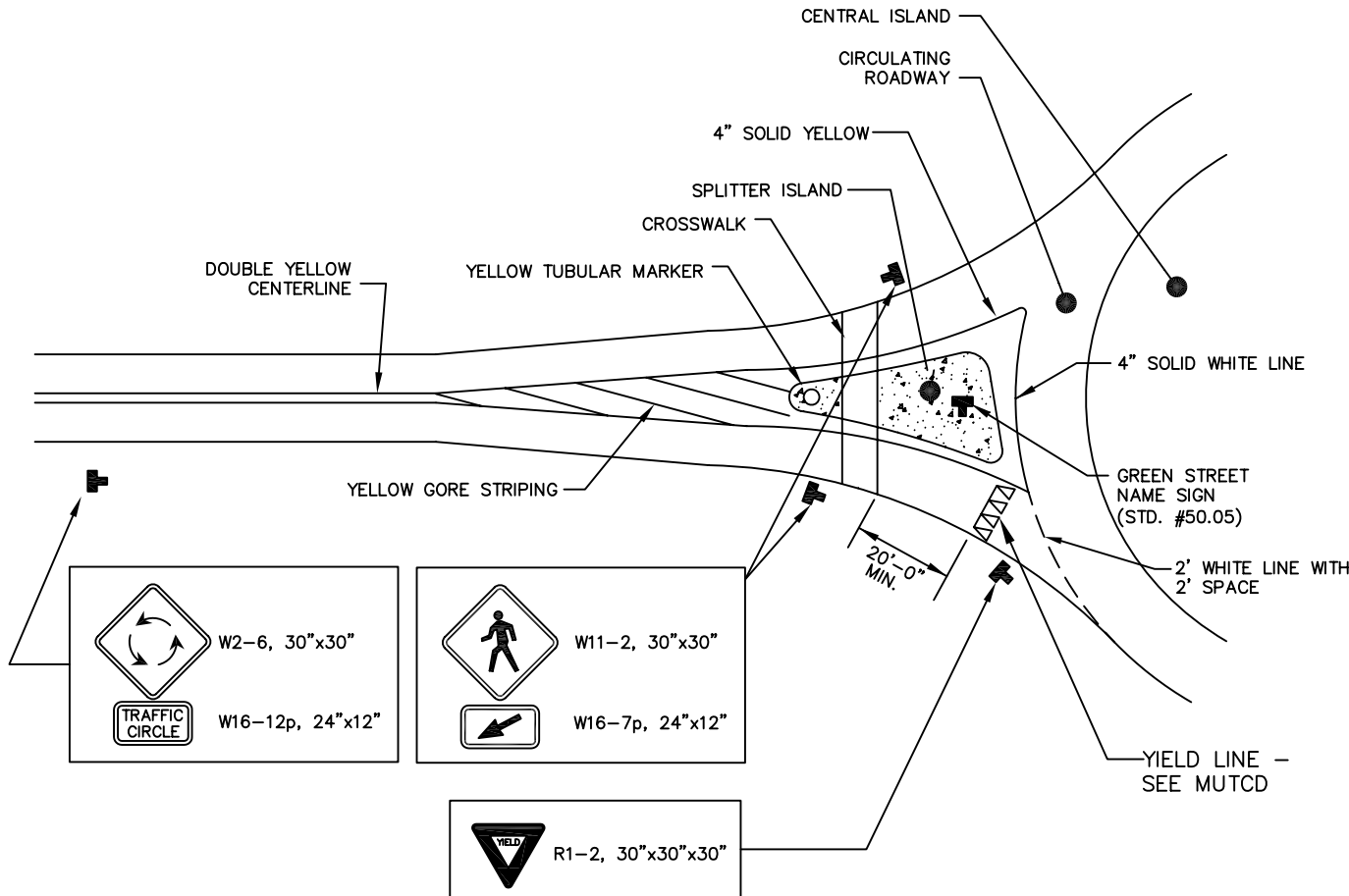

NOT TO SCALE



**CITY OF CHARLOTTE
LAND DEVELOPMENT STANDARDS**
INCLUDES CHARLOTTE ETJ

**SIGNAGE AND PAVEMENT MARKINGS
AT ROUNDABOUTS**

STD. NO.	REV.
50.11	1

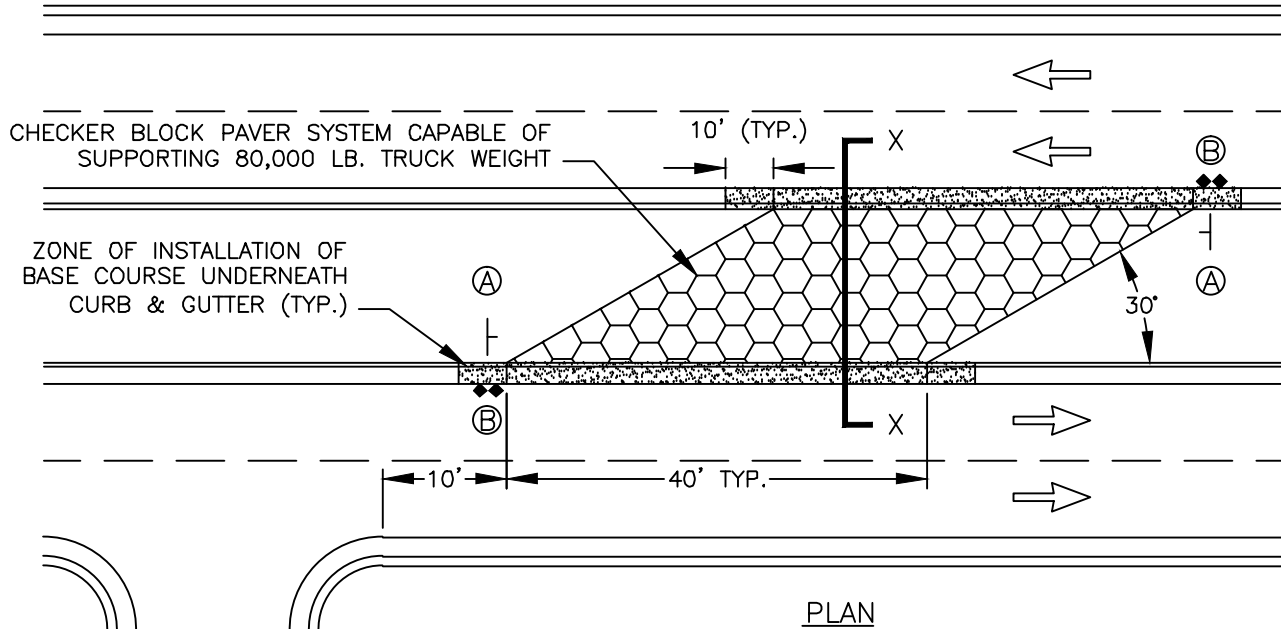

- Ⓐ "NO LEFT TURN" (R3-2, 24"x24")
- Ⓑ YELLOW/YELLOW RAISED PVMT. MARKER 1' O.C. SEE NCDOT STD. #1250.01.

NOTES:

1. CROSSOVER TO BE OFFSET 10' FROM ANY INTERSECTING STREET OR DRIVEWAY OTHER THAN A FIRE DEPARTMENT DRIVEWAY.
2. ASPHALT BASE COURSE UNDERNEATH MOUNTABLE CURB AND GUTTER SHALL EXTEND AT LEAST 10 FEET BEYOND CROSSOVER.
3. ONLY FOR USE AT RIGHT-IN/RIGHT-OUT (RI/RO) ENTRANCES TO RESIDENTIAL SUBDIVISIONS AND COMMERCIAL DEVELOPMENTS WITH PRIOR APPROVAL FROM CHARLOTTE DEPARTMENT OF TRANSPORTATION (CDOT).
4. INCLUDE SUBDRAIN AS NECESSARY PER CLDSM 20.28.

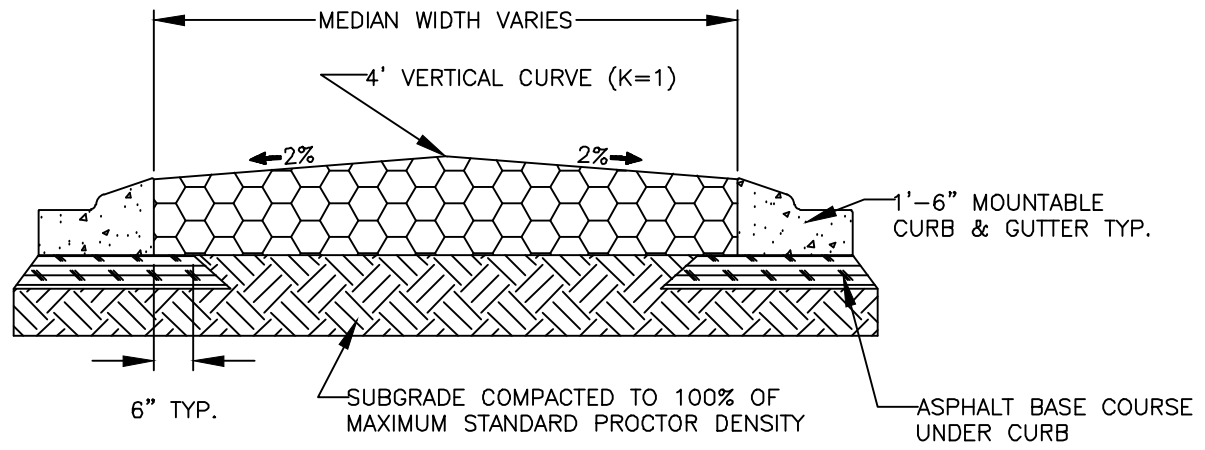

CROSS-SECTION X-X

NOT TO SCALE



CITY OF CHARLOTTE
 LAND DEVELOPMENT STANDARDS
 INCLUDES CHARLOTTE ETJ

EMERGENCY VEHICLE
 MEDIAN CROSSOVER

STD. NO.	REV.
50.12	13

RAISED MONOLITHIC CONCRETE MEDIAN
(SEE NCDOT STD. DWG. #852.01)

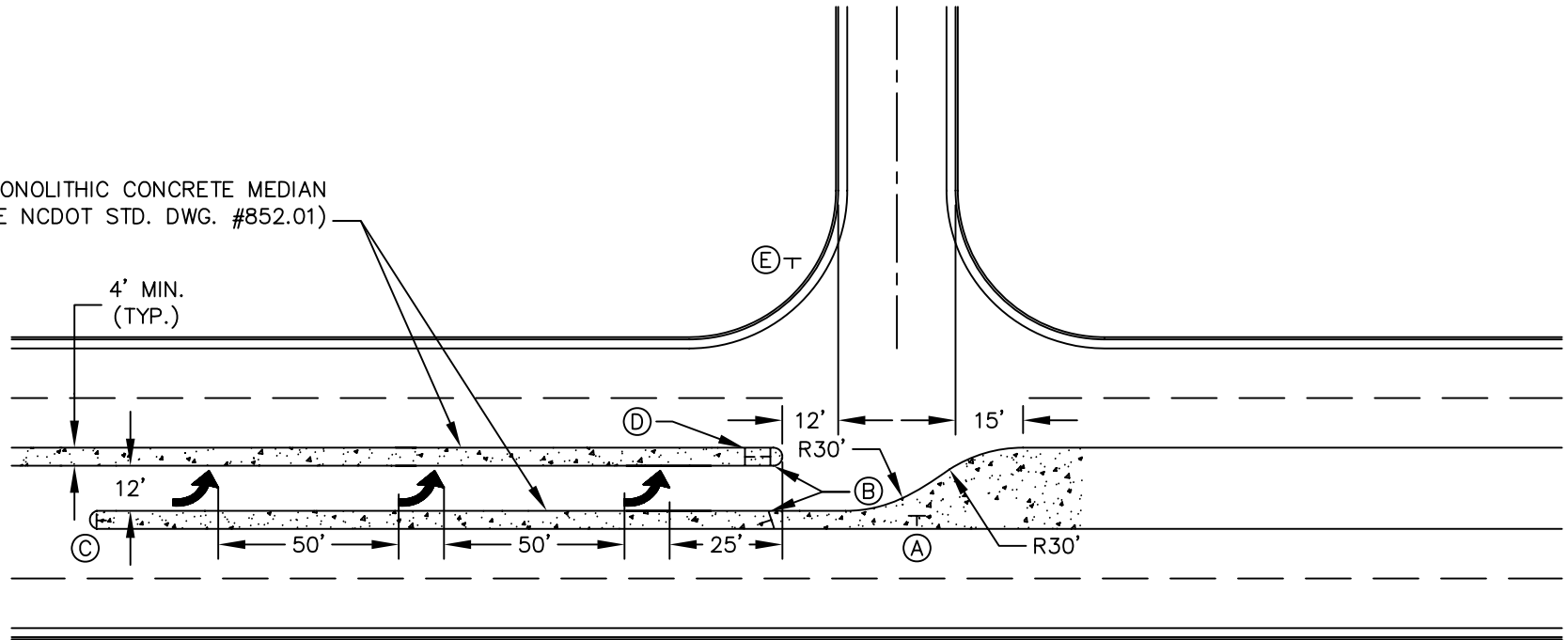

NOTES:

SIGN LEGEND

- (A) ONE WAY (R6-2R, 18"x24")
- (B) DO NOT ENTER (R5-1, 30"x30")
- (C) DOUBLE-DOWN ARROW (W12-1, 30"x30")
- (D) NO U-TURN (R3-4, 24"x24")*
- (E) STOP (R1-1, 30"x30")

* IF NECESSARY

1. ADDITIONAL PAVEMENT MARKINGS (EDGE LINES, GORES, ETC.) ARE NOT SHOWN BUT ARE REQUIRED. SEE CDOT PAVEMENT MARKING STANDARDS.
2. FOR DIVIDED SIDE STREETS, MEASURE THE 12 FOOT DIMENSION FROM THE FACE OF MEDIAN INSTEAD OF FACE OF CURB ON APPROACHING LANE.
3. ALL SIGNS SHALL BE MUTCD STANDARD SIGNS.

NOT TO SCALE



CITY OF CHARLOTTE
LAND DEVELOPMENT STANDARDS
INCLUDES CHARLOTTE ETJ

DIRECTIONAL CROSSOVER
WITH RAISED MEDIANS

STD. NO.	REV.
50.13	

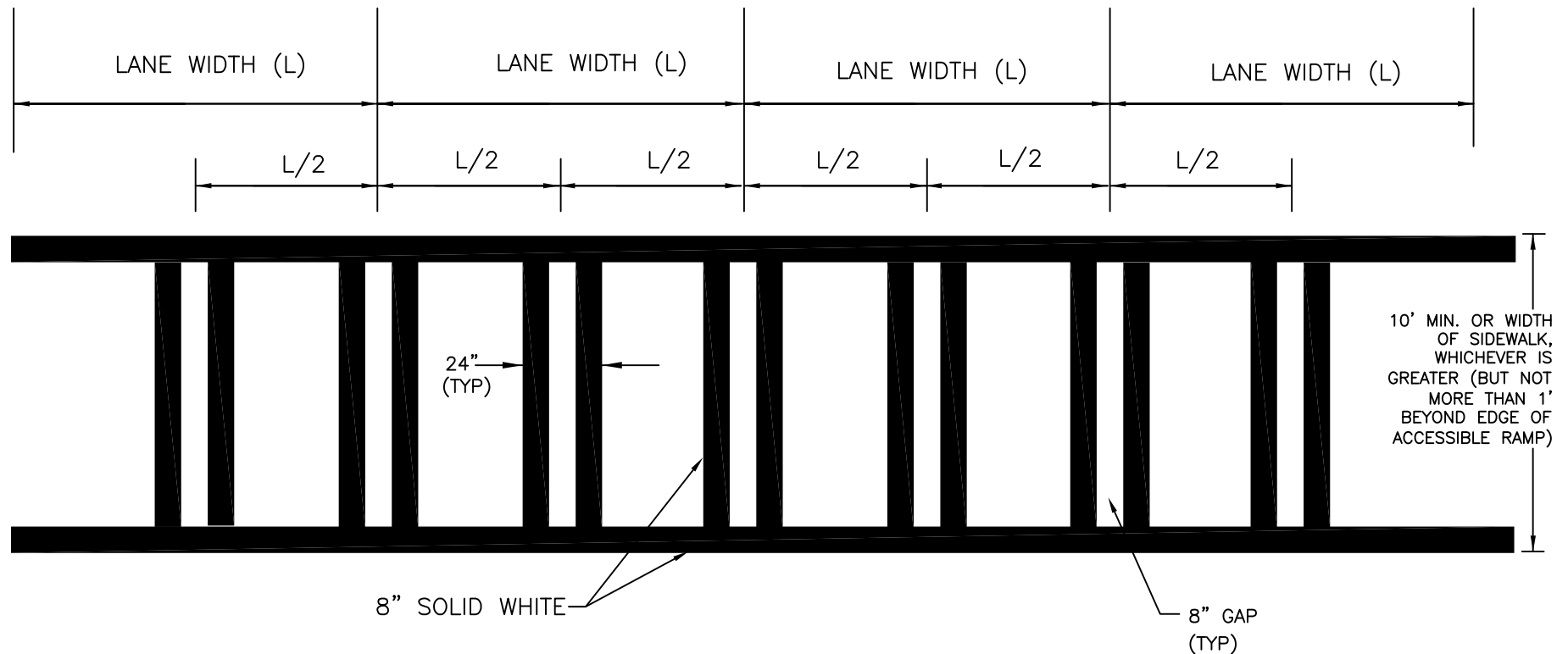

NOTES:

1. PER MUTCD STANDARDS, WHEN CROSSWALK LINES ARE USED THEY SHALL CONSIST OF SOLID WHITE LINES THAT MARK THE CROSSWALK. THEY SHALL BE NOT LESS THAN 150 MM (6 IN) NOR GREATER THAN 600 MM (24 IN) IN WIDTH.
2. IF TRANSVERSE LINES ARE USED TO MARK A CROSSWALK, THE GAP BETWEEN THE LINES SHOULD NOT BE LESS THAN 1.8 M (6 FT). IF DIAGONAL OR LONGITUDINAL LINES ARE USED WITHOUT TRANSVERSE LINES TO MARK A CROSSWALK, THE CROSSWALK SHOULD NOT BE LESS THAN 1.8 M (6 FT) WIDE.
3. IF USED, THE DIAGONAL OR LONGITUDINAL LINES SHOULD BE 300 TO 600 MM (12 TO 24 IN) WIDE AND SPACED 300 TO 1500 MM (12 TO 60 IN) APART. THE MARKING DESIGN SHOULD AVOID THE WHEEL PATHS, AND THE SPACING SHOULD NOT EXCEED 2.5 TIMES THE LINE WIDTH.



CITY OF CHARLOTTE
LAND DEVELOPMENT STANDARDS
 INCLUDES CHARLOTTE ETJ

PIANO-STYLE CROSSWALK

STD. NO.	REV.
50.14	9

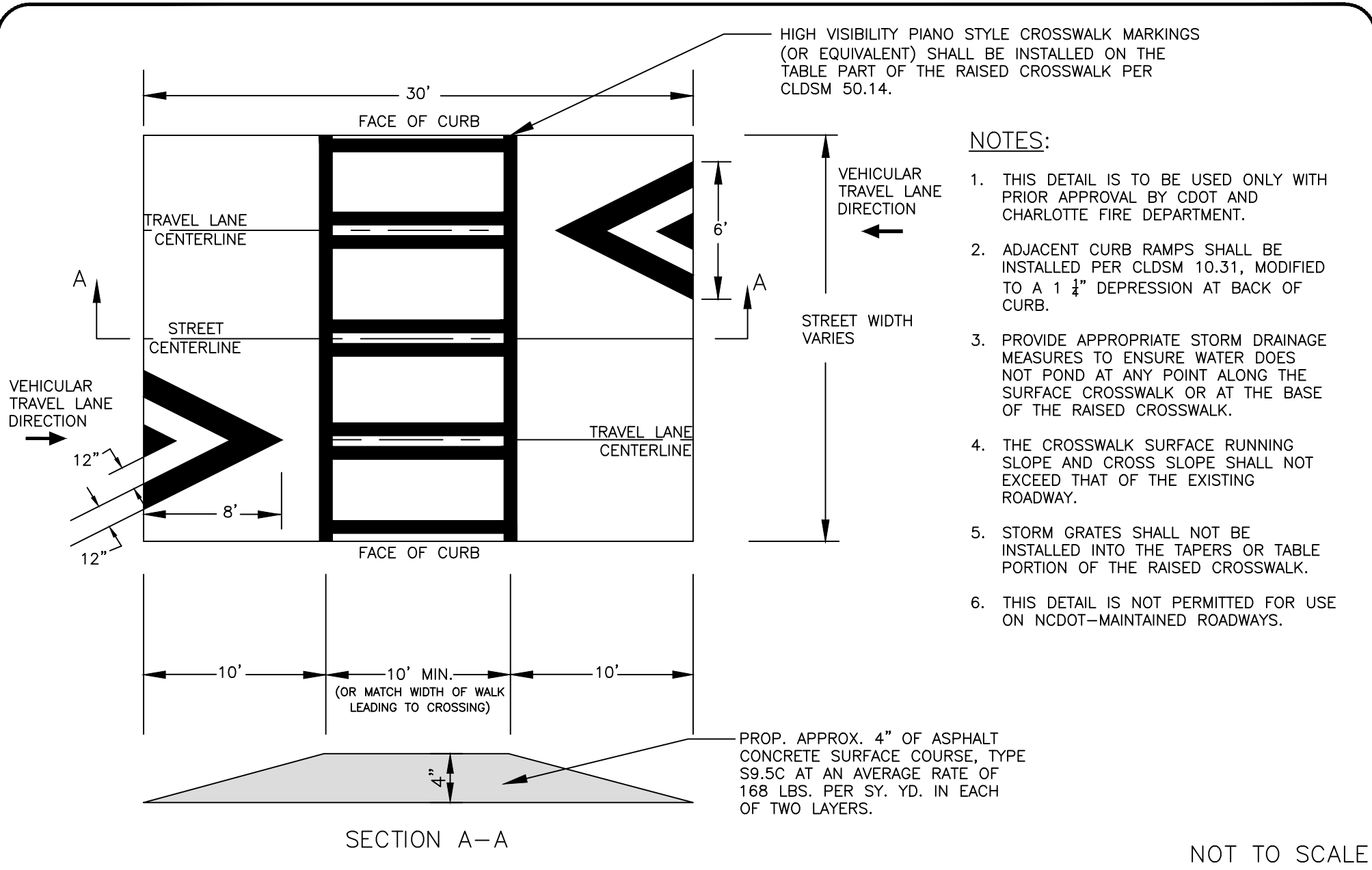

CITY OF CHARLOTTE
LAND DEVELOPMENT STANDARDS

RAISED CROSSWALK

STD. NO.	REV.
50.15	23

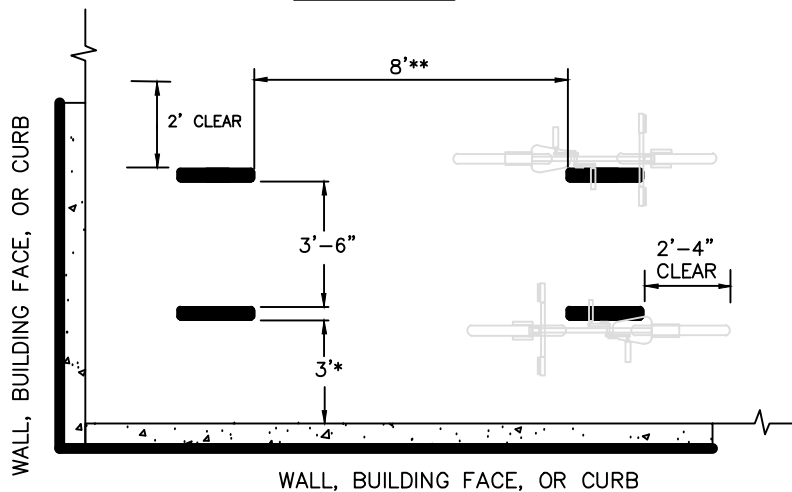
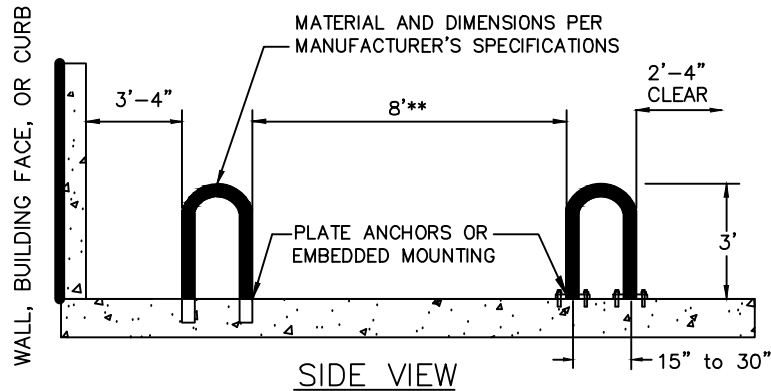

PLAN VIEW

* 5' MINIMUM SEPARATION FROM CURB FACE WHEN INSTALLED ADJACENT TO A CURB WITH "HEAD-IN" AUTOMOBILE PARKING

** MEASURED FROM NEAREST VERTICAL COMPONENT OF NEIGHBORING RACK

NOTES:

1. BIKE RACK GENERAL REQUIREMENTS:
 - SHOULD SUPPORT THE BICYCLE UPRIGHT WITHOUT PUTTING STRESS ON THE WHEELS
 - SHOULD ACCOMMODATE A VARIETY OF BICYCLES AND ATTACHMENTS
 - SHOULD ALLOW LOCKING OF FRAME AND AT LEAST ONE WHEEL WITH U-LOCK
 - SHOULD PROVIDE SECURITY AND LONGEVITY FEATURES APPROPRIATE FOR THE INTENDED LOCATION
 - SHOULD BE INTUITIVE
2. BIKE RACKS SHOULD BE INSTALLED PER MANUFACTURER'S RECOMMENDED INSTALLATION PROCEDURES.
3. ALTERNATIVE BIKE RACKS OR LOCKERS MAY BE USED BUT ARE SUBJECT TO APPROVAL OF THE CHARLOTTE DEPT. OF TRANSPORTATION.
4. ALL DIMENSIONS SHOWN ARE MINIMUM.
5. RACK MUST BE CANE DETECTABLE. RACK AND CLEARANCES SHOWN ARE TO BE OUTSIDE THE PEDESTRIAN ACCESSIBLE ROUTE.

TYPICAL MOUNT OPTIONS:

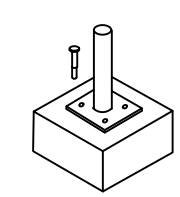

SURFACE
PLATE BASE WITH ANCHORS
(NOT PERMITTED IN
PAVER BRICK SURFACE)

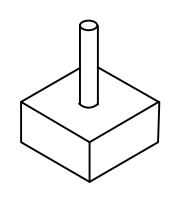

IN-GROUND
EMBED INTO
CONCRETE BASE

NOT TO SCALE



CITY OF CHARLOTTE
LAND DEVELOPMENT STANDARDS
INCLUDES CHARLOTTE ETJ

INVERTED "U" RACK FOR
BICYCLE PARKING

STD. NO.	REV.
50.20	15

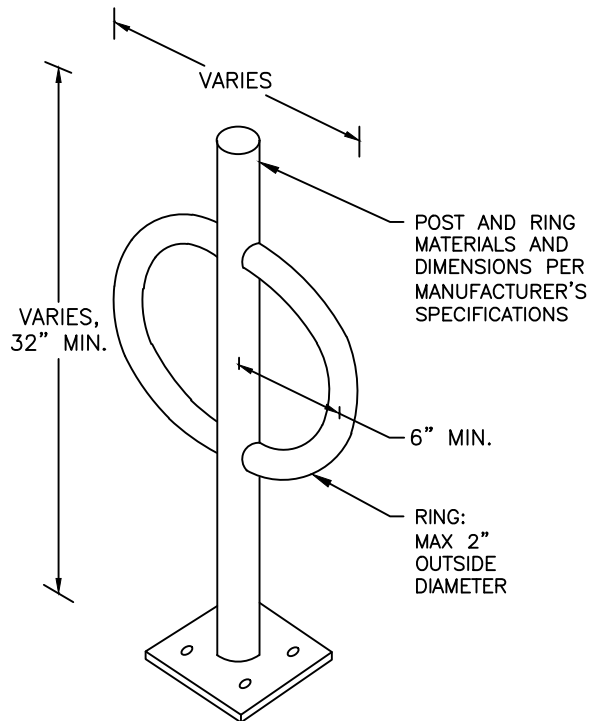

TYPICAL MOUNT OPTIONS:

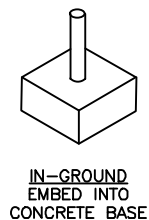
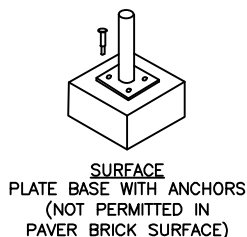

NOTES:

1. BIKE RACK GENERAL REQUIREMENTS:
 - SHOULD SUPPORT THE BICYCLE UPRIGHT WITHOUT PUTTING STRESS ON THE WHEELS
 - SHOULD ACCOMODATE A VARIETY OF BICYCLES AND ATTACHMENTS
 - SHOULD ALLOW LOCKING OF FRAME AND AT LEAST ONE WHEEL WITH U-LOCK
 - SHOULD PROVIDE SECURITY AND LONGEVITY FEATURES APPROPRIATE FOR THE INTENDED LOCATION
 - SHOULD BE INTUITIVE
2. BIKE RACKS SHOULD BE INSTALLED PER MANUFACTURER'S RECOMMENDED INSTALLATION PROCEDURES.
3. ALTERNATIVE BIKE RACKS OR LOCKERS MAY BE USED BUT ARE SUBJECT TO APPROVAL OF THE CHARLOTTE DEPT. OF TRANSPORTATION.
4. ALL DIMENSIONS SHOWN ARE MINIMUM.
5. RACK MUST BE CANE DETECTABLE. RACK AND CLEARANCES SHOWN ARE TO BE OUTSIDE THE PEDESTRIAN ACCESSIBLE ROUTE.

INSTALLATION PLAN VIEW:

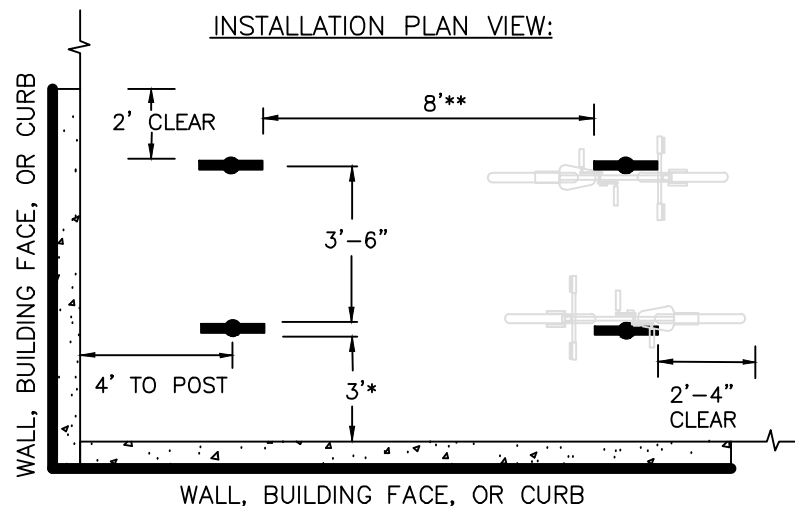

* 5' MINIMUM SEPARATION FROM CURB FACE WHEN INSTALLED ADJACENT TO A CURB WITH "HEAD-IN" AUTOMOBILE PARKING

** MEASURED FROM NEAREST VERTICAL COMPONENT OF NEIGHBORING RACK



CITY OF CHARLOTTE
LAND DEVELOPMENT STANDARDS
 INCLUDES CHARLOTTE ETJ

POST AND RING BIKE RACK

STD. NO.	REV.
50.21	15

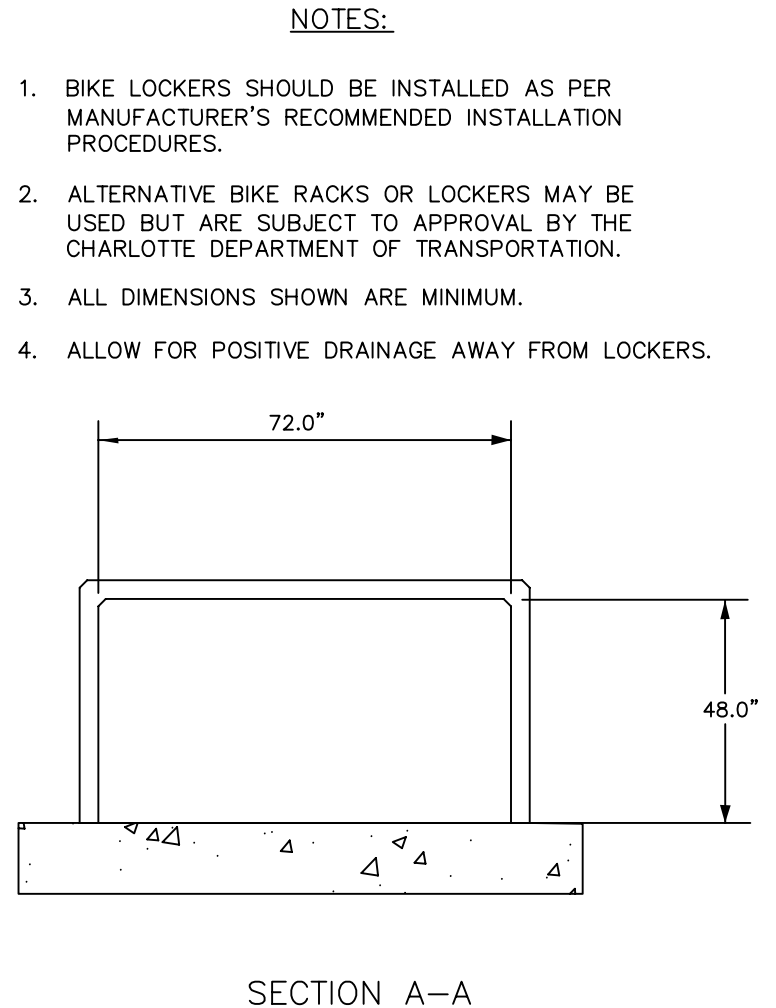
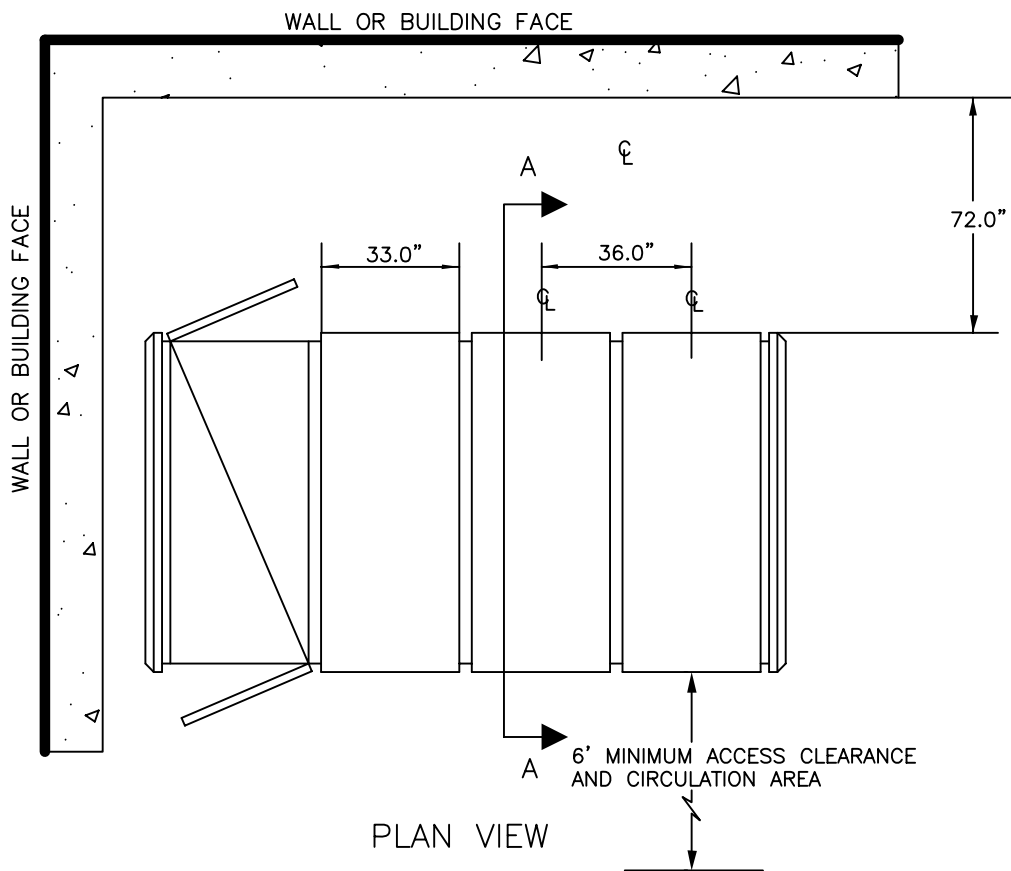

NOT TO SCALE



CITY OF CHARLOTTE
 LAND DEVELOPMENT STANDARDS
 INCLUDES CHARLOTTE ETJ

BICYCLE LOCKERS

STD. NO.	REV.
50.22	

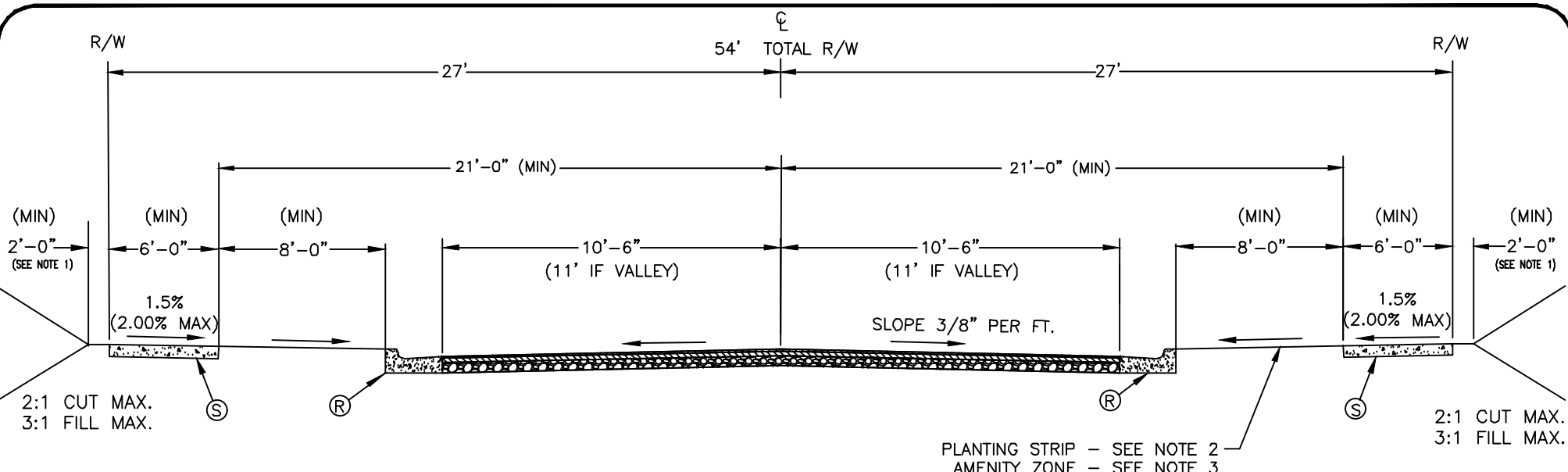

PLANTING STRIP - SEE NOTE 2
 AMENITY ZONE - SEE NOTE 3

SURFACE COURSE

1" S9.5B

FINAL LIFT TO BE APPLIED UPON MEETING ONE OF THE FOLLOWING CONDITIONS:

- 1) 75% DEVELOPMENT OCCUPANCY,
- 2) 1 YEAR FROM INTERMEDIATE COURSE PLACEMENT,
- 3) FOR ETJ STREETS, FINAL 1" MAY BE PLACED WHEN APPROVED BY NCDOT.

INTERMEDIATE COURSE

1 1/2" S9.5C OR S9.5B

BASE COURSE

8" COMPACTED AGGREGATE BASE COURSE, OR 4" BCBC TYPE B25.0C. SHOULD ENTIRE DEVELOPMENT HAVE A CBR OF 6 OR GREATER, THEN AN ALTERNATIVE BASE COURSE PAVEMENT DESIGN MAY BE SUBMITTED TO THE CITY FOR APPROVAL.

SUBGRADE

COMPACTED SUBGRADE (SEE SECTION 1.A.18)

APPLY TACK COAT PER NCDOT "STD. SPECS. FOR ROADS AND STRUCTURES," SECTION 605

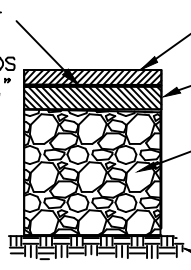

TYPICAL PAVEMENT SECTION

NOTES:

1. 2' BUFFER CAN BE ADDITIONAL R/W OR SIDEWALK UTILITY EASEMENT.
2. PLANTING STRIP ADJACENT TO SIDEWALK SHALL BE GRADED TO 1/4" PER FOOT (MIN.) UP TO 1 1/4" PER FOOT (MAX.), EXCEPT WHERE EXCESSIVE NATURAL GRADES MAKE THIS REQUIREMENT IMPRACTICAL. IN SUCH CASES, CDOT MAY AUTHORIZE A SUITABLE GRADE.
3. IF AMENITY ZONE IS AUTHORIZED IN PLACE OF PLANTING STRIP, CONCRETE SHALL BE 4" THICK AND CROSS SLOPE SHALL BE 1.5% (2% MAX).

KEY

- (R) 2'-6" STANDARD CURB AND GUTTER OR 2'-0" VALLEY GUTTER
- (S) 4" CONCRETE SIDEWALK
- 4. MIN. 11' LANES REQUIRED IF USED IN ETJ

NOT TO SCALE



CITY OF CHARLOTTE
LAND DEVELOPMENT STANDARDS
 INCLUDES CHARLOTTE ETJ

LOCAL RESIDENTIAL MEDIUM STREET
 TYPICAL SECTION (6' SIDEWALK)

STD. NO.	REV.
U-02A	23

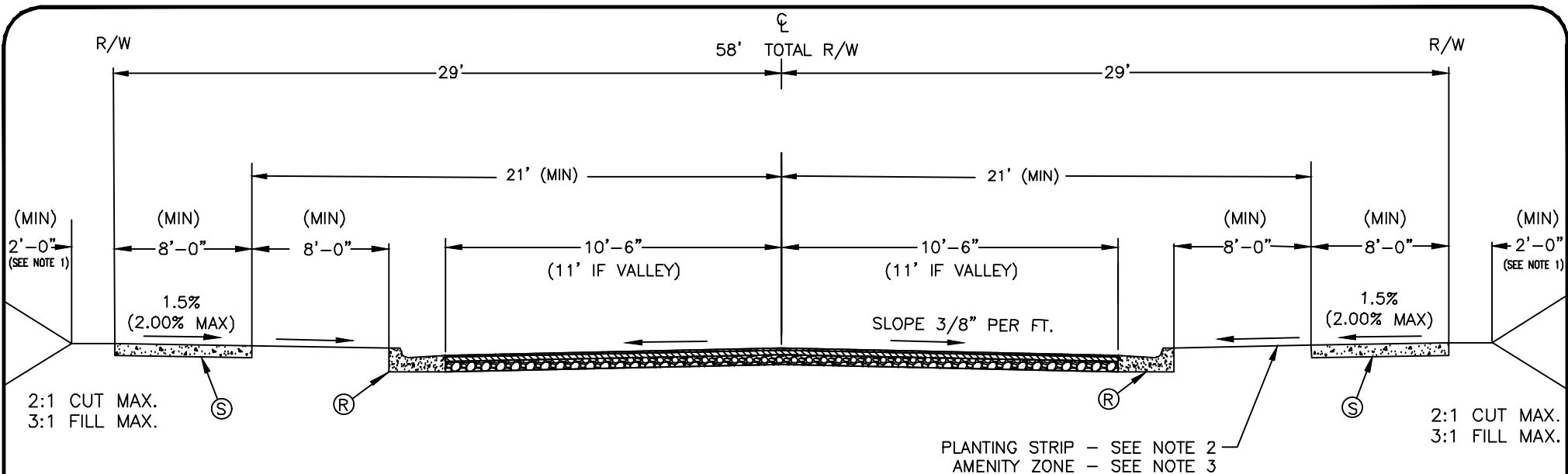

PLANTING STRIP - SEE NOTE 2
 AMENITY ZONE - SEE NOTE 3

SURFACE COURSE

1" S9.5B

FINAL LIFT TO BE APPLIED UPON MEETING ONE OF THE FOLLOWING CONDITIONS:

- 1) 75% DEVELOPMENT OCCUPANCY,
- 2) 1 YEAR FROM INTERMEDIATE COURSE PLACEMENT,
- 3) FOR ETJ STREETS, FINAL 1" MAY BE PLACED WHEN APPROVED BY NCDOT.

INTERMEDIATE COURSE

1 1/2" S9.5C OR S9.5B

BASE COURSE

8" COMPACTED AGGREGATE BASE COURSE, OR 4" BCBC TYPE B25.0C. SHOULD ENTIRE DEVELOPMENT HAVE A CBR OF 6 OR GREATER, THEN AN ALTERNATIVE BASE COURSE PAVEMENT DESIGN MAY BE SUBMITTED TO THE CITY FOR APPROVAL.

SUBGRADE

COMPACTED SUBGRADE (SEE SECTION 1.A.18)

APPLY TACK COAT PER NCDOT "STD. SPECS. FOR ROADS AND STRUCTURES," SECTION 605

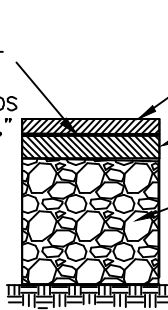

NOTES:

1. 2' BUFFER CAN BE ADDITIONAL R/W OR SIDEWALK UTILITY EASEMENT.
2. PLANTING STRIP ADJACENT TO SIDEWALK SHALL BE GRADED TO 1/4" PER FOOT (MIN.) UP TO 1 1/4" PER FOOT (MAX.), EXCEPT WHERE EXCESSIVE NATURAL GRADES MAKE THIS REQUIREMENT IMPRACTICAL. IN SUCH CASES, CDOT MAY AUTHORIZE A SUITABLE GRADE.
3. IF AMENITY ZONE IS AUTHORIZED IN PLACE OF PLANTING STRIP, CONCRETE SHALL BE 4" THICK AND CROSS SLOPE SHALL BE 1.5% (2% MAX).

TYPICAL PAVEMENT SECTION

KEY

- (R) 2'-6" STANDARD CURB AND GUTTER OR 2'-0" VALLEY GUTTER 4. MIN. 11' LANES REQUIRED IF USED IN ETJ
 (S) 4" CONCRETE SIDEWALK

NOT TO SCALE



CITY OF CHARLOTTE
 LAND DEVELOPMENT STANDARDS
 INCLUDES CHARLOTTE ETJ

LOCAL RESIDENTIAL MEDIUM STREET
 TYPICAL SECTION (8' SIDEWALK)

STD. NO.	REV.
U-02B	23

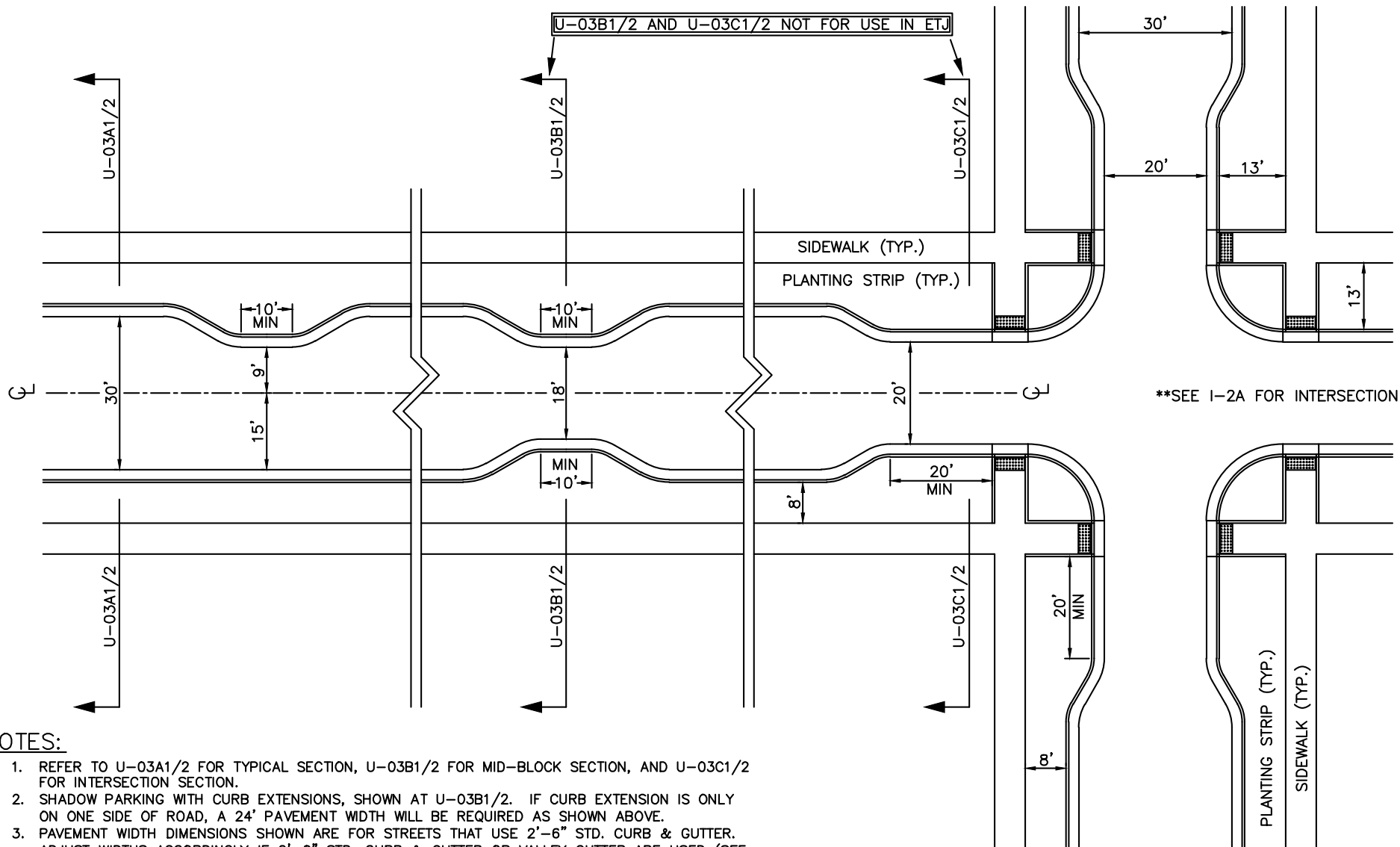

NOTES:

1. REFER TO U-03A1/2 FOR TYPICAL SECTION, U-03B1/2 FOR MID-BLOCK SECTION, AND U-03C1/2 FOR INTERSECTION SECTION.
2. SHADOW PARKING WITH CURB EXTENSIONS, SHOWN AT U-03B1/2. IF CURB EXTENSION IS ONLY ON ONE SIDE OF ROAD, A 24' PAVEMENT WIDTH WILL BE REQUIRED AS SHOWN ABOVE.
3. PAVEMENT WIDTH DIMENSIONS SHOWN ARE FOR STREETS THAT USE 2'-6" STD. CURB & GUTTER. ADJUST WIDTHS ACCORDINGLY IF 2'-0" STD. CURB & GUTTER OR VALLEY GUTTER ARE USED (SEE DETAILS U-03 A1, A2, B1, B2, C1, AND C2 FOR MORE INFO.)

NOT TO SCALE



**CITY OF CHARLOTTE
LAND DEVELOPMENT STANDARDS**

**LOCAL RESIDENTIAL WIDE STREET
PLAN VIEW**

STD. NO.	REV.
U-03	23

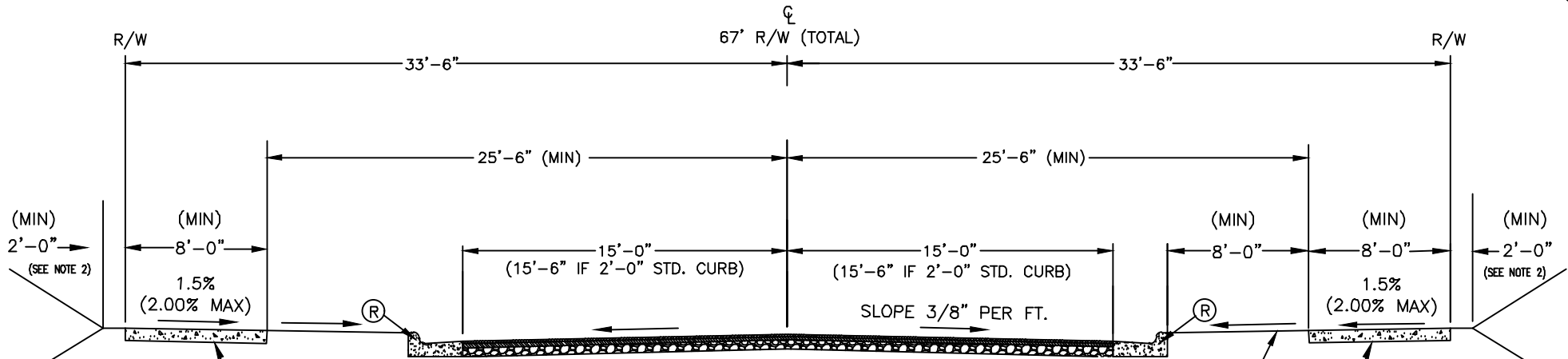

2:1 CUT MAX.
3:1 FILL MAX.

APPLY TACK COAT
PER NCDOT "STD.
SPECS. FOR
ROADS AND
STRUCTURES," 605

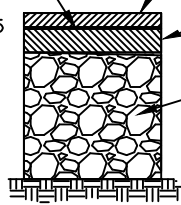

SURFACE COURSE

1" S9.5B

FINAL LIFT TO BE APPLIED UPON MEETING ONE OF THE FOLLOWING CONDITIONS:

- 1) 75% DEVELOPMENT OCCUPANCY,
- 2) 1 YEAR FROM INTERMEDIATE COURSE PLACEMENT,
- 3) FOR ETJ STREETS, FINAL 1" MAY BE PLACED WHEN APPROVED BY NCDOT.

INTERMEDIATE COURSE

1 1/2" S9.5C OR S9.5B

BASE COURSE

8" COMPACTED AGGREGATE BASE COURSE, OR 4" BCBC TYPE B25.0C. SHOULD ENTIRE DEVELOPMENT HAVE A CBR OF 6 OR GREATER, THEN AN ALTERNATIVE BASE COURSE PAVEMENT DESIGN MAY BE SUBMITTED TO THE CITY.

SUBGRADE

COMPACTED SUBGRADE (SEE SECTION I.A.18)

PLANTING STRIP - SEE NOTE 7
AMENITY ZONE - SEE NOTE 4

2:1 CUT MAX.
3:1 FILL MAX.

NOTES:

1. VALLEY GUTTER IS ALLOWED ONLY WITH PRIOR APPROVAL FROM CITY.
2. 2' BUFFER CAN BE SUE OR ADDITIONAL R/W.
3. AN ALTERNATIVE PAVEMENT DESIGN MAY BE REQUIRED BY CDOT/NCDOT BASED ON SPECIFIC TRAFFIC PARAMETERS.
4. IF AMENITY ZONE IS AUTHORIZED IN PLACE OF PLANTING STRIP, CONCRETE SHALL BE 4" THICK AND CROSS SLOPE SHALL BE 1.5% (2% MAX).
5. SEE PARKING STANDARD DETAILS #50.09A, B, & C FOR INFORMATION REGARDING ON-STREET "HEAD-IN" PARKING.
6. ON STREETS WITH FREQUENT DRIVEWAYS THAT PRECLUDE ON-STREET PARKING, USE DETAIL #U-03C1.
7. PLANTING STRIP ADJACENT TO SIDEWALK SHALL BE GRADED TO 1/4" PER FOOT (MIN.) UP TO 1 1/4" PER FOOT (MAX.), EXCEPT WHERE EXCESSIVE NATURAL GRADES MAKE THIS REQUIREMENT IMPRACTICAL. IN SUCH CASES, CDOT MAY AUTHORIZE A SUITABLE GRADE.

TYPICAL PAVEMENT SECTION

KEY

- (R) 2'-6" STANDARD CURB AND GUTTER,
2'-0" STANDARD CURB AND GUTTER, OR
2'-0" VALLEY GUTTER (SEE NOTE 1)
- (S) 4" CONCRETE SIDEWALK

NOT TO SCALE



CITY OF CHARLOTTE
LAND DEVELOPMENT STANDARDS
INCLUDES CHARLOTTE ETJ

LOCAL RESIDENTIAL WIDE STREET
TYPICAL SECTION (8' SIDEWALK)

STD. NO.	REV.
U-03A1	23

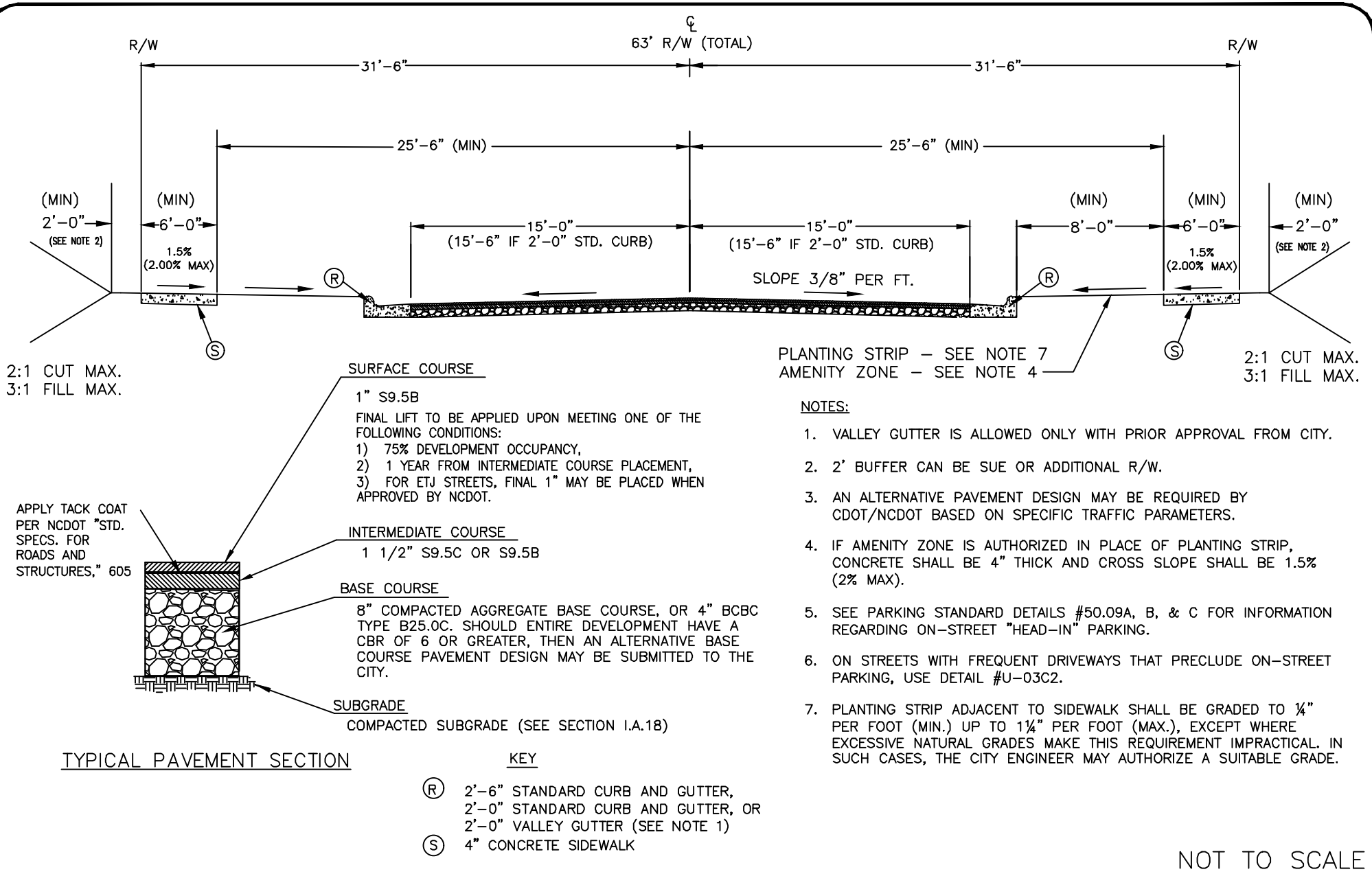

CITY OF CHARLOTTE
LAND DEVELOPMENT STANDARDS
INCLUDES CHARLOTTE ETJ

LOCAL RESIDENTIAL WIDE STREET
TYPICAL SECTION (6' SIDEWALK)

STD. NO.	REV.
U-03A2	23

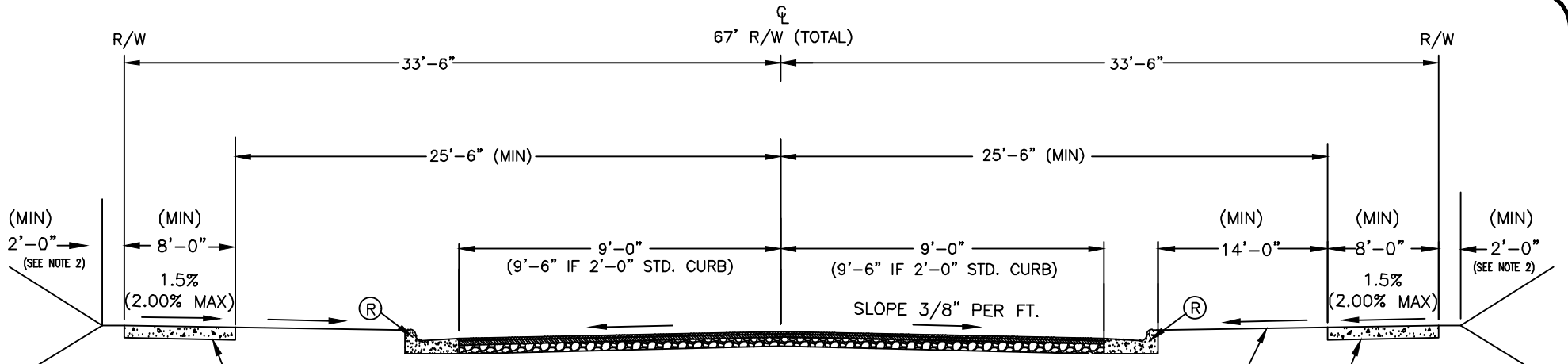

2:1 CUT MAX.
3:1 FILL MAX.

APPLY TACK COAT
PER NCDOT "STD.
SPECS. FOR
ROADS AND
STRUCTURES," 605

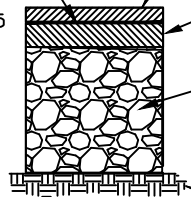

SURFACE COURSE

1" S9.5B
FINAL LIFT TO BE APPLIED UPON MEETING ONE OF THE FOLLOWING CONDITIONS:
1) 75% DEVELOPMENT OCCUPANCY,
2) 1 YEAR FROM INTERMEDIATE COURSE PLACEMENT,
3) FOR ETJ STREETS, FINAL 1" MAY BE PLACED WHEN APPROVED BY NCDOT.

INTERMEDIATE COURSE

1 1/2" S9.5C OR S9.5B

BASE COURSE

8" COMPACTED AGGREGATE BASE COURSE, OR 4" BCBC TYPE B25.0C. SHOULD ENTIRE DEVELOPMENT HAVE A CBR OF 6 OR GREATER, THEN AN ALTERNATIVE BASE COURSE PAVEMENT DESIGN MAY BE SUBMITTED TO THE CITY.

SUBGRADE

COMPACTED SUBGRADE (SEE SECTION I.A.18)

PLANTING STRIP - SEE NOTE 7
AMENITY ZONE - SEE NOTE 4

2:1 CUT MAX.
3:1 FILL MAX.

NOTES:

1. VALLEY GUTTER IS ALLOWED ONLY WITH PRIOR APPROVAL FROM CITY.
2. 2' BUFFER CAN BE SUE OR ADDITIONAL R/W.
3. AN ALTERNATIVE PAVEMENT DESIGN MAY BE REQUIRED BY CDOT/NCDOT BASED ON SPECIFIC TRAFFIC PARAMETERS.
4. IF AMENITY ZONE IS AUTHORIZED IN PLACE OF PLANTING STRIP, CONCRETE SHALL BE 4" THICK AND CROSS SLOPE SHALL BE 1.5% (2% MAX).
5. SEE PARKING STANDARD DETAILS #50.09A, B, & C FOR INFORMATION REGARDING ON-STREET "HEAD-IN" PARKING.
6. ON STREETS WITH FREQUENT DRIVEWAYS THAT PRECLUDE ON-STREET PARKING, USE DETAIL #U-03C1.
7. PLANTING STRIP ADJACENT TO SIDEWALK SHALL BE GRADED TO 1/4" PER FOOT (MIN.) UP TO 1 1/4" PER FOOT (MAX.), EXCEPT WHERE EXCESSIVE NATURAL GRADES MAKE THIS REQUIREMENT IMPRACTICAL. IN SUCH CASES, CDOT MAY AUTHORIZE A SUITABLE GRADE.

TYPICAL PAVEMENT SECTION

KEY

- (R) 2'-6" STANDARD CURB AND GUTTER,
2'-0" STANDARD CURB AND GUTTER, OR
2'-0" VALLEY GUTTER (SEE NOTE 1)
- (S) 4" CONCRETE SIDEWALK

NOT FOR USE IN ETJ

NOT TO SCALE



**CITY OF CHARLOTTE
LAND DEVELOPMENT STANDARDS**

LOCAL RESIDENTIAL WIDE STREET AT MIDBLOCK
WITH CURB EXTENSION TYPICAL SECTION (8' SIDEWALK)

STD. NO.	REV.
U-03B1	23

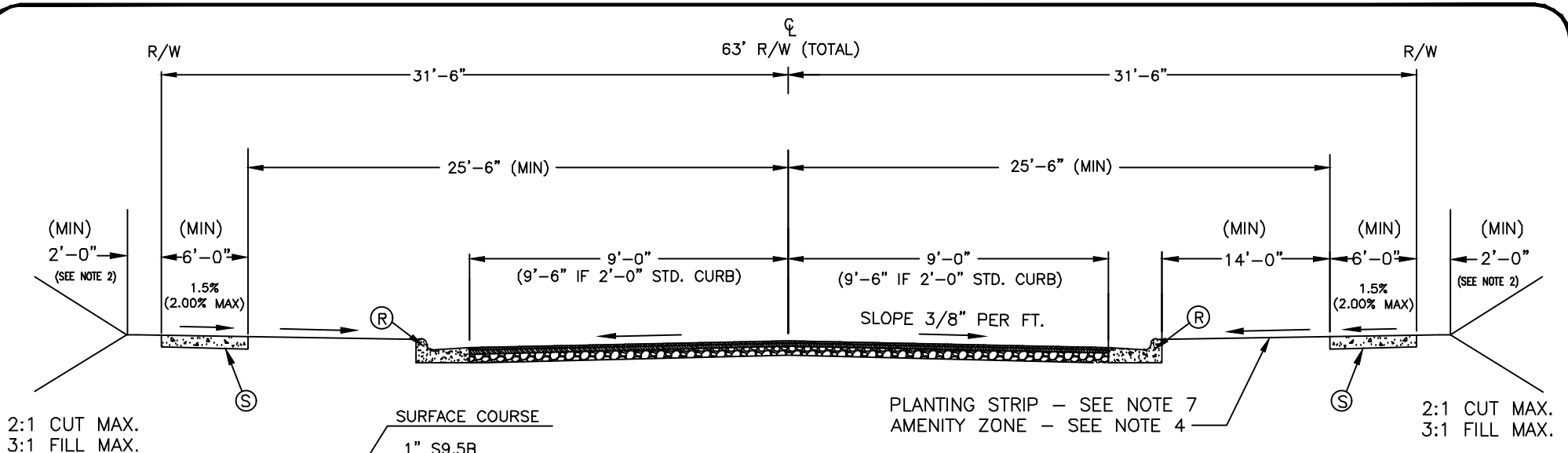

2:1 CUT MAX.
3:1 FILL MAX.

APPLY TACK COAT PER NCDOT "STD. SPECS. FOR ROADS AND STRUCTURES," 605

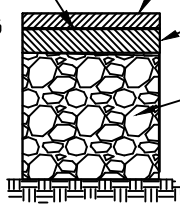

- SURFACE COURSE**
1" S9.5B
FINAL LIFT TO BE APPLIED UPON MEETING ONE OF THE FOLLOWING CONDITIONS:
1) 75% DEVELOPMENT OCCUPANCY,
2) 1 YEAR FROM INTERMEDIATE COURSE PLACEMENT,
3) FOR ETJ STREETS, FINAL 1" MAY BE PLACED WHEN APPROVED BY NCDOT.
- INTERMEDIATE COURSE**
1 1/2" S9.5C OR S9.5B
- BASE COURSE**
8" COMPACTED AGGREGATE BASE COURSE, OR 4" BCBC TYPE B25.0C. SHOULD ENTIRE DEVELOPMENT HAVE A CBR OF 6 OR GREATER, THEN AN ALTERNATIVE BASE COURSE PAVEMENT DESIGN MAY BE SUBMITTED TO THE CITY.
- SUBGRADE**
COMPACTED SUBGRADE (SEE SECTION I.A.18)

PLANTING STRIP - SEE NOTE 7
AMENITY ZONE - SEE NOTE 4

2:1 CUT MAX.
3:1 FILL MAX.

- NOTES:**
1. VALLEY GUTTER IS ALLOWED ONLY WITH PRIOR APPROVAL FROM CITY.
 2. 2' BUFFER CAN BE SUE OR ADDITIONAL R/W.
 3. AN ALTERNATIVE PAVEMENT DESIGN MAY BE REQUIRED BY CDOT/NCDOT BASED ON SPECIFIC TRAFFIC PARAMETERS.
 4. IF AMENITY ZONE IS AUTHORIZED IN PLACE OF PLANTING STRIP, CONCRETE SHALL BE 4" THICK AND CROSS SLOPE SHALL BE 1.5% (2% MAX).
 5. SEE PARKING STANDARD DETAILS #50.09A, B, & C FOR INFORMATION REGARDING ON-STREET "HEAD-IN" PARKING.
 6. ON STREETS WITH FREQUENT DRIVEWAYS THAT PRECLUDE ON-STREET PARKING, USE DETAIL #U-03C2.
 7. PLANTING STRIP ADJACENT TO SIDEWALK SHALL BE GRADED TO 1/4" PER FOOT (MIN.) UP TO 1 1/4" PER FOOT (MAX.), EXCEPT WHERE EXCESSIVE NATURAL GRADES MAKE THIS REQUIREMENT IMPRACTICAL. IN SUCH CASES, CDOT MAY AUTHORIZE A SUITABLE GRADE.

TYPICAL PAVEMENT SECTION

KEY

- (R) 2'-6" STANDARD CURB AND GUTTER,
2'-0" STANDARD CURB AND GUTTER, OR
2'-0" VALLEY GUTTER (SEE NOTE 1)
- (S) 4" CONCRETE SIDEWALK

NOT FOR USE IN ETJ

NOT TO SCALE



CITY OF CHARLOTTE
LAND DEVELOPMENT STANDARDS

LOCAL RESIDENTIAL WIDE STREET AT MIDBLOCK
WITH CURB EXTENSION TYPICAL SECTION (6' SIDEWALK)

STD. NO.	REV.
U-03B2	23

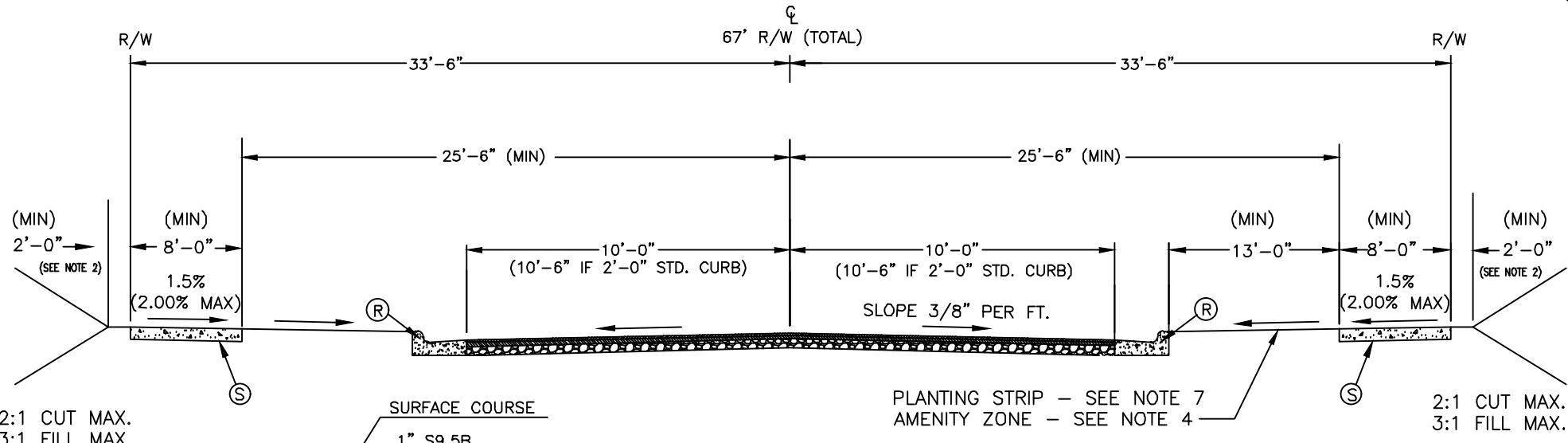

2:1 CUT MAX.
3:1 FILL MAX.

2:1 CUT MAX.
3:1 FILL MAX.

APPLY TACK COAT
PER NCDOT "STD.
SPECS. FOR
ROADS AND
STRUCTURES," 605

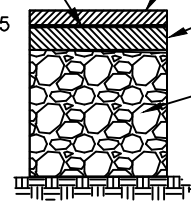

- SURFACE COURSE**
1" S9.5B
FINAL LIFT TO BE APPLIED UPON MEETING ONE OF THE FOLLOWING CONDITIONS:
1) 75% DEVELOPMENT OCCUPANCY,
2) 1 YEAR FROM INTERMEDIATE COURSE PLACEMENT,
3) FOR ETJ STREETS, FINAL 1" MAY BE PLACED WHEN APPROVED BY NCDOT.
- INTERMEDIATE COURSE**
1 1/2" S9.5C OR S9.5B
- BASE COURSE**
8" COMPACTED AGGREGATE BASE COURSE, OR 4" BCBC TYPE B25.0C. SHOULD ENTIRE DEVELOPMENT HAVE A CBR OF 6 OR GREATER, THEN AN ALTERNATIVE BASE COURSE PAVEMENT DESIGN MAY BE SUBMITTED TO THE CITY.
- SUBGRADE**
COMPACTED SUBGRADE (SEE SECTION I.A.18)

PLANTING STRIP - SEE NOTE 7
AMENITY ZONE - SEE NOTE 4

NOTES:

1. VALLEY GUTTER IS ALLOWED ONLY WITH PRIOR APPROVAL FROM CITY.
2. 2' BUFFER CAN BE SUE OR ADDITIONAL R/W.
3. AN ALTERNATIVE PAVEMENT DESIGN MAY BE REQUIRED BY CDOT/NCDOT BASED ON SPECIFIC TRAFFIC PARAMETERS.
4. IF AMENITY ZONE IS AUTHORIZED IN PLACE OF PLANTING STRIP, CONCRETE SHALL BE 4" THICK AND CROSS SLOPE SHALL BE 1.5% (2% MAX).
5. SEE PARKING STANDARD DETAILS #50.09A, B, & C FOR INFORMATION REGARDING ON-STREET "HEAD-IN" PARKING.
6. THIS DETAIL IS FOR USE ON STREETS WITH FREQUENT DRIVEWAYS THAT PRECLUDE ON-STREET PARKING.
7. PLANTING STRIP ADJACENT TO SIDEWALK SHALL BE GRADED TO 1/4" PER FOOT (MIN.) UP TO 1 1/4" PER FOOT (MAX.), EXCEPT WHERE EXCESSIVE NATURAL GRADES MAKE THIS REQUIREMENT IMPRACTICAL. IN SUCH CASES, CDOT MAY AUTHORIZE A SUITABLE GRADE.

TYPICAL PAVEMENT SECTION

KEY

- (R) 2'-6" STANDARD CURB AND GUTTER,
2'-0" STANDARD CURB AND GUTTER, OR
2'-0" VALLEY GUTTER (SEE NOTE 1)
- (S) 4" CONCRETE SIDEWALK

NOT FOR USE IN ETJ

NOT TO SCALE



**CITY OF CHARLOTTE
LAND DEVELOPMENT STANDARDS**

LOCAL RESIDENTIAL WIDE STREET AT INTERSECTION
WITH CURB EXTENSION TYPICAL SECTION (8' SIDEWALK)

STD. NO.	REV.
U-03C1	23

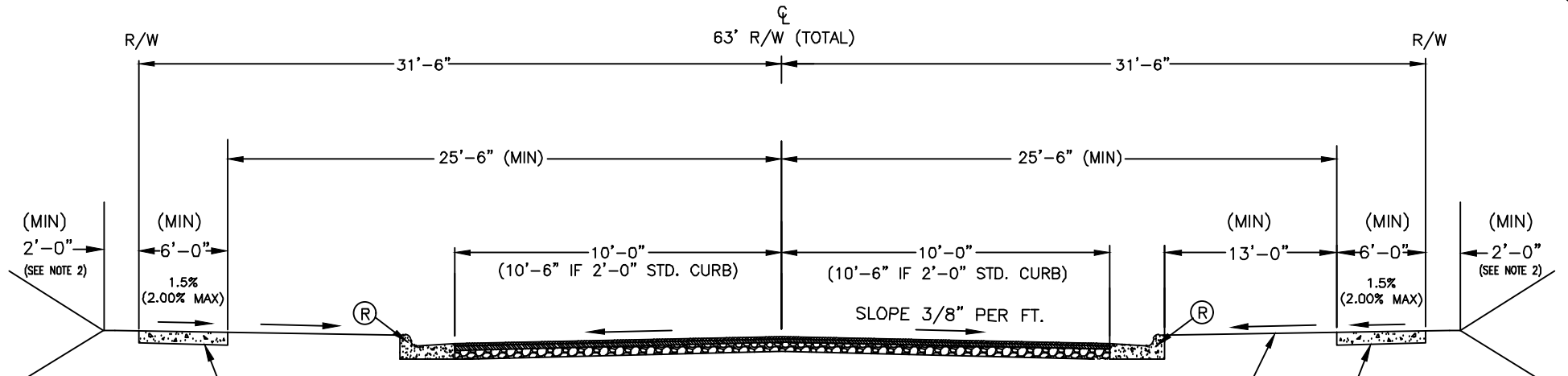

2:1 CUT MAX.
3:1 FILL MAX.

PLANTING STRIP - SEE NOTE 7
AMENITY ZONE - SEE NOTE 4

2:1 CUT MAX.
3:1 FILL MAX.

APPLY TACK COAT
PER NCDOT "STD.
SPECS. FOR
ROADS AND
STRUCTURES," 605

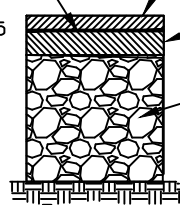

- SURFACE COURSE**
1" S9.5B
FINAL LIFT TO BE APPLIED UPON MEETING ONE OF THE FOLLOWING CONDITIONS:
1) 75% DEVELOPMENT OCCUPANCY,
2) 1 YEAR FROM INTERMEDIATE COURSE PLACEMENT,
3) FOR ETJ STREETS, FINAL 1" MAY BE PLACED WHEN APPROVED BY NCDOT.
- INTERMEDIATE COURSE**
1 1/2" S9.5C OR S9.5B
- BASE COURSE**
8" COMPACTED AGGREGATE BASE COURSE, OR 4" BCBC TYPE B25.0C. SHOULD ENTIRE DEVELOPMENT HAVE A CBR OF 6 OR GREATER, THEN AN ALTERNATIVE BASE COURSE PAVEMENT DESIGN MAY BE SUBMITTED TO THE CITY.
- SUBGRADE**
COMPACTED SUBGRADE (SEE SECTION I.A.18)

- NOTES:**
1. VALLEY GUTTER IS ALLOWED ONLY WITH PRIOR APPROVAL FROM CITY.
 2. 2' BUFFER CAN BE SUE OR ADDITIONAL R/W.
 3. AN ALTERNATIVE PAVEMENT DESIGN MAY BE REQUIRED BY CDOT/NCDOT BASED ON SPECIFIC TRAFFIC PARAMETERS.
 4. IF AMENITY ZONE IS AUTHORIZED IN PLACE OF PLANTING STRIP, CONCRETE SHALL BE 4" THICK AND CROSS SLOPE SHALL BE 1.5% (2% MAX).
 5. SEE PARKING STANDARD DETAILS #50.09A, B, & C FOR INFORMATION REGARDING ON-STREET "HEAD-IN" PARKING.
 6. THIS DETAIL IS FOR USE ON STREETS WITH FREQUENT DRIVEWAYS THAT PRECLUDE ON-STREET PARKING.
 7. PLANTING STRIP ADJACENT TO SIDEWALK SHALL BE GRADED TO 1/4" PER FOOT (MIN.) UP TO 1 1/4" PER FOOT (MAX.), EXCEPT WHERE EXCESSIVE NATURAL GRADES MAKE THIS REQUIREMENT IMPRACTICAL. IN SUCH CASES, CDOT MAY AUTHORIZE A SUITABLE GRADE.

TYPICAL PAVEMENT SECTION

KEY

- (R) 2'-6" STANDARD CURB AND GUTTER,
2'-0" STANDARD CURB AND GUTTER, OR
2'-0" VALLEY GUTTER (SEE NOTE 1)
- (S) 4" CONCRETE SIDEWALK

NOT FOR USE IN ETJ

NOT TO SCALE



**CITY OF CHARLOTTE
LAND DEVELOPMENT STANDARDS**

LOCAL RESIDENTIAL WIDE STREET AT INTERSECTION
WITH CURB EXTENSION TYPICAL SECTION (6' SIDEWALK)

STD. NO.	REV.
U-03C2	23

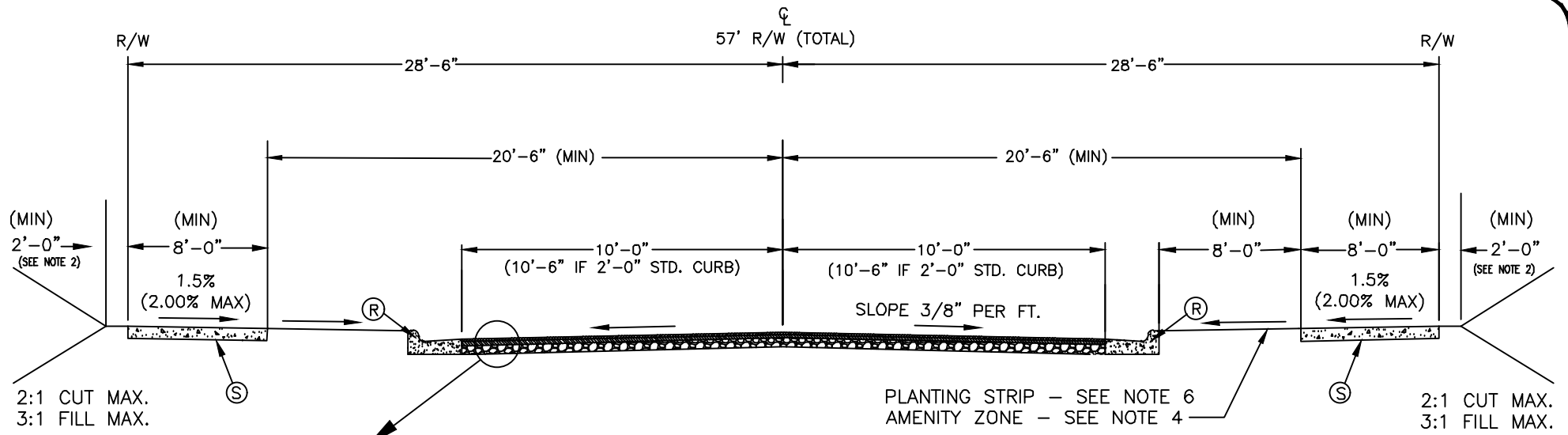

EITHER OF THESE PAVEMENT SECTIONS MAY BE USED:

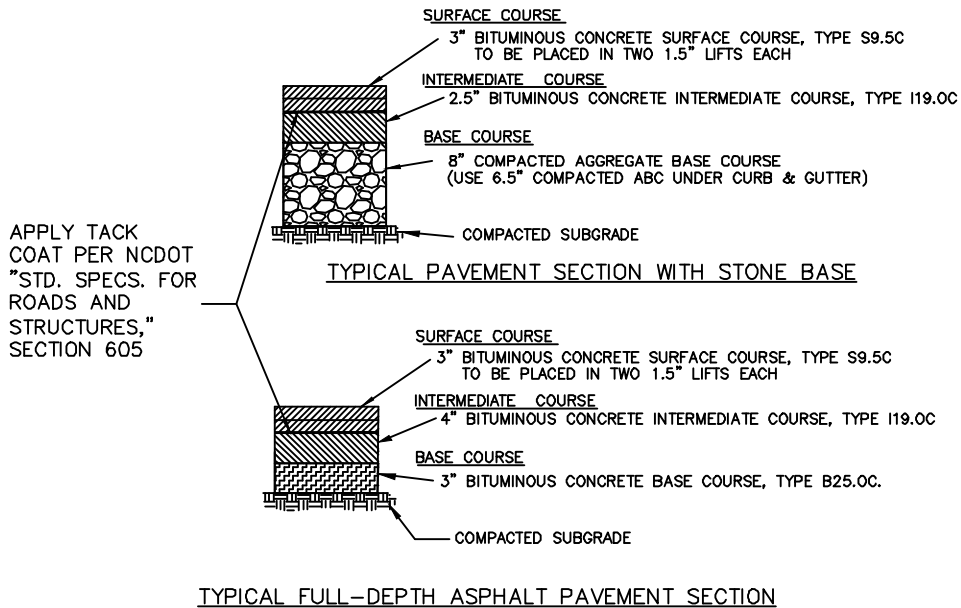

NOTES:

1. USE OF VALLEY GUTTER PROHIBITED.
2. 2' BUFFER CAN BE SUE OR ADDITIONAL R/W.
3. AN ALTERNATIVE PAVEMENT DESIGN MAY BE REQUIRED BY CDOT BASED ON SPECIFIC TRAFFIC PARAMETERS.
4. IF AMENITY ZONE IS AUTHORIZED IN PLACE OF PLANTING STRIP, CONCRETE SHALL BE 4" THICK AND CROSS SLOPE SHALL BE 1.5% (2% MAX).
5. DEVELOPER MAY SUBMIT AN ALTERNATIVE PAVEMENT SECTION DESIGN TO CITY.
6. PLANTING STRIP ADJACENT TO SIDEWALK SHALL BE GRADED TO 1/4" PER FOOT (MIN.) UP TO 1 1/4" PER FOOT (MAX.), EXCEPT WHERE EXCESSIVE NATURAL GRADES MAKE THIS REQUIREMENT IMPRACTICAL. IN SUCH CASES, CDOT MAY AUTHORIZE A SUITABLE GRADE.

KEY

- (R) 2'-6" STANDARD CURB AND GUTTER, 2'-0" STANDARD CURB AND GUTTER, OR 2'-0" VALLEY GUTTER (SEE NOTE 1)
- (S) 4" CONCRETE SIDEWALK

NOT FOR USE IN ETJ

NOT TO SCALE



**CITY OF CHARLOTTE
LAND DEVELOPMENT STANDARDS**

LOCAL OFFICE/COMMERCIAL NARROW STREET
TYPICAL SECTION (8' SIDEWALK)

STD. NO.	REV.
U-04A	23

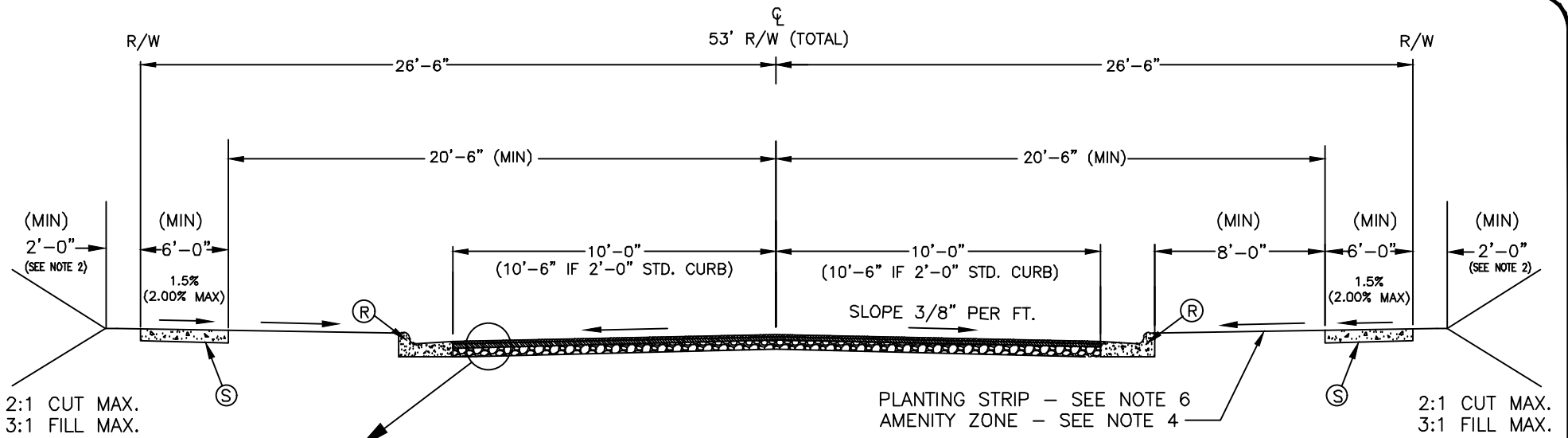

2:1 CUT MAX.
3:1 FILL MAX.

PLANTING STRIP - SEE NOTE 6
AMENITY ZONE - SEE NOTE 4

2:1 CUT MAX.
3:1 FILL MAX.

EITHER OF THESE PAVEMENT SECTIONS MAY BE USED:

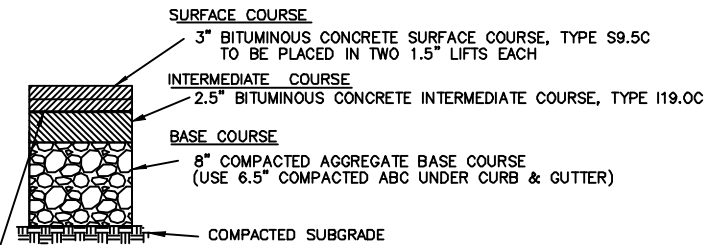

TYPICAL PAVEMENT SECTION WITH STONE BASE

APPLY TACK COAT PER NCDOT "STD. SPECS. FOR ROADS AND STRUCTURES," SECTION 605

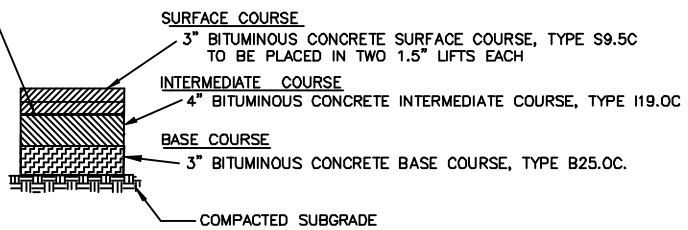

TYPICAL FULL-DEPTH ASPHALT PAVEMENT SECTION

NOTES:

1. USE OF VALLEY GUTTER PROHIBITED.
2. 2' BUFFER CAN BE SUE OR ADDITIONAL R/W.
3. AN ALTERNATIVE PAVEMENT DESIGN MAY BE REQUIRED BY CDOT BASED ON SPECIFIC TRAFFIC PARAMETERS.
4. IF AMENITY ZONE IS AUTHORIZED IN PLACE OF PLANTING STRIP, CONCRETE SHALL BE 4" THICK AND CROSS SLOPE SHALL BE 1.5% (2% MAX).
5. DEVELOPER MAY SUBMIT AN ALTERNATIVE PAVEMENT SECTION DESIGN TO CITY.
6. PLANTING STRIP ADJACENT TO SIDEWALK SHALL BE GRADED TO 1/4" PER FOOT (MIN.) UP TO 1 1/4" PER FOOT (MAX.), EXCEPT WHERE EXCESSIVE NATURAL GRADES MAKE THIS REQUIREMENT IMPRACTICAL. IN SUCH CASES, CDOT MAY AUTHORIZE A SUITABLE GRADE.

KEY

- (R) 2'-6" STANDARD CURB AND GUTTER,
2'-0" STANDARD CURB AND GUTTER, OR
2'-0" VALLEY GUTTER (SEE NOTE 1)
- (S) 4" CONCRETE SIDEWALK

NOT FOR USE IN ETJ

NOT TO SCALE



CITY OF CHARLOTTE
LAND DEVELOPMENT STANDARDS

LOCAL OFFICE/COMMERCIAL NARROW STREET
TYPICAL SECTION (6' SIDEWALK)

STD. NO.	REV.
U-04B	23

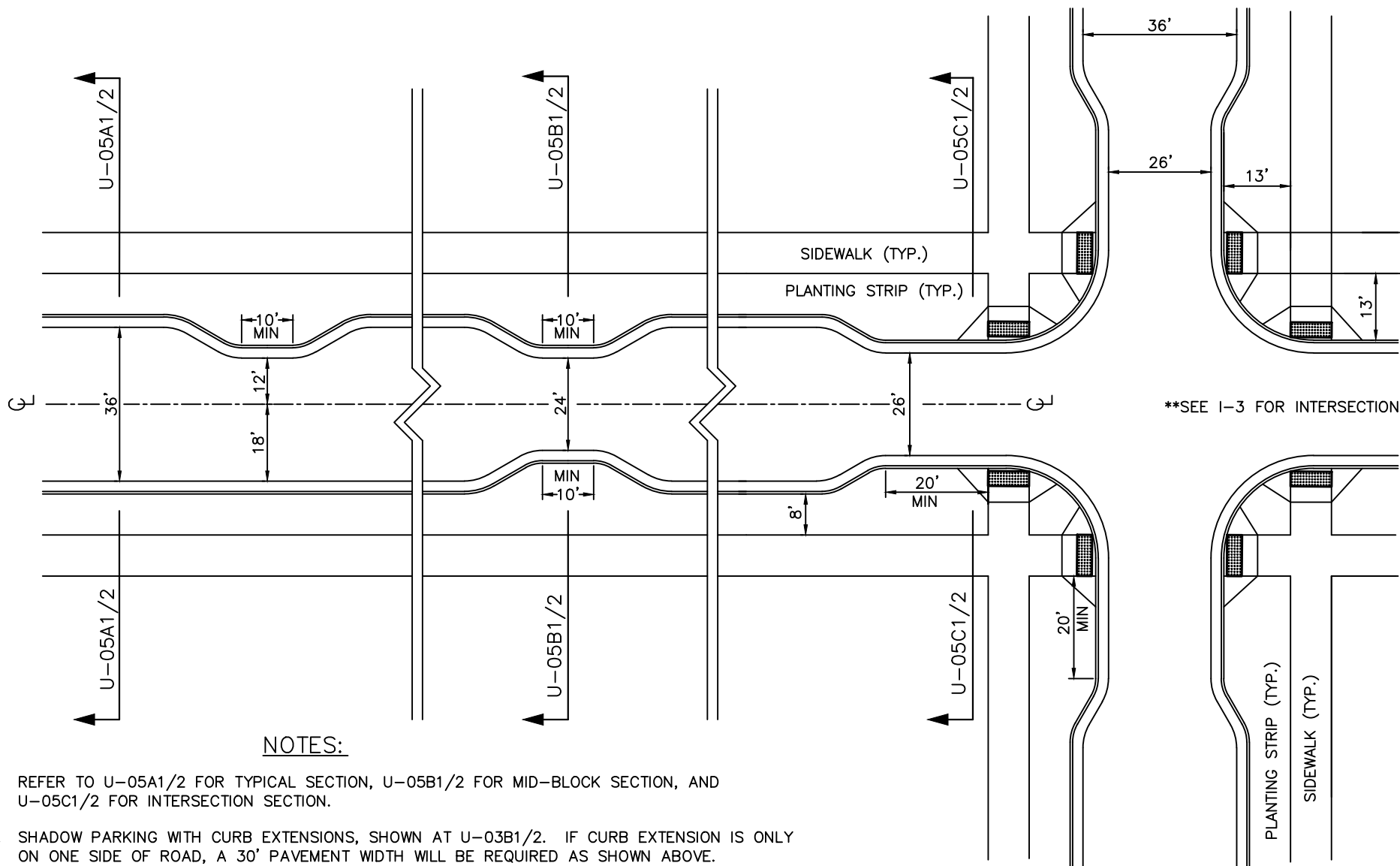

NOTES:

1. REFER TO U-05A1/2 FOR TYPICAL SECTION, U-05B1/2 FOR MID-BLOCK SECTION, AND U-05C1/2 FOR INTERSECTION SECTION.
2. SHADOW PARKING WITH CURB EXTENSIONS, SHOWN AT U-03B1/2. IF CURB EXTENSION IS ONLY ON ONE SIDE OF ROAD, A 30' PAVEMENT WIDTH WILL BE REQUIRED AS SHOWN ABOVE.

NOT FOR USE IN ETJ

NOT TO SCALE



**CITY OF CHARLOTTE
LAND DEVELOPMENT STANDARDS**

**LOCAL OFFICE/COMMERCIAL WIDE STREET
PLAN VIEW**

STD. NO.	REV.
U-05	23

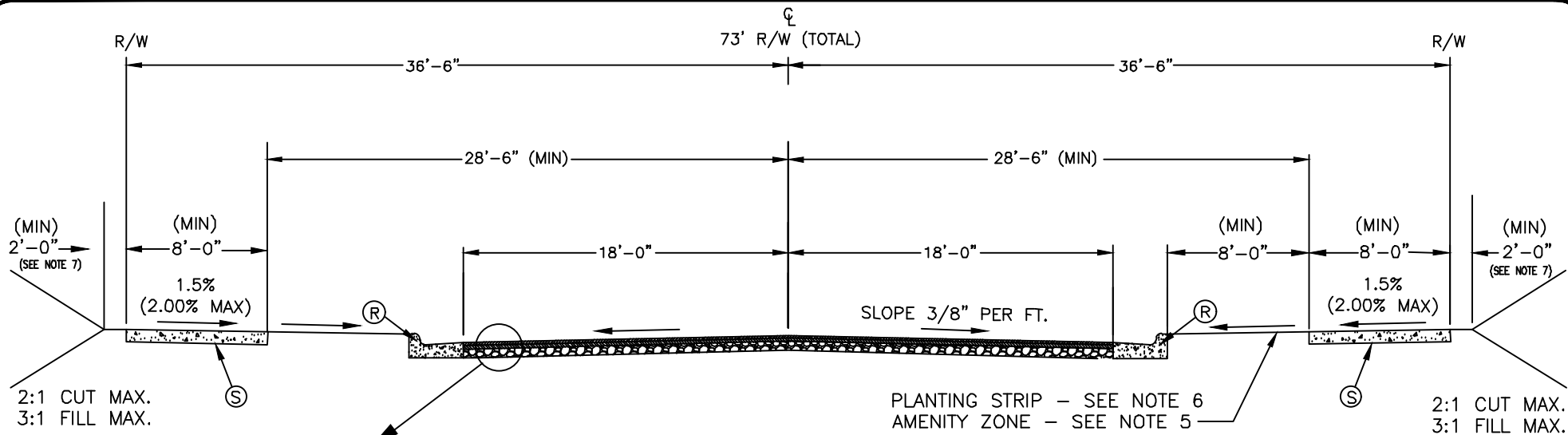

EITHER OF THESE PAVEMENT SECTIONS MAY BE USED:

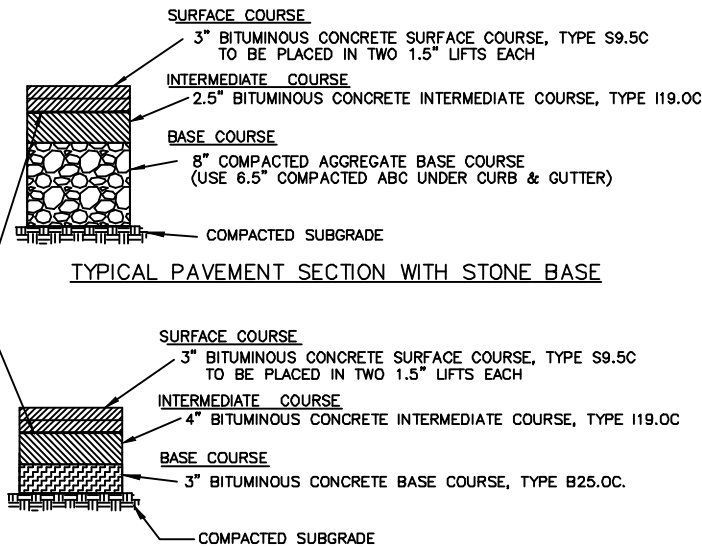

APPLY TACK COAT PER NCDOT "STD. SPECS. FOR ROADS AND STRUCTURES," SECTION 605

TYPICAL FULL-DEPTH ASPHALT PAVEMENT SECTION

NOTES:

1. USE OF VALLEY GUTTER IS PROHIBITED.
2. WIDER SIDEWALKS MAY BE REQUIRED UNDER CIRCUMSTANCES AS IDENTIFIED IN THE USDG.
3. DEVELOPER MAY SUBMIT AN ALTERNATIVE PAVEMENT DESIGN TO CITY.
4. AN ALTERNATIVE PAVEMENT DESIGN MAY BE REQUIRED BY CDOT/NCDOT BASED ON SPECIFIC TRAFFIC PARAMETERS.
5. IF AMENITY ZONE IS AUTHORIZED IN PLACE OF PLANTING STRIP, CONCRETE SHALL BE 4" THICK AND CROSS SLOPE SHALL BE 1.5% (2.0% MAX).
6. PLANTING STRIP ADJACENT TO SIDEWALK SHALL BE GRADED TO 1/4" PER FOOT (MIN.) UP TO 1 1/4" PER FOOT (MAX.), EXCEPT WHERE EXCESSIVE NATURAL GRADES MAKE THIS REQUIREMENT IMPRACTICAL. IN SUCH CASES, CDOT MAY AUTHORIZE A SUITABLE GRADE.
7. 2' BUFFER CAN BE SUE OR ADDITIONAL R/W

KEY

- (R) 2'-6" STANDARD CURB AND GUTTER ONLY
- (S) 4" CONCRETE SIDEWALK 3600 PSI AT 28 DAYS

NOT FOR USE IN ETJ

NOT TO SCALE



**CITY OF CHARLOTTE
LAND DEVELOPMENT STANDARDS**

LOCAL OFFICE/COMMERCIAL WIDE STREET
TYPICAL SECTION (8' SIDEWALK)

STD. NO.	REV.
U-05A1	23

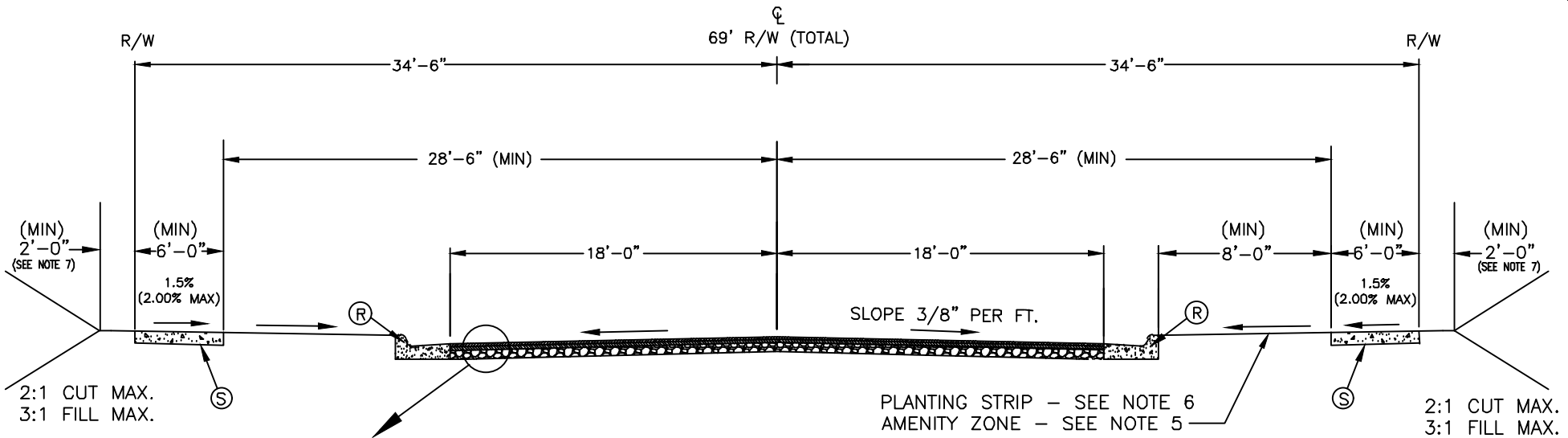

EITHER OF THESE PAVEMENT SECTIONS MAY BE USED:

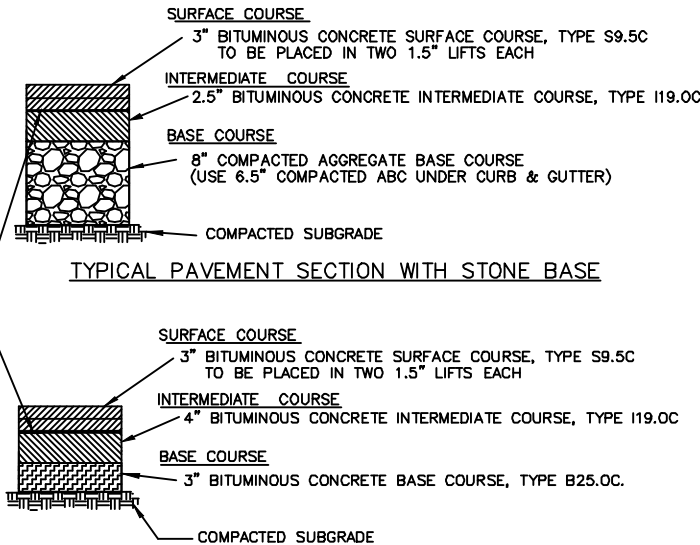

APPLY TACK COAT PER NCDOT "STD. SPECS. FOR ROADS AND STRUCTURES," SECTION 605

TYPICAL FULL-DEPTH ASPHALT PAVEMENT SECTION

NOTES:

1. USE OF VALLEY GUTTER IS PROHIBITED.
2. WIDER SIDEWALKS MAY BE REQUIRED UNDER CIRCUMSTANCES AS IDENTIFIED IN THE USDG.
3. DEVELOPER MAY SUBMIT AN ALTERNATIVE PAVEMENT DESIGN TO CITY.
4. AN ALTERNATIVE PAVEMENT DESIGN MAY BE REQUIRED BY CDOT/NCDOT BASED ON SPECIFIC TRAFFIC PARAMETERS.
5. IF AMENITY ZONE IS AUTHORIZED IN PLACE OF PLANTING STRIP, CONCRETE SHALL BE 4" THICK AND CROSS SLOPE SHALL BE 1.5% (2.0% MAX).
6. PLANTING STRIP ADJACENT TO SIDEWALK SHALL BE GRADED TO 1/4" PER FOOT (MIN.) UP TO 1 1/4" PER FOOT (MAX.), EXCEPT WHERE EXCESSIVE NATURAL GRADES MAKE THIS REQUIREMENT IMPRACTICAL. IN SUCH CASES, CDOT MAY AUTHORIZE A SUITABLE GRADE.
7. 2' BUFFER CAN BE SUB OR ADDITIONAL R/W

KEY

- (R) 2'-6" STANDARD CURB AND GUTTER ONLY
- (S) 4" CONCRETE SIDEWALK 3600 PSI AT 28 DAYS

NOT FOR USE IN ETJ

NOT TO SCALE



CITY OF CHARLOTTE
LAND DEVELOPMENT STANDARDS

LOCAL OFFICE/COMMERCIAL WIDE STREET
TYPICAL SECTION (6' SIDEWALK)

STD. NO.	REV.
U-05A2	23

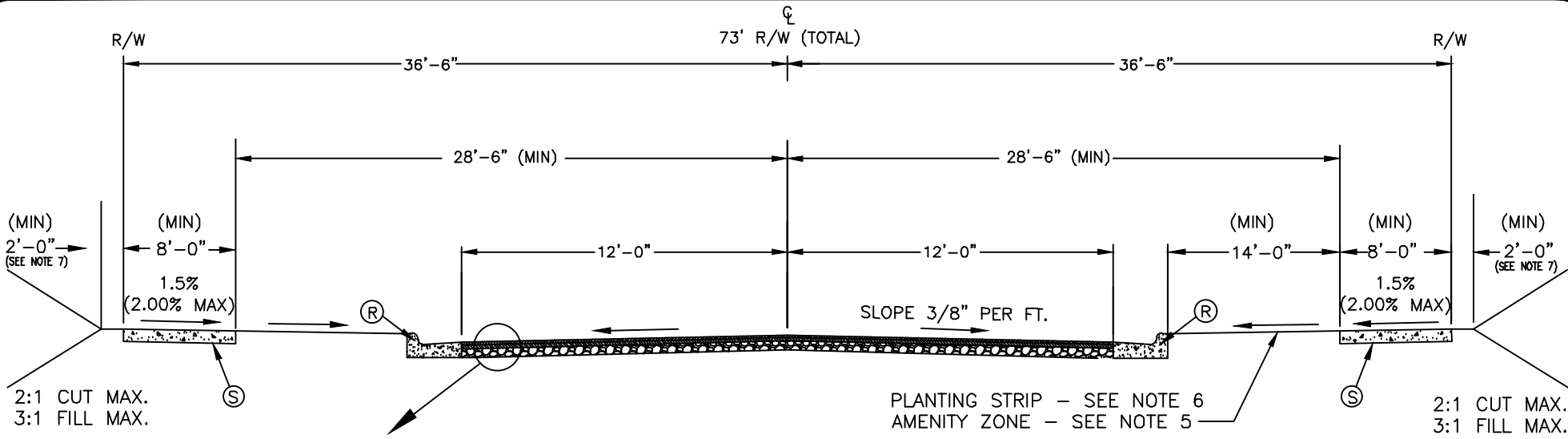

EITHER OF THESE PAVEMENT SECTIONS MAY BE USED:

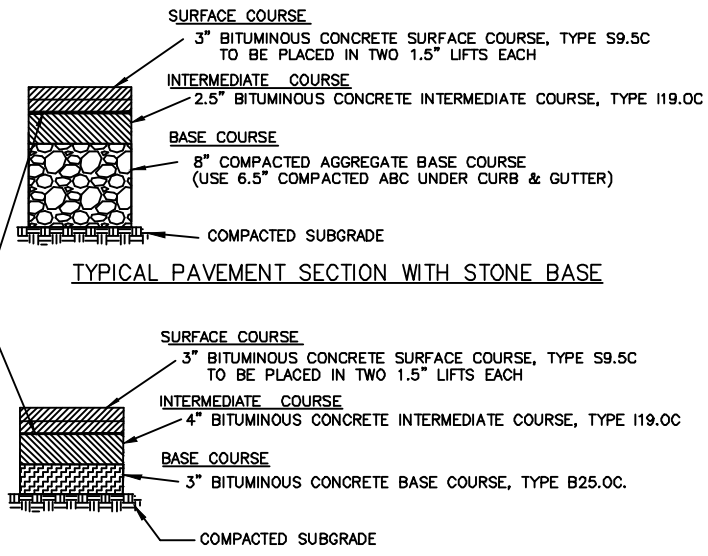

APPLY TACK COAT PER NCDOT "STD. SPECS. FOR ROADS AND STRUCTURES," SECTION 605

NOTES:

1. USE OF VALLEY GUTTER IS PROHIBITED.
2. WIDER SIDEWALKS MAY BE REQUIRED UNDER CIRCUMSTANCES AS IDENTIFIED IN THE USDG.
3. DEVELOPER MAY SUBMIT AN ALTERNATIVE PAVEMENT DESIGN TO CITY.
4. AN ALTERNATIVE PAVEMENT DESIGN MAY BE REQUIRED BY CDOT/NCDOT BASED ON SPECIFIC TRAFFIC PARAMETERS.
5. IF AMENITY ZONE IS AUTHORIZED IN PLACE OF PLANTING STRIP, CONCRETE SHALL BE 4" THICK AND CROSS SLOPE SHALL BE 1.5% (2.0% MAX).
6. PLANTING STRIP ADJACENT TO SIDEWALK SHALL BE GRADED TO 1/4" PER FOOT (MIN.) UP TO 1 1/4" PER FOOT (MAX.), EXCEPT WHERE EXCESSIVE NATURAL GRADES MAKE THIS REQUIREMENT IMPRACTICAL. IN SUCH CASES, CDOT MAY AUTHORIZE A SUITABLE GRADE.
7. 2' BUFFER CAN BE SUE OR ADDITIONAL R/W

KEY

- (R) 2'-6" STANDARD CURB AND GUTTER ONLY
- (S) 4" CONCRETE SIDEWALK

NOT FOR USE IN ETJ

NOT TO SCALE

STD. NO.	REV.
U-05B1	23

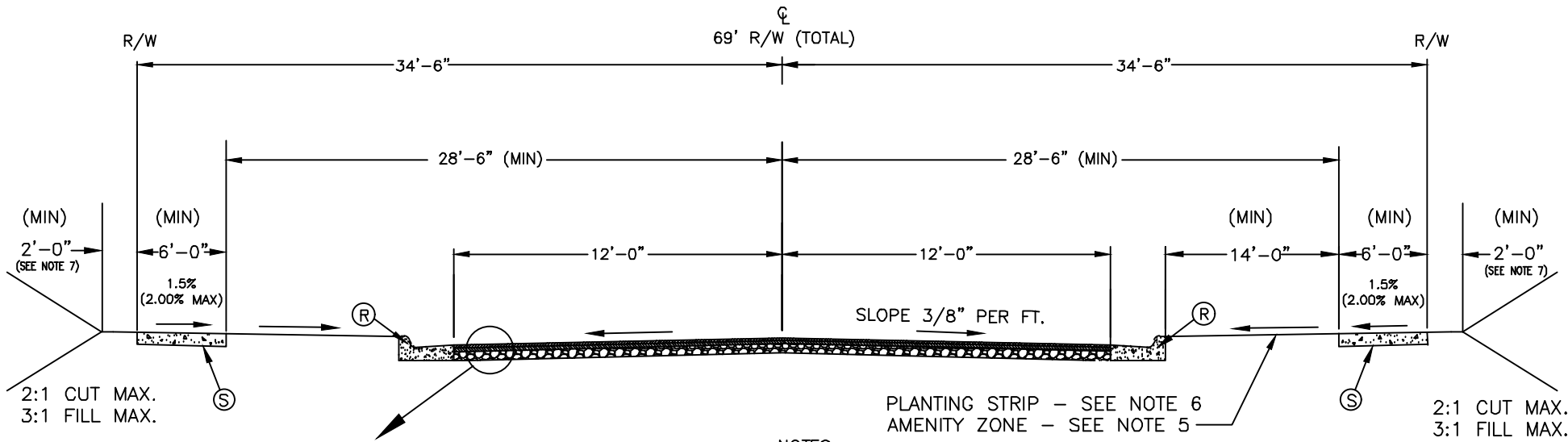

EITHER OF THESE PAVEMENT SECTIONS MAY BE USED:

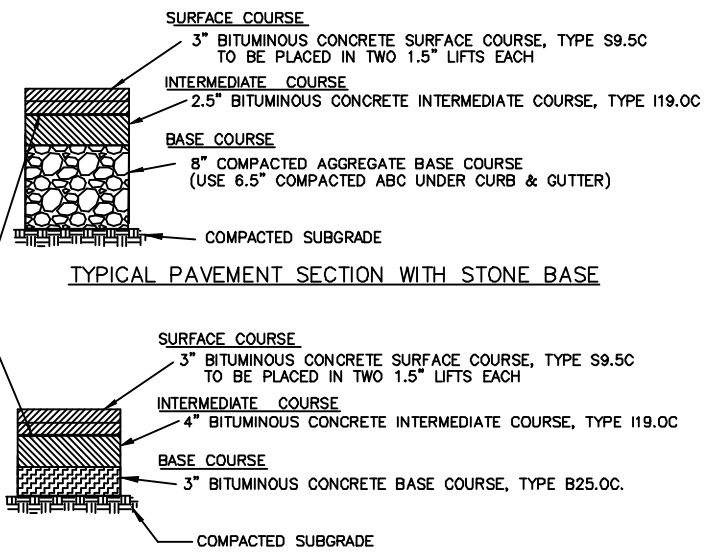

APPLY TACK COAT PER NCDOT "STD. SPECS. FOR ROADS AND STRUCTURES," SECTION 605

NOTES:

1. USE OF VALLEY GUTTER IS PROHIBITED.
2. WIDER SIDEWALKS MAY BE REQUIRED UNDER CIRCUMSTANCES AS IDENTIFIED IN THE USDG.
3. DEVELOPER MAY SUBMIT AN ALTERNATIVE PAVEMENT DESIGN TO CITY.
4. AN ALTERNATIVE PAVEMENT DESIGN MAY BE REQUIRED BY CDOT/NCDOT BASED ON SPECIFIC TRAFFIC PARAMETERS.
5. IF AMENITY ZONE IS AUTHORIZED IN PLACE OF PLANTING STRIP, CONCRETE SHALL BE 4" THICK AND CROSS SLOPE SHALL BE 1.5% (2% MAX).
6. PLANTING STRIP ADJACENT TO SIDEWALK SHALL BE GRADED TO 1/4" PER FOOT (MIN.) UP TO 1 1/4" PER FOOT (MAX.), EXCEPT WHERE EXCESSIVE NATURAL GRADES MAKE THIS REQUIREMENT IMPRACTICAL. IN SUCH CASES, CDOT MAY AUTHORIZE A SUITABLE GRADE.
7. 2' BUFFER CAN BE SUE OR ADDITIONAL R/W

KEY

- (R) 2'-6" STANDARD CURB AND GUTTER ONLY
- (S) 4" CONCRETE SIDEWALK

NOT FOR USE IN ETJ

NOT TO SCALE



**CITY OF CHARLOTTE
LAND DEVELOPMENT STANDARDS**

LOCAL OFFICE/COMMERCIAL WIDE STREET AT
MIDBLOCK WITH CURB EXTENSION TYPICAL SECTION
(6' SIDEWALK)

STD. NO.	REV.
U-05B2	23

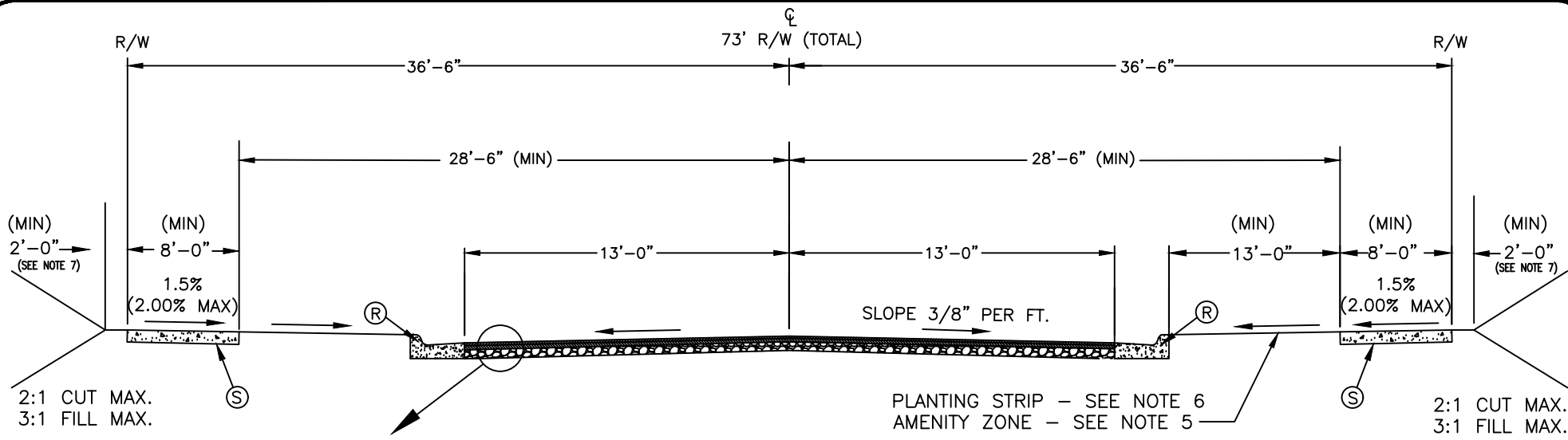

EITHER OF THESE PAVEMENT SECTIONS MAY BE USED:

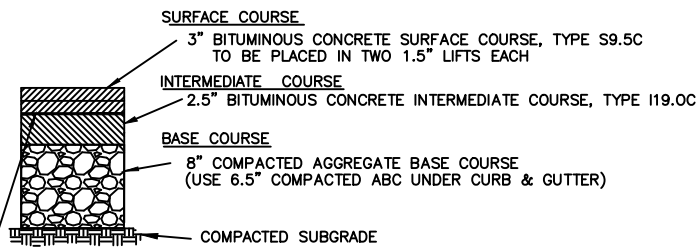

TYPICAL PAVEMENT SECTION WITH STONE BASE

APPLY TACK COAT PER NCDOT "STD. SPECS. FOR ROADS AND STRUCTURES," SECTION 605

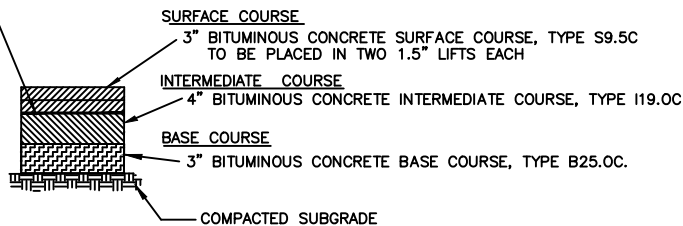

TYPICAL FULL-DEPTH ASPHALT PAVEMENT SECTION

NOTES:

1. USE OF VALLEY GUTTER IS PROHIBITED.
2. WIDER SIDEWALKS MAY BE REQUIRED UNDER CIRCUMSTANCES AS IDENTIFIED IN THE USDG.
3. DEVELOPER MAY SUBMIT AN ALTERNATIVE PAVEMENT DESIGN TO CITY.
4. AN ALTERNATIVE PAVEMENT DESIGN MAY BE REQUIRED BY CDOT/NCDOT BASED ON SPECIFIC TRAFFIC PARAMETERS.
5. IF AMENITY ZONE IS AUTHORIZED IN PLACE OF PLANTING STRIP, CONCRETE SHALL BE 4" THICK AND CROSS SLOPE SHALL BE 1.5% (2% MAX).
6. PLANTING STRIP ADJACENT TO SIDEWALK SHALL BE GRADED TO 1/4" PER FOOT (MIN.) UP TO 1 1/4" PER FOOT (MAX.), EXCEPT WHERE EXCESSIVE NATURAL GRADES MAKE THIS REQUIREMENT IMPRACTICAL. IN SUCH CASES, CDOT MAY AUTHORIZE A SUITABLE GRADE.
7. 2' BUFFER CAN BE SUE OR ADDITIONAL R/W

KEY

- (R) 2'-6" STANDARD CURB AND GUTTER ONLY
- (S) 4" CONCRETE SIDEWALK

NOT FOR USE IN ETJ

NOT TO SCALE



**CITY OF CHARLOTTE
LAND DEVELOPMENT STANDARDS**

LOCAL OFFICE/COMMERCIAL WIDE STREET AT
INTERSECTION WITH CURB EXTENSION TYPICAL SECTION
(8' SIDEWALK)

STD. NO.	REV.
U-05C1	23

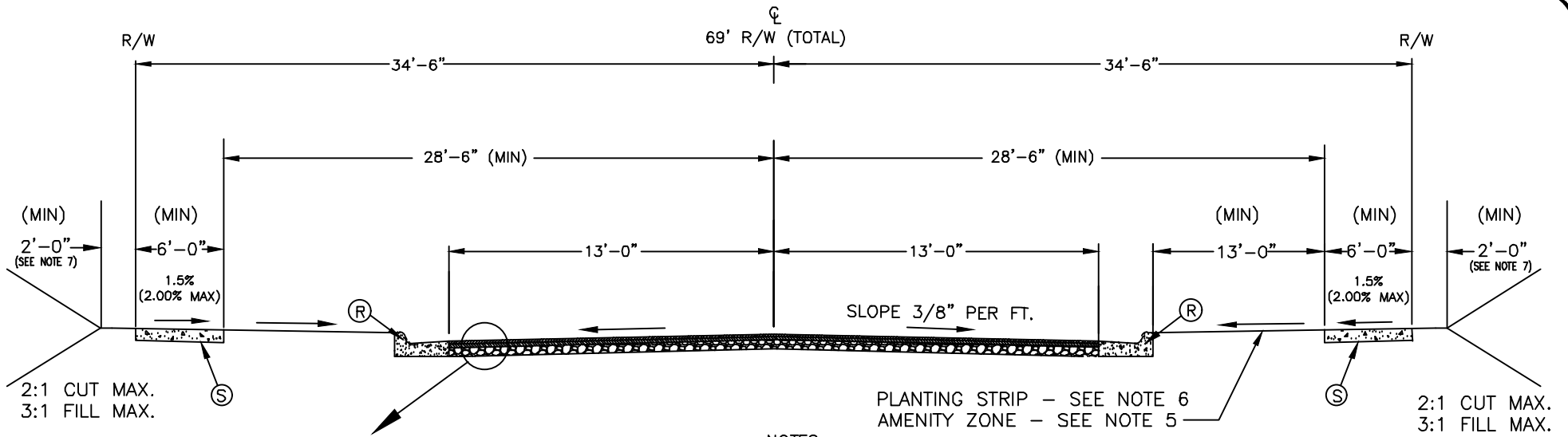

EITHER OF THESE PAVEMENT SECTIONS MAY BE USED:

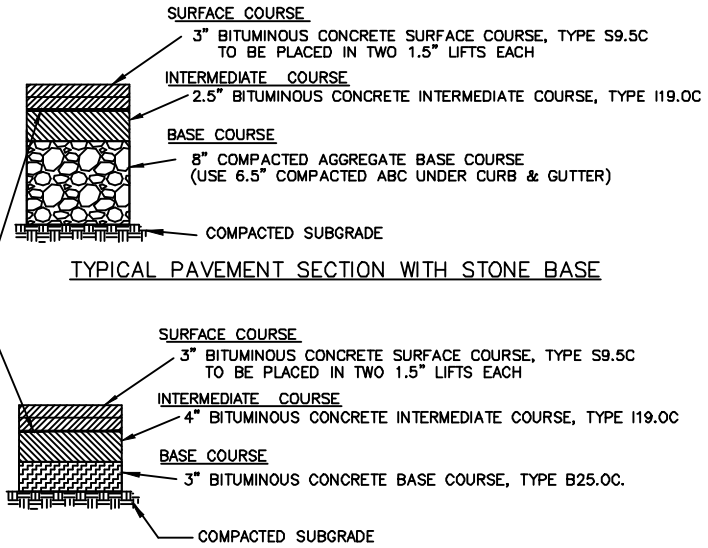

APPLY TACK COAT PER NCDOT "STD. SPECS. FOR ROADS AND STRUCTURES," SECTION 605

NOTES:

1. USE OF VALLEY GUTTER IS PROHIBITED.
2. WIDER SIDEWALKS MAY BE REQUIRED UNDER CIRCUMSTANCES AS IDENTIFIED IN THE USDG.
3. DEVELOPER MAY SUBMIT AN ALTERNATIVE PAVEMENT DESIGN TO CITY.
4. AN ALTERNATIVE PAVEMENT DESIGN MAY BE REQUIRED BY CDOT/NCDOT BASED ON SPECIFIC TRAFFIC PARAMETERS.
5. IF AMENITY ZONE IS AUTHORIZED IN PLACE OF PLANTING STRIP, CONCRETE SHALL BE 4" THICK AND CROSS SLOPE SHALL BE 1.5% (2.0% MAX).
6. PLANTING STRIP ADJACENT TO SIDEWALK SHALL BE GRADED TO 1/4" PER FOOT (MIN.) UP TO 1 1/4" PER FOOT (MAX.), EXCEPT WHERE EXCESSIVE NATURAL GRADES MAKE THIS REQUIREMENT IMPRACTICAL. IN SUCH CASES, CDOT MAY AUTHORIZE A SUITABLE GRADE.
7. 2' BUFFER CAN BE SUE OR ADDITIONAL R/W

KEY

- (R) 2'-6" STANDARD CURB AND GUTTER ONLY
- (S) 4" CONCRETE SIDEWALK

NOT FOR USE IN ETJ

NOT TO SCALE



**CITY OF CHARLOTTE
LAND DEVELOPMENT STANDARDS**

LOCAL OFFICE/COMMERCIAL WIDE STREET AT
MIDBLOCK WITH CURB EXTENSION TYPICAL SECTION
(6' SIDEWALK)

STD. NO.	REV.
U-05C2	23

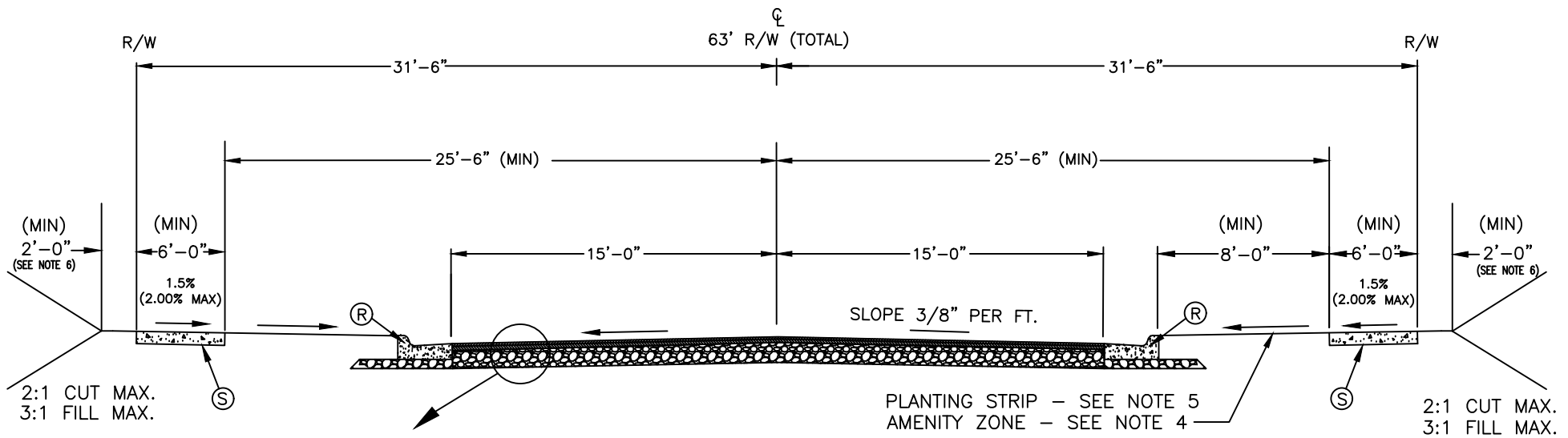

EITHER OF THESE PAVEMENT SECTIONS MAY BE USED:

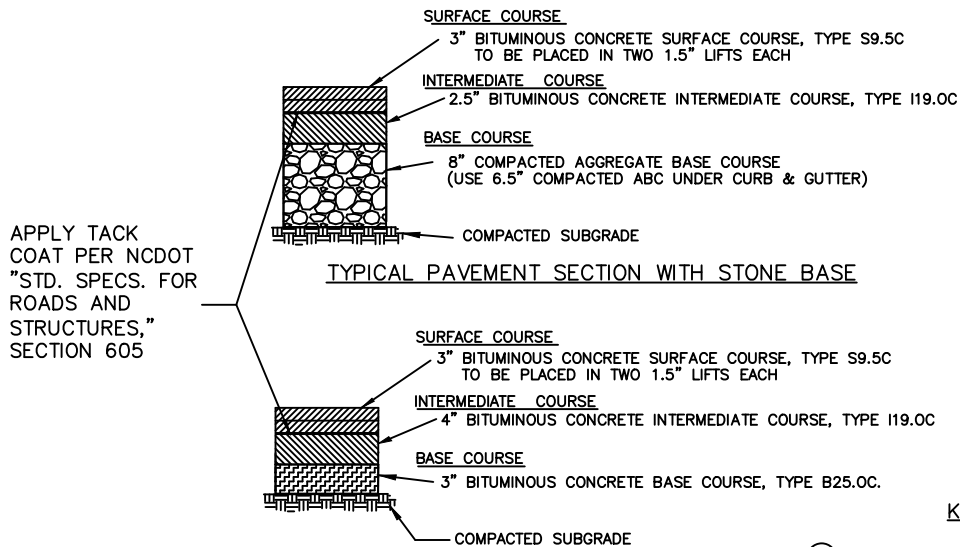

TYPICAL FULL-DEPTH ASPHALT PAVEMENT SECTION

- KEY**
- (R) 2'-6" STANDARD CURB AND GUTTER
 - (S) 4" CONCRETE SIDEWALK

NOTES:

1. USE OF VALLEY GUTTER IS PROHIBITED.
2. DEVELOPER MAY SUBMIT AN ALTERNATIVE PAVEMENT DESIGN TO CITY.
3. AN ALTERNATIVE PAVEMENT DESIGN MAY BE REQUIRED BY CDOT/NCDOT BASED ON SPECIFIC TRAFFIC PARAMETERS.
4. IF AMENITY ZONE IS AUTHORIZED IN PLACE OF PLANTING STRIP, CONCRETE SHALL BE 4" THICK AND CROSS SLOPE SHALL BE 1.5% (2% MAX).
5. PLANTING STRIP ADJACENT TO SIDEWALK SHALL BE GRADED TO 1/4" PER FOOT (MIN.) UP TO 1 1/4" PER FOOT (MAX.), EXCEPT WHERE EXCESSIVE NATURAL GRADES MAKE THIS REQUIREMENT IMPRACTICAL. IN SUCH CASES, CDOT MAY AUTHORIZE A SUITABLE GRADE.
6. 2' BUFFER CAN BE SUE OR ADDITIONAL R/W
7. IF USED IN ETJ, FULL-DEPTH ASPHALT PAVEMENT SECTION REQUIRED.

NOT TO SCALE



CITY OF CHARLOTTE
LAND DEVELOPMENT STANDARDS
 INCLUDES CHARLOTTE ETJ

LOCAL INDUSTRIAL STREET
 TYPICAL SECTION

STD. NO.	REV.
U-06	23

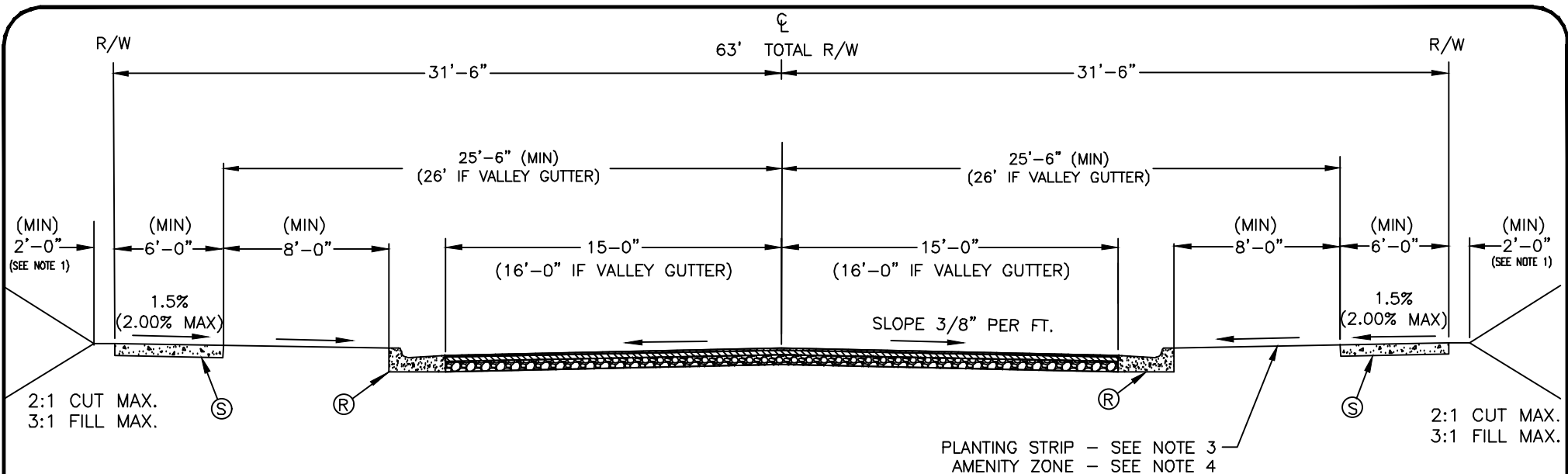

SURFACE COURSE

1" S9.5B

FINAL LIFT TO BE APPLIED UPON MEETING ONE OF THE FOLLOWING CONDITIONS:

- 1) 75% DEVELOPMENT OCCUPANCY,
- 2) 1 YEAR FROM INTERMEDIATE COURSE PLACEMENT,
- 3) FOR ETJ STREETS, FINAL 1" MAY BE PLACED WHEN APPROVED BY NCDOT.

INTERMEDIATE COURSE

1 1/2" S9.5C OR S9.5B

BASE COURSE

8" COMPACTED AGGREGATE BASE COURSE, OR 4" BCBC TYPE B25.0C. SHOULD ENTIRE DEVELOPMENT HAVE A CBR OF 6 OR GREATER, THEN AN ALTERNATIVE BASE COURSE PAVEMENT DESIGN MAY BE SUBMITTED TO THE CITY FOR APPROVAL.

SUBGRADE

COMPACTED SUBGRADE (SEE SECTION 1.A.18)

APPLY TACK COAT PER NCDOT "STD. SPECS. FOR ROADS AND STRUCTURES SECTION 605

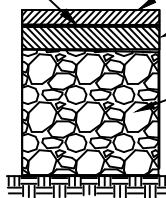

NOTES:

1. 2' BUFFER CAN BE SUE OR ADDITIONAL R/W.
2. AN ALTERNATIVE PAVEMENT SECTION DESIGN MAY BE REQUIRED BY CDOT/NCDOT BASED ON SPECIFIC TRAFFIC PARAMETERS
3. PLANTING STRIP ADJACENT TO SIDEWALK SHALL BE GRADED TO 1/4" PER FOOT (MIN.) UP TO 1 1/4" PER FOOT (MAX.), EXCEPT WHERE EXCESSIVE NATURAL GRADES MAKE THIS REQUIREMENT IMPRACTICAL. IN SUCH CASES, CDOT MAY AUTHORIZE A SUITABLE GRADE.
4. IF AMENITY ZONE IS AUTHORIZED IN PLACE OF PLANTING STRIP, CONCRETE SHALL BE 4" THICK AND CROSS SLOPE SHALL BE 1.5% (2% MAX).

TYPICAL PAVEMENT SECTION

KEY

- (R) 2'-6" STANDARD CURB AND GUTTER OR 2'-0" VALLEY GUTTER
- (S) 4" CONCRETE SIDEWALK

NOT TO SCALE



CITY OF CHARLOTTE
 LAND DEVELOPMENT STANDARDS
 INCLUDES CHARLOTTE ETJ

LOCAL COLLECTOR STREET
 TYPICAL SECTION (6' SIDEWALK)

STD. NO.	REV.
U-07A	23

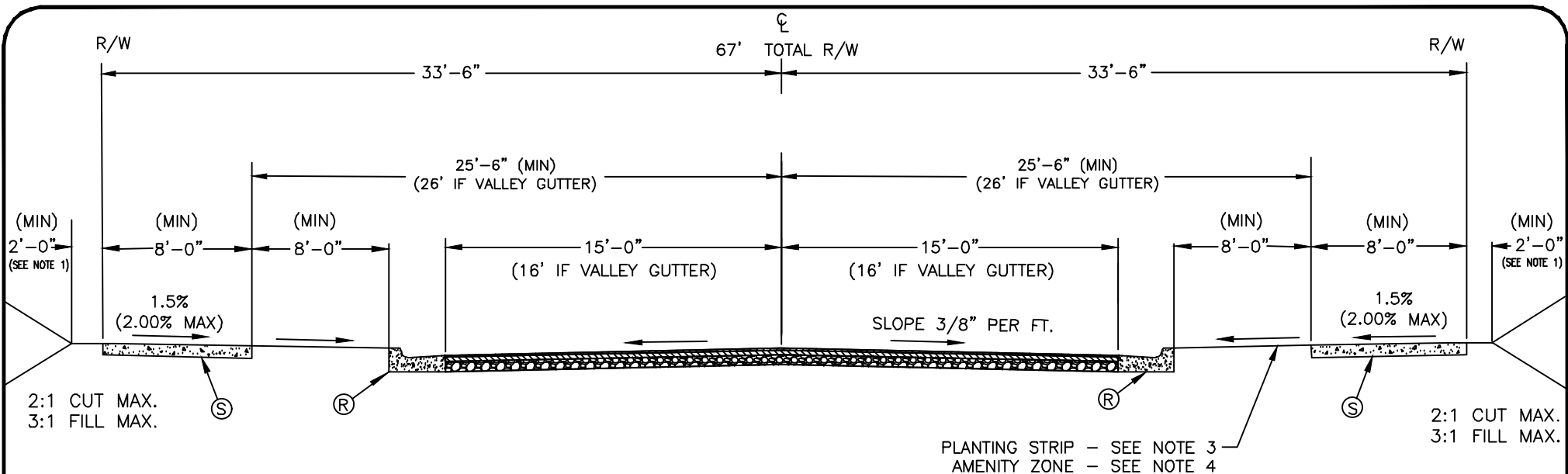

SURFACE COURSE
1" S9.5B

FINAL LIFT TO BE APPLIED UPON MEETING ONE OF THE FOLLOWING CONDITIONS:
 1) 75% DEVELOPMENT OCCUPANCY,
 2) 1 YEAR FROM INTERMEDIATE COURSE PLACEMENT,
 3) FOR ETJ STREETS, FINAL 1" MAY BE PLACED WHEN APPROVED BY NCDOT.

INTERMEDIATE COURSE
1 1/2" S9.5C OR S9.5B

BASE COURSE

8" COMPACTED AGGREGATE BASE COURSE, OR 4" BCBC TYPE B25.0C. SHOULD ENTIRE DEVELOPMENT HAVE A CBR OF 6 OR GREATER, THEN AN ALTERNATIVE BASE COURSE PAVEMENT DESIGN MAY BE SUBMITTED TO THE CITY FOR APPROVAL.

SUBGRADE

COMPACTED SUBGRADE (SEE SECTION 1.A.18)

APPLY TACK COAT PER NCDOT "STD. SPECS. FOR ROADS AND STRUCTURES 605

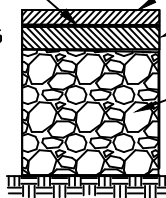

TYPICAL PAVEMENT SECTION

NOTES:

1. 2' BUFFER CAN BE SUE OR ADDITIONAL R/W.
2. AN ALTERNATIVE PAVEMENT SECTION DESIGN MAY BE REQUIRED BY CDOT/NCDOT BASED ON SPECIFIC TRAFFIC PARAMETERS
3. PLANTING STRIP ADJACENT TO SIDEWALK SHALL BE GRADED TO 1/4" PER FOOT (MIN.) UP TO 1 1/4" PER FOOT (MAX.), EXCEPT WHERE EXCESSIVE NATURAL GRADES MAKE THIS REQUIREMENT IMPRACTICAL. IN SUCH CASES, CDOT MAY AUTHORIZE A SUITABLE GRADE.
4. IF AMENITY ZONE IS AUTHORIZED IN PLACE OF PLANTING STRIP, CONCRETE SHALL BE 4" THICK AND CROSS SLOPE SHALL BE 1.5% (2% MAX).

KEY

- (R) 2'-6" STANDARD CURB AND GUTTER OR 2'-0" VALLEY GUTTER
- (S) 4" CONCRETE SIDEWALK

NOT TO SCALE



CITY OF CHARLOTTE
LAND DEVELOPMENT STANDARDS
 INCLUDES CHARLOTTE ETJ

LOCAL COLLECTOR STREET
TYPICAL SECTION (8' SIDEWALK)

STD. NO.	REV.
U-07B	23