

**STREET NAME SIGN
POST INSTALLATION**

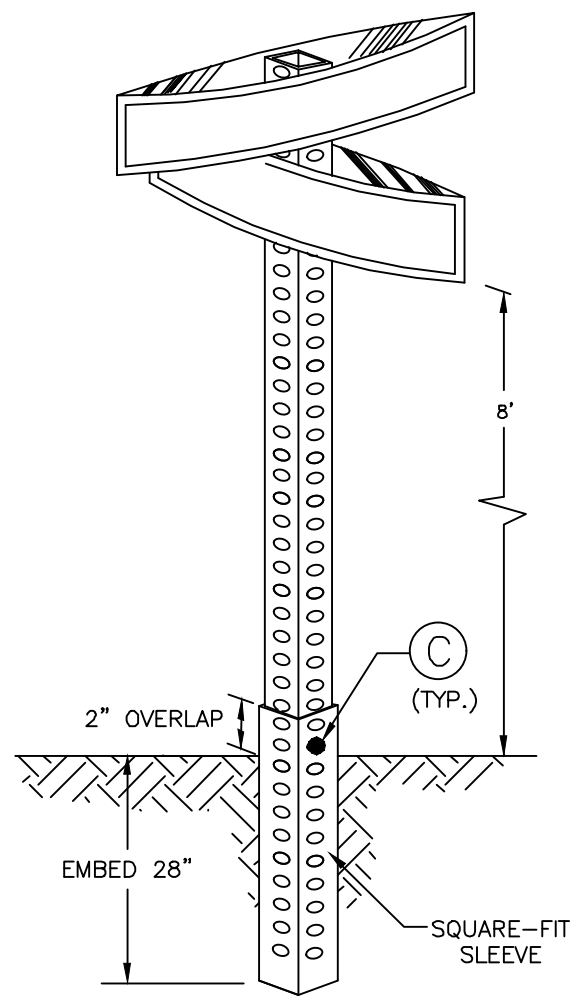

KEY TO FASTENERS:

- (A) #10-24 x 3/4" HEX HEAD MACHINE, ZINC- DEAD END
#10-24 FLANGE NUT, ZINC- DEAD END
- (B) 5/16" #16 X 3" CARRIAGE BOLT, ZINC
5/16" #16 HEX NUT, STEEL
- (C) 5/16" #16 X 2-3/4" CORNER BOLT (BREAKAWAY), ZINC
5/16" #16 HEX NUT, STEEL

NOTES:

1. POST SHALL BE 14-GAUGE GALVANIZED STEEL, QUIK-PUNCH, 7/16" HOLES, 1" ON CENTER, ALIGNED ON ALL SIDES, AND 2" SQUARE, 10 FEET IN LENGTH.
2. THE SLEEVE SHALL BE 12-GAUGE GALVANIZED STEEL, 7/16" HOLES, 1" ON CENTER, ALIGNED ON ALL SIDES, AND 2.25" SQUARE, 30" IN LENGTH.

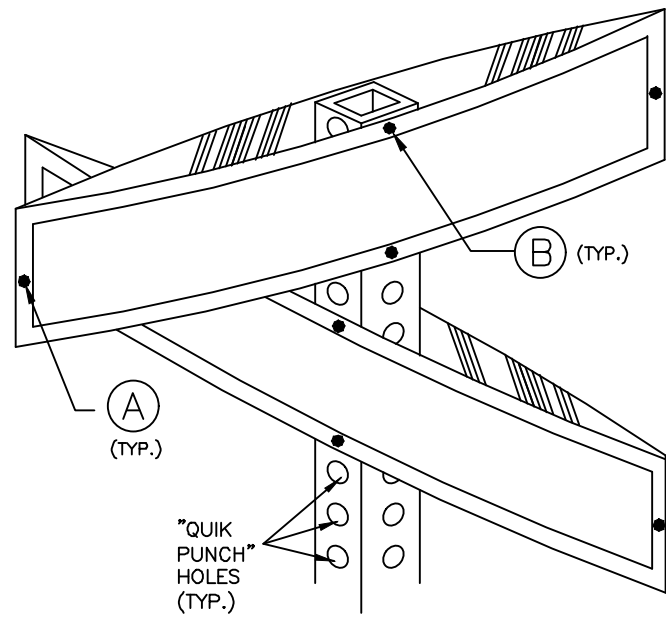

NOT TO SCALE



CITY OF CHARLOTTE
LAND DEVELOPMENT STANDARDS
INCLUDES CHARLOTTE ETJ

STREET NAME SIGN

STD. NO.	REV.
50.05A	23