

NOTES:

1. 4 1/2" X 9" X 60mm PAVERS FOR SIDEWALKS
2. 4 1/2" X 9" X 80mm PAVERS FOR DRIVEWAYS
3. THE BASE SLAB ELEVATION MAY HAVE TO BE ADJUSTED BY GRINDING AND/OR WITH MORTAR FILL TO PROVIDE A UNIFORM SAND LAYING COURSE THICKNESS OF ONE INCH
4. SIDEWALKS SHALL HAVE A DESIRED CROSS SLOPE OF 1.5% (2.00% MAXIMUM)
5. VERTICAL SURFACE DISCONTINUITIES SHOULD BE MINIMIZED AND SHALL NOT EXCEED 1/4"

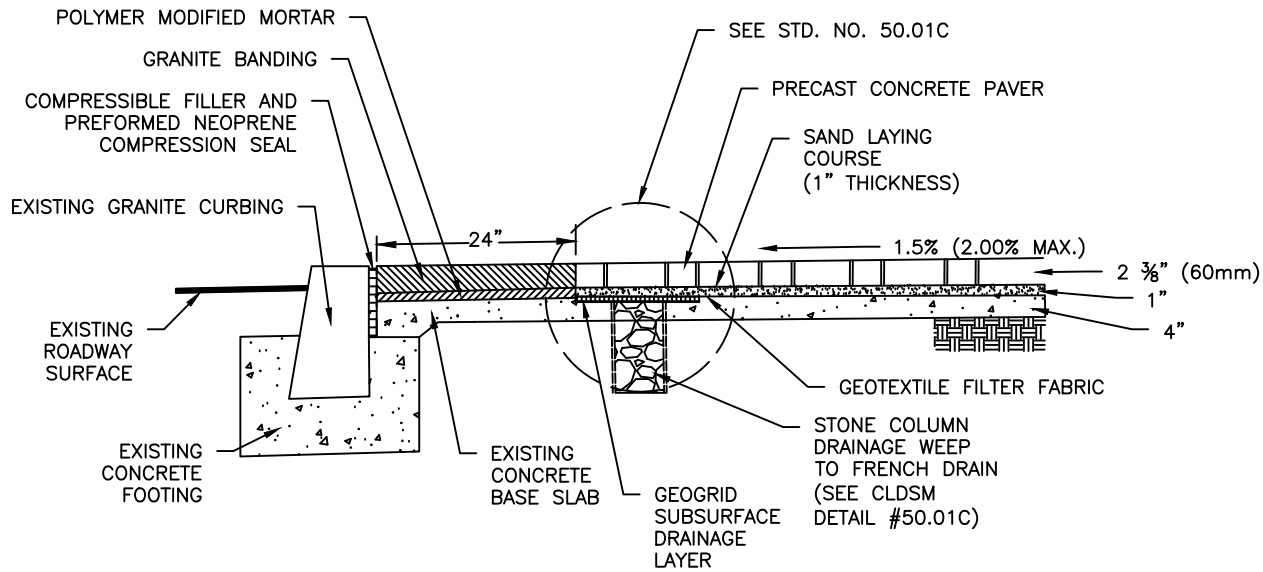

TYPICAL PAVER SIDEWALK SECTION WITH CONCRETE SUBSLAB BASE

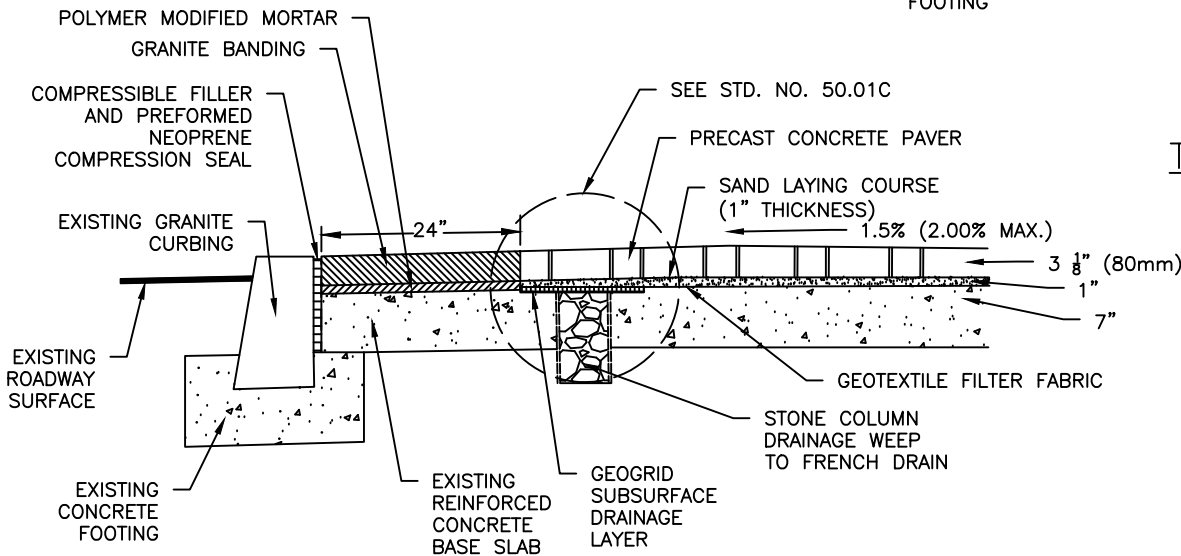

TYPICAL PAVER DRIVEWAY SECTION WITH CONCRETE SUBSLAB BASE

NOT TO SCALE



CITY OF CHARLOTTE
LAND DEVELOPMENT STANDARDS
 INCLUDES CHARLOTTE ETJ

PRECAST CONCRETE PAVERS
 FOR UPTOWN STREETScape

STD. NO.	REV.
50.01B	23