

LEGEND

BOARDING AND ALIGHTING AREA 

BUS SIGN 

CONCRETE 4" THICK 

TRASH RECEPTACLE 

NOTES

1. DIMENSIONS REPRESENT MINIMUM STANDARDS, VARIATIONS MUST BE APPROVED THROUGH CATS AND CDOT PROJECT MANAGER.
2. WIDTH OF EXISTING SIDEWALK PLUS PLANTING STRIP WIDTH MUST EQUAL 8' WIDE. IF WIDTH IS LESS THAN 8', EXISTING SIDEWALK MUST BE REPLACED WITH WIDER SIDEWALK TO OBTAIN 8' WIDTH.
3. SEE SHEET NO. 60.07A, 60.07B, AND 60.07C FOR ADDITIONAL DETAILS AND NOTES.

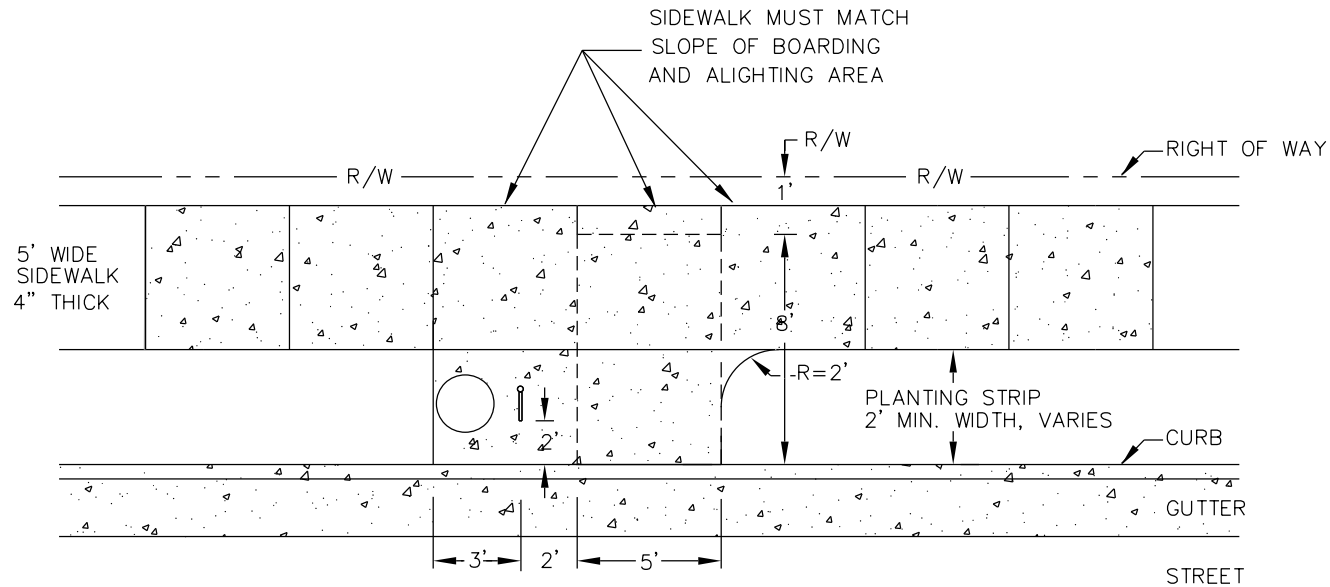

PLAN VIEW
NTS

REVISIONS

NO.	DATE	DESCRIPTION

APPROVED DATE _____



BUS STOP WITH PLANTING STRIP, MINIMUM WIDTH

STD. NO.	REV.
60.01A	

LEGEND

BOARDING AND ALIGHTING AREA 

BUS SIGN 

EXISTING CONCRETE 

CONCRETE SLAB 6" THICK 

TRASH RECEPTACLE 

NOTES

1. DIMENSIONS REPRESENT MINIMUM STANDARDS. VARIATIONS MUST BE APPROVED THROUGH CATS AND CDOT PROJECT MANAGER.
2. IN AREAS OF RESTRICTED R/W, SIDEWALK AND PAD MAY BE REDUCED TO A MINIMUM OF 8'. THE 6" CONCRETE SLAB AND THE EXISTING SIDEWALK ADJACENT TO NEW BOARDING AND ALIGHTING AREA MUST MATCH SLOPE (1.5%, MAX. 2%) OF BOARDING AND ALIGHTING AREA.
3. SEE SHEET NO. 60.07A, 60.07B AND 60.07C FOR ADDITIONAL DETAILS AND NOTES.

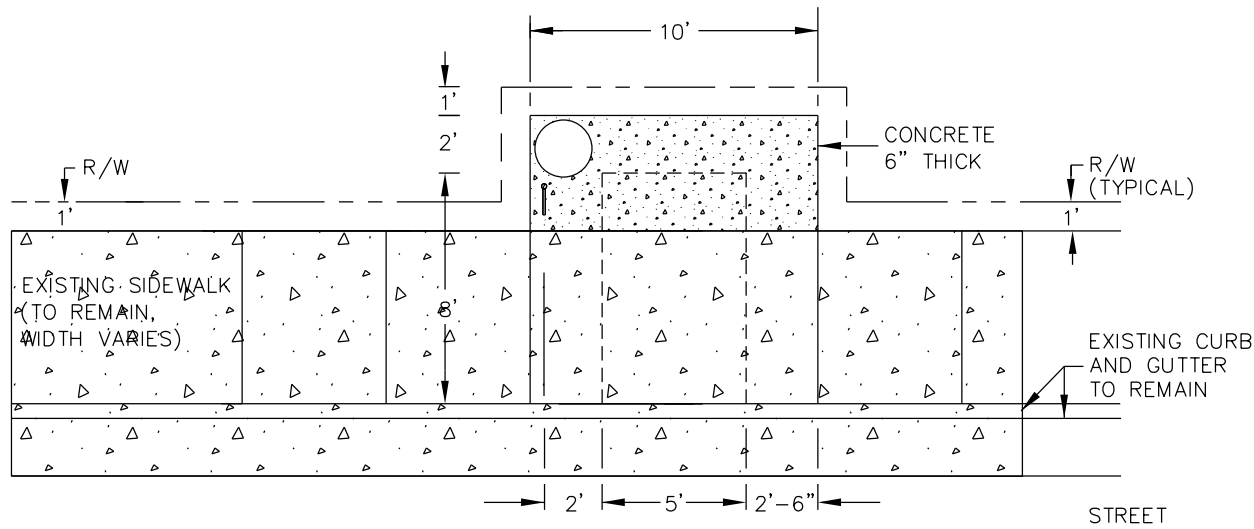

PLAN VIEW
NTS

REVISIONS

NO.	DATE	DESCRIPTION

APPROVED DATE _____





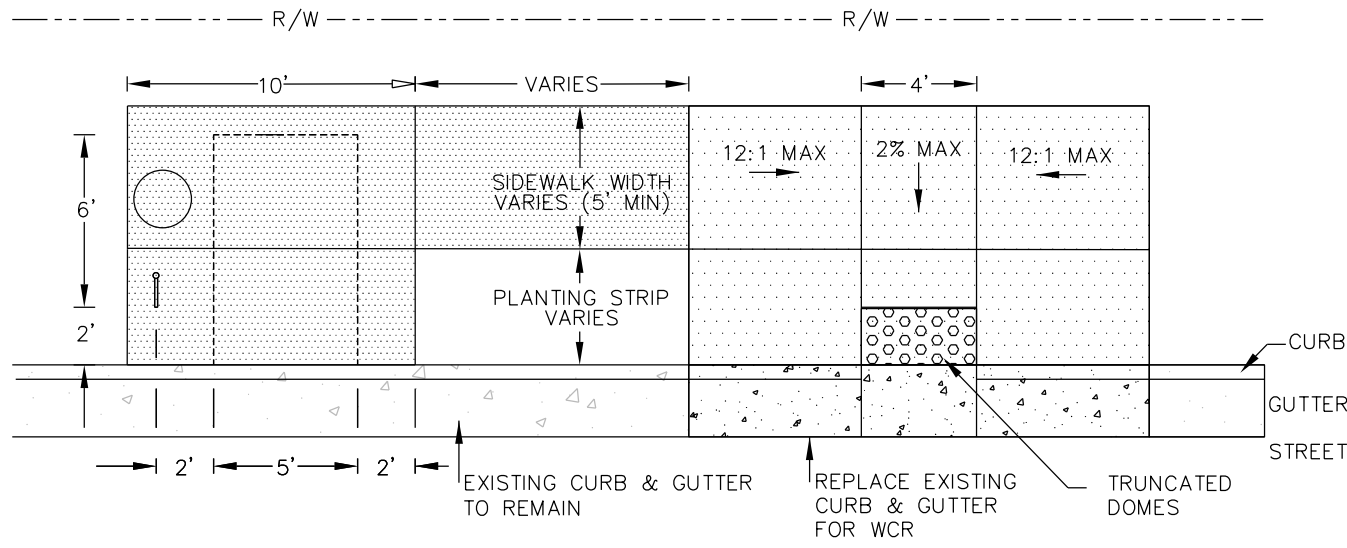

**BUS STOP ONLY
WITHOUT PLANTING STRIP**

STD. NO.	REV.
60.01B	

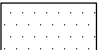

PLAN VIEW
NTS

LEGEND

- BOARDING AND ALIGHTING AREA 
- BUS SIGN 
- CONCRETE SLAB AND SIDEWALK 4" THICK 
- NEW CONCRETE WCR 6" THICK 
- TRASH RECEPTACLE 

NOTES:

1. DIMENSIONS REPRESENT MINIMUM STANDARDS, VARIATIONS MUST BE APPROVED THROUGH CATS AND CDOT PROJECT MANAGER.
2. SEE SHEETS NO. 60.07A, 60.07B AND 60.07C FOR ADDITIONAL DETAILS AND NOTES.
3. WIDTH OF SIDEWALK PLUS PLANTING STRIP MUST EQUAL 8' MIN. TO PROVIDE BOARDING AND ALIGHTING AREA
4. RAMP MAY BE INSTALLED ON EITHER SIDE OF THE BUS PAD.
5. RECEIVING RAMP ACROSS THE STREET IS PREFERRED BUT NOT REQUIRED.

REVISIONS

NO.	DATE	DESCRIPTION

APPROVED DATE _____





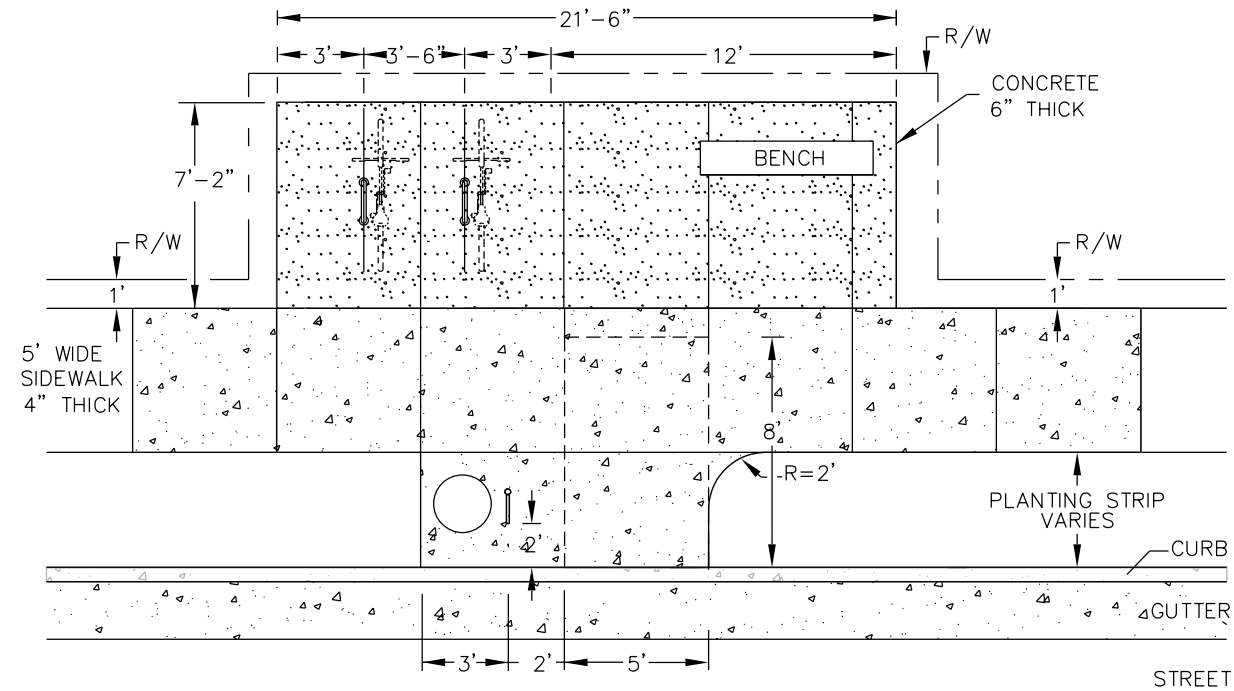

BUS STOP WITH RAMP AND PLANTING STRIP WITHOUT SIDEWALK

STD. NO.	REV.
60.01C	

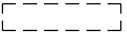
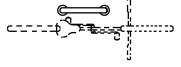

PLAN VIEW
NTS

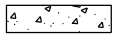
LEGEND

- BOARDING AND ALIGHTING AREA 
- BIKE RACK 
- BUS SIGN 
- CONCRETE SLAB 4" THICK 
- CONCRETE SLAB 6" THICK 
- TRASH RECEPTACLE 

NOTES:

1. DIMENSIONS REPRESENT MINIMUM STANDARDS. VARIATIONS MUST BE APPROVED THROUGH CATS AND CDOT PROJECT MANAGER.
2. WIDTH OF SIDEWALK PLUS PLANTING STRIP WIDTH MUST EQUAL 8' WIDE. IF WIDTH IS LESS THAN 8', SIDEWALK MUST BE REPLACED WITH WIDER SIDEWALK TO OBTAIN 8' WIDTH.
3. SEE SHEET NO. 60.07A, 60.07B AND 60.07C FOR ADDITIONAL DETAILS AND NOTES.

REVISIONS

NO.	DATE	DESCRIPTION

APPROVED DATE _____







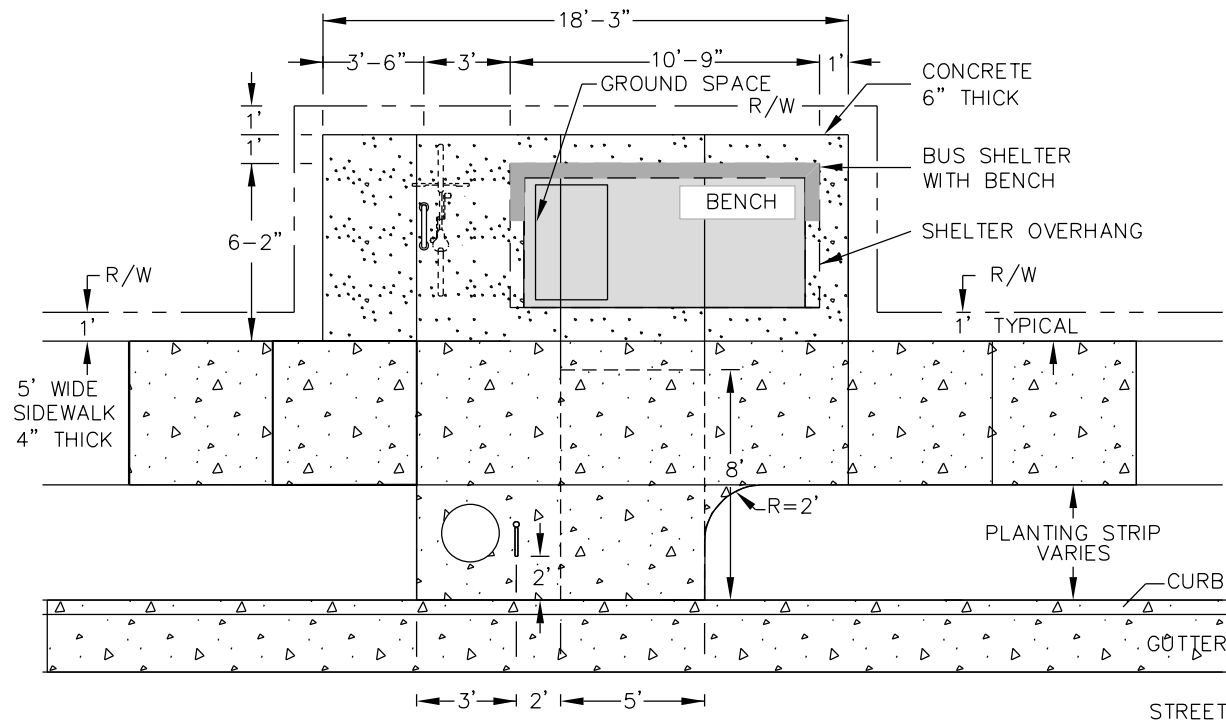

**BUS STOP AND BENCH
WITH PLANTING STRIP**

STD. NO.	REV.
60.02A	

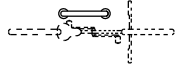

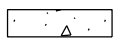
PLAN VIEW
NTS

LEGEND

- BOARDING AND ALIGHTING AREA [---]
- BIKE RACK 
- BUS SIGN 
- CONCRETE SLAB 4" THICK 
- CONCRETE SLAB 6" THICK 
- SHELTER 
- TRASH RECEPTACLE 

NOTES

1. DIMENSIONS REPRESENT MINIMUM STANDARDS, VARIATIONS MUST BE APPROVED THROUGH CATS AND CDOT PROJECT MANAGER.
2. WIDTH OF EXISTING SIDEWALK MUST PLUS PLANTING STRIP MUST EQUAL 8' WIDE. IF WIDTH IS LESS THAN 8', EXISTING SIDEWALK MUST BE REPLACED WITH WIDER SIDEWALK TO OBTAIN 8' WIDTH.
3. SEE SHEET NO. 60.07A, 60.07B AND 60.07C FOR ADDITIONAL DETAILS AND NOTES.

APPROVED DATE _____

REVISIONS		
NO.	DATE	DESCRIPTION



BUS STOP WITH 5' X 10' SHELTER AND PLANTING STRIP

STD. NO.	REV.
60.03A	

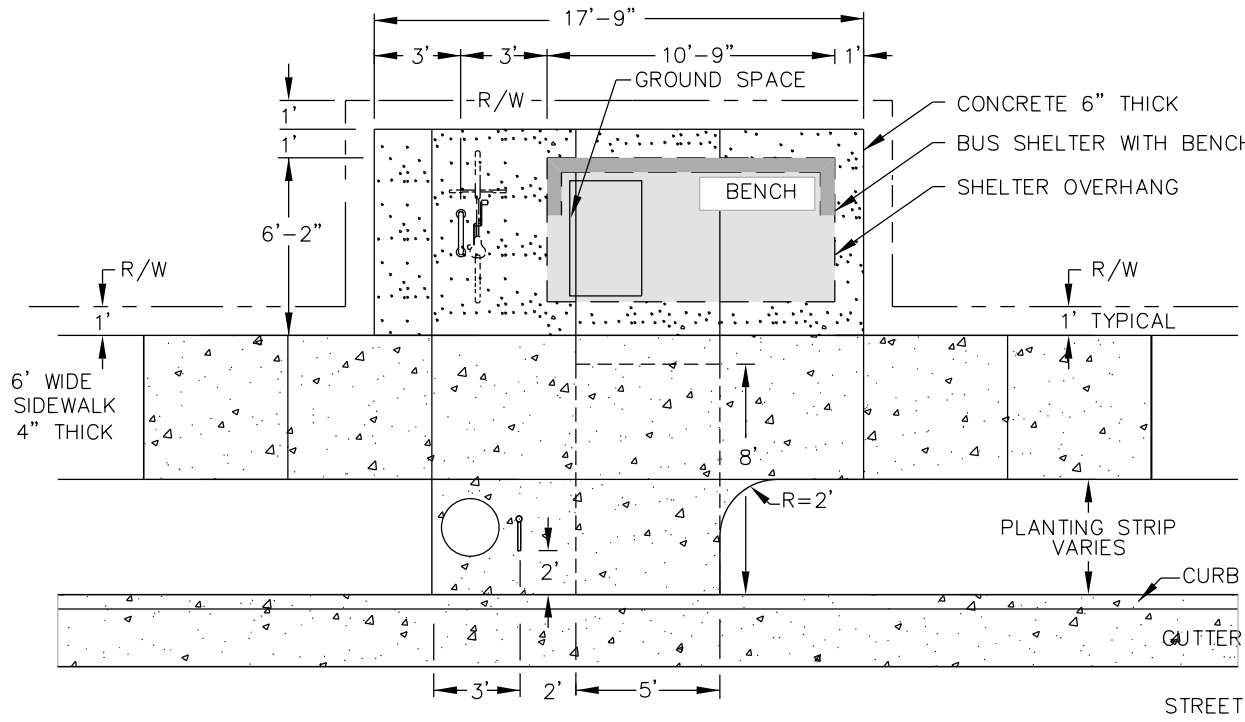

PLAN VIEW
NTS

LEGEND

- BOARDING AND ALIGHTING AREA
- BIKE RACK
- BUS SIGN
- CONCRETE SLAB 4\" THICK
- CONCRETE SLAB 6\" THICK
- SHELTER
- TRASH RECEPTACLE

NOTES

1. DIMENSIONS REPRESENT MINIMUM STANDARDS, VARIATIONS MUST BE APPROVED THROUGH CATS AND CDOT PROJECT MANAGER.
2. WIDTH OF EXISTING SIDEWALK PLUS PLANTING STRIP MUST EQUAL 8' WIDE. IF WIDTH IS LESS THAN 8', EXISTING SIDEWALK MUST BE REPLACED WITH WIDER SIDEWALK TO OBTAIN 8' WIDTH.
3. SEE SHEET NO. 60.07A, 60.07B AND 60.07C FOR ADDITIONAL DETAILS AND NOTES.

REVISIONS

NO.	DATE	DESCRIPTION

APPROVED DATE _____





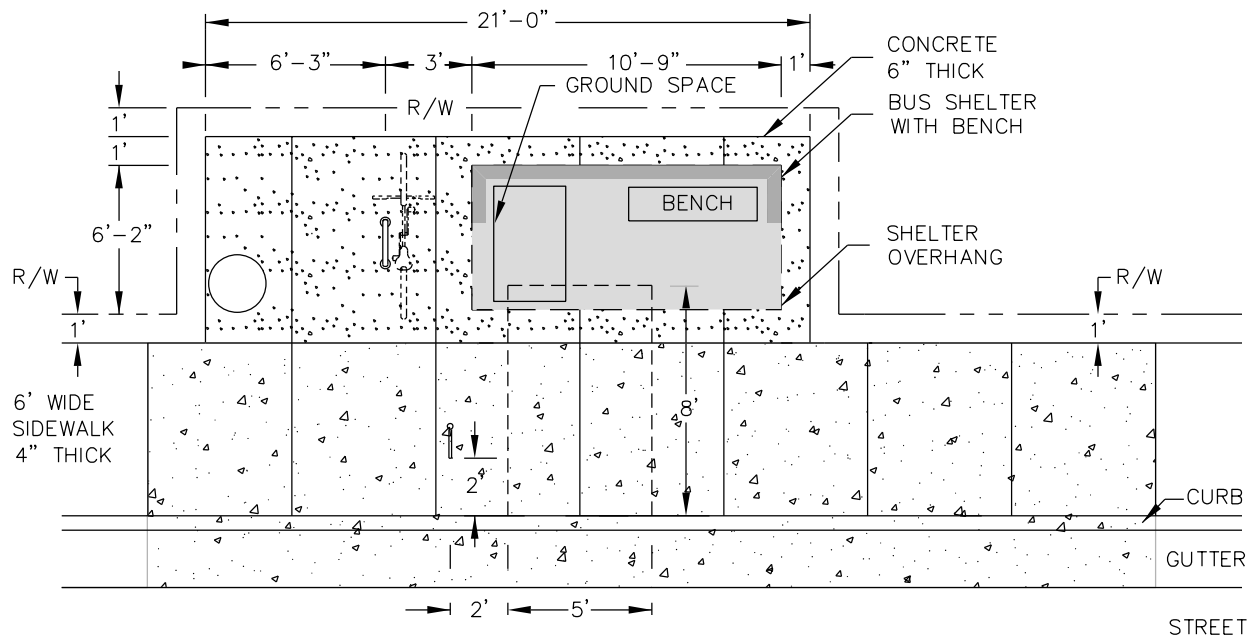

**BUS STOP WITH 5' x 10' SHELTER
AND PLANTING STRIP**

STD. NO.	REV.
60.03B	

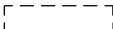
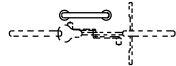

PLAN VIEW
NTS

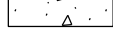
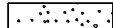
LEGEND

- BOARDING AND ALIGHTING AREA 
- BIKE RACK 
- BUS SIGN 
- CONCRETE SLAB 4" THICK 
- CONCRETE SLAB 6" THICK 
- SHELTER 
- TRASH RECEPTACLE 

NOTES

1. DIMENSIONS REPRESENT MINIMUM STANDARDS, VARIATIONS MUST BE APPROVED THROUGH CATS AND CDOT PROJECT MANAGER.
2. WIDTH OF SIDEWALK PLUS PLANTING STRIP WIDTH MUST EQUAL 8' WIDE. IF WIDTH IS LESS THAN 8', EXISTING SIDEWALK MUST BE REPLACED WITH WIDER SIDEWALK TO OBTAIN 8' WIDTH.
3. SEE SHEET NO. 60.07A, 60.07B AND 60.07C FOR ADDITIONAL DETAILS AND NOTES.

REVISIONS

NO.	DATE	DESCRIPTION

APPROVED DATE _____



**BUS STOP WITH 5' x 10' SHELTER
WITHOUT PLANTING STRIP**

STD. NO.	REV.
60.03C	

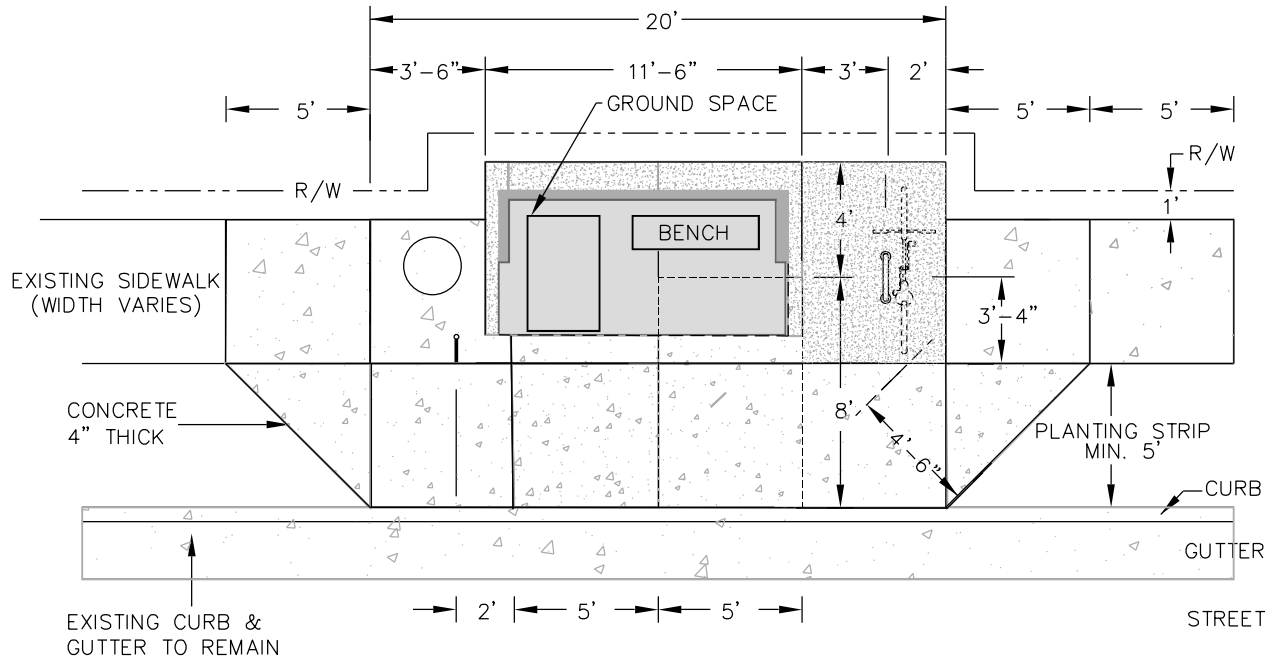

PLAN VIEW
NTS

LEGEND

- BOARDING AND ALIGHTING AREA
- BIKE RACK
- BUS SIGN
- CONCRETE SLAB 4" THICK
- CONCRETE SLAB 6" THICK
- SHELTER
- TRASH RECEPTACLE

NOTES

1. DIMENSIONS REPRESENT MINIMUM STANDARDS, VARIATIONS MUST BE APPROVED THROUGH CATS AND CDOT PROJECT MANAGER.
2. WIDTH OF EXISTING SIDEWALK PLUS PLANTING STRIP MUST EQUAL 8' WIDE. IF WIDTH IS LESS THAN 8', EXISTING SIDEWALK MUST BE REPLACED WITH WIDER SIDEWALK TO OBTAIN 8' WIDTH.
3. SEE SHEET NO. 60.07A, 60.07B AND 60.07C FOR ADDITIONAL DETAILS AND NOTES.

REVISIONS

NO.	DATE	DESCRIPTION

APPROVED DATE _____



**BUS STOP WITH 5' X 10' SHELTER
WITH PLANTING STRIP**



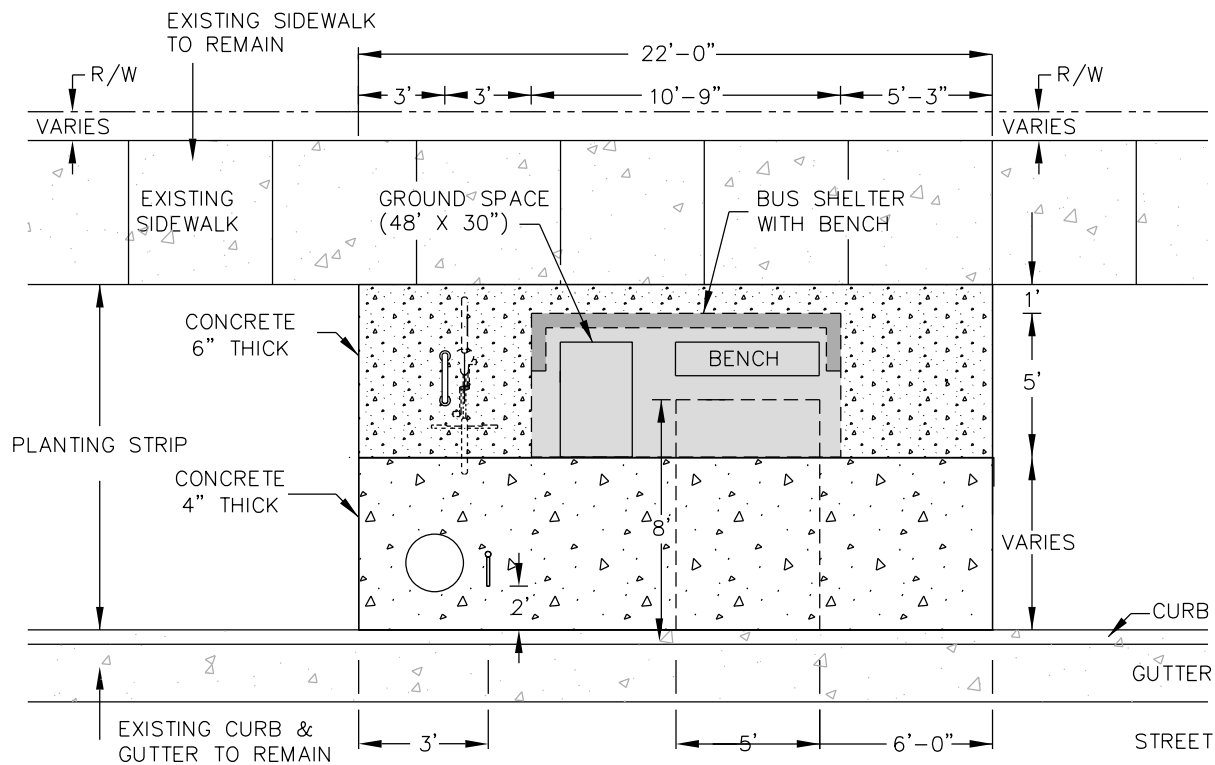

STD. NO.	REV.
60.03D	

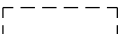
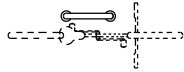

PLAN VIEW

NTS

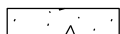
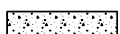
LEGEND

- BOARDING AND ALIGHTING AREA 
- BIKE RACK 
- BUS SIGN 
- CONCRETE SLAB 4" THICK 
- CONCRETE SLAB 6" THICK 
- SHELTER 
- TRASH RECEPTACLE 

NOTES

1. DIMENSIONS REPRESENT MINIMUM STANDARDS. VARIATIONS MUST BE APPROVED THROUGH CATS AND CDOT PROJECT MANAGER.
2. MINIMUM PLANTING STRIP WIDTH REQUIRED IS 12'. CLEAR RECOVERY ZONES MAY REQUIRE GREATER PLANTING STRIP WIDTHS ON NCDOT MAINTAINED STREETS.
3. SEE SHEET NO. 60.07A, 60.07B AND 60.07C FOR ADDITIONAL DETAILS AND NOTES.

APPROVED DATE _____

REVISIONS

NO.	DATE	DESCRIPTION





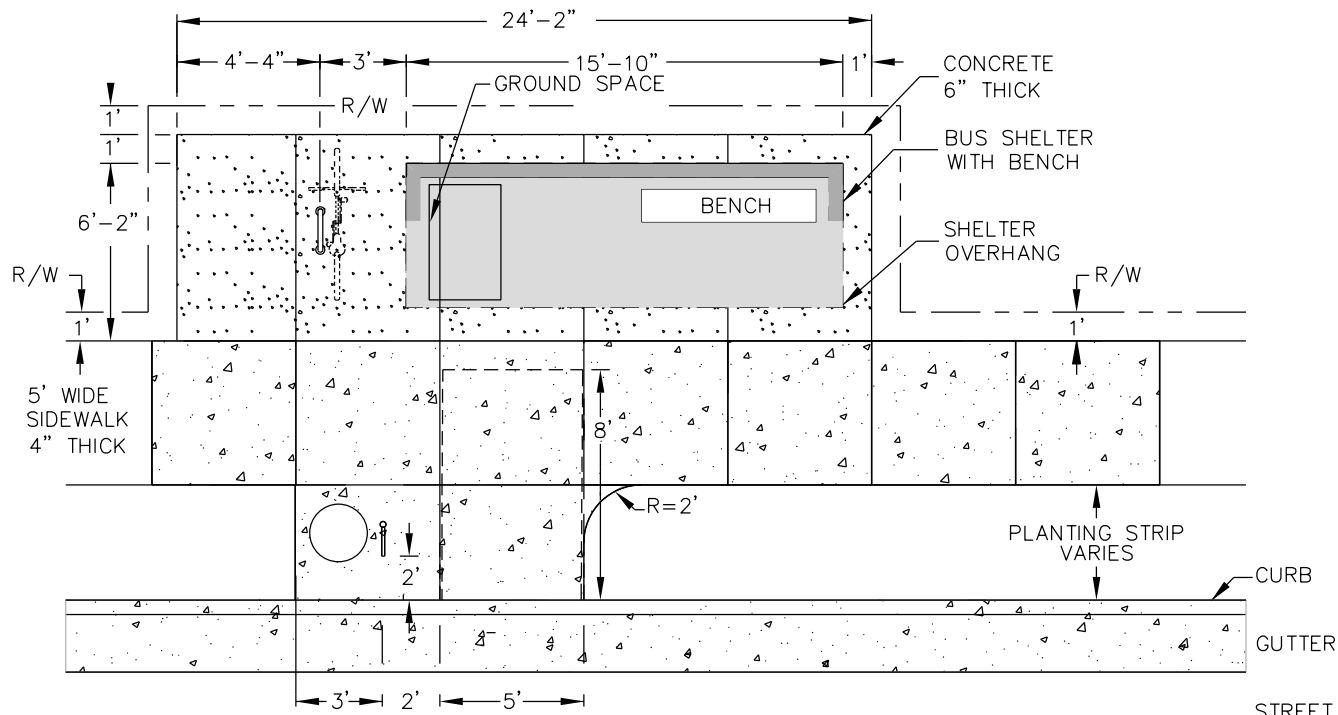

BUS STOP WITH 5' X 10' SHELTER AND PLANTING STRIP

STD. NO.	REV.
60.03E	

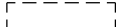
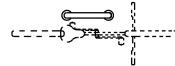

PLAN VIEW
NTS

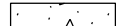
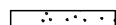
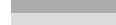
LEGEND

- BOARDING AND ALIGHTING AREA 
- BIKE RACK 
- BUS SIGN 
- CONCRETE SLAB 4" THICK 
- CONCRETE SLAB 6" THICK 
- SHELTER 
- TRASH RECEPTACLE 

NOTES

1. DIMENSIONS REPRESENT MINIMUM STANDARDS, VARIATIONS MUST BE APPROVED THROUGH CATS AND CDOT PROJECT MANAGER.
2. WIDTH OF SIDEWALK PLUS PLANTING STRIP WIDTH MUST EQUAL 8' WIDE. IF WIDTH IS LESS THAN 8', SIDEWALK MUST BE REPLACED WITH WIDER SIDEWALK TO OBTAIN 8' WIDTH.
3. SEE SHEET NO. 60.07A, 60.07B AND 60.07C FOR ADDITIONAL DETAILS AND NOTES.

REVISIONS

NO.	DATE	DESCRIPTION

APPROVED DATE _____





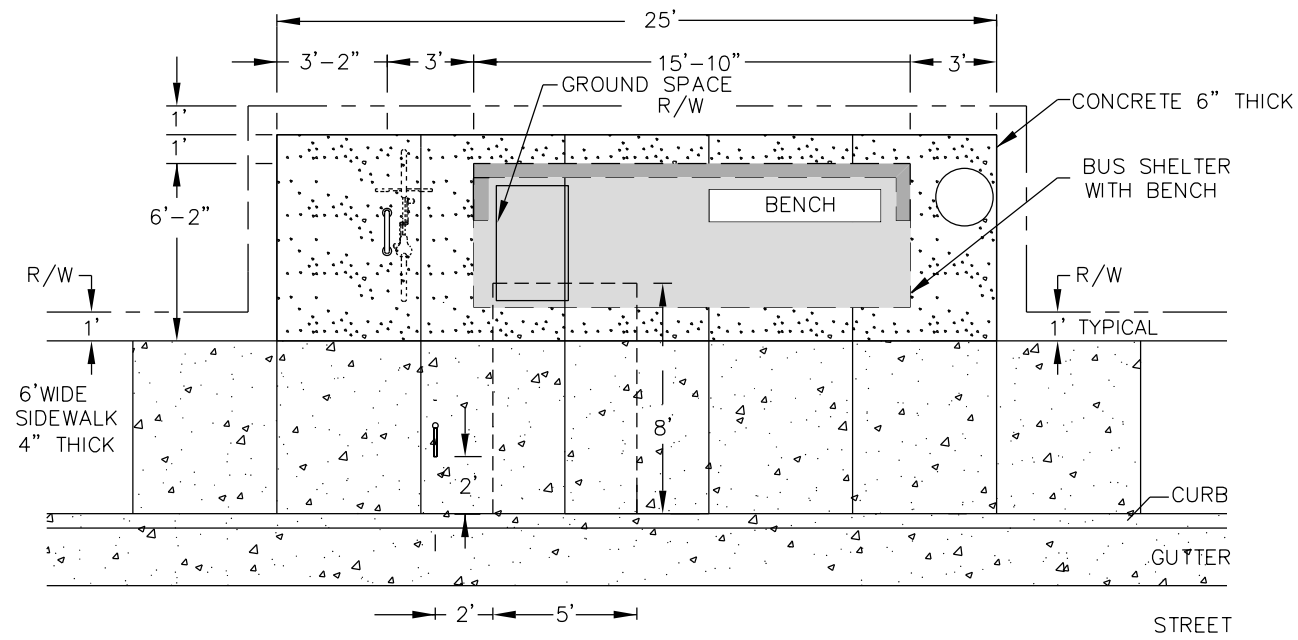

BUS STOP WITH 5' X 15' SHELTER AND PLANTING STRIP

STD. NO.	REV.
60.04A	

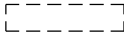
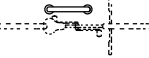

PLAN VIEW
NTS

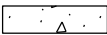
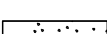
LEGEND

- BOARDING AND ALIGHTING AREA 
- BIKE RACK 
- BUS SIGN 
- CONCRETE SLAB 4" THICK 
- CONCRETE SLAB 6" THICK 
- SHELTER 
- TRASH RECEPTACLE 

NOTES

1. DIMENSIONS REPRESENT MINIMUM STANDARDS, VARIATIONS MUST BE APPROVED THROUGH CATS AND CDOT PROJECT MANAGER.
2. BOARDING AND ALIGHTING AREA MUST NOT OVERLAP GROUND SPACE BY 2'0" MAX. GROUND SPACE TO MATCH SLOPE OF BOARDING AND ALIGHTING AREA (1.5%, MAX. 2%).
3. SEE SHEET NO. 60.07A, 60.07B AND 60.07C FOR ADDITIONAL DETAILS AND NOTES.

REVISIONS

NO.	DATE	DESCRIPTION

APPROVED DATE _____





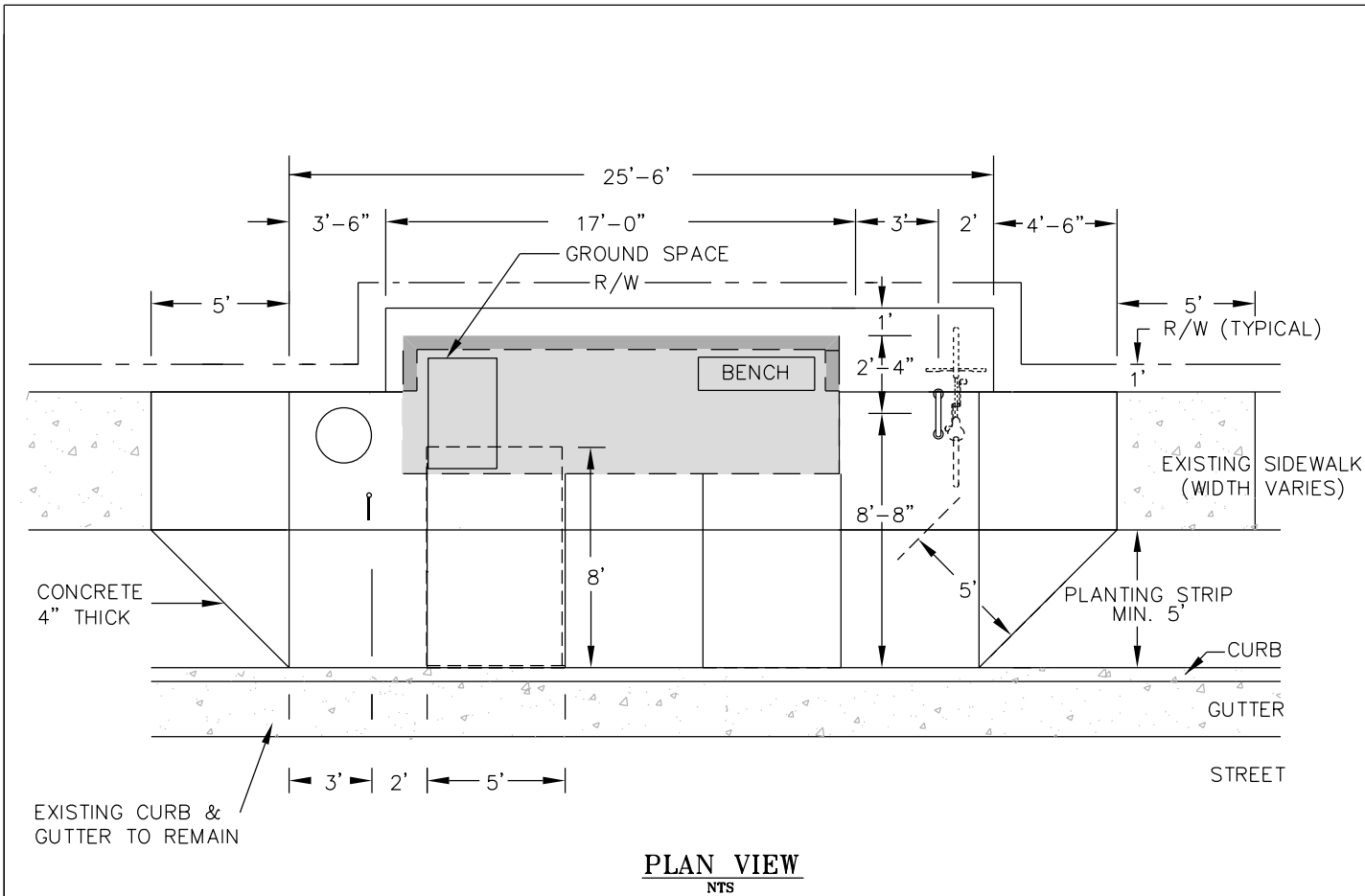

**BUS STOP WITH 5' X 15' SHELTER
WITHOUT PLANTING STRIP**

STD. NO.	REV.
60.04B	

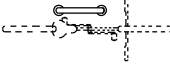

PLAN VIEW
NTS

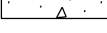
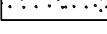
LEGEND

- BOARDING AND ALIGHTING AREA 
- BIKE RACK 
- BUS SIGN 
- CONCRETE SLAB 4" THICK 
- CONCRETE SLAB 6" THICK 
- SHELTER 
- TRASH RECEPTACLE 

NOTES

1. DIMENSIONS REPRESENT MINIMUM STANDARDS, VARIATIONS MUST BE APPROVED THROUGH CATS AND CDOT PROJECT MANAGER.
2. WIDTH OF EXISTING SIDEWALK MUST PLUS PLANTING STRIP MUST EQUAL 8' WIDE. IF WIDTH IS LESS THAN 8', EXISTING SIDEWALK MUST BE REPLACED WITH WIDER SIDEWALK TO OBTAIN 8' WIDTH.
3. SEE SHEET NO. 60.07A, 60.07B AND 60.07C FOR ADDITIONAL DETAILS AND NOTES.

REVISIONS

NO.	DATE	DESCRIPTION

APPROVED DATE _____





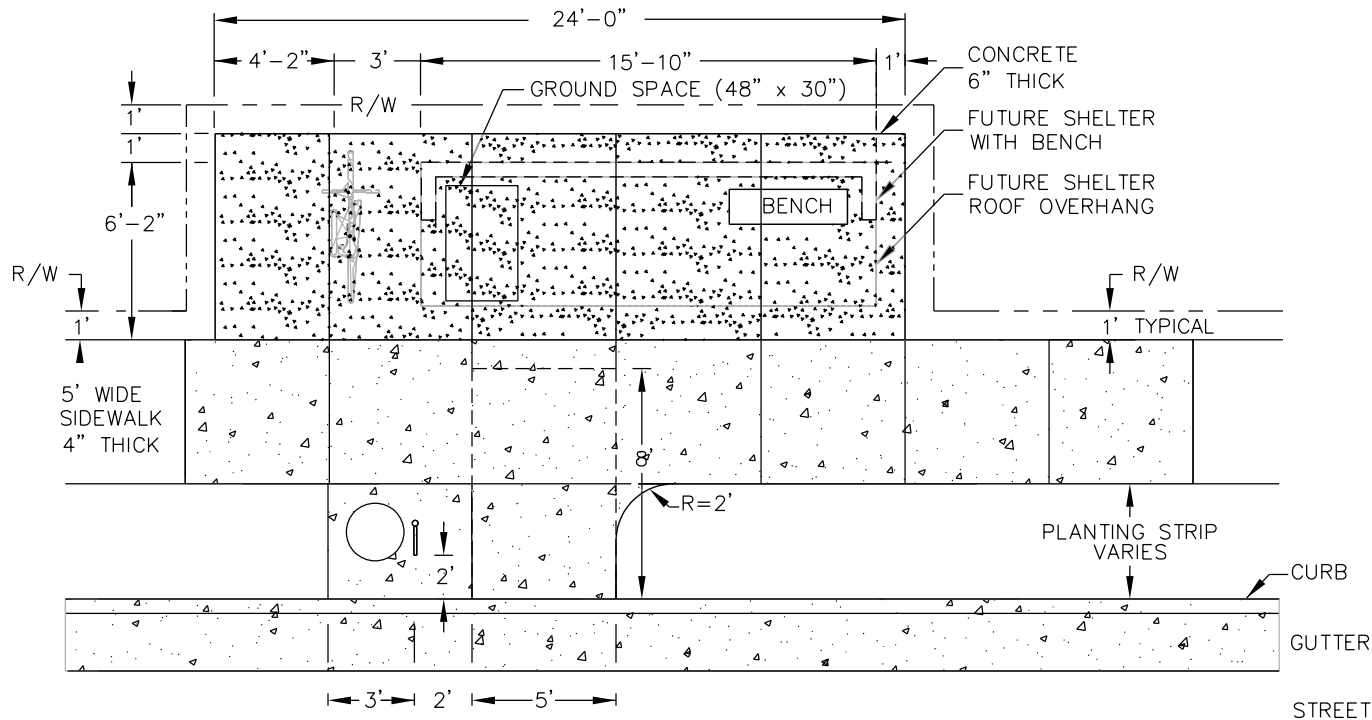

BUS STOP WITH 5' X 15' SHELTER WITH PLANTING STRIP

STD. NO.	REV.
60.04C	

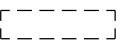
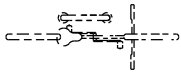

PLAN VIEW
NTS

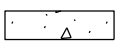
LEGEND

- BOARDING AND ALIGHTING AREA 
- FUTURE BIKE RACK 
- BUS SIGN 
- CONCRETE SLAB 4" THICK 
- CONCRETE SLAB 6" THICK 
- TRASH RECEPTACLE 

NOTES

1. DIMENSIONS REPRESENT MINIMUM STANDARDS, VARIATIONS MUST BE APPROVED THROUGH CATS AND CDOT PROJECT MANAGER.
2. WIDTH OF EXISTING SIDEWALK PLUS PLANTING STRIP MUST EQUAL 8' WIDE. IF WIDTH IS LESS THAN 8', EXISTING SIDEWALK MUST BE REPLACED WITH WIDER SIDEWALK TO OBTAIN 8' WIDTH.
3. SEE SHEET NO. 60.07A, 60.07B AND 60.07C FOR ADDITIONAL DETAILS AND NOTES.

REVISIONS

NO.	DATE	DESCRIPTION

APPROVED DATE _____





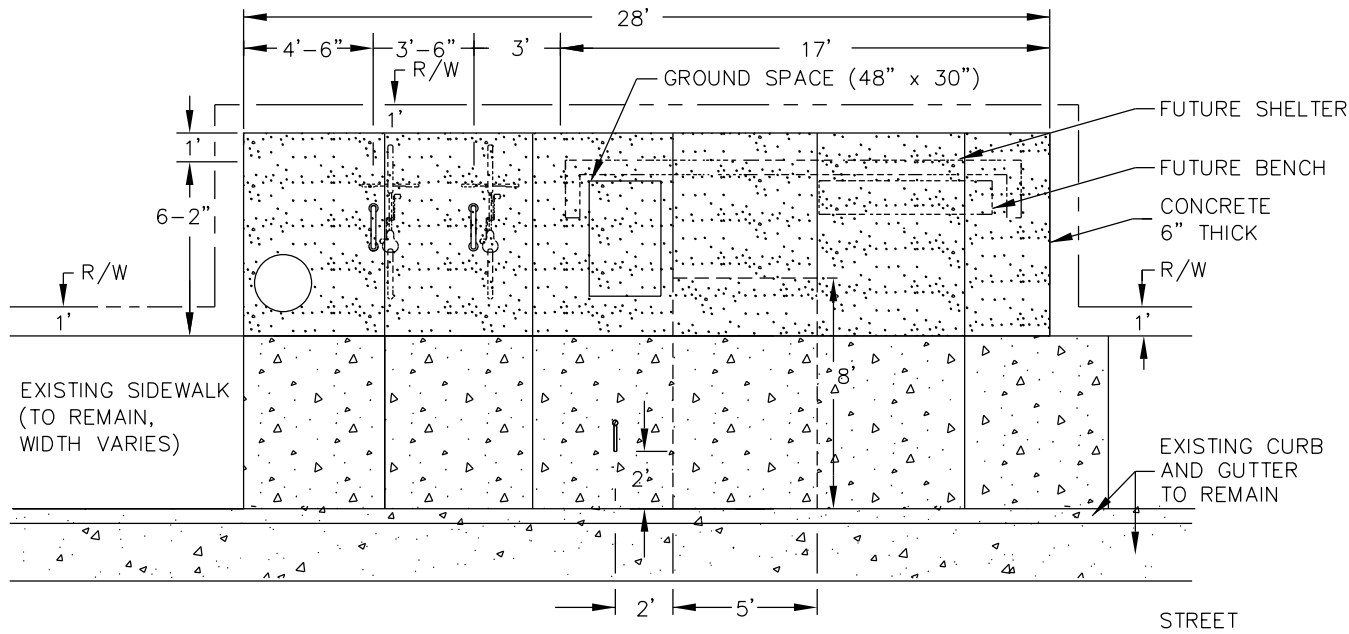

**BUS STOP WITH PLANTING STRIP
AND WITH FUTURE EXPANSION**

STD. NO.	REV.
60.05A	

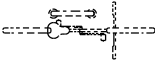

PLAN VIEW
NTS

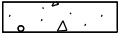
LEGEND

- BOARDING AND ALIGHTING AREA 
- FUTURE BIKE RACK 
- BUS SIGN 
- EXISTING CONCRETE 
- CONCRETE SLAB 6" THICK 
- TRASH RECEPTACLE 

NOTES

1. DIMENSIONS REPRESENT MINIMUM STANDARDS. VARIATIONS MUST BE APPROVED THROUGH CATS AND CDOT PROJECT MANAGER.
2. IN AREAS OF THE 6" CONCRETE SLAB, THE BOARDING AND ALIGHTING AREA, AND THE SIDEWALK ADJACENT TO NEW BOARDING AND ALIGHTING AREA MUST MATCH THE SLOPE (1.5%, MAX. 2%) OF BOARD AND ALIGHTING AREA.
3. SEE SHEET NO. 60.07A, 60.07B AND 60.07C FOR ADDITIONAL DETAILS AND NOTES.

REVISIONS

NO.	DATE	DESCRIPTION

APPROVED DATE _____



**BUS STOP WITHOUT PLANTING STRIP
WITH FUTURE EXPANSION**

STD. NO.	REV.
60.05B	

GENERAL NOTES:

1. A GROOVE JOINT 1" DEEP WITH 1/8" RADII SHALL BE REQUIRED IN THE CONCRETE SIDEWALK WITH JOINT SPACING EQUAL TO THE WIDTH OF SIDEWALK (MAX 6'). ONE 1/2" EXPANSION JOINT WILL BE REQUIRED AT NOT MORE THAN 45'. A SEALED 1/2" EXPANSION WILL BE REQUIRED WHERE SIDEWALK JOINS ANY RIGID STRUCTURE
2. ALL CONCRETE TO BE A MINIMUM 3,600 P.S.I. COMPRESSIVE STRENGTH AT 28 DAYS. CONCRETE SHALL BE 6" THICK FOR BENCH, BIKE RACKS, AND SHELTER PAD. CONCRETE SHALL BE 4" THICK FOR SIDEWALKS LESS THAN 7'-0" WIDE. CONCRETE SHALL BE 6" THICK FOR SIDEWALKS >= 10'-0" WIDE. SEE CLDSM STD. NO 10.42.
3. SIDEWALK AND PLANTING STRIP WIDTH VARIES DUE TO SITE LIMITATIONS AND EASEMENTS.
4. ALL SPECIFICATIONS ARE BASED ON THE CURRENT CHARLOTTE LAND DEVELOPMENT STANDARDS MANUAL (CLDSM).

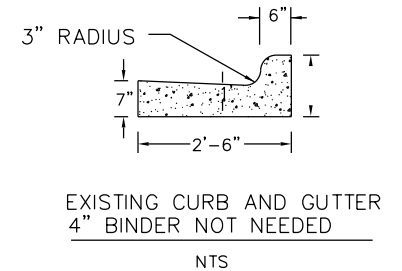
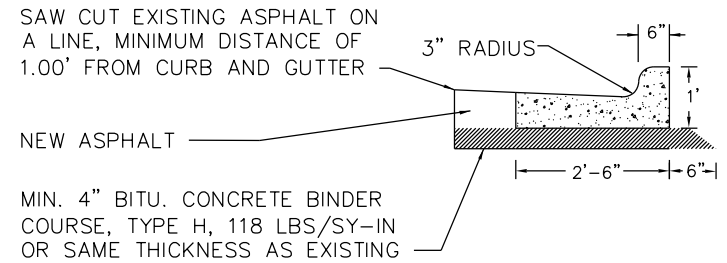
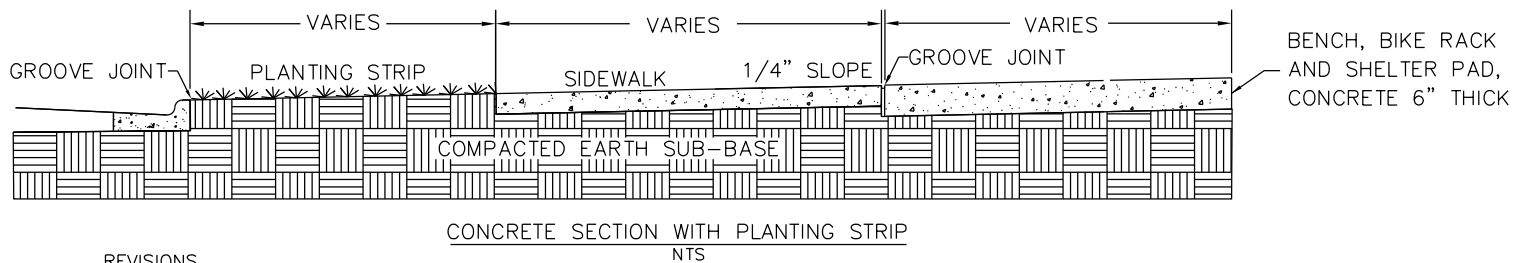
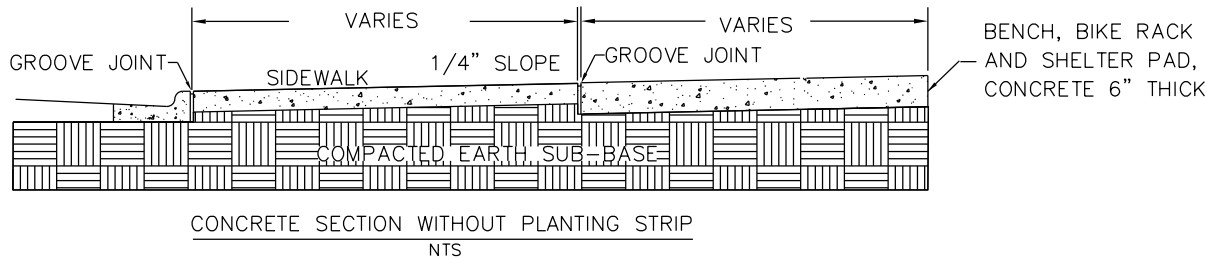

REVISIONS

NO.	DATE	DESCRIPTION

APPROVED DATE _____



CONCRETE DETAILS

STD. NO.	REV.
60.07A	

GENERAL NOTES

1 ACCESS ROUTE FROM SIDEWALKS TO THE BUS STOP

SIDEWALKS WIDTH LEADING TO THE BUS STOP VARY DEPENDING UPON SITE LIMITATIONS AND RIGHT OF WAYS OR EASEMENTS. SIDEWALKS SHALL BE DESIGNED TO MEET THE FOLLOWING: DEPARTMENT OF TRANSPORTATION ADA STANDARDS FOR TRANSPORTATION FACILITIES DATED NOVEMBER 29, 2006 (DOT) SECTION 402, THE NORTH CAROLINA STATE BUILDING CODE, AND THE CHARLOTTE LAND DEVELOPMENT STANDARDS MANUAL (CLDSM).

2 BOARDING AND ALIGHTING AREA

THE BOARDING AND ALIGHTING AREA SHALL HAVE A CLEAR LENGTH OF 96" MINIMUM MEASURED PERPENDICULAR TO THE CURB OR VEHICLE ROADWAY EDGE AND A CLEAR WIDTH OF 60" MINIMUM MEASURED PARALLEL TO THE CURB OR VEHICLE ROADWAY. PERPENDICULAR TO THE CURB OR VEHICLE ROADWAY THE SLOPE SHALL BE 1.5% AND NOT BE STEEPER THAN 1:48. PARALLEL TO THE CURB OR VEHICLE ROADWAY SLOPE SHALL BE THE SAME AS THE ROADWAY, TO THE MAXIMUM EXTENT POSSIBLE. WITHIN THE BOARDING AND ALIGHTING AREA IS THE BUS ACCESS PAD. THIS BUS PAD IS A 3' BY 3' AREA TO ACCOMMODATE THE BUS LIFT AT THE FRONT DOOR OF THE BUS. THIS CLEAR SPACE SHALL NOT BE DEFINED ON THE SLAB. THE BUS ACCESS PAD RUNS PARALLEL TO THE CURB OR VEHICLE ROADWAY. THE BOARDING AND ALIGHTING AREA SHALL COMPLY WITH ADA STANDARDS FOR TRANSPORTATION FACILITIES DATED NOVEMBER 29, 2006 (DOT) SECTION 810.2.2 AND THE NORTH CAROLINA STATE BUILDING CODE.

3 SUBSTITUTIONS

BIDDERS OR PROPOSERS TO OFFER GOODS OR SERVICES THAT ARE EQUIVALENT OR SUPERIOR TO THOSE MANUFACTURERS NAMED OR AS DESCRIBED IN THE GENERAL NOTES SHALL SUBMIT THE PROPOSED SUBSTITUTION TO THE CATS PROJECT MANAGER. BASED UPON THE PROPOSED SUBSTITUTION PROVIDED DURING THE BIDDING PERIOD, THE PROJECT MANAGER SHALL DETERMINE IF THE PROPOSED SUBSTITUTION IS EQUAL OR SUPERIOR TO THE LISTED MANUFACTURERS. BIDDERS OR PROPOSERS WILL BE NOTIFIED OF THE EQUAL OR SUPERIOR SUBSTITUTION PRIOR TO SUBMITTING THEIR PROPOSALS.

4 BENCH

BENCH SHALL BE A MINIMUM LENGTH OF 4' UNLESS NOTED OTHERWISE. ALL BENCH SURFACES SHALL HAVE A SMOOTH FINISH, EASED, ROUNDED OR CHAMFERED EDGES. BENCH SLATS SHALL BE MADE OF A MINIMUM OF 60% POST CONSUMER RECYCLED MATERIAL WOOD-POLYMER COMPOSITE MATERIAL. "V" SHAPED SEAT-DELINEATORS SHALL BE PROVIDED IN THE SEATING AREA. STANDARD POWDER COATING FINISH. COLOR TO BE A CUSTOM COLOR AS SELECTED BY CATS PM. BENCHES ARE TO BE INSTALLED AND AFFIXED TO THE CONCRETE SLAB IN ACCORDANCE WITH THE MANUFACTURER'S SPECIFICATIONS USING 1/2" X 3 3/4" STAINLESS STEEL ANCHOR BOLTS. ALL FASTENERS SHALL SELF LOCKING OR HIDDEN TO DETER UNWANTED REMOVAL. MANUFACTURERS SUBJECT TO COMPLIANCE WITH REQUIREMENTS, AVAILABLE MANUFACTURERS OFFERING PRODUCTS THAT MAY BE INCORPORATED INTO THE WORK INCLUDING BUT NOT LIMITED TO THE FOLLOWING:

4' BENCH

A. TOLAR MANUFACTURING COMPANY, INC. 52" MESA BENCH WITH 1 CENTER V-BAR. (13023-121) (52" X 14 1/2") (www.tolarmfg.com)

B. BARCO 6' SURFACE MOUNT, CEDAR 101 (KBC13110-CD) (www.barcoproducts.com)

6' BENCH

C. TOLAR MANUFACTURING COMPANY, INC. 72" MESA BENCH WITH 2 CENTER V-BAR. (13023-121) (72" X 14 1/2") (www.tolarmfg.com)

D. BARCO 6' SURFACE MOUNT, CEDAR 101 (KBC13110-CD) (www.barcoproducts.com)

5 BIKE RACK

FREESTANDING BIKE RACK FRAME TO BE 1 1/2" SCHEDULE 40 ALUMINUM PIPE 6061-T6 WITH 3/8" THICK ALUMINUM 6061-T6 PLATES. BIKE RACK FINISH SHALL HAVE A SUPER DURABLE POWDER COAT ENAMEL. COLOR TO BE A CUSTOM COLOR AS SELECTED BY CATS PM. BIKE RACK IS TO BE INSTALLED AND AFFIXED TO THE CONCRETE SLAB IN ACCORDANCE WITH THE MANUFACTURER'S SPECIFICATIONS USING 1/2" X 3 3/4" STAINLESS STEEL ANCHOR BOLTS PER PLATE. ALL SURFACES SHALL BE SMOOTH FINISHED AND FREE FROM BURRS, SHARP EDGES, DENTS AND OTHER IMPERFECTIONS. MANUFACTURERS SUBJECT TO COMPLIANCE WITH REQUIREMENTS, AN AVAILABLE MANUFACTURER OFFERING PRODUCTS THAT MAY BE INCORPORATED INTO THE WORK INCLUDING BUT NOT LIMITED TO THE FOLLOWING:

A. TOLAR MANUFACTURING COMPANY, INC. BIKE RACK STD. (14814) (www.tolarmfg.com)

6 BUS SHELTER AND BENCH

BUS SHELTER SHALL BE DESIGNED TO MEET THE NORTH CAROLINA STATE BUILDING CODE. THE SHELTER DESIGN DRAWINGS SHALL BE SIGNED AND SEALED BY A LICENSED NORTH CAROLINA ENGINEER AND SUBMITTED FOR REVIEW. SHELTER SHALL BE CORROSION, RUST, WEATHER RESISTANT, SELF EXTINGUISHING, VANDAL PROOF, IMPACT AND SCRATCH RESISTANT. ALL WALL PANELS SHALL BE REPLACEABLE AND OF A STANDARD SIZE. PANELS SHALL BE ACCESSIBLE FROM THE SIDEWALK AND THE PASSENGER WAITING AREA. BUS SHELTER SHALL BE INSTALLED AND AFFIXED TO THE CONCRETE SLAB IN ACCORDANCE WITH THE MANUFACTURER'S SPECIFICATIONS USING STAINLESS STEEL OR AN APPROVED FASTENERS. FASTENERS SHALL BE SELF LOCKING OR OF A TYPE THAT CANNOT BE LOOSENED WITH READILY AVAILABLE TOOLS. FASTENERS SHALL BE HIDDEN FROM VIEW WHENEVER POSSIBLE AND SHALL BE FLUSH WITH THE SURFACE CONNECTED. ALL SURFACES SHALL BE SMOOTH FINISHED AND FREE FROM BURRS, SHARP EDGES, DENTS AND (CONTINUE SEE SHEET STD. NO. 60.07B)

APPROVED DATE _____

REVISIONS

NO.	DATE	DESCRIPTION



GENERAL NOTES

STD. NO.	REV.
60.07B	

(CONTINUED NOTE #6)

OTHER IMPERFECTIONS. SHELTER SHALL HAVE A SUPER DURABLE POWDER COAT ENAMEL FINISH, WITH A 4-5 MIL FINAL THICKNESS. COLOR TO BE A CUSTOM COLOR AS SELECTED BY CATS PM. MANUFACTURERS SUBJECT TO COMPLIANCE WITH REQUIREMENTS, AVAILABLE MANUFACTURERS OFFERING PRODUCTS THAT MAY BE INCORPORATED INTO THE WORK INCLUDING BUT NOT LIMITED TO THE FOLLOWING:

- A. TOLAR MANUFACTURING COMPANY, INC., SHELTER 10' SERIES (26113-00) (www.tolarmfg.com) .
 - 1) TOLAR MANUFACTURING COMPANY, INC., 72" MESA BENCH (13023-121). BENCH PROVIDED WITHIN THE SHELTER.

7 CONCRETE

READY MIXED CONCRETE STRENGTH SHALL HAVE A MINIMUM COMPRESSIVE STRENGTH OF 3,600 PSI AT 28 DAYS. UNLESS NOTED OTHERWISE CONCRETE SHALL BE INSTALLED IN ACCORDANCE WITH CHARLOTTE LAND DEVELOPMENT STANDARDS MANUAL (CLDSM). BOARDING AND ALIGHTING AREA SHALL HAVE A CONCRETE DEPTH OF 4". TYPICAL SIDEWALK DEPTH IS 4". CONCRETE DEPTH AT BENCHES AND SHELTERS IS 6". A GROOVED JOINT OF 1" DEEP WITH A 1/4" RADIUS SHALL BE REQUIRED IN THE CONCRETE AT 5' INTERVALS. ONE 1/2" EXPANSION JOINT WILL BE REQUIRED WHERE THE SIDEWALL ABUTS ANY STRUCTURE.

8 DETECTABLE WARNINGS

DETECTABLE WARNING ON CURB RAMPS SHALL COMPLY WITH ADA STANDARDS FOR TRANSPORTATION FACILITIES (DOT) SECTION 406.8, THE NORTH CAROLINA STATE BUILDING CODE, AND THE CHARLOTTE LAND DEVELOPMENT STANDARDS MANUAL (CLDSM) STD NO. 10.35B.

9 SIGNS

BUS STOP SIGNS, BUS ROUTE SIGNS AND POST SHALL BE PROVIDED AND INSTALLED BY CHARLOTTE AREA TRANSIT SYSTEM (CATS).

10 TRASH RECEPTACLES

THE EXTERIOR OF THE 32 GALLON TRASH RECEPTACLE TO BE 3/4" #9 EXPANDED METAL WITH 11 GAUGE X 1 1/2" STRIP BORDER AT THE TOP AND BOTTOM OF THE EXPANDED METAL AND VERTICAL SEAM. BOTTOM PLATE TO BE MINIMUM 11 GAUGE STEEL SHEET LASER CUT. ALL WELDING OF RECEPTOR TO BE MIG WELDS. THE LID TO HAVE A ROUND TOP FABRICATED FROM HEAVY DUTY STRUCTURAL PLASTIC WITH A SELF-CLOSING DOOR. THE POLYETHYLENE COPOLYMER-BASED THERMOPLASTIC COATED ELEMENTS SHALL HAVE A 5 YEAR WARRANTY. COLOR TO BE A CUSTOM COLOR AS SELECTED BY CATS PM. TRASH RECEPTACLES ARE TO BE INSTALLED AND AFFIXED TO THE CONCRETE SLAB IN ACCORDANCE WITH THE MANUFACTURER'S SURFACE MOUNT SPECIFICATIONS. MANUFACTURERS SUBJECT TO COMPLIANCE WITH REQUIREMENTS, AVAILABLE MANUFACTURERS

(CONTINUED NOTE #10)

OFFERING PRODUCTS THAT MAY BE INCORPORATED INTO THE WORK INCLUDING BUT NOT LIMITED TO THE FOLLOWING:

- A. ULTRASITE, INC., Model # EX-32 (www.ultra-site.com).
 - 1) LINER: PL-32, HEAVY DUTY PLASTIC
 - 2) LID MODEL: RT-32, ROUND TOP
 - 3) SURFACE MOUNT: SM KIT

11 GROUND SPACE

THIS IS A CLEAR FLOOR OR GROUND SPACE (48" x 30" MINIMUM AREA) LOCATED IN THE BUS SHELTER TO BE USED BY A PASSENGER IN A WHEELCHAIR WAITING FOR THE ARRIVAL OF A BUS. THE GROUND SPACE SHALL BE CONNECTED TO A BOARDING AND ALIGHTING AREA PERPENDICULAR TO THE CURB OR VEHICLE ROADWAY. THE SLOPE SHALL BE 1.5% AND NOT BE STEEPER THAN 1:48. PARALLEL TO THE CURB OR VEHICLE ROADWAY SLOPE SHALL BE THE SAME AS THE ROADWAY, TO THE MAXIMUM EXTENT POSSIBLE.

12 LANDSCAPING

WHEN LANDSCAPING IS BEING PROVIDED SHRUBS SHALL NOT EXCEED 2'-6" IN HEIGHT. SHRUBS THAT REQUIRE PRUNING TO MAINTAIN MAXIMUM HEIGHT ARE NOT RECOMMENDED. SHRUBS SHALL NOT BE PLACED ADJACENT TO THE BACK OF THE SHELTER. ORNAMENTAL OR SHADE TREES ARE RECOMMENDED TO PROVIDE SHADE FOR PASSENGERS. TREES SHOULD BE PLANTED ON THE SOUTH OR WEST SIDE OF THE BUS STOP. WHENEVER POSSIBLE, TREES SHOULD NOT BLOCK THE PASSENGER VIEW OF APPROACHING BUSES. TREES SHALL BE SELECTED AND INSTALLED IN ACCORDANCE WITH CHARLOTTE LAND DEVELOPMENT STANDARDS MANUAL (CLDSM). PROPOSED TREES SHALL BE SUBMITTED AND APPROVED BY THE CITY ARBORIST.

REVISIONS

NO.	DATE	DESCRIPTION

APPROVED DATE _____



GENERAL NOTES

STD. NO.	REV.
60.07C	